

Application Note 1015

Introduction

Readability is the most important feature of an electronic display system. Moreover, readability must be achieved in ambient lighting conditions ranging from darkness to bright sunlight. One of the major contributions to readability in bright ambients is the contrast between the “on” elements of a display and their background. This contrast is expressed as a combination of luminance contrast and chrominance contrast.

At Avago Technologies, a considerable amount of work has been done to define and understand the parameters that affect the luminance contrast and chrominance contrast of an LED display. We have expanded upon the work done by Jean Pierre Galves and Jean Brun and have determined new ways to calculate and optimize the values of the most relevant measure of a display’s readability in bright ambients, the “discrimination index”.^[1]

One of the most readily available techniques to improve the “discrimination index” of a display is to use a carefully selected optical filter in front of the display.

The first section of this application note will discuss contrast enhancement techniques for indoor ambients where all Avago Technologies LED displays can be used. The second section will discuss specific Avago Technologies LED displays and contrast enhancement techniques for the difficult task of achieving good readability in bright sunlight ambients.

Section 1: Filtering for Indoor Ambient Applications

In dim to moderately bright indoor ambients, readability can be obtained by optimizing luminance contrast. The objective is to maximize the luminance contrast between the light emitting elements and the background while minimizing the luminance contrast between the non-illuminated elements and the background. For LED displays, this can be achieved by:

1. Designing the display package for low reflectance so that the luminance of the non-illuminated elements matches the luminance of the display package.
2. Choosing a filter that transmits a maximum amount of LED light while attenuating the reflected light off the display package.
3. Choosing a filter with low front surface reflectance for a given ambient lighting condition.

On the other hand, to obtain readability in bright indoor and sunlight ambients, the optimization of chrominance contrast as well as luminance contrast becomes important. Chrominance contrast refers to the color difference between the light emitting elements and the background. The optimization of chrominance contrast is more fully explained in section two while this section concentrates on the optimization of luminance contrast.

First, to obtain a better understanding of filtering, the more commonly used terms in contrast enhancement will be defined. Next, specific filter transmission recommendations for each LED color will be presented. Also, plastic versus glass filter materials and the effects of ambient lighting on luminance contrast will be discussed. Finally, recommended filter manufacturers and the materials they offer will be listed.

Definitions

Eye Response — Standard Observer Curve

The Standard Observer Curve is important in contrast enhancement because the eye's sensitivity to light emitting sources, ambient lighting and display backgrounds is very dependent on the wavelengths of emitted or reflected visible light. The eye response of a standard observer to various wavelengths of light is shown in Figure 1. The Standard Observer Curve was established in 1931 by the CIE (Commission Internationale De L'Eclairage) as the industry standard for relating the total power (radiant flux) emitted from a source to the amount of power to which the eye is sensitive (luminous flux). The curve is on a logarithmic scale and for reference various wavelengths of energy are labeled by color. As can be seen, the eye's response peaks in the yellow-green region, which means that per watt of radiated power a source in this region will have more lumens than sources of other wavelengths. The exact conversion factor at the peak (555 nm) is 680 lumens of luminous flux (lm) per watt of radiated power (W).

Peak Wavelength and Filter Transmission

The wavelength at the peak of the LED radiated spectrum is called peak wavelength (λ_p). Figure 2 and Table 1 show the typical LED radiated spectrum for four standard colors; red ($\lambda_p = 655$ nm), high efficiency red ($\lambda_p = 635$ nm), yellow ($\lambda_p = 583$ nm) and green ($\lambda_p = 569$ nm). All four standard colors fall in the region of visible light. The appropriate filter for use with any of these four colors is chosen according to its published transmission curve.

Filter transmission curves exhibit relative transmittance vs. wavelength over the region of visible wavelengths. The relative transmittance of a filter with respect to any particular wavelength is defined as:

Relative Transmittance $T(\lambda) =$

$$\frac{\text{Luminous Flux with Filter at Wavelength } \lambda_p}{\text{Luminous Flux without Filter at Wavelength } \lambda_p}$$

If a particular optical filter has a fairly constant transmission over the LED radiated spectrum, then the transmission at the peak wavelength may be used to estimate the amount of display emitted light that passes through the filter. For example, if a filter has a relatively flat transmittance of 60% at a given λ_p , then approximately 60% of the display emitted light will pass through the filter to the observer and 40% will be absorbed. In actuality, the display emitted light passing through a filter (L) is an integral that is the product of several functions. As defined by the following equation, the Standard Observer Curve and LED Spectrum must be integrated with the filter transmission curve.

$$L = \int I(\lambda) Y(\lambda) T(\lambda) d\lambda \quad (1)$$

Where $I(\lambda)$ = radiated spectrum of the illuminated light emitting element (See Table 1)

$Y(\lambda)$ = the 1931 CIE photopic curve (See Wyzecki & Stiles, *Color Science*)

$T(\lambda)$ = relative transmission characteristic of the filter (Supplied by filter manufacturer)

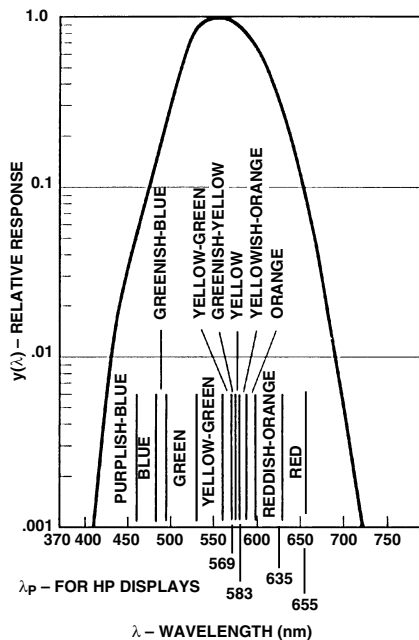

Figure 1. CIE Standard Observer Eye Response Curve (Photopic Curve), including CIE Vivid Color Ranges.

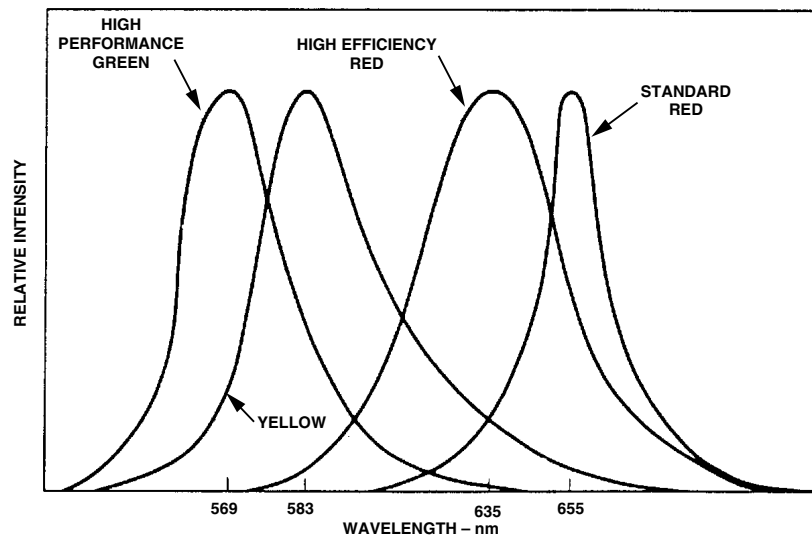

Figure 2. Relative Intensity vs. Wavelength.

Table 1. LED Spectrums Normalized To One At Typical Peak Wavelengths

Wavelength (nm)	Standard Red	High Efficiency Red	Yellow	Green
540	.01	.03		
545	.02	.05		
550	.03	.13		
555	.05	.33		
560	.12	.65		
565	.24	.87		
570	.47	1.00		
575	.73	.85		
580	.92	.67		
585	1.00	.55		
590	.01	.94	.42	
595	.03	.78	.33	
600	.04	.62	.26	
605	.01	.12	.48	.18
610	.01	.20	.37	.14
615	.03	.40	.28	.11
620	.05	.61	.17	.08
625	.13	.78	.13	.07
630	.20	.96	.11	.05
635	.37	1.00	.08	.04
640	.55	.91	.07	.03
645	.75	.81	.06	.03
650	.94	.71	.05	.02
655	1.00	.58	.05	.02
660	.96	.45	.04	.01
665	.84	.36	.04	.01
670	.72	.27	.03	
675	.60	.21	.01	
680	.47	.15		
685	.36	.12		
690	.25	.09		
695	.21	.05		
700	.16	.01		

As shown in Figure 3, if the slope of the filter transmission curve changes rapidly in the region of the LED radiated spectrum, then the transmission at the peak wavelength will no longer be an accurate estimate of display emitted light that passes through the filter. On the other hand, for a more constant transmission, as also shown in Figure 3, the estimate is fairly accurate.

Filter Characteristics Which Determine Light Transmission

As mentioned in *Peak Wavelength and Filter Transmission*, filters are chosen according to their published transmission curves which exhibit relative transmittance vs. wavelength over the region of visible light.

For any filter, the total transmitted light is equal to the LED emitted light less the light absorbed within the filter and the light reflected at the filter-to-air interfaces.

The relative absorption characteristics are determined by the dye color and dye concentration while the reflectance characteristics are determined by the index of refraction of the filter material. Since the index of refraction is nearly a constant, dye coloring and dye concentration are varied to obtain the appropriate transmission at any given wavelength.

When choosing a filter or molding your own material, it is important that the dye color and dye concentration are carefully controlled so that the internal transmission characteristics are consistent from one filter to another. Internal transmittance can be considered the LED emitted light minus the light absorbed within the filter material. Thus, the formula for the LED light transmitted through the filter becomes:

Luminous flux with filter at wavelength $\lambda\rho =$

Luminous flux internally transmitted through the filter – Luminous flux reflected at filter-to-air interfaces

$$T(\lambda) = Ti(\lambda) - R(\lambda) \quad (2)$$

If the dye coloring is held at a constant density, the internal transmission through the filter material at any given wavelength $Ti(\lambda,\rho)$, is an exponential function of the thickness of the material:

$$R = \left(\frac{n_1 - n_2}{n_1 + n_2} \right)^2 \quad (4)$$

$$(Internal Transmission) Ti = e^{-ax} \quad (3)$$

where: x = The quantity of unit thicknesses of filter material .

e = 2.71828

a = Absorption coefficient and is equal to $-\ln(t)$ where t is the internal transmission for a unit thickness.

As shown in Figure 4, the internal transmission through 1.0 mm thickness of filter material is 0.875 at a wavelength of 655 nm. The same filter material at a thickness of 2.5 mm has a relative transmission of 0.716.

$$-\ln(0.875) = 0.1335 = a$$

$$T = e^{-(.1335)(2.5)} = 0.716$$

Light that is not internally transmitted through the filter or absorbed within the filter material is reflected at the filter-air interfaces. The amount of reflected light is dependent upon the index of refraction of the filter material as compared to the index of refraction for air. Mathematically, the percentage of reflected light is given by the following ratio:

where:

n_1 = Index of refraction of the filter material.

n_2 = Index of refraction for air = 1.0.

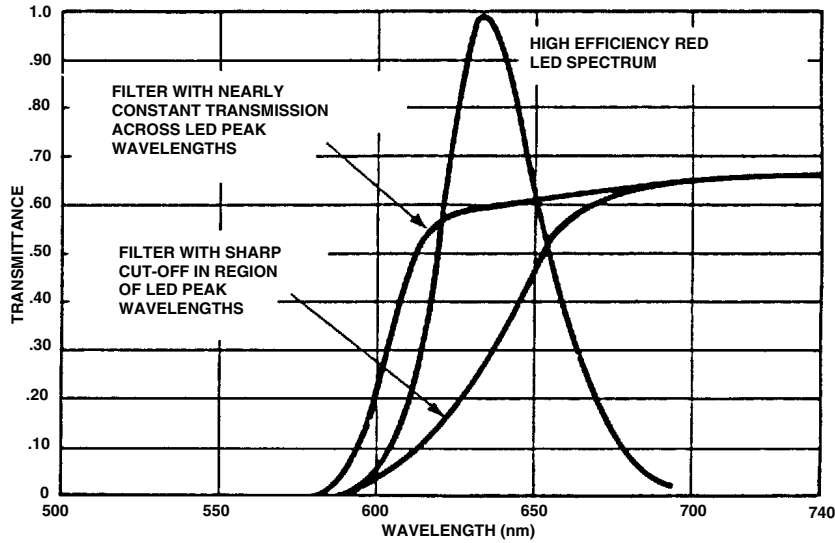

Figure 3. Comparison Between Two Long Pass Red Filters for Use with High-Efficiency Red Displays.

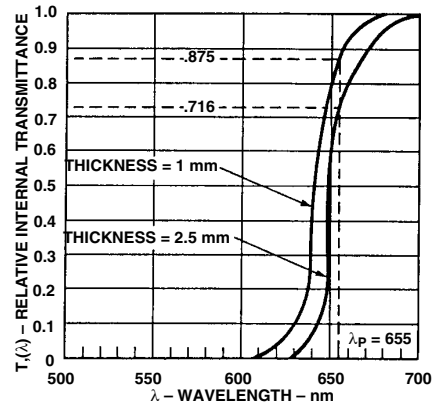

Figure 4. Variation in Relative Transmittance vs. Thickness for a Constant Density Filter Material.

It is important to choose a filter with a homogeneous index of refraction. As shown below, a plastic filter with an average index of refraction equal to 1.5, for the range of wavelengths encompassing the LED's radiated spectrum will reflect 4% of the normal incident light at each filter/air interface.

$$R = \left(\frac{1.5 - 1.0}{1.5 + 1.0} \right)^2$$

$$R = 0.04$$

Since there are two filter-air interfaces, the percentage of LED light lost due to reflection for a filter with an internal transmittance of 0.875 is 7%. Therefore, the total transmittance through the filter according to equation (2) is 0.805 (0.875 - 0.07 = 0.805).

$$\begin{aligned} \text{LED emitted light lost due to reflection} &= \\ &= \text{loss at 1st interface} + \text{loss at 2nd interface} \\ &= 0.04 + (0.96)(0.875)(0.04) \\ &= 0.04 + 0.03 \\ &= 0.07 \end{aligned}$$

In addition to attenuating a portion of the light emitted by the display, a filter also shifts the perceived color of the LED. For a given LED spectrum, the color shift depends on the cut-off wavelength and shape of the filter transmittance curve. A choice among available filters must be made on the basis of which filter and LED combination is most pleasing to the eye.

Luminance Contrast

Conceptually, the luminance contrast is the observed brightness of the illuminated element compared to the brightness of the surround. The brightness of the illuminated element is the combination of the emitted light and the ambient light reflected off the element, while the brightness of the background is due only to reflected ambient light.

Display Luminance Contrast

For a display without a filter, the luminance contrast ratio can be considered the sterance (intensity/unit area) of the illuminated element plus the ambient light reflected off the element divided by the sterance of the ambient light reflected off the background.

$$\text{Luminance Contrast Ratio CR} = \frac{L_V S + L_V \text{OFF}}{L_V B} \quad (5)$$

Where $L_V S$ = Sterance of illuminated element

$L_V \text{OFF}$ = Sterance of light reflected off the element

$L_V B$ = Sterance of light reflected off the background

Mathematically:

$$L_V S = \int I(\lambda) Y(\lambda) d\lambda$$

$$L_V \text{OFF} = \int X(\lambda) Y(\lambda) R_f(\lambda) d\lambda$$

$$L_V B = \int X(\lambda) Y(\lambda) R_b(\lambda) d\lambda$$

where

$I(\lambda)$ = radiated spectrum of the illuminated light emitting element (See Table 1)

$Y(\lambda)$ = the 1931 CIE photopic curve (See Wyzecki & Stiles, *Color Science*)

$X(\lambda)$ = radiated spectrum of the ambient light source (See Wyzecki & Stiles, *Color Science*)

$R_f(\lambda)$ = relative reflection characteristic of the light emitting element (See Figures 24 and 35)

$R_b(\lambda)$ = relative reflection characteristic of the surrounding background (See Figures 24 and 35)

When designing a display for optimum luminance contrast, two conditions must be considered. First, it is desirable to have as large a contrast ratio as possible between the illuminated elements and the surrounding background ($C_{\text{ON}} = L_V S / L_V B > 1$). This is achieved by choosing a background with low reflectance. Second, it is desirable to minimize the contrast ratio between the non-illuminated light emitting elements and the background, both of which reflect ambient light ($C_{\text{OFF}} = L_V \text{OFF} / L_V B = 1$). This second condition is achieved by choosing a background that nearly matches the reflective characteristics and color of the non-illuminated elements. Thus, the non-illuminated elements will blend into the background in the off condition and in the on condition the eye will not be confused as to which elements are illuminated. For example, Avago stretched segment displays for indoor applications are designed such that the painted surrounding package matches the reflected luminance and color of the tinted epoxy segments. Another type of stretched segment display has been designed for high ambient applications. This display package is painted gray to match the luminance and color of the untinted segments.

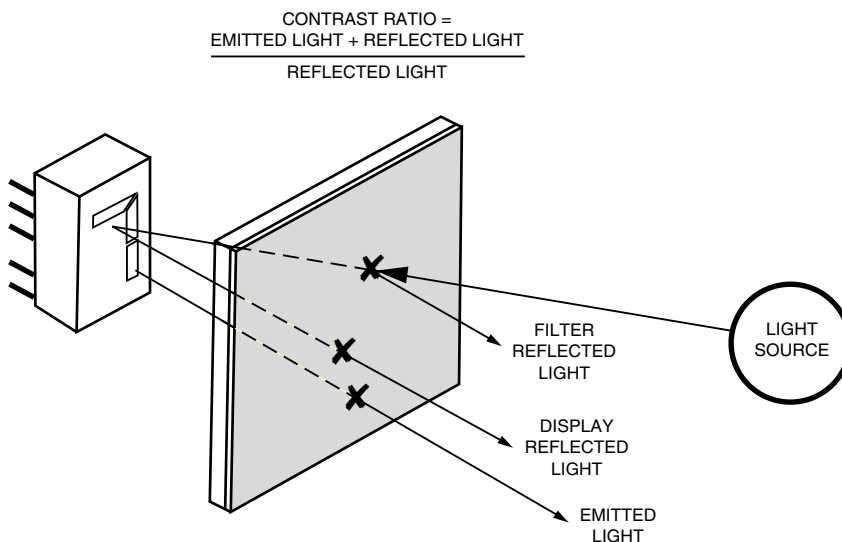

Figure 5. Luminance Contrast for a Light Emitting Display with a Filter.

Enhancement of Luminance Contrast — Filtering

The purpose of filtering is to create a high value of luminance contrast by reducing the luminous sterance of the background to a level that is far less than the luminous sterance of the illuminated segments. Wavelength filters increase contrast by passing the wavelengths of LED emitted light while partially absorbing other wavelengths of ambient light. Neutral density filters increase contrast by attenuating ambient light twice, as it enters the filter and after reflection, whereas the LED emitted light is attenuated only once.

When a filter is placed in front of a display, the luminance contrast equation (5) is altered due to two effects. First, the sterance of the illuminated elements and the background is attenuated by the filter. Second, the eye adds the ambient light reflected off the front surface of the filter to both the illuminated elements and the background. Therefore, as shown in Figure 5, the luminance contrast ratio for a light emitting display with a filter can be expressed as:

$$\text{Luminance Contrast Ratio CR} = \frac{L_v S + L_v \text{OFF} + L_v F}{L_v B + L_v F} \quad (6)$$

Where

$L_v S$ = Sterance of illuminated element through the filter

$L_v \text{OFF}$ = Sterance of light reflected off the element through the filter

$L_v B$ = Sterance of light reflected off the background through the filter

$L_v F$ = Sterance of light reflected off the filter

Mathematically:

$$L_v S = \int I(\lambda)Y(\lambda)T(\lambda) d\lambda$$

$$L_v \text{OFF} = \int X(\lambda)Y(\lambda)T(\lambda)^2 R(\lambda) d\lambda$$

$$L_v B = \int X(\lambda)Y(\lambda)T(\lambda)^2 R_B(\lambda) d\lambda$$

$$L_v F = \int X(\lambda)Y(\lambda)R_F(\lambda) d\lambda$$

where

$I(\lambda)$ = radiated spectrum of the illuminated light emitting element (See Table 1)

$Y(\lambda)$ = the 1931 CIE photopic curve (See Wyzecki & Stiles, *Color Science*)

$T(\lambda)$ = relative transmission characteristic of the filter (Supplied by filter manufacturer)

$X(\lambda)$ = radiated spectrum of the ambient light source (See Wyzecki & Stiles, *Color Science*)

$R(\lambda)$ = relative reflection characteristic of the light emitting element (See Figures 24 and 35)

$R_B(\lambda)$ = relative reflection characteristic of the surrounding background (See Figures 24 and 35)

$R_F(\lambda)$ = relative reflection characteristic of the filter front surface (See Table 5 and Figure 37)

As exhibited by the luminance contrast equation, display readability is greatly affected by the amount and direction of ambient light reflected back into the observer's eyes ($L_v F$). If too much ambient light is reflected back into the observer's eyes, the luminance contrast ratio will approach a value of 1 and the illuminated elements will be masked from view. The reflected ambient light, $L_v F$, is determined by both the filter material and the front surface texture.

For dim to moderate ambients a textured surface may be advantageous to diffusely scatter any specular reflectances from nearby light sources. However, care must be exercised when choosing the amount of front surface texture. It should be remembered that both the incident ambient and display emitted light will be diffused. Therefore, to prevent the display image from appearing too blurred, the filter should be mounted as close as possible to the display. ($d < 1/4"$)

If higher levels of ambient light may be present from a light source or nearby window, the front surface should have only a very slightly textured finish. Due to the larger quantities of incident ambient light, too coarse a texture will create a large amount of scattered diffuse glare and obscure view of the display. As explained later in *Front Surface Reflectance and Filters for Contrast Enhancement — Seven Segment LED Displays*, the other option in higher ambient light levels is to use an untextured surface and cant the filter slightly forward such that specular reflectances are directed downward, away from the eyes of the observer.

Typical Lighting Levels

The level and spectrum of ambient lighting affects the luminance contrast of any display and filter assembly. According to the IES lighting handbook, the following illumination standards are typical for tasks performed indoors; 25-75 foot-candles for passageways and active storage rooms, 75-200 foot-candles for desk work and up to 1000 foot-candles for extra fine bench or machine work.^[2] In this application note, 25-75 foot-candles ambient illumination will be referred to as dim ambients, 75-200 foot-candles as moderate ambients and 250-1000 foot-candles as bright ambients. Illumination levels can be easily measured with a calibrated color corrected light meter. Some commercially available light meters are the *Gossen Panlux Electronic Luxmeter*, the *Spectra Lumicon* and the *Sekonic L398*. For indoor applications, the spectrum of ambient lighting can vary from fluorescent to incandescent or even sunlight from a nearby window.

Recommendations for Wavelength Filtering

Figure 2 shows the radiated spectrum for a typical standard red, high efficiency red, yellow and green LED and Figures 6 through 10 along with Table 2 summarize the recommended filter transmission curves for each of these colors. Filters with similar characteristics are commercially available and specific manufacturers are listed in Tables 3 and 4. For all colors there are three recommended curves: one for dim ambients, another for moderate ambients and finally a third curve for bright ambients. The curves for moderate and bright ambients have a lower transmission to further reduce the greater amount of reflected ambient light off the display background. In the following section the reasons for specifying a particular transmission curve for each LED color are explained.

Filtering Standard Red Displays ($\lambda_p = 655 \text{ nm}$)

In dim to moderate ambients, filtering out reflected ambient light from red displays is easily accomplished with a long wavelength pass filter having a sharp cut-off in the 600 nm to 630 nm range (see Figure 6). This long wavelength pass filter absorbs the shorter yellow, green and blue wavelengths while passing the red wavelengths and those longer wavelengths to which the eye is not very sensitive. In brighter ambients, above 200 foot-candles a gray filter with 18-25% transmission is recommended (See Figure 10). As explained later in *Filtering in Bright Sunlight Ambients*, the gray filter increases readability in brighter ambients by enhancing the color contrast between the illuminated elements and the background.

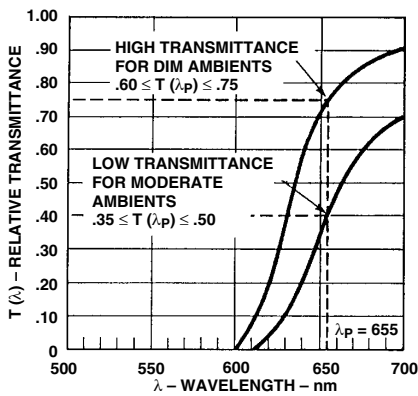

Figure 6. Typical Transmittance Curves for Filters to be used with Standard Red Displays.

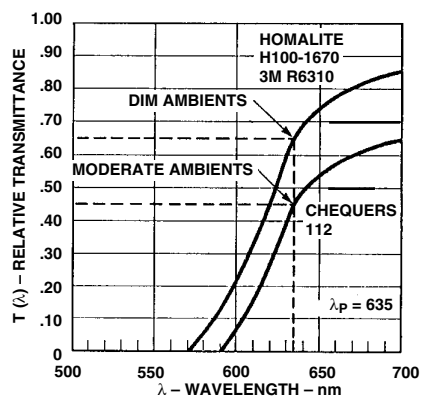

Figure 7. Typical Transmittance Curves for Filters to be used with High Efficiency Red Displays.

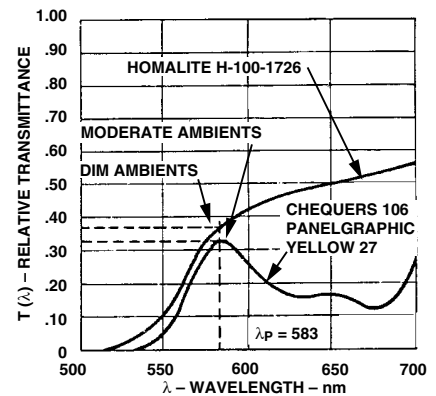

Figure 8. Typical Transmittance Curves for Filters to be used with Yellow Displays.

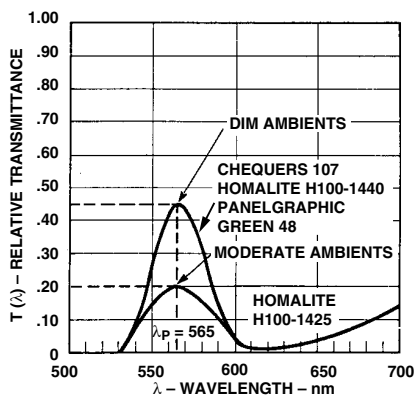

Figure 9. Typical Transmittance Curves for Filters to be used with Green Displays.

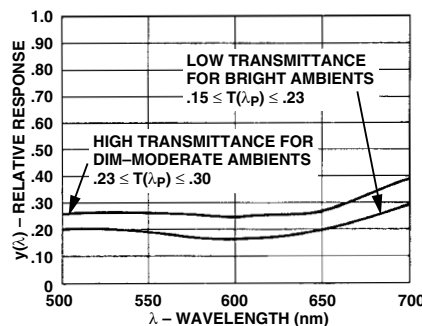

Figure 10. Typical Transmittance Curves for Filters to be used with All Colored Displays.

Filtering High Efficiency Red Displays ($\lambda_p = 635 \text{ nm}$)

In dim to moderate ambients, the use of a long wavelength pass filter with a cut-off in the 570 to 600 nm gives essentially the same results as obtained when filtering red displays (see Figure 7). The resulting color is a deep reddish orange. If several displays are to be assembled in a line, the particular red filter should be chosen carefully. Many red filters have a sharp cut off in the 610-640 nm range, which falls in the same region as the peak wavelengths of high efficiency red LEDs. As explained in *Peak Wavelength and Filter Transmission* this sharp cut-off may cause an LED with a peak wavelength of 640 nm to pass much more LED emitted light through the filter when compared to an LED with a peak wavelength of 630 nm. If the cut-off is too sharp, the eye may perceive intensity mismatches between these light emitting elements. Two possible filtering techniques can be employed to minimize intensity variations. First, a red filter can be used which exhibits 35-50% transmission and a relatively flat transmission curve in the 620-640 nm wavelength range (see Figure 7). Or, second, a gray filter that has a constant 18-25% transmission across the visible spectrum can be used (see Figure 10). Gray filters with 18-25% transmission are also recommended for bright ambients above 200 foot-candles. As explained later in *Filtering in Bright Sunlight Ambients* the gray filter increases readability in brighter ambients by enhancing the color contrast between the illuminated elements and the background.

Filtering Yellow Displays ($\lambda_p = 583 \text{ nm}$)

In dim ambients, amber filters or yellow band pass filters are recommended for filtering yellow displays (see Figure 8). It is more difficult to achieve a high contrast when filtering yellow displays because yellow is in the region of the standard observer curve where the eye is most sensitive. In this case, both the yellow LED emitted light and the yellow ambient light reflected off the display back-

ground will be passed by the filter. In order to achieve a noticeable contrast between the LED emitted light and the background reflected light, the filter must absorb a greater amount of ambient light than a red filter.

The most effective filters are dark yellow or orange (amber), although a lower transmittance yellow band pass filter may be used. Figure 11 shows the effect of such a yellow band pass filter on a yellow LED display with a peak wavelength of 583 nm. Although only 27% of the display emitted light passes through the filter, the contrast is enhanced. For moderate ambients an amber filter or a gray filter with 20-25% transmission is recommended. And as recommended for red displays in brighter ambients above 200 foot-candles a gray filter with 18-23% transmission should be used.

Filtering Green Displays ($\lambda_p = 565 \text{ nm}$)

Since the peak wavelength of a green display is typically only 10 nm away from the peak of the standard observer curve, it is difficult to achieve high contrast through filtering. A long wavelength pass filter, such as is used for red and yellow displays, is no longer effective. An effective filter for dim ambients is a band pass yellow-green filter which peaks in the region of the LED spectrum. Similar to yellow band pass filters, the recommended green band pass filter reduces background reflected light (see Figure 9) by having a much lower transmission than a red filter. Figure 12 shows the effect of a green band pass filter on a green LED with a peak wavelength of 565 nm. Although only 33% of LED emitted light passes through the filter, the contrast is enhanced. Due to the increased sensitivity of the eye to background reflected light, a gray filter with 20-25% transmission is recommended for moderate ambients and a lower transmission gray filter of 18-20% for brighter ambients.

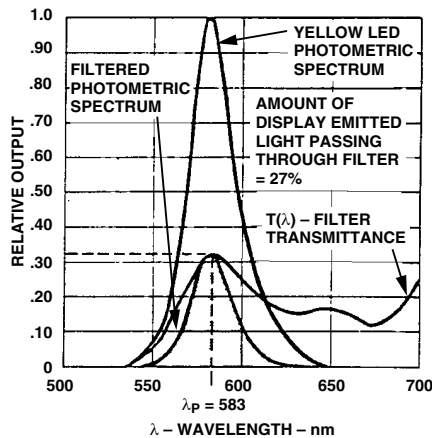

Figure 11. Effect of a Wavelength Filter on a Yellow LED Display.

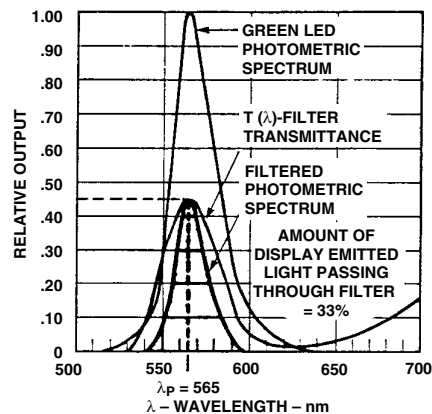

Figure 12. Effect of a Bandpass Wavelength Filter on a Green LED Display.

Table 2. Filter Recommendations for Various Display Colors and Levels of Ambient Illumination.

Color	Ambient Illumination	Recommended Filter Type	Comments
Standard Red (λ_p Typical = 655 nm)	Dim (25-75 fc)	Red Long Pass (70%T) with cut-off in 600-630 nm region	Red Filters will save power because a maximum amount of LED light is
	Moderate (75-200 fc)	transmitted through the filter Red Long Pass (45% T) Neutral Density Gray or Bronze (20-25% T)	
	Bright (200-1000 fc)	(none)	(not recommended)
High Efficiency Red (λ_p Typical = 635 nm)	Dim	Red Long Pass (65% T) with cut-off in 570-600 nm region	Red Filters will save power because a maximum amount of LED light is transmitted through the filter
	Moderate	Red Long Pass (40% T) Neutral Density Gray or Bronze (20-25% T)	Red Filters with sharp cut-off in the 610-640 nm range may cause intensity mismatches
	Bright	Neutral Density Gray or Bronze (18-23% T)	Gray or Bronze filters enhance color contrast
Yellow (λ_p Typical = 583 nm)	Dim	Yellow Band Pass (30% T) Amber Long Pass (40% T)	Most effective filter is amber although a yellow band pass filter may be used
	Moderate	Amber Long Pass (40% T)	
	Bright	Neutral Density Gray or Bronze (18-23% T) Neutral Density Gray (30% T)/ Light Amber (80% T) combination	Gray, Bronze, or Gray/Amber combination filters enhance color contrast
Green (λ_p Typical = 569 nm)	Dim	Green Band Pass (45% T)	
	Moderate	Neutral Density Gray or Bronze (20-25% T)	Gray recommended for moderate-bright ambients because the eye is very sensitive to background reflected light in the green region
	Bright	Neutral Density Gray or Bronze (18-23% T)	Gray or Bronze filters enhance color contrast

Filtering All Display Colors

If displays of different colors are to be placed behind one filter, a neutral density gray filter is the best choice. Neutral density gray filters have nearly constant transmission across the visible spectrum. They enhance contrast by attenuating ambient light twice, both as it enters the filter and after reflection, whereas the LED emitted light is attenuated only once. To maximize the contrast between off elements and the background, 18-25% transmission is recommended (see Figure 10). To minimize the contrast between off elements and the background, a gray bodied display should be used, although colored bodied displays can also be used behind a gray filter. Also, as mentioned in filtering high efficiency red displays, neutral density gray filters with nearly constant transmission offer the

advantage of minimizing intensity variations between displays.

In addition, neutral density gray filters with 18-25% transmission are recommended for bright indoor ambients above 200 foot-candles and for sunlight ambients. As explained later in Section 2 the gray filter increases readability in bright ambients by enhancing the color contrast between the illuminated elements and the background. The exact transmission is dependent upon the filter front surface reflectance and the level of ambient lighting. In moderate to bright ambients a filter with fairly low diffuse reflectance and 20-25% transmission is recommended. For brighter ambients, above 1000 foot-candles, a filter with lower diffuse reflectance and 15-20% transmission is recommended.

Table 3. Plastic and Glass Filter Manufacturers

Plastic Filter Manufacturers

Manufacturer	Product
3M Optical Systems Bldg. 223-1N-03, 3M Ctr. St. Paul, MN 55144-1000 USA Tel: 612-733-1100 800-553-9215 Fax: 612-733-2298	Polycarbonate louvered Light Control Film (LCF), four levels of surface gloss available.
Astra Products, Inc. PO Box 0479 Baldwin, NY 11510 USA Tel: 516-223-7500 Fax: 516-868-2371	Clarex® wavelength and neutral density filters; anti-reflection coatings.
Coating Technologies International (formerly Panelgraphic Corp.) 10 Henderson Dr. West Caldwell, NJ 07006 USA Tel: 201-227-1500 Fax: 201-227-7750	Chromafilter® wavelength and neutral density filters; Vueguard® scratch-resistant and anti-reflection coatings; EMI-shielding coatings.
Homalite Brookside Dr. Wilmington, DE 19804 USA Tel: 800-346-7802 Fax: 800-884-8777	Polyester and polycarbonate 11 wavelength and neutral density filters; two optional anti-reflection surfaces and three grades of material available.
Hoya Optics, Inc. 3400 Edison Way Fremont, CA 94538-6190 USA Tel: 510-490-1880 Fax: 510-490-1988	
Polaroid Corporation Polarizer Division One Upland road, N2-1K Norwood, MA 02062 USA Tel: 617-446-4505 800-225-2770 Fax: 617-446-4600	Circular Polarizing filters with an optional anti-glare surface; EMI-shielding filters.

Glass Filter Manufacturers

Manufacturer	Product
Liberty Mirror Div. of Pilkington 851 Third Avenue Brackenridge, PA 15014-1498 USA Tel: 412-224-1800 Fax: 412-224-8754	Optically-coated glass with circular polarizer. Aero-space, Inc.
Optical Coating Laboratory, Inc. (OCLI) 2789 Northpoint Parkway Santa Rosa, CA 95407-7397 USA Tel: 707-545-6440 Fax: 707-525-7410	High-efficiency, anti-reflection (HEA®) coatings for glass filters; optically coated glass filters; Glare-guard® contrast enhancement coating.
Polaroid Corporation Polarizer Division One Upland road, N2-1K Norwood, MA 02062 USA Tel: 617-446-4505 800-225-2770 Fax: 617-446-4600	Optically coated glass with circular polarizer.
Schott Glass Technologies, Inc. 400 York Ave. Duryea, PA 18642 USA Tel: 717-457-7485 Fax: 717-457-6960	Glass wavelength and neutral density filters; NVIS-compatible glass filters.
Schott Glaswerke Optics Division Product Group Optical Filters PO Box 2480 D-55014 Mainz, Germany Tel: 0 61 31 / 66 24 22 Fax: 0 61 31 / 66 20 60	

Table 4. Recommended Products and Applications for Plastic and Glass Filters

Filter Products	% Transmission at LED Peak	LED Display Color	Ambient Lighting	Maximum Front Surface Texture If Desired
PLASTIC FILTER PRODUCTS				
Homalite Grade 100				
H100-1670	71%	High Eff. Red Yellow	Dim-Moderate	LR-72, LR-92
H100-1720	46%		Dim to	LR-72
H100-1726	34%		Moderate	
H100-1440	40%	Green	Dim	LR-72
H100-1436	25%			LR-92
H 100-1265 (Gray)	25%	All	Bright or Sunlight	None
H 100-1250 (Gray)	26%			
Rohm & Haas - Plexiglas®				
2423	65%	Stand. Red	Moderate	
2074 (Gray)	20%	All	Bright or Sunlight	
2370 (Bronze)	15%			
2538 (Gray)	16%			
3M Company - Panel Film® or Light Control Film®				
R6510	70%	Stand. Red	Dim to Moderate	ABM6
P7710 (Purple)	85%			
R6310	67%	High Effic. Red	Dim to Moderate	ABM6
A5910	45%	Yellow	Moderate	ABM6
ND0220 (Gray)	27%	All	Bright or Sunlight	Glos
Coating Technologies Chromafilter®				
Ruby Red 60	70%	Stand.Red	Dim Moderate	Anti-Reflection
Dark Red 63	50%			None
Scarlet Red 65	60%	High Eff. Red	Dim	Anti-Reflection
Yellow 27	30%	Yellow	Dim Moderate	Anti-Reflection
Amber 23	27%			None
Green 48	48%	Green	Dim	Anti-Reflection
Gray 15	17%	All	Bright or Sunlight	None
Gray 10	23%			
Duralith Corporation				
Red	% transmission can be requested	Stand. Red		
Gray		High Effic. Red All		

Table 4. (Continued)

Filter Products	% Transmission at LED Peak	LED Display Color	Ambient Lighting	Maximum Front Surface Texture If Desired
Polaroid Corporation - Polarizing Filters				
HRCF Red	30%	Stand. Red	Moderate	Non-Glare
HACP Amber	37%	Yellow	Moderate	Non-Glare
HACP 15 (Amber/Gray)	13%		Bright or Sunlight	None
<hr/>				
HNCP 37 (Gray)	37%	All	Moderate	Non-Glare
HNCP 10 (Gray)	10%	All	Sunlight	Optically-coated glass
<hr/>				
GLASS FILTER PRODUCTS				
Schott Optical Glass, Inc.				
RG-645	80%	Stand. Red	Moderate	
RG-630	97%		Dim	
<hr/>				
RG-610	95%	High Effic. Red	Dim	
<hr/>				
Hoya Optics, Inc.				
R-62 90%	Stand. Red	Moderate		
RG-60	85%	High Effic. Red	Moderate	
<hr/>				
Polaroid Corporation - Polarizing Filters				
HNCP 10 (Gray)	10%	All	Sunlight	Optically-coated glass
<hr/>				
Liberty Mirror, Precision Glass Laminations				
Polarizing Filters made to customer specification			Optically-coated glass	
<hr/>				
OCLI Laboratories				
HEA® Coatings placed on glass filters				

Special Wavelength Filters and Filters in Combination

A designer is not limited to a single color wavelength or a neutral density filter to achieve the desired contrast and front panel appearance. Some unique wavelength filters and filter combinations have been successfully developed. One is the purple color filter for use with red LED displays, and another is the use of a neutral density filter in combination with a light amber filter to achieve a dark front panel for yellow LED displays.

The Purple Contrast Filter for Red LED Displays: The filters that have been previously discussed provide a high level of contrast between the illuminated display elements and the surrounding background. Another approach achieves the same contrast ratio, but has a background color quite different than the color of the illuminated LEDs. This color contrast is accomplished by using a dark purple filter with standard red LED displays, as shown in Figure 13. Purple is a mixture of red and blue light which is perceived by the eye as a distinct color from red. Psychologically, a purple contrast filter is more pleasing to many people than a red filter. The reason for this may be that when illuminated, the standard red display stands out vividly against the purple background. Since it is the color difference that enhances the contrast, the purple contrast filter is extremely effective in bright ambients.

Filters In Combination: A neutral density gray filter is often used in combination with other filters to provide a dead front appearance as well as increased contrast in bright ambients. A typical example is given in Figure 14. The resulting filter is the product of the relative transmittance of the light amber, TLA(λ), and the relative transmittance of the neutral density gray, TNG(λ).

$$\text{Filter Transmission } (\lambda) = [\text{TLA}(\lambda) \text{ TNG}(\lambda)]$$

Fraction of Available Light Through a Combination Filter =

$$\frac{\int I(\lambda) Y(\lambda) [\text{TLA}(\lambda) \text{ TNG}(\lambda)] d\lambda}{\int I(\lambda) Y(\lambda) d\lambda}$$

The amount of light reaching the eye of a viewer is 24% of the unfiltered LED spectrum.

Where I(λ) = radiated spectrum of the illuminated light emitting element (see Table 1)

Y(λ) = the 1931 CIE standard observer curve (see Wyzecki & Stiles, *Color Science*)

TLA (λ) = relative transmission characteristic of the filter (supplied by filter manufacturer)

$TNG(\lambda)$ = relative transmission characteristic of the filter. (For neutral density gray filters the transmission can be considered a constant across the visible spectrum)

The advantage is a dark gray front panel window with very low luminous sterance (zero transmission below 525 nm) that retains its appearance in bright ambients. The disadvantage is a considerable reduction in the luminous sterance of the display. This is somewhat offset by the distinct color difference between the illuminated yellow segments of the display and the dark gray background.

Another example is a purple or long pass red filter used behind a neutral density gray filter. The recommended transmittance for both of these filter combinations is discussed further in Section 2, *Filter Recommendations for Seven Segment Displays and Filter Recommendations for Dot Matrix Displays*.

The disadvantage of using two filters in combination is the added loss of LED emitted light due to four filter air interfaces rather than two interfaces. As shown in *Filter Transmittance*, a single plastic filter with a homogeneous index of refraction equal to 1.5 will lose 4% of LED emitted light at each interface. To avoid any additional loss the two filters should be laminated together with an epoxy that nearly matches the index of refraction of the filter materials.

Filter Material and Filter Reflectance

Plastic Filters

Due to their low cost, ease in machining to size and resistance to breakage, plastic contrast filters are being used in the majority of display applications. Most manufacturers of plastic filters for use with LED displays provide relative transmission curves similar to those presented in Figures 6 through 10. When selecting a filter, the transmittance curve shape, attenuation at the peak wavelength, wavelength cut off and front surface reflectance should be carefully considered to obtain optimum contrast. As mentioned previously, in dim to moderate ambients, a textured plastic filter can be used. However, in bright ambients an untextured filter with low diffuse reflectance is the best choice.

Table 3 lists some of the filter manufacturers and where to obtain more information. The LED filters produced by these manufacturers are usable with all LED displays and lamps. Table 4 lists specific wavelength and neutral density filters along with recommended applications.

Optical Glass Filters

Optical glass filters are typically designed with constant density, so it is the thickness of the glass that determines the transmission. This is just the opposite of plastic filters which are usually designed such that all material thicknesses have the same transmission.

The primary advantage of an optical glass contrast filter over a plastic filter is its superior performance. This is especially true for red LED filters. Figure 15 illustrates a red optical glass filter for use with high efficiency red LED displays. The relative transmittance is generally higher than that of a comparable plastic filter, and the slope of the relative transmittance curve is usually much steeper and more closely follows the shape of the radiated spectrum of the LED.

The front surface of an uncoated glass filter typically has 4% specular reflectance and negligible diffuse reflectance. If the filter is to be used in a bright ambient, a High Efficiency Antireflection (HEA) coating can be applied to the front surface. As explained in *Example - Dot Matrix LED Display and Filter*, HEA coatings reduce front surface specular reflectances to 0.25% across the visible spectrum.

Some leading manufacturers of optical glass filters are the Schott Optical Glass, Inc. of Duryea, Pennsylvania and Munich, Germany and Hoya Optics of Fremont, California.

A leading producer of High Efficiency Antireflection (HEA) coated glass is OCLI, Optical Coating Laboratories Inc. of Santa Rosa, California. Table 3 lists some of the filter manufacturers and where to obtain more information. Table 4 lists specific wavelength and neutral density filters along with recommended applications.

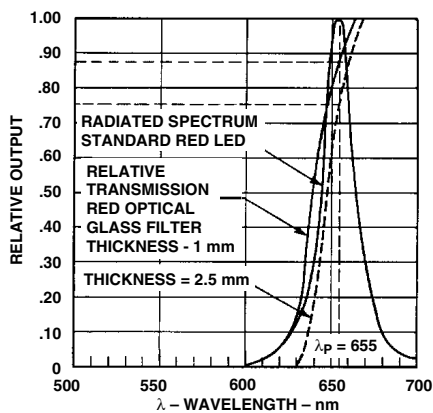

Figure 15. A Red Optical Glass Filter for use with High Efficiency Red LED Displays.

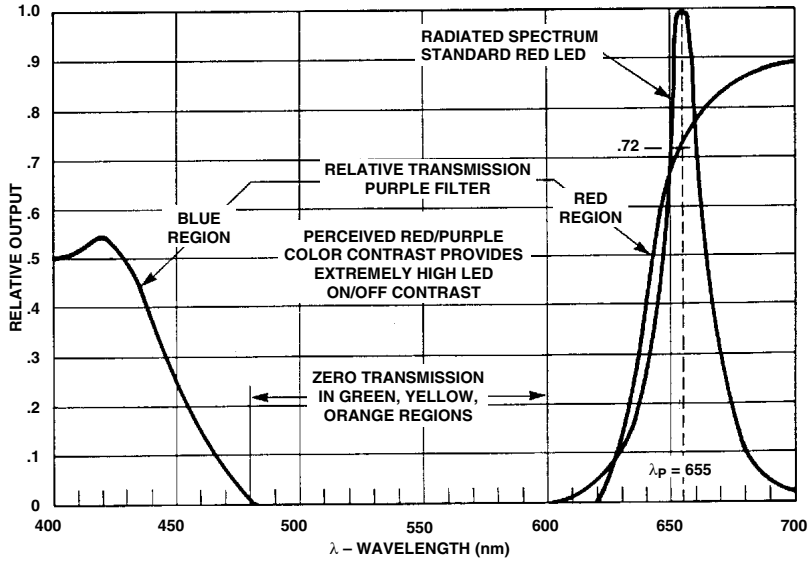

Figure 13. A Purple Color Wavelength Filter for Standard Red LED Displays.

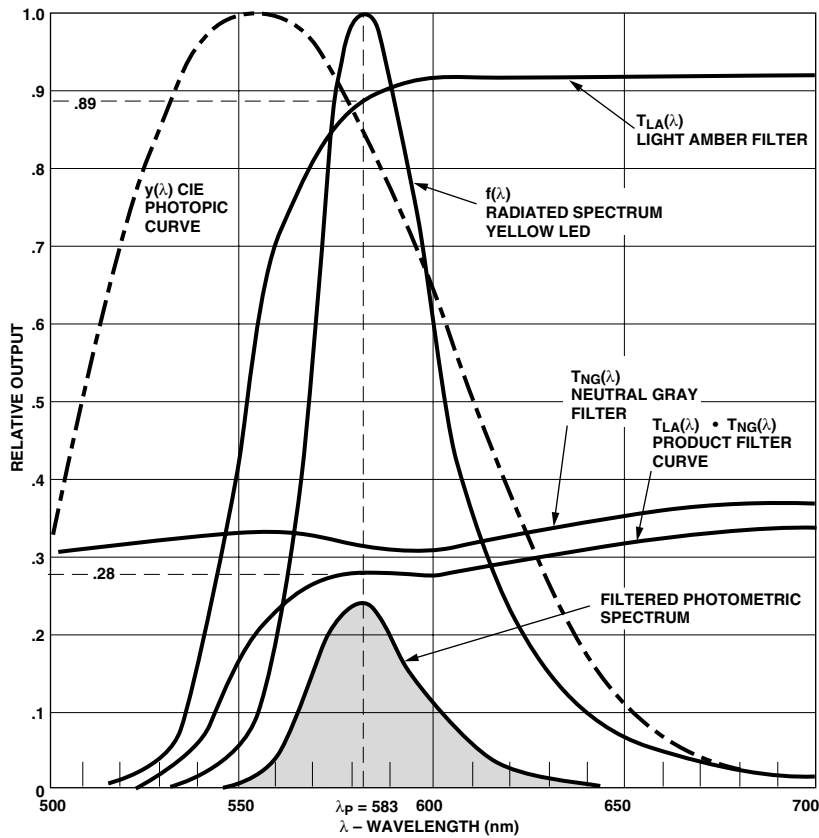

Figure 14. A Neutral Density Gray Filter in Combination with a Light Amber Filter for Use with Yellow Displays.

Effectiveness of a Wavelength Filter in an Ambient of Artificial Lighting

Contrast is very dependent upon the ambient lighting. Figure 16 reproduces the spectral distribution for fluorescent lighting, incandescent lighting, and sunlight.^[3] Fluorescent lighting contains almost no red, yet contains a considerable amount of yellow and long wavelength green. Incandescent lighting is just the opposite. Due to these differences in color content, it is very important to define all lighting spectrums under which the display may be viewed. If a filter is chosen using indoor incandescent lighting, the display may not be readable when used in a sunlight ambient. One frequently encountered example was found in watches and calculators where a high pass red filter was used with a red light emitting display.

If most of the spectral distribution of the artificial lighting is outside of the radiated spectrum of the LED, it is very easy to reduce the reflected ambient light to a very low level without sacrificing too much LED emitted light. Figure 16 also shows the relationship between the peak wavelengths of a red, yellow and green LED and artificial lighting. A red LED can be effectively filtered in a fluorescent ambient because of the lack of red wavelengths in that spectrum. Whereas, in incandescent lighting it is very difficult to reduce the reflected ambient light off a red LED display package. A green LED display can be effectively filtered in an incandescent ambient because of the lack of green wavelengths in that spectrum. Whereas, in fluorescent lighting it is difficult to reduce the reflected ambient light off the display package without significantly decreasing the LED emitted light.

Section 2: Filtering in Bright Sunlight Ambients

In recent years, light emitting diode (LED) displays have been used in an increasing number of avionics, automotive, and other applications where high levels of ambient light are present. LED displays of the latest package design and with the brightest dye and appropriate contrast enhancement filters, are now being used in ambients up to 107,000 lm/m² (10,000 foot-candles). In these bright ambients the following parameters effect the readability of an LED display:

- a) Luminance contrast
- b) Chrominance (color) contrast
- c) Front surface reflections

Historically, when determining sunlight readability, most engineers have considered only the luminance contrast — the ratio of sterance between the illuminated element and its background. Unfortunately, this approach neglects the chrominance contrast of the display – the color difference between the illuminated element and its background. Color must be considered because the eye is sensitive to color differences, as well as differences in luminance. Finally, the luminance and chrominance contrast can be combined into a quantitative measure of sunlight readability, known as the discrimination index. This index was first proposed in 1975 by Jean Pierre Galves and Jean Brun^[4] at the 29th Agard Avionics Panel Technical meeting in Paris, France and later adapted to LED displays in 1977 by Dave Evans.^[5] Discrimination indices determined under similar ambient conditions permit LED displays to be ranked in order of readability.

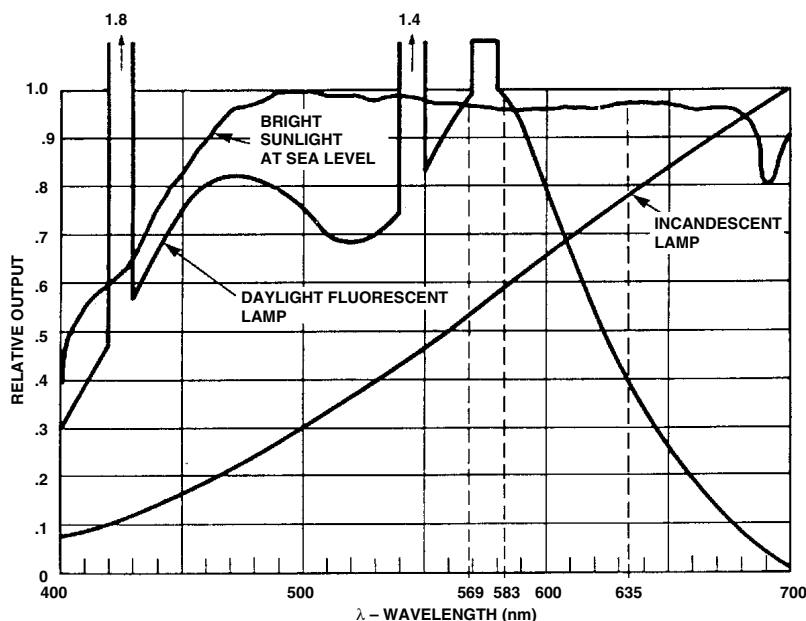

Figure 16. Spectral Distribution for Sunlight, Daylight Fluorescent and Incandescent Ambient Lighting.

The effect of ambient reflected light, briefly mentioned in the Discrimination Index theory is more fully defined in this application note. Specifically examined is how light reflected off the front surface of the filter affects the calculation of luminance contrast and how the color of the emitted light mixed with ambient reflected light affects the chrominance contrast. In order to quantify these effects, the sunlight ambient, the reflectance characteristics of the display and filter surfaces, as well as the observer's viewpoint must be defined.

Sunlight is defined according to its spectrum, intensity and luminous distribution. As shown in Figure 16 the spectrum of bright sunlight is nearly a flat curve across the visible spectrum. The worst case intensity of bright sunlight can range from 5,000 foot-candles falling on an automobile dashboard to 7,000 foot-candles for commercial aircraft with a fixed overhead, up to 10,000 foot-candles for military aircraft. Two worst case sky luminous distributions should be considered: the sun as a single spot source, and a diffuse sunlight ambient. The first condition describes a clear blue sky where the bright glare of the sun's image is reflected back into the observer's view. Because the sterance of the sun's reflected image off of any optical filter is several orders of magnitude greater than the sterance of the illuminated elements, a portion of the illuminated elements will be masked from view. However, it should be remembered that in reality this worst case viewing condition is seldom encountered. Also, with standard mounting techniques the reflected image of the sun can be blocked from the front surface of the filter.

On the other hand, a more commonly encountered worst case viewing condition is a diffuse sunlight ambient that is incident on a filtered display. This condition describes a clear blue sky, ignoring the reflected image of the sun. In the following sections the sky luminous distribution is considered to be a diffuse sunlight ambient.

To understand filtering in bright sunlight ambients according to the Discrimination Index Theory the following topics will be discussed. First, the effectiveness of wavelength filters in diffuse sunlight ambients will be determined. Second, the reflectance of LED display and filter front surfaces will be discussed. Third, the luminance, chrominance and discrimination indices will be defined with special consideration for the effect of ambient reflected light. Fourth, specific filtering techniques will be presented using a seven segment display example and an alphanumeric display example in an ambient of 107,000 lm/m². Finally, as a guide for design engineers, specific recommendations for filtering red, yellow, and green displays will be presented along with a list of plastic and glass filter manufacturers.

Effectiveness of a Wavelength Filter in Sunlight Ambients

Wavelength filters are not recommended for sunlight ambients due to the undesirable effects on luminance and chrominance contrast. Certain high transmission wavelength filters will create insufficient luminance contrast. This occurs when the combination of reflected sterance off the display background, as seen through the filter and off the front surface of the filter, is far greater than the sterance of the light emitting elements.

Also, wavelength filters create little color contrast between the light emitting elements and the background. This is due to the fact that color is determined by the wavelengths of emitted or reflected light. Wavelength filters pass a large amount of reflected background light having the same wavelength as the LED emitted light. Thus, a red display with a red filter in a sunlight ambient will appear to have both red light emitting elements and a red background. Readability will be poor due to the lack of color contrast.

Although wavelength filters are not recommended for sunlight ambients, other filters can be used. Actually, LED displays are quite readable in diffuse sunlight ambients if the package design and filtering techniques optimize both luminance and chrominance contrast. Before defining luminance and chrominance contrast, the effect of front surface reflectance should be considered.

Discrimination Index Theory

Front Surface Reflectance

The Discrimination Index theory can be applied to any display technology. However, it is important to consider the front surface reflectance of the display package and even more importantly the reflectance of the filters which are typically used to enhance contrast. Front surface reflectance will decrease the contrast ratio and also desaturate the color of the display. Color desaturation occurs in bright sunlight when the eye mixes the display emitted light with the reflected ambient light.

The amount of reflected ambient light in a diffuse sunlight ambient is dependent upon the front surface material and also on the viewing condition. As shown in Figure 17 there are two viewing conditions that should be considered. First is a typical viewing condition where the observer sees only diffuse reflectance. Diffuse reflectance refers to scattered light. A highly diffusing surface will appear equally bright from all angles of view because the radiation pattern is nearly lambertian. For a lambertian pattern, the intensity of emitted light varies as the cosine of the off-axis angle. The examples in *LED Seven Segment Display Example and Dot Matrix LED Display Example* assume all devices measured are lambertian. Thus, for diffuse reflectance the total percent reflected light is divided by p to arrive at the sterance (cd/m²).

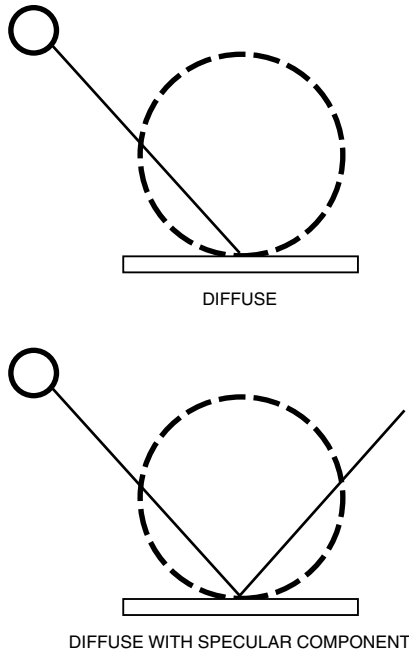

Figure 17. Types of Background Reflections from Display Surfaces — Two Viewing Conditions.

Second, is a worst case viewing condition where the observer sees both diffuse and specular reflectance. Specular reflectance refers to a ray or beam of light that is reflected from a planar surface, such as a mirror, where the angle of reflection equals the angle of incidence. Both angles are measured from a line perpendicular to the surface called the normal. The formulas used to calculate luminance index and chrominance index under conditions of reflected ambient light are derived in the following section. Appendix A shows the integrals used in computation.

Luminance Contrast and Luminance Index^[6]

As previously defined in *Enhancement of Luminance Contrast — Filtering*, the luminance contrast ratio for a filtered LED display is given by the following equation:

Luminance Contrast Ratio $CR = \frac{L_vS + L_vOFF + L_vF}{L_vB + L_vF}$ (7)

Luminance difference, EL, can be defined as the eye’s response to the contrast ratio. Because the eye responds to changes in light levels logarithmically, EL is defined as (Luminance Difference) $EL = \text{Log CR}$ (8)

As established in photography and television, the smallest discernable contrast ratio the eye can perceive is 1.05. This contrast ratio of 1.05 inserted in the luminance difference equation (EL) yields a threshold luminance difference

(ELTH) of 0.021. However, for comfortable discernability it has been demonstrated in photography and television that a contrast ratio of 1.4 between two pieces of monochrome information is desirable. This yields a luminance difference of 0.15, called a unitary luminance difference (ELU) which is seven times the threshold luminance difference (ELTH).

$ELTH = \text{Log } 1.05 = 0.021$ (9)

$ELU = \text{Log } 1.4 = 0.15$

The unitary luminance difference (ELU) can be visually observed by comparing two monochromatic steps on the Kodak gray scale that are four steps apart. On the gray scale each step represents a 10% change in luminance, so two steps, four steps apart, represents a 40% change in luminance.

The ratio of the luminance difference of an actual display compared to the unitary luminance difference (ELU) is called the luminance index (IDL). An IDL value of one would imply a display with a luminance difference just large enough for comfortable discernability. Any value of luminance index greater than or equal to one is desirable.

(Luminance Index) $IDL = \frac{EL}{ELU} = \frac{\text{Log CR}}{0.15}$ (10)

Thus, using the previously defined contrast equation, the luminance index for a filtered LED display becomes:

Luminance Index Filtered LED Display $IDL = \text{Log} \left(\frac{L_vS + L_vOFF + L_vF}{L_vB + L_vF} \right) / 0.15$ (11)

Chrominance Contrast and Chrominance Index^[7]

Chrominance contrast is a normal part of everyday life. For example, an observer can easily distinguish a gold braid on a purple robe. Even so, the concept of chrominance contrast has only recently been applied to light emitting displays in order to achieve readability in bright sunlight. Before defining chrominance contrast and chrominance index, the determination of LED color and the concept of color difference must be explained.

LED Color: High efficiency red, yellow and green devices of the GaP substrate technology are possible colors for use in sunlight ambients. The GaP (gallium phosphide) substrate LED technology is chosen because its quantum efficiency is significantly higher than the GaAs (gallium arsenide) substrate technology.

The 1931 CIE Chromaticity Diagram is used to objectively determine the color of an LED. The CIE system is based on the concept of additive color mixing as derived from experiments in which colors were matched by mixing colored lights. LED color is defined by the dominant wavelength which is that wavelength of the color spectrum which, when additively mixed with the light from the source CIE illuminant C, will be perceived by the eye as the same color as is produced by the radiated spectrum. CIE illuminant C is a 6500-degree Kelvin color temperature source

that produces light which simulates the daylight produced by an overcast sky. A graphical definition of λ_d and color purity is given on the CIE chromaticity diagram in Figure 18. The dominant wavelength is derived by first obtaining the x,y color coordinates from the radiated spectrum. These color coordinates are then plotted on the CIE chromaticity diagram. A line is drawn from the illuminant C point through the x,y color point intersecting the perimeter of the diagram. The point where the line intersects the perimeter is the dominant wavelength, λ_d . The dominant wavelengths and corresponding colors for LEDs are shown on the CIE chromaticity diagram in Figure 19.

Also shown in Figure 18 is the color purity, or saturation, which is defined as the ratio of the distance from the x,y color point to the illuminant C point, divided by the sum of this distance and the distance from the x,y point to the perimeter. The x,y color coordinates for LEDs plot very close to the perimeter of the chromaticity diagram. Therefore, the color purity approaches a value of 1, typical of the color saturation obtained from a monochromatic light source. However, as discussed in the following section, this color purity is desaturated by reflected ambient light.

Chromatic Distance and the 1960 CIE-UCS Chromaticity Diagram: The ability of the eye to discern the color difference between the illuminated LED and the background can be evaluated by measuring the distance between their respective color coordinates. In this case, the 1931 CIE color system should not be used because the areas of unitary observed color differences are ellipses which leads to errors when using the distance between two color coordinates in the diagram as a measure of color difference.^[8] The 1931 system was reshaped in 1960 so that the areas of observed color difference are nearly circular. Although the 1960 Chromaticity Diagram was again reshaped in 1976 to a more uniform color space, a comparison between these two systems shows rather close agreement in red-green chromaticity difference perception and significant disagreement in blue-purple chromaticity difference perception.

In this diagram the distance between any two chromaticity coordinates in the green to red region can be considered a measure of their color difference. For example, Figure 21 shows the chromatic distance (EC) between a gray background and red LED. According to the Discrimination Index Theory, the chromatic distance between an illuminated

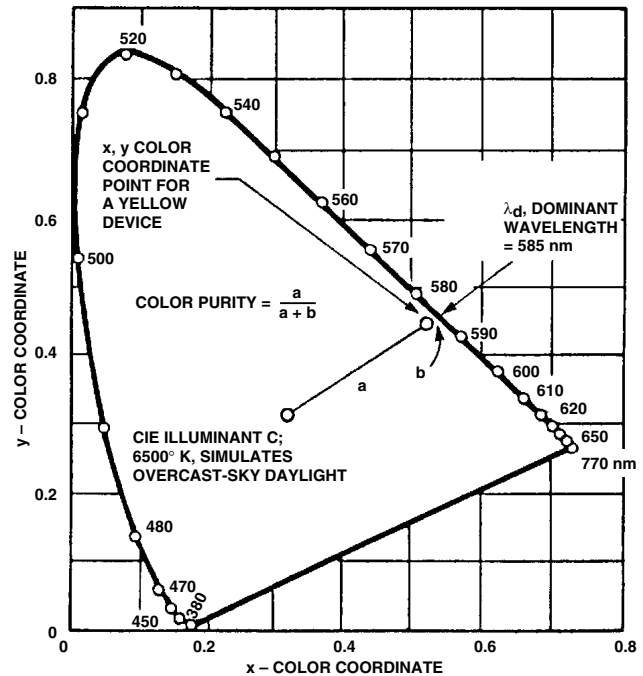

Figure 18. Definition of Dominant Wavelength and Color Purity, Shown on the CIE Chromaticity Diagram.

element and its background can be calculated using the following equation based on the 1960 CIE UCS Chromaticity Diagram.

(Chromatic Distance) EC =
$$\sqrt{(u_1 - u_b)^2 + (v_1 - v_b)^2} \quad (12)$$

Where (u_r, v_r) = Color of emitted light

(u_b, v_b) = Color of background reflected light

However, in actual practice, this chromatic distance is reduced by desaturation of the display color which occurs when ambient light is reflected off the front surface of the filter and the illuminated LED element. The amount of desaturation depends upon the luminance ratio between the LED emitted light and the reflected ambient light. To account for this effect, the Chromatic Distance (EC) equation must be re-written, where the terms u_{b1}, v_{b1} are the color coordinates of the mixture of emitted light and reflected light.

(Chromatic Distance) EC =
$$\sqrt{(u_{b1} - u_b)^2 + (v_{b1} - v_b)^2} \quad (13)$$

Where

(u_{b1}, v_{b1}) = Color mixture of emitted light and reflected light

(u_b, v_b) = Color of background reflected light

SYMBOL	COLOR NAME
R	RED
rO	REDDISH-ORANGE
O	ORANGE
yO	YELLOWISH-ORANGE
Y	YELLOW
gY	GREENISH-YELLOW
YG	YELLOW-GREEN
yG	YELLOWISH-GREEN
G	GREEN
bG	BLUISH-GREEN
BG	BLUE-GREEN
gB	GREENISH-BLUE
B	BLUE
pB	PURPLISH-BLUE
bP	BLUISH-PURPLE
P	PURPLE
rP	REDDISH-PURPLE
RP	RED-PURPLE
pR	PURPLISH-RED
pPK	PURPLISH-PINK
PK	PINK
OPK	ORANGE-PINK
C	CIE ILLUMINATED C

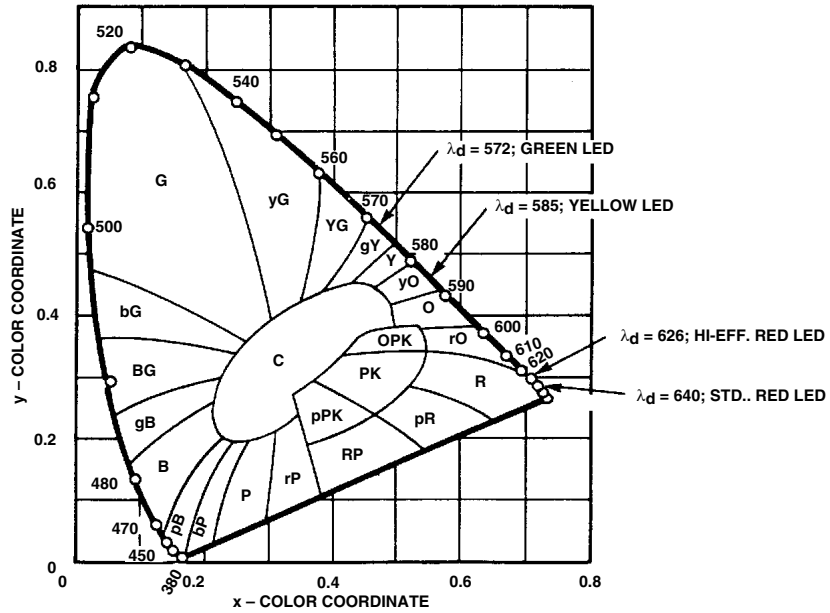

Figure 19. Dominant Wavelengths and Corresponding Colors for LEDs, Shown on the CIE Chromaticity Diagram.

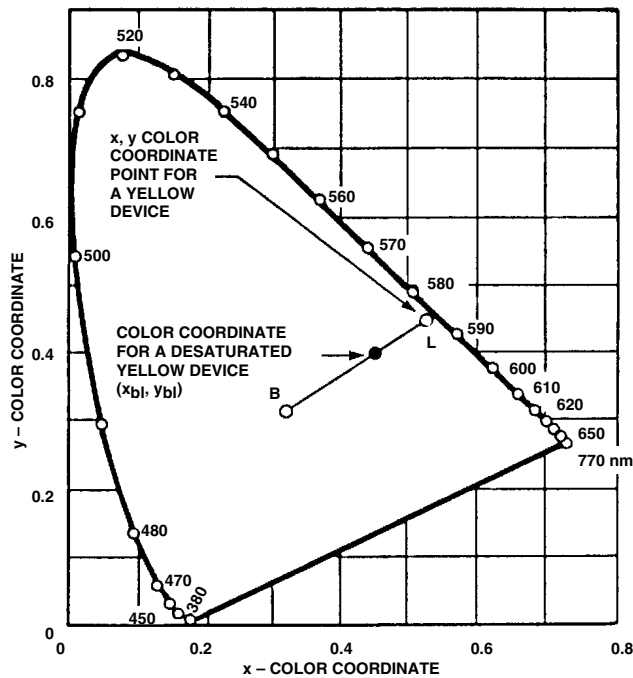

Figure 20. Additive Color Mixture.

The u and v coordinates used in the above equations can be calculated using the following principle illustrated in Figure 20, the 1931 Chromaticity Diagram.

The chromaticity coordinates representing the mixture of a light source which has luminance L and chromaticity coordinates (x_r, y_r) with a light source which has luminance

B and chromaticity coordinates (x_b, y_b) lies at point (x_{b1}, y_{b1}) on the straight line joining (x_r, y_r) and (x_b, y_b) . The exact point at which (x_{b1}, y_{b1}) lies depends upon the ratio of the luminances L and B .^[9] In this case, the ambient reflected light is specified by a sterance B and chromaticity coordinates x_b, y_b . The emitted light is specified by a sterance L and chromaticity coordinates x_r, y_r . The color produced by mixing the emitted light with the reflected ambient light is specified by:^[10]

The quantities L and B are in this case specified in cd/m^2 , however any units of luminous sterance such as footlamberts can be used.

The new chromaticity coordinates x_{b1} and y_{b1} are translated to the 1960 CIE (U, V) coordinate system. The background chromaticity coordinates x_b and y_b are also translated to u, v coordinates. The results (u_{b1}, v_{b1}) and (u_b, v_b) are used in the previously defined chromatic distance equation (13).

$$x_{b1} = \frac{M_1 x_1 + M_b x_b}{M_1 + M_b}$$

$$y_{b1} = \frac{M_1 y_1 + M_b y_b}{M_1 + M_b} \quad (14)$$

$$M_1 = \frac{L}{y_1} \quad M_b = \frac{B}{y_b}$$

* Note: See Appendix B for integrals used to calculate x, y chromaticity coordinates of background and illuminated element.

Chrominance Index

Threshold chrominance (ECTH), the smallest color difference the eye can discern, was determined by A.H. Jones in 1968 to equal 0.00384.^[11] Based on the assumption that comfortable color differences can be equated to comfortable luminance differences, Jean Pierre Galves and Jean Brun determined experimentally that the unitary color difference (ECU) for comfortable discernability is seven times the threshold chrominance difference (ECTH).

$$ECTH = 0.00384$$

$$ECU = 7 \times 0.00384 = 0.027 \quad (15)$$

The ratio of the chrominance difference of an actual display to the unitary chrominance difference (ECU) is called the chrominance index (IDC). A chrominance index of one would imply a display with a color difference just large enough for comfortable discernability. Any chrominance index greater than or equal to one is desirable.

Thus, the chrominance index for the illuminated element becomes:

(Chrominance Index) IDC =

$$\frac{EC}{ECU} = \frac{EC}{0.027} \quad (16)$$

$$IDC = \frac{EC}{0.027} = \frac{\sqrt{(u_{b1} - u_b)^2 + (v_{b1} - v_b)^2}}{0.027} \quad (17)$$

Chrominance Contrast of Red, Yellow, Green Displays and a Gray Background:

To increase chrominance contrast most Avago Technologies sunlight viewable displays are designed with a neutral gray background. Figure 21 shows the color coordinates for a typical gray background and for a red, yellow and green LED. As can be seen, the chromatic distance between the red LED and the gray background is 3 times the chromatic distance between the yellow LED and the gray background. The difference is even greater when the chromatic distance between a red LED and gray background and green LED and gray background are compared. Therefore, for equal sterance a red display has a chrominance contrast advantage over the yellow or green display. However, all displays can be viewable in sunlight ambients when appropriate filtering techniques are employed.

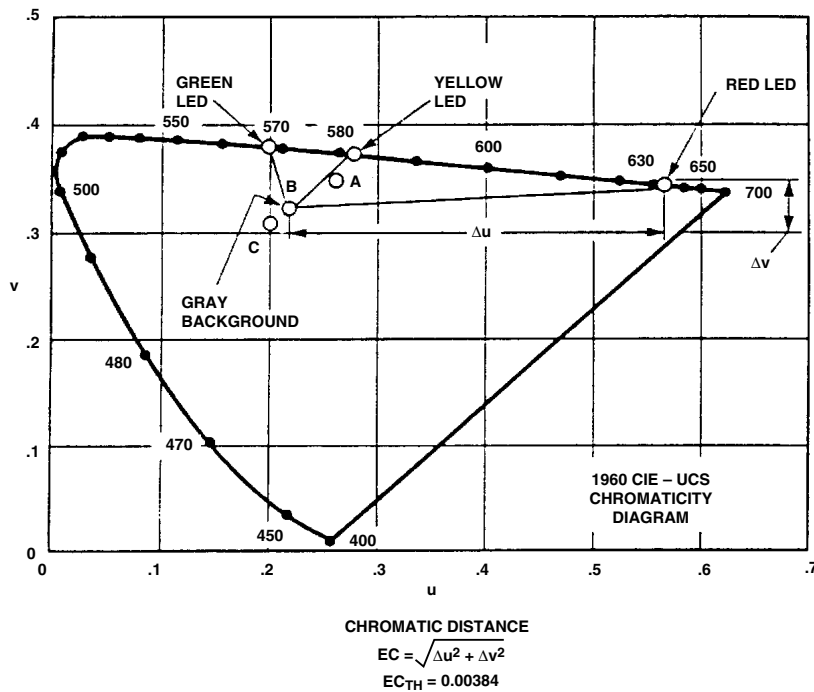

Figure 21. 1960 CIE-UCS Chromaticity Diagram with the Chromatic Distance Between a Green, Yellow or Red LED and a Gray Background.

Discrimination Index^[12]

The luminance and chrominance indices can be combined into a figure of merit for readability called the discrimination index. The minimum value of discrimination index for comfortable readability is achieved when either the luminance or chrominance indices are equal to unity.

$$ID = \sqrt{IDL^2 + IDC^2} \quad (18)$$

$$ID_{min} = 1.0$$

To visualize the total achieved contrast between the illuminated element and its background, the discrimination index may be plotted in the three dimensional 1960 CIE-UCS photolorimetric space. The photolorimetric space is defined in the horizontal plane by the 1960 (U,V) Chromaticity System and in the vertical plane by the logarithmic luminance scale.^[13] In Figure 22, the luminance index and chrominance index of the illuminated element is plotted as one point and the display background as another. The distance between these two distinct points is the discrimination index.

LED Seven Segment Display Example

LED Seven Segment Display Package

Seven Segment LED displays designed for high light ambient conditions can be used to illustrate the discrimination index theory. These displays are well suited for bright ambient applications due to the chrominance contrast provided by the display package and luminance contrast due to high brightness LEDs. The LEDs are large junction gallium phosphide chips which have high light

output and can be driven at increased drive currents. The segment cavities are designed to maximize sterance (intensity/unit area) as well as to maximize chrominance contrast. The color and reflective characteristics of the untinted epoxy segment nearly matches the color and reflectance of the gray painted background. Thus, the off segments blend into the back-, ground in the off condition and in the on condition the eye is not confused as to which segment is illuminated.

To determine sunlight readability of this particular display package diffuse and specular reflectance measurements, as defined in *Front Surface Reflectance* were taken on the gray paint and the epoxy. The diffuse measurements were taken using a MacBeth densitometer (RD-100R) which measures at an angle of 45° and the specular measurements were taken using the Avago Technologies 8450A spectrophotometer which measures at an angle of 30°.

Figure 23 shows the typical reflectance characteristics for the face of a gray body, seven segment display. The gray paint exhibited less than 0.02% specular reflectance and 9 - 12% diffuse reflectance. The epoxy was very close with less than 0.02% specular reflectance and 9% diffuse reflectance.

Filters for Contrast Enhancement — Seven Segment LED Displays

Background diffuse reflectances can be reduced to a low level by using a neutral density gray filter with 18 - 25% transmission across the visible spectrum. Besides attenuating reflected light off the display the neutral density gray filter enhances the chrominance contrast between the illuminated element and the gray display package.

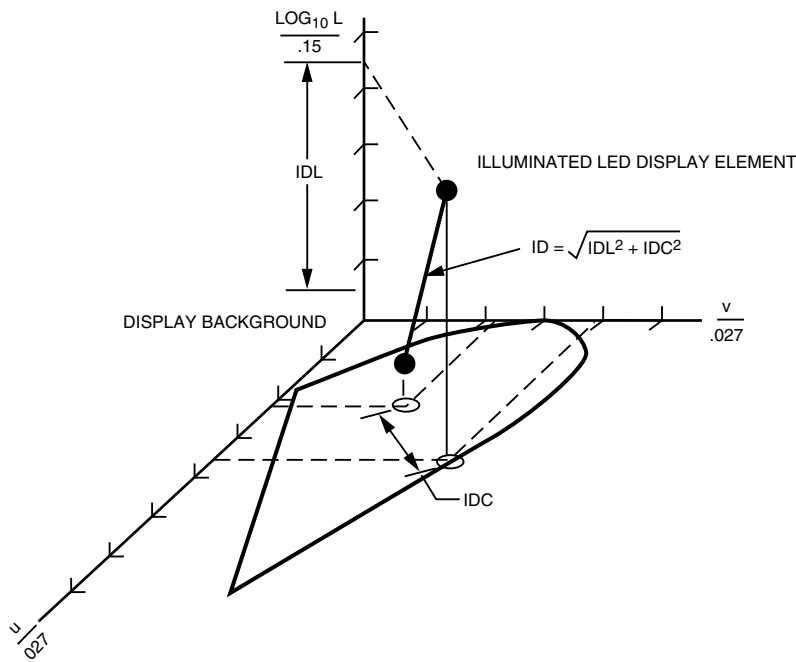

Figure 22. Photolorimetric Space.

Another consideration is the reflected ambient light, which will significantly reduce the contrast ratio and desaturate the color of the LED emitted light. In Table 5, typical values of diffuse and specular reflectance are shown for plastic filters with textured or untextured front surfaces.

The specular reflectance of either the untextured (4 - 6%) or textured (2 - 4%) filter is fairly high. Thus, when viewed at the angle of specular reflectance the glare off the filter will wash out the light emitting elements. However, untextured plastic filters are frequently used in bright sunlight. Untextured filters have a smooth front surface and therefore exhibit large amounts of specular reflectance and little diffuse reflectance. As long as the specular reflectances are directed away from the observer's view, the untextured filter will offer the advantage of minimizing diffuse reflectance. For example, the diagram in Table 5 shows how tilting the top of the filter slightly forward will direct specular reflectance downward, away from the observer's eyes.

The particular transmittance (15 - 25%) is dependent upon the filter front surface reflectance and desired front panel appearance. Plastic filters with low diffuse reflectance (0.3 - 0.7%) give best results at 18% transmission. This lower transmission of 18% will also produce a more noticeable dead front appearance than a 25% transmission filter.

Example — Seven Segment LED Display and Filter

In the following example, a 0.3-inch yellow LED seven segment display (HDSP-4030) is used with an 0.7% diffuse reflectance, neutral density gray untextured plastic filter with 23% transmission in an ambient of 107,000 lm/m² (10,000 foot-candles). Only diffuse reflectance is considered because the filter has been mounted such that specular reflectances are directed away from the eyes of the observer.

In Figures 24 through 28 luminance, chrominance and discrimination indices are calculated for two conditions. First, with no consideration of front surface reflectance and second, for a typical viewing condition where the observer only sees diffuse reflectance. As can be seen, the value of each index is reduced by front surface reflectance. If an engineer fails to consider front surface reflectance in his calculations, he may be misled in two ways. First, he may believe that a contrast ratio of 1.79:1 can be achieved. However, when diffuse reflectance is considered, the contrast ratio is reduced to 1.42:1. Second, he may also believe that the chromatic distance between the illuminated LED and the background is 0.0853. However, when desaturation due to diffuse reflectance is considered the chromatic distance is reduced to 0.0229.

Finally, when the contrast ratio and chromatic distance are combined into the discrimination index, the consequences of front surface reflectance are evident. The discrimination index without front surface reflectance is 1.58. When front surface reflectance is considered, the discrimination index is reduced to 1.31, which is still above the minimum of 1.0 for comfortable readability. Although the discrimination index of 1.31 is lower than 1.58, it is a more realistic value of the discrimination index perceived by the eye.

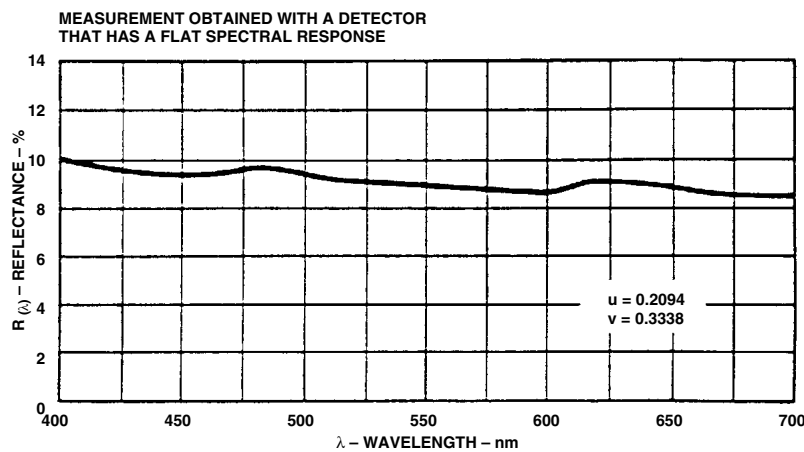

Figure 23. Reflectance Characteristic for the Face of a Gray Body Stretched Segment Sunlight Viewable LED Display.

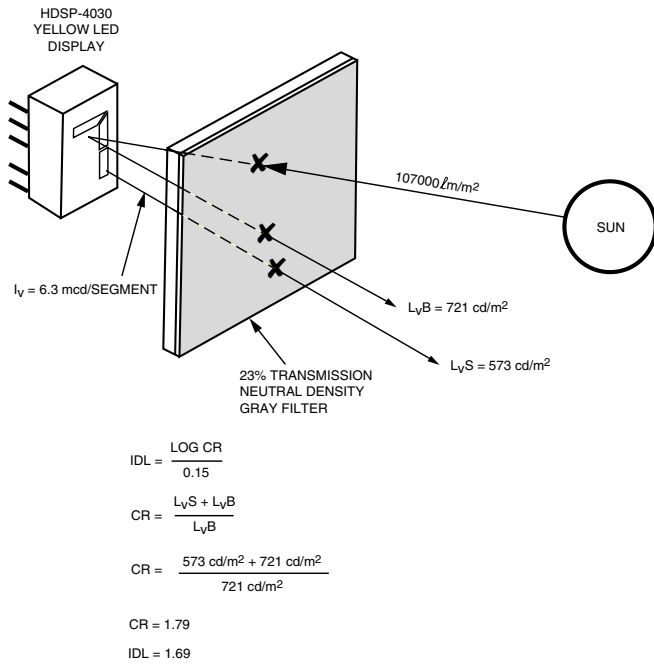

Figure 24. Luminance Index — No Front Surface Reflectance.

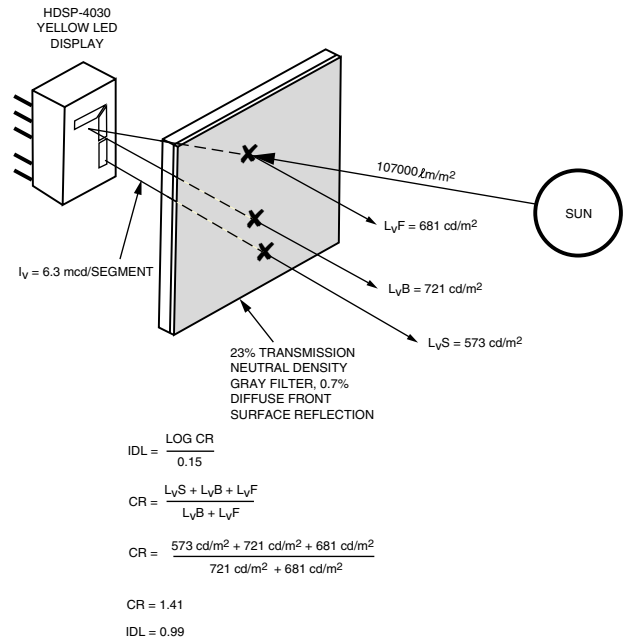
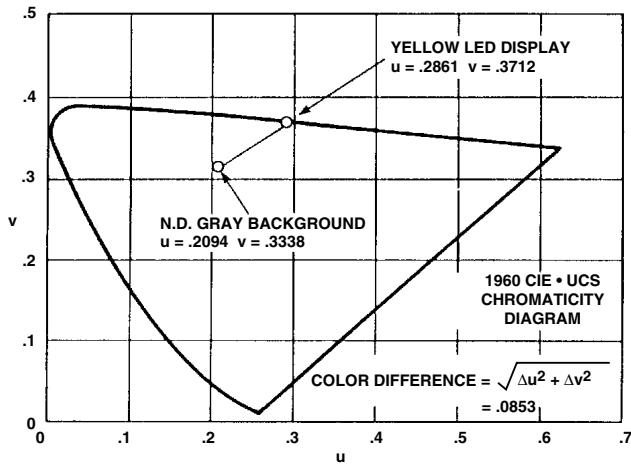

Figure 25. Luminance Index — Diffuse Front Surface Reflectance.



COLOR ON SEGMENT = COLOR LED
 12% BACKGROUND REFLECTANCE
 NO FRONT SURFACE REFLECTANCE

$$IDC = \frac{\sqrt{\Delta u^2 + \Delta v^2}}{0.027}$$

$$\frac{\sqrt{\Delta u^2 + \Delta v^2}}{0.027} = 0.0853$$

$$IDC = \frac{0.0853}{0.027}$$

$$IDC = 3.16$$

Figure 26. Chrominance Index — No Front Surface Reflectance.

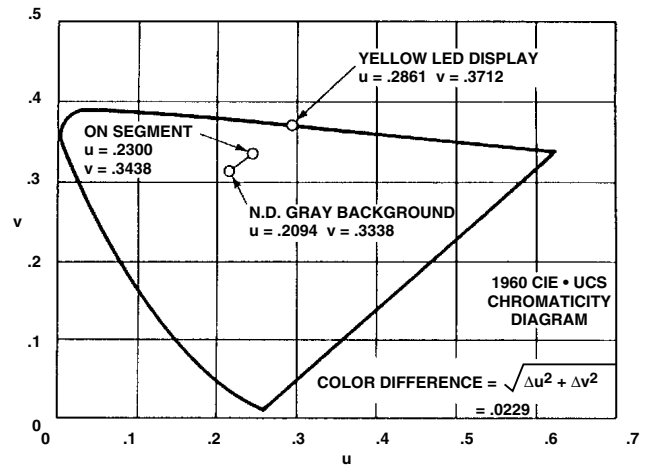

COLOR ON SEGMENT = COLOR LED + COLOR REFLECTIONS
 12% BACKGROUND REFLECTANCE
 .7% DIFFUSE FRONT SURFACE REFLECTANCE

$$IDC = \frac{\sqrt{\Delta u^2 + \Delta v^2}}{0.027}$$

$$\frac{\sqrt{\Delta u^2 + \Delta v^2}}{0.027} = 0.0229$$

$$IDC = \frac{0.0229}{0.027}$$

$$IDC = 0.848$$

Figure 27. Chrominance Index — Diffuse Front Surface Reflectance.

Table 5. Typical Values of Diffuse and Specular Reflectance for Plastic Filters.

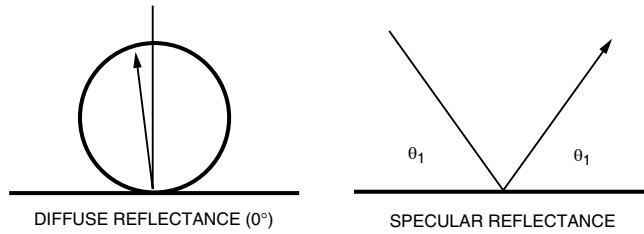

PLASTIC FILTER	DIFFUSE REFLECTANCE AT 0°	SPECULAR REFLECTANCE	
		10°	30°
UNTEXTURED	0.3 – 1.0%	3.0 – 5.0%	4.0 – 6.0%
TEXTURED	0.6 – 1.3%	1.0 – 3.0%	2.0 – 4.0%

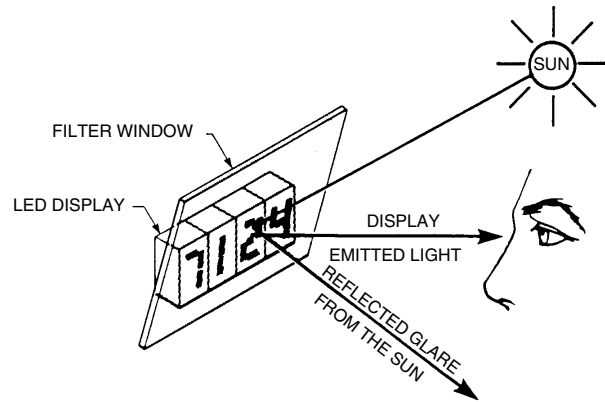

NOTE:
A FILTER WINDOW CANTED FORWARD WITH RESPECT TO THE PLANE OF THE FACE OF THE DISPLAY DIRECTS REFLECTION AWAY FROM THE EYES OF AN OBSERVER.

Filter Recommendations for Seven Segment Displays

Plastic, 0.7% Diffuse Reflectance

To obtain filter recommendations for design engineers, three red, yellow, and green seven segment displays were modeled in a computer program in the same fashion as the previous example. A variety of untextured plastic filters, each with a typical diffuse front surface reflectance of 0.7% were also modeled, and discrimination indices calculated in an ambient of 107,000 lm/m² (10,000 foot-candles). Based on the discrimination index theory and observation at Avago Technologies, the following recommendations are suggested to maximize readability.

For High Efficiency Red Seven Segment Displays, A Neutral Density Gray Filter or Double Band Pass Filter Produces Highest Values of Discrimination Index (see Figure 29).

Figure 29 summarizes luminance, chrominance and discrimination indices for neutral density gray (23%T), long pass (70%T at LED peak), and double band pass (520-560 nm 30%T, 610 - 660 nm 30%T) filters. The chrominance index of the neutral density gray filter is seven times

the chrominance index of the long pass red filter. This is because the color of the display background is a function of its reflectivity and the wavelengths of reflected light. The gray background of seven segment displays reflects all wavelengths of visible light equally. The neutral density gray filter also attenuates all wavelengths of visible light equally, and therefore, the display background maintains its original gray color. This is advantageous because the large color difference between the gray background and red illuminated LED improves readability.

On the other hand, the long pass red filter does not attenuate all wavelengths of visible light equally. It passes wavelengths only in the red region which causes the gray display background to appear red in color. For this reason, red filters that are perfectly acceptable indoors are difficult to use in bright sunlight, where there is very little color difference between the red background and the red illuminated LED.

A theoretical double band pass filter was also programmed into the computer. The idea was to create a greater chrominance difference between the illuminated element and the background by passing more reflected light at a wavelength other than that of the illuminated LED. In this case, a chrominance index of 4.03 was achieved in comparison to a chrominance index of 3.07 for a neutral density gray filter. The resulting discrimination index of 4.17 is larger than the discrimination index of 3.21 for a neutral density gray filter. This double band pass filter may be achievable by placing a purple filter (50%T) behind a neutral density gray filter (45%T).

$$ID = \sqrt{IDL^2 + IDC^2}$$

HDSP-4030 @ 6.3 mcd/SEGMENT NO FRONT SURFACE REFLECTANCE	HDSP-4030 @ 6.3 mcd/SEGMENT 0.7% DIFFUSE FRONT SURFACE REFLECTANCE
IDL = 1.69	IDL = 0.99
IDC = 3.16	IDC = 0.85
$ID = \sqrt{1.69^2 + 3.16^2}$	$ID = \sqrt{0.99^2 + 0.85^2}$
ID = 3.58	ID = 1.31

Figure 28. Discrimination Index Calculations for no Front Surface Reflectance and for Diffuse Front Surface Reflectance.

For Yellow Seven Segment Displays a Combination Neutral Density Gray/Amber or Neutral Density Gray Filter Produces High Values of Discrimination Index (see Figure 30).

The value of discrimination index for a neutral density gray/amber filter with 20% transmission at the LED peak is 1.50; and for a neutral density gray filter with 23% transmission across the visible spectrum is 1.31. Of these two filters the luminance and chrominance indices of the amber/neutral density gray filter is slightly higher than the luminance and chrominance indices of the neutral density gray filter. Either filter is acceptable depending on the desired front panel appearance.

For Green Seven Segment Displays a Neutral Density Gray Filter Produces Highest Values of Discrimination Index (see Figure 31).

A neutral density gray filter with 23% transmission across the visible spectrum produces a discrimination index of 1.10. Another possibility is a double band pass filter which would increase the chrominance difference between the illuminated LED and the background by passing reflected light of a wavelength other than that of the illuminated LED. However, the feasibility of production and expense of this filter may not warrant its development for use with green seven segment displays.

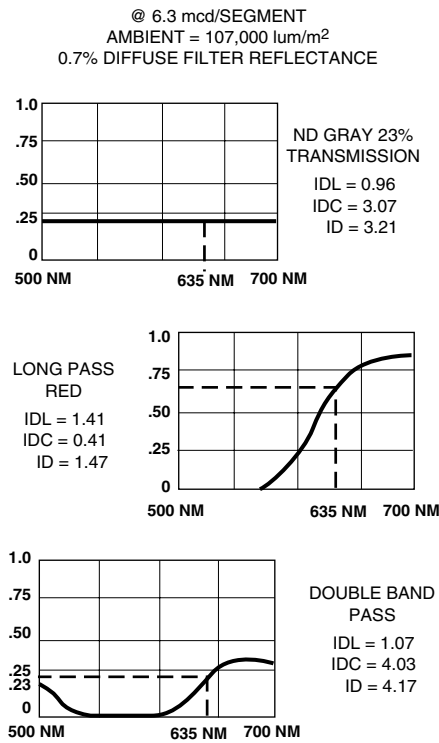

Figure 29. HDSP-3530 High Efficiency Red 0.30 inch Display.

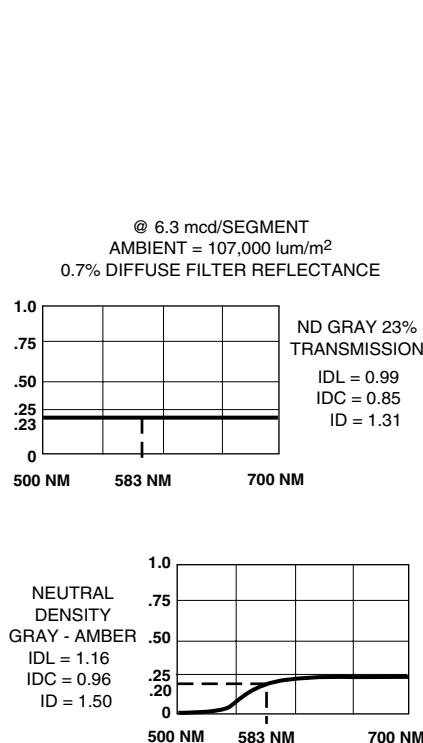

Figure 30. HDSP-4030 Yellow 0.30 inch Display.

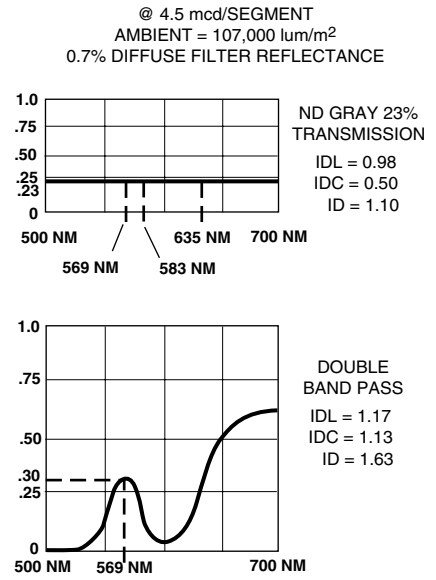

Figure 31. HDSP Green 0.30 inch Display.

Plastic, Louvered Filters

A louvered filter operates similarly to a venetian blind. As shown in Figure 32, light from the LED display passes between the louvers to the observer. On the other hand, incoming off-axis ambient light is blocked by the louvers and therefore is not reflected off the face of the display back to the observer. Although this results in a very high contrast ratio, the trade-off is a restricted viewing angle. For example, the zero degree louver filter shown in Figure 32 has a horizontal viewing angle of 180°, however, the vertical viewing included angle is 60°. The louver aspect ratio (louver depth/distance between louvers) determines viewing angle.

Some applications require a louver orientation other than zero degrees. For one example, an 18° louvered filter may be used on the sloping top surface of a point of sale terminal. A second example is the use of a 45° louvered filter on overhead instrumentation to block out ambient light from ceiling mounted lighting fixtures.

In bright sunlight, neutral density filters with transparent black louvers are most effective. A secondary colored filter may be placed behind the neutral density louvered filters to increase color contrast at the expense of LED emitted light. For sunlight applications, two different louver options are recommended. First a 45° neutral density louvered filter is recommended. This particular filter produces a horizontal and vertical included viewing angle of 60° for a louver aspect ratio of 2.75:1. Another possibility is a neutral density crosshatch filter which increases the contrast but further reduces the vertical and horizontal viewing angle to 40° for a louver aspect ratio of 2.75:1. A crosshatch filter is essentially two zero-degree neutral density louvered filters oriented at 90° to each other. With this filter, red, yellow and green digits mounted side by side will be clearly visible as long as the sunlight is not parallel to the viewing axis.

Louvered filters for LED displays are manufactured by 3M Company, Light Control Division, St. Paul, Minnesota.

AVAILABLE OPTIONS FOR LOUVERED FILTERS – ANY COMBINATION IS POSSIBLE

ASPECT RATIO AND VIEWING ANGLE	LOUVER ANGLE	LOUVER COLOR
2.75: 1 = 60°	0°	OPAQUE BLACK
2.00: 1 = 90°	18°	TRANSLUCENT GRAY
3.50: 1 = 48°	30°	TRANSPARENT BLACK
	45°	

EXAMPLE: 2.75: 1 – 18° – TRANSPARENT BLACK

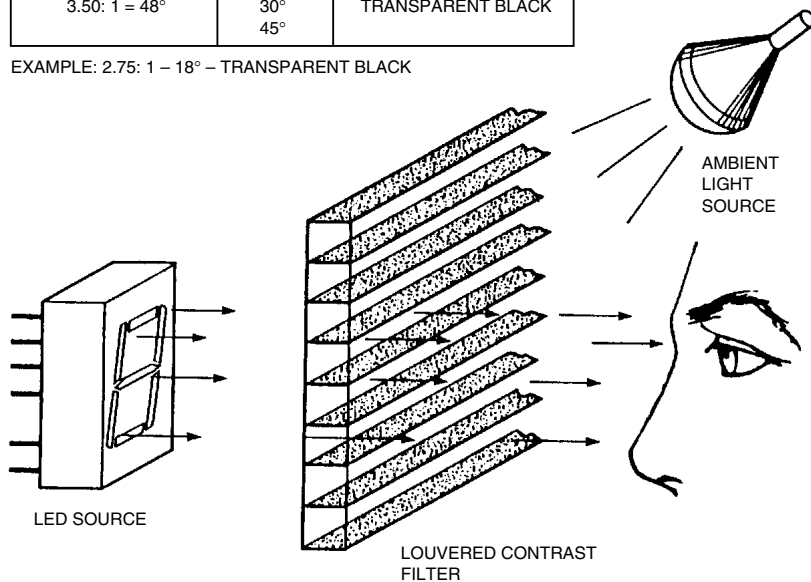

Figure 32. The Operation of a Louvered Filter.

Dot Matrix LED Display Example

Dot Matrix LED Display Package

Dot Matrix LED displays can also be used to illustrate the discrimination index theory. Figure 33 shows a particular dot matrix alphanumeric display, with four characters in each package. These displays are well suited for bright ambient applications due to the high sterance of each individual dot in the 5x7 matrix.

The display package consists of a dark ceramic substrate, 140 LED chips and two integrated circuits all covered by a transparent glass window.

the interconnecting gold traces reflect light. To determine sunlight readability of this particular package, specular and diffuse reflectance measurements were taken on each of the package materials. For this particular display package, the diffuse measurements were taken using a MacBeth densitometer (RD-100R) which measures at an angle of 45° and the specular measurements were taken using the Avago Technologies 8450A spectro-photometer which measures at an angle of 30°.

Figure 34 shows that without a filter this display has a high amount of specular reflectance due to the traces, LED chips, ICs and the glass window.

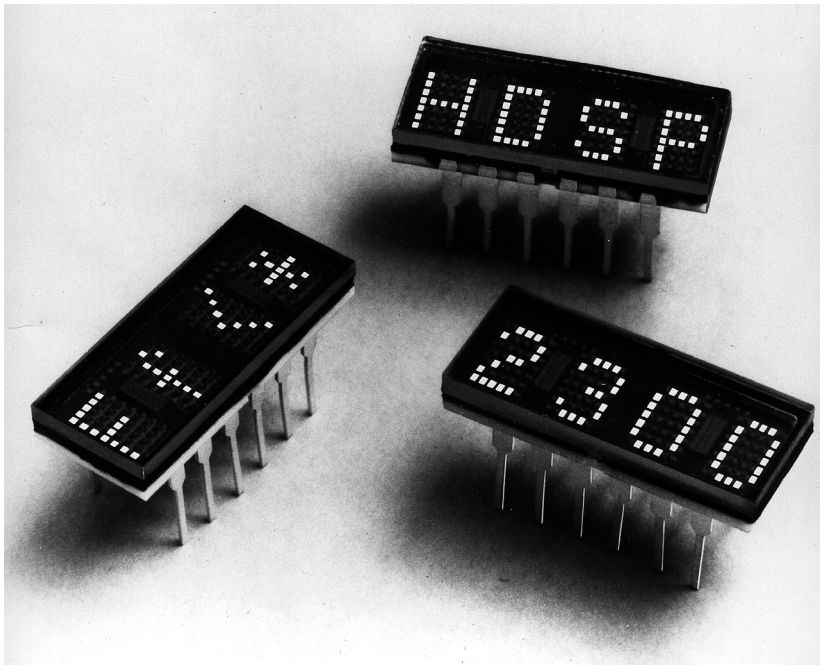

Figure 33. Small Alphanumeric Display.

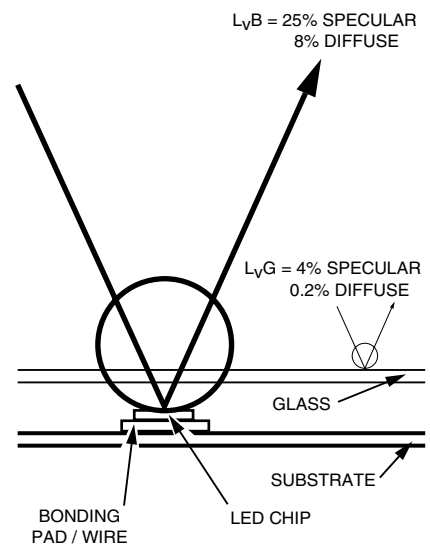

Figure 34. Dot Matrix Alphanumeric Display, Typical Values of Reflectance at 30°.

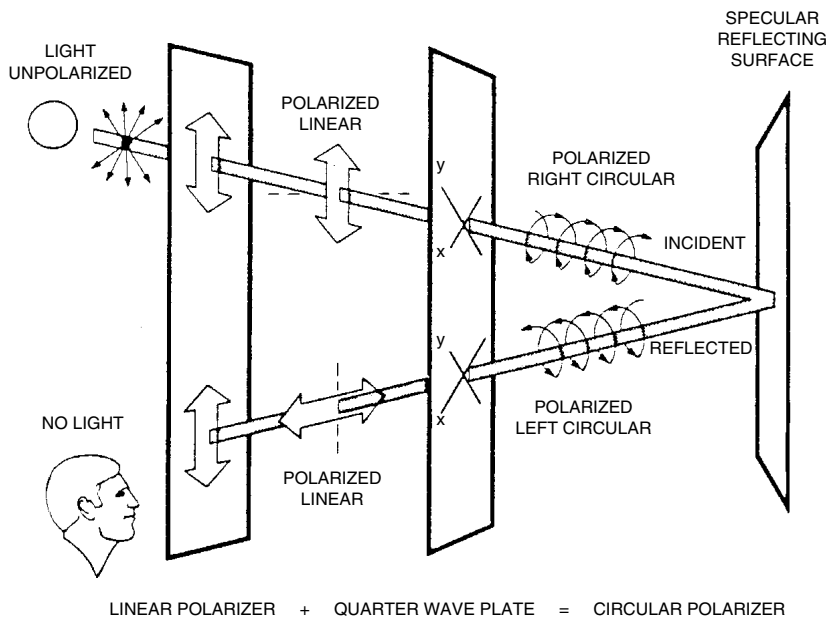

Figure 35. Operation of a Circular Polarizer.

Filters for Contrast Enhancement — Dot Matrix Display

Specular reflectances off the display package can be reduced to a very low level by using a circular polarizer. The circular polarizer shown in Figure 35 consists of a linear polarizer and a quarter wave plate laminated together. The linear polarization axis is oriented at 45° to the optical axis of the quarter wave plate. Non-polarized sunlight passing through the linear polarizer is broken into x and y components which emerge from the quarter wave plate, 90° out of phase, circularly polarized. Upon reflection by the specular reflecting display surface, the direction of this circular polarized light is reversed. Passing back through the quarter wave plate, the x and y components are placed back in phase, but since they are linearly polarized at 90° to the linear polarizer, this reflected light is absorbed by the filter.

Another consideration is the ambient light reflected off the front surface of the filter. Too much reflected ambient light will significantly reduce the contrast ratio and desaturate the color of the LED emitted light. Untextured plastic filters are frequently used, and they can perform quite well in bright sunlight if they are mounted in such a way as to direct specular reflectances away from the observer's eyes. For sunlight ambients where specular reflectance cannot be directed away from the observer's eyes, a glass filter with a quarter wavelength, anti-reflection coating can be used. This optical coating minimizes specular reflectances by reducing the apparent index of refraction of the glass filter to a value which closely approximates the index of refraction of air.

This index matching reduces the amount of LED emitted light lost at the glass to air interface and also reduces the amount of ambient light reflected off the front surface of the filter.

The amount of LED emitted light lost at the glass-to-air interface can be calculated by the index of refraction equation discussed in *Peak Wavelength and Filter Transmission*.

$$R = \left(\frac{n_1 - n_2}{n_1 + n_2} \right)^2 \quad (19)$$

Where

n_1 = index of refraction for filter material

n_2 = index of refraction for air

$$\text{Reflection Loss} = 2(R) (100\%) \quad (20)$$

For a clear uncoated glass the reflection loss as calculated below is 10.6%.

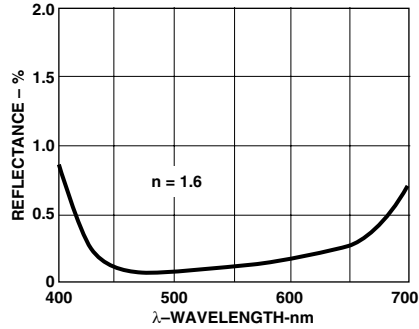

Figure 36. Front Surface Reflectance of Glass with Double Sided 1/4 Wave Optical Coating.

$$R = \left(\frac{1.6 - 1.0}{1.6 + 1.0} \right)^2 = 0.053 \quad (21)$$

Where

$n = 1.6$, a typical index of refraction for glass

$n = 1.0$, index of refraction for air

$$\text{Reflection Loss} = 2(0.053) 100\% = 10.6\% \quad (22)$$

In Table 6 typical values of specular and diffuse reflectance are shown for a commercial grade HEA coating supplied by Optical Coating Laboratories in Santa Rosa, California. The reflectance of the commercial grade HEA coating (#11-002A) was measured on a Gardner Hazeguard XL-211 Hazemeter (diffuse reflectance) and a Beckman DK2A Spectrophotometer (specular reflectance). As can be observed from the table, HEA coatings are most effective between 0 and 30°. Also shown on Table 6 are reflectance values for a military grade coating — data supplied by manufacturers of anti-reflection coatings. Since the values of specular reflectance are very low (0.20 - 0.45%), these filters can be used in diffuse as well as specular reflecting viewing conditions. As illustrated in Figure 36, the specular reflectance of the commercial grade coating (#11-002A) is typically 0.25% for any wavelength in the visible spectrum.

Table 6. Typical Values of Diffuse and Specular Reflectance for HEA Coatings.

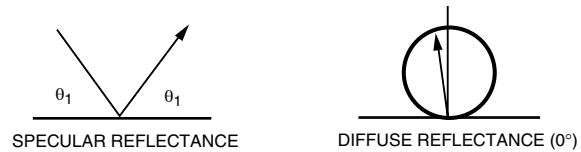

ANGLE OF INCIDENCE	SPECULAR REFLECTANCE		DIFFUSE REFLECTANCE
	COMMERCIAL GRADE	MILITARY GRADE	BOTH GRADES
10°	0.10%	0.05%	<0.02%
30°	0.25%	0.10%	0.02%
45°	0.45%	0.25%	0.04%

For a piece of optically coated clear glass, the amount of LED light lost at the glass-to-air interfaces due to reflection is 0.50%. A reflectance loss of 0.50% through a clear coated glass filter is considerably less than 10.6% for a clear uncoated glass filter.

$$R = \left(\frac{1.105 - 1.0}{1.105 + 1.0} \right)^2 = 0.0025 \quad (23)$$

Where

$n = 1.105$, a typical index of refraction for optically coated glass

$n = 1.0$, index of refraction for air

$$\text{Reflection Loss} = 2 (0.0025) (100\%) = 0.5\% \quad (24)$$

The amount of ambient light reflected off the face of an optically coated glass filter can also be calculated. The luminous sterance of the specular reflected glare in a 107,000 lm/m² ambient is 267 cd/m² for coated glass with 0.25% reflectance, which is considerably less than 2140 cd/m² for an untextured plastic filter with 2.0% reflectance or 4280 cd/m² for an uncoated piece of glass with 4.0% reflectance.

Several manufacturers produce filters consisting of a circular polarizer sandwiched between two pieces of glass, one of which is optically coated. The Polaroid HNCP10, a neutral density gray circular polarizing filter with 10-12% transmission across the visible spectrum is one such filter. Figure 37 is a cut away view of the filter, and Figure 38 portrays its spectral characteristics. The top curve depicts the transmission of unpolarized light (LED emitted light and diffuse reflectances), and the bottom curve the transmission of polarized light (specular reflectances). The bottom curve shows that specular reflectances from the glass window of the display, the top surfaces of the LEDs and the on board ICs are reduced to a very low level.

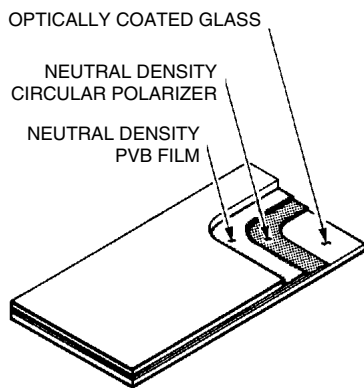

Figure 37. Circular Polarizer Laminated Between a Piece of HEA Coated Glass and a Piece of Uncoated Glass.

Example — Dot Matrix LED Display and Filter

In the following example, a 0.20 inch green LED alpha-numeric dot matrix display (HDSP-2303) is used with a 0.25% optically coated neutral density gray circular polarizing filter with 12 - 14% transmission in an ambient of 107,000 lm/m² (10,000 foot-candles). The angle chosen for analysis is 30° off axis. This represents the maximum angle at which anti-reflection coatings are still very effective.

In Figures 39, 40, and 41 luminance, chrominance and discrimination indices are calculated for three conditions. First, with no consideration of front surface reflectance, second, a typical viewing condition where the observer sees only diffuse reflectance and finally, a worst case viewing condition where the observer sees both diffuse and specular reflectance combined. The last two conditions are described and illustrated in the *Front Surface Reflectance* section. As can be seen, the value of each index is reduced by front surface reflectance. If an engineer fails to consider front surface reflectance in his calculations, he may be misled in two ways. First, he may believe that a contrast ratio of 7.43:1 can be achieved. However, when diffuse reflectance is considered, the contrast ratio is reduced to 7.23:1. When both diffuse and specular reflectances are considered, the contrast ratio is significantly reduced to 3.59:1. Second, he may also believe that the chromatic distance between the illuminated LED and the background is 0.0565. However, when desaturation due to diffuse reflectance is considered, the chromatic distance is reduced to 0.0493, and when both specular and diffuse reflectances are considered, the chromatic distance is further reduced to 0.0390.

Finally, when the contrast ratio and chromatic distance are combined into the discrimination index, the consequences of front surface reflectance are evident. The discrimination index without front surface reflectance is 6.18; with

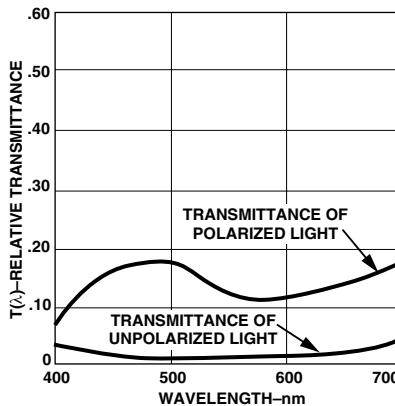
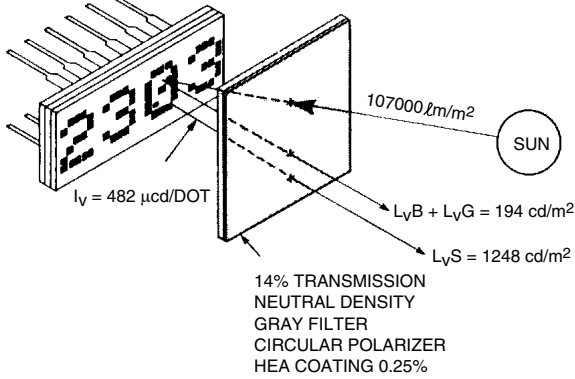

Figure 38. Spectral Characteristics of a Circular Polarizing Optically Coated Glass Filter.

HDSP-2303
GREEN DISPLAY



$$\text{CONTRAST} = \frac{L_vS + L_vB + L_vG}{L_vB + L_vG} = 7.43$$

NO FRONT SURFACE REFLECTANCE

$$\text{IDL} = \frac{\text{LOG CR}}{0.15}$$

$$\text{CR} = \frac{L_vS + L_vB + L_vG}{L_vB + L_vG}$$

$$\text{CR} = \frac{1248 \text{ cd/m}^2 + 194 \text{ cd/m}^2}{194 \text{ cd/m}^2}$$

$$\text{CR} = 7.43$$

$$\text{IDL} = 5.81$$

Figure 39a. Luminance Index — No Front Surface Reflectance.

HDSP-2303
GREEN DISPLAY

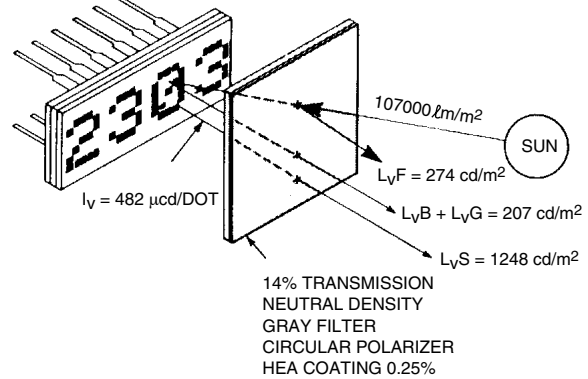

$$\text{CONTRAST} = \frac{L_vS + L_vB + L_vG + L_vF}{L_vB + L_vG + L_vF} = 3.59$$

DIFFUSE FRONT SURFACE REFLECTANCE

$$\text{IDL} = \frac{\text{LOG CR}}{0.15}$$

$$\text{CR} = \frac{L_vS + L_vB + L_vG + L_vF}{L_vB + L_vG + L_vF}$$

$$\text{CR} = \frac{1248 \text{ cd/m}^2 + 194 \text{ cd/m}^2 + 6.8 \text{ cd/m}^2}{194 \text{ cd/m}^2 + 6.8 \text{ cd/m}^2}$$

$$\text{CR} = 7.21$$

$$\text{IDL} = 5.72$$

DIFFUSE AND SPECULAR FRONT SURFACE REFLECTANCE

$$\text{IDL} = \frac{\text{LOG CR}}{0.15}$$

$$\text{CR} = \frac{L_vS + L_vB + L_vG + L_vF}{L_vB + L_vG + L_vF}$$

$$\text{CR} = \frac{1248 \text{ cd/m}^2 + 207 \text{ cd/m}^2 + 274 \text{ cd/m}^2}{207 \text{ cd/m}^2 + 274 \text{ cd/m}^2}$$

$$\text{CR} = 3.59$$

$$\text{IDL} = 3.70$$

Figure 39b. Luminance Index — Front Surface Reflectance.

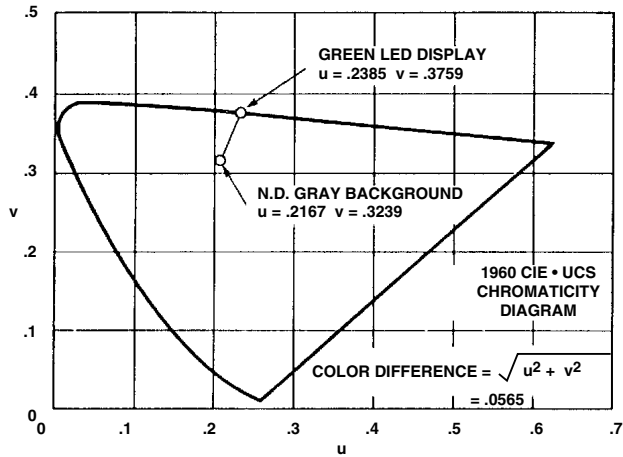

COLOR ON SEGMENT = COLOR LED
 BACKGROUND = 25% SPECULAR REFLECTANCE
 8% DIFFUSE REFLECTANCE

NO FRONT SURFACE REFLECTANCE

$$IDC = \frac{\sqrt{u^2 + v^2}}{0.027}$$

$$\sqrt{u^2 + v^2} = 0.0565$$

$$IDC = \frac{0.0565}{0.027}$$

$$IDC = 2.09$$

Figure 40a. Chrominance Index — No Front Surface Reflectance.

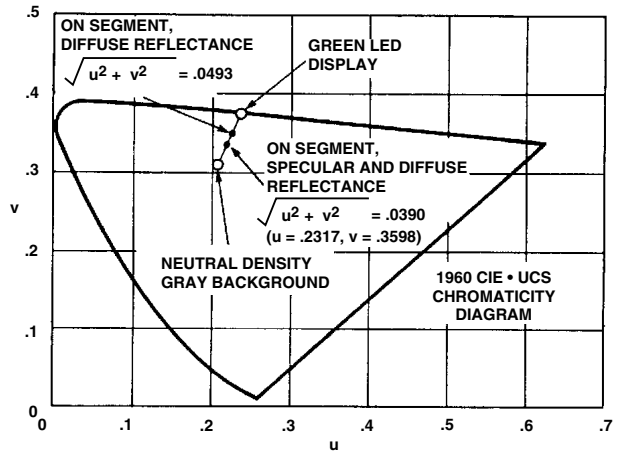

COLOR ON SEGMENT = COLOR LED + COLOR REFLECTANCE
 BACKGROUND = 25% SPECULAR REFLECTANCE
 8% DIFFUSE REFLECTANCE
 FILTER = .25% SPECULAR REFLECTANCE
 .02% DIFFUSE REFLECTANCE

DIFFUSE FRONT SURFACE REFLECTANCE

$$IDC = \frac{\sqrt{u^2 + v^2}}{0.027}$$

$$\sqrt{u^2 + v^2} = 0.0493$$

$$IDC = \frac{0.0493}{0.027}$$

$$IDC = 1.83$$

DIFFUSE AND SPECULAR FRONT SURFACE REFLECTANCE

$$IDC = \frac{\sqrt{u^2 + v^2}}{0.027}$$

$$\sqrt{u^2 + v^2} = 0.0390$$

$$IDC = \frac{0.0390}{0.027}$$

$$IDC = 1.44$$

Figure 40b. Chrominance Index — Front Surface Reflectance.

(HDSP-2303 AT 482 μ cd/DOT)
 NO FRONT SURFACE REFLECTANCE

$$IDL = 5.81$$

$$IDC = 2.09$$

$$ID = \sqrt{5.81^2 + 2.09^2}$$

$$ID = 6.18$$

Figure 41a. Discrimination Index — No Front Surface Reflectance.

(HDSP-2303 AT 482 μ cd/DOT)
 DIFFUSE FRONT SURFACE REFLECTANCE

$$IDL = 5.72$$

$$IDC = 1.83$$

$$ID = \sqrt{5.72^2 + 1.83^2}$$

$$ID = 6.00$$

(HDSP-2303 AT 482 μ cd/DOT)
 DIFFUSE AND SPECULAR FRONT SURFACE REFLECTANCE

$$IDL = 3.70$$

$$IDC = 1.44$$

$$ID = \sqrt{3.70^2 + 1.44^2}$$

$$ID = 3.97$$

Figure 41b. Discrimination Index — Front Surface Reflectance.

diffuse front surface reflectance is 6.0; and when both specular and diffuse reflectances are considered, it is 3.97. Although both 6.0 and 3.97 are lower numbers than 6.18, they represent more realistic values of the discrimination index perceived by the eye.

Filter Recommendations for Dot Matrix Displays (Circular Polarizers, Optically Coated Glass)

To determine filter recommendations for design engineers, three green, yellow, and high efficiency red alphanumeric displays were modeled in a computer program in the same fashion as the previous example. A variety of filters each consisting of a circular polarizer sandwiched between optically coated glass were also modeled, and discrimination indices calculated in an ambient of 107,000 lm/m² (10,000 foot-candles). Figures 42, 43, and 44 summarize the results for each of the three colors. Based on the discrimination index theory and observation at Avago Technologies, the following filter recommendations are suggested to maximize readability.

For Green Displays, a Neutral Density Gray or a Double Band Pass Filter may Increase the Discrimination Index (see Figure 42).

A neutral density gray filter with 14% transmission across the visible spectrum produces a discrimination index of 3.97.

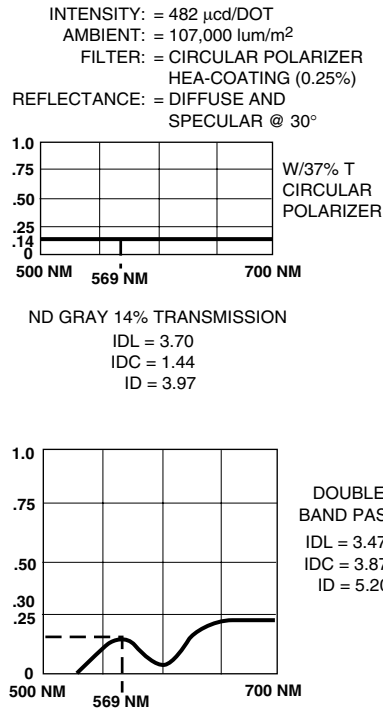

Figure 42. HDSP-2303 Green Alphanumeric 0.20 inch Display.

To increase the chrominance difference between the illuminated LED and the background by passing reflected light of a wavelength other than that of the illuminated LED, a double band pass filter was also modeled. In this case, a chrominance index of 3.87 was achieved in comparison to the chrominance index of 1.44 for a neutral density gray filter. This particular band pass filter passes 30% of the LED emitted light in a 20 nm bandwidth (560 - 580 nm) and 60% of the red ambient light in a 40 nm bandwidth (610 - 650 nm). The final discrimination index is 5.20.

For Yellow Displays, a Neutral Density Gray/Amber Filter Combination or a Neutral Density Gray Filter Yields High Values of Discrimination Index (see Figure 43).

The value of discrimination index for an amber/neutral density gray filter with 11% transmission at the LED peak is 3.32; and for a neutral density gray filter with 14% transmission across the visible spectrum, the discrimination index is 2.87. Of these two filters, the amber/neutral density gray filter used with a yellow LED display produces the highest values of chrominance and discrimination indices. Another possibility not shown in Figure 43 is a double band pass filter with 35% transmission between 570 - 590 nm and 60% transmission between 630 - 660 nm. Although this filter yielded highest values of discrimination index (3.81), it is questionable whether its development would be cost effective and if the added improvement would be significantly noticeable.

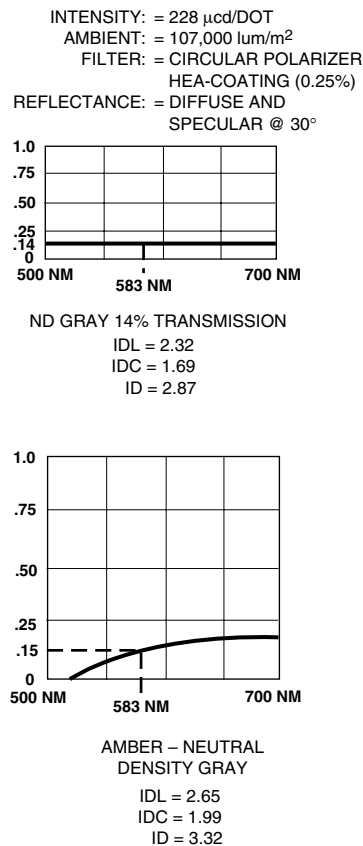

Figure 43. HDSP-2301 Yellow Alphanumeric 0.20 inch Display.

For High Efficiency Red Displays, a Neutral Density Gray Filter Produces High Values of Discrimination Index (see Figure 44).

Figure 44 summarizes luminance, chrominance and discrimination indices for neutral density gray (14%T), long pass (70%T at LED peak), and double band pass filters (520 - 560 nm 50%T, 610 - 660 nm 30%T). The chrominance index of the neutral density gray filter is ten times the chrominance index of the long pass red filter. This is because the color of the display background is a function of its reflectivity and the wavelengths of reflected light. The gray background of alphanumeric displays reflects all wavelengths of visible light equally. The neutral density gray filter also attenuates all wavelengths of visible light equally, and therefore, the display background maintains its original gray color. This is advantageous because the large color difference between the gray background and

red illuminated LED improves readability. On the other hand, the high pass red filter does not attenuate all wavelengths of visible light equally. It passes wavelengths only in the red region which causes the gray display background to appear red in color. For this reason, red filters that are perfectly acceptable indoors are difficult to use in bright sunlight, where there is very little color difference between the red background and the red illuminated LED.

A theoretical double band pass filter was also programmed into the computer. The idea was to create a greater chrominance difference between the illuminated element and the background by passing more reflected light at a wavelength other than that of the illuminated LED. In this case, a chrominance index of 6.50 was achieved in comparison to a chrominance index of 5.62 for a neutral density gray filter. This double band pass filter may be achievable by placing a purple filter (50%T) behind a neutral density gray filter (30%T).

General Conclusions

In the previous sections filter recommendations that pertain specifically to seven segment displays and alphanumeric displays have been discussed. There are also some general recommendations that should be followed when choosing any LED display and filter for use in a bright sunlight ambient. The four most important general recommendations are discussed in this section.

Front Surface Filter Reflectance Should be Reduced (see Figure 45)

This is important because as the front surface reflectance is reduced, the discrimination index increases. For example, an uncoated neutral density circular polarizing glass filter (14%T) with 4.0% specular reflectance provides a discrimination index of 0.82. This same glass filter with an optical coating of 0.45% provides a discrimination index of 3.23. On the other hand, the same filter with a coating of 0.25% provides a discrimination index of 3.97, while a military grade circular polarizing coated filter of 0.10% provides a discrimination index of 4.86.

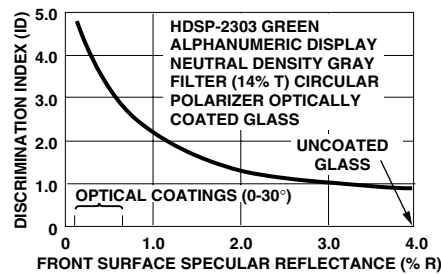
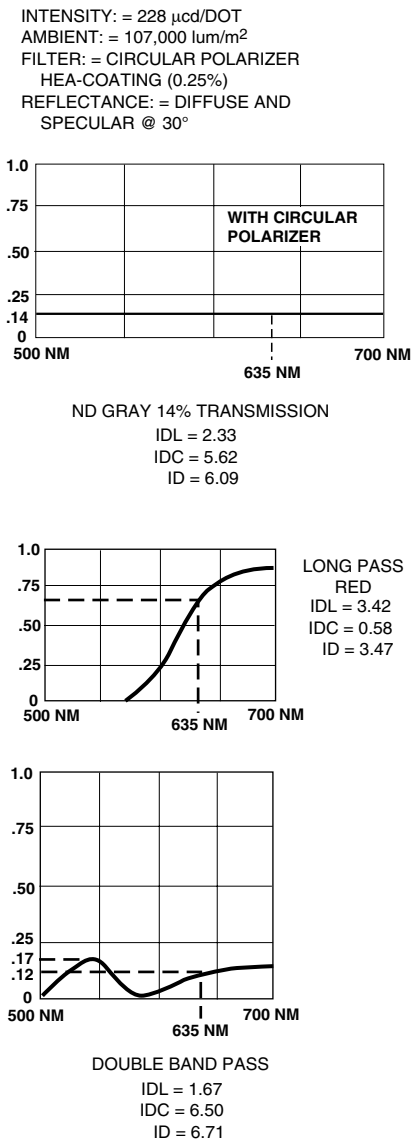

Figure 45. Effect of Reducing Front Surface Reflectance.

Figure 44. HDSP-2302 High Efficiency Red 0.20 inch Display.

For a Given Front Surface Filter Reflectance, The Optimal Neutral Density Gray Filter Transmission Can be Determined (see Figure 46).

The optimal neutral density gray filter transmission is dependent upon the amount of front surface filter reflectance and the reflectance of the materials in the display package.

As an example, a plastic neutral density gray filter with 0.7% diffuse reflectance used with a yellow seven segment display has an optimal transmission of 18-23%. This produces a discrimination index of 1.31 for a 23% transmission filter. A significantly lower transmission filter of 10% will attenuate display emitted light too much in comparison to the amount of front surface reflected light, and its discrimination index will be less than 1.31. On the other hand, a significantly higher transmission filter of 60% will transmit too much background reflected light, so the discrimination index will also be less than 1.31.

As another example, a neutral density gray circular polarizing optically coated glass filter with 0.25% anti-reflection coating used with a green alphanumeric display has an optimal transmission of 10 - 14%. This produces a discrimination index of 3.97 for a 14% transmission filter. A significantly lower transmission filter of 6% will attenuate display emitted light too much in comparison to the amount of front surface reflected light, and its discrimination index will be less than 3.97. On the other hand, a significantly higher transmission filter of 40% will transmit too much background reflected light, so the discrimination index will also be less than 3.97.

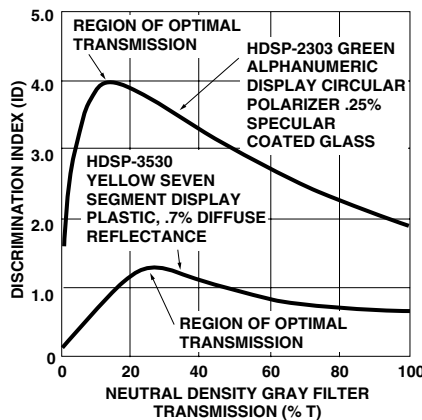

Figure 46. Optimal Neutral Density Gray Filter Transmission.

Reduce Incident Ambient Light When Possible (see Figure 47).

As shown in Figure 48, as ambient light is reduced, the discrimination index is increased. As an example, in an ambient of 107,000 lm/m^2 , the background reflected light off a gray bodied seven segment display is 721 cd/m^2 , plastic filter reflected light is 681 cd/m^2 and the discrimination index is 1.31. If the ambient is decreased to 50,000 lm/m^2 , the background reflected light is reduced to 337 cd/m^2 , filter reflected light to 318 cd/m^2 , and the discrimination index is increased to 2.29.

As a second example, in an ambient of 107,000 lm/m^2 , the background reflected light off an alphanumeric display is 207 cd/m^2 , optically coated filter reflected light is 274 cd/m^2 , and the discrimination index is 3.97. If the ambient is decreased to 70,000 lm/m^2 , the background reflected light is reduced to 135 cd/m^2 , filter reflected light to 180 cd/m^2 , and the discrimination index is increased to 4.91.

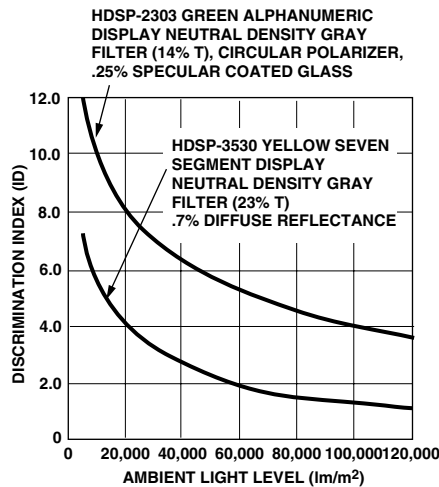

Figure 47. Effect of Reducing Ambient Lighting.

High Efficiency Red LEDs Produce Highest Values of Discrimination Index (see Figure 48).

For high efficiency red, yellow, and green seven segment displays of data sheet typical intensity, all filtered with a 23% transmission neutral density gray filter, discrimination index values are 3.21 for high efficiency red, 1.31 for yellow and 1.10 for green. The difference in discrimination indices is due to differences in chrominance indices. The chrominance index of a high efficiency red display is 3 times greater than the chrominance index of the yellow display. This is shown by referring back to the 1960 CIE chromaticity diagram (see Figure 21). On this diagram, the chromatic distance between the neutral density gray background and a red LED is approximately 3 times as large as the chromatic distance between the neutral density gray background and the yellow LED.

Similarly, for high efficiency red, yellow, and green alphanumeric displays of data sheet typical intensity, all filtered with a 14%T circular polarizing optically coated filter, the discrimination index values are 6.09 for high efficiency red, 2.87 for yellow and 3.97 for green. Again, the high efficiency red display has the greatest chrominance index followed by yellow and green respectively. In this case the discrimination index for the green display is greater than the yellow display due to the higher light output of green LEDs.

.3" Seven Segment Displays

Ambient: 107,000 lm/m²
Filter: Neutral Density Gray Plastic (23%T)
 0.7% Diffuse Filter Reflectance
Reflectance: Diffuse Only

LED Color	Device Intensity	Background Reflectance	Luminance Index	Chrominance Index	Discrimination Index
High Efficiency Red	6.3 mcd/seg	12%	0.96	3.10	3.21
Yellow	6.3 mcd/seg	12%	0.99	0.85	1.31
Green	4.5 mcd/seg	7%	0.98	0.50	1.10

.20" Alphanumeric Displays

Ambient: 107,000 lm/m²
Filter: Neutral Density Gray Glass (14%T)
 Circular Polarizer, Optically Coated Glass (0.25% Specular Reflectance)
Reflectance: Diffuse and Specular at 30°

LED Color	Device Intensity	Luminance Index	Chrominance Index	Discrimination Index
High Efficiency Red	228 μcd/DOT	2.33	5.62	6.09
Yellow	228 μcd/DOT	2.32	1.69	2.87
Green	482 μcd/DOT	3.70	1.44	3.97

Figure 48. Comparison of High Efficiency Red, Yellow, Green LED Displays at Typical Intensity Levels.

Table 7. A List of Neutral Density Filters For Use With Sunlight Viewable LED Displays

Filter Product	Manufacturer
H100-1266 Gray H100-1250 Gray H100-1230 Bronze (Plastic)	SGL HOMALITE 11 Brookside Drive Wilmington, DE 19804 (302) 652-3686
Plexiglas® 2074 Gray 2370 Bronze 2538 Gray (Plastic)	Rohm and Haas Independence Mall West Philadelphia, PA 19105 (215) 392-3000
Spectrafilter® Glax 105 (Plastic)	Chequers Engraving, Ltd 1-4 Christina Street, London EC2A 4PA 01 -739-6964/5
Panel Film® Light Control Film, (Louvered) ND0210 50% Gray ND0220 27% Gray (Plastic)	3M-Company Industrial Optics Carbonless, Related Products 225-35 3M Center St. Paul, MN 55144 (612) 733-4403
Chromafilter® Gray 15 Gray 10 (Plastic)	Panelgraphic Corporation 10 Henderson Drive West Caldwell, NJ 07006 (201) 277-1500
Optically Coated Glass HEA® Double Sided Antireflection Coating (Glass)	Optical Coating Laboratories, Inc 2789 Northpoint Parkway Santa Rosa, CA 95401-7397 (707) 545-6440
Optically Coated Glass With Circular Polarizer HNCP10 Gray (Glass and Plastic) HACP15 Amber/Gray With Circular Polarizer (Plastic)	Polaroid Corporation Technical Polarizer Division 1 Upland Road Norwood, MA 02062 (617) 769-6800
Optically Coated Glass With Circular Polarizer— Made to Customer Specification	Liberty Mirror, Division of Libbey-Owens-Ford Company Brackenridge, PA 15014 (412) 224-1800 Precision Glass Laminations 324 Yolando Santa Rosa, CA 95404 (707) 528-9070 Marks Polarized 153-16 10th Avenue Whitestone, NY 11357 (212)767-9600

Specific Manufacturers of Neutral Density Plastic and Glass Filters

Table 7 lists several neutral density filters that can be used with Avago Technologies Sunlight Viewable LED Displays. For increased contrast the neutral density filters can be combined with some of the wavelength filters listed in Table 4. For example, an amber filter combined with a neutral density filter can enhance chrominance contrast. In addition, Table 8 lists Avago Technologies displays that are specifically designed for Sunlight Ambient Applications.

Footnotes and References

1. Galves, Jean-Pierre, Brun, Jean. *Color and Brightness Requirements for Cockpit Displays: Proposal to Evaluate their Characteristics*. Twenty-ninth Agard Avionics Panel Technical Meeting.
2. *IES Lighting Handbook*, 5th ed., IES, New York, 1972
3. Wysecki, Gunter, Stiles, W.S. *Color Science Concepts and Methods, Quantitative Data and Formulas*, 1967. Chpt. 1, pp. 1-43.
4. Galves, op. cit.
5. Evans, Dave. *Sunlight Viewable Displays*, Optoelectronics Applications Manual, Section II. 1977 Avago Technologies.
6. Galves, op. cit., p 4.
7. Galves, op. cit., p. 5.
8. Judd, D.B. *Estimation of Chromaticity Differences and Nearest Color Temperature on the Standard 1931 (ICI) Colorimetric Coordinate System*, J. Opt. Soc. Am., pp. 421-426 (1936).
9. Hurvich, Leo. *Color Vision*, 1981, p. 292.
10. Merik, Boris. *Light and Color Measurements of Small Light Sources* General Electric, 1968. p. 97.
11. *For Color Television Cameras with Three Receptors*, Journal of the SMPTE, Volume 77, February 1968. pp. 108-115.
12. Galves, op. cit., p. 5.
13. Kowalski, P. *Equivalent Luminances of Colors*, Journal of the Optical Society of America, Vol. 59, No. 2, February 1969. p.129.

Appendix A

To calculate contrast ratio of a display the following integrals were used:

$$L_V S = 1/A \int I(\lambda) \bar{Y}(\lambda) T_1(\lambda) T_G(\lambda) d\lambda$$

$$L_V \text{OFF} = L_V \text{OFF Specular} + L_V \text{OFF Diffuse}$$

$$L_V \text{OFF Specular} = \int [S_B(\lambda) \bar{Y}(\lambda) \bar{R}_S(\lambda) T_G(\lambda)^2 + S_B(\lambda) \bar{Y}(\lambda) R_{GS}(\lambda)] T_1(\lambda) T_2(\lambda) d\lambda$$

$$L_V \text{OFF Diffuse} = 1/\pi \int [S_B(\lambda) \bar{Y}(\lambda) \bar{R}_D(\lambda) T_G(\lambda)^2 + S_B(\lambda) \bar{Y}(\lambda) R_{GD}(\lambda)] T_1(\lambda)^2 d\lambda$$

$$L_V B = L_V \text{OFF for purposes of the program}$$

$$L_V F = L_V F \text{ specular} + L_V F \text{ diffuse}$$

$$L_V F \text{ specular} = \int S_B(\lambda) \bar{Y}(\lambda) \bar{R}_{FS}(\lambda) d\lambda$$

$$L_V F \text{ diffuse} = 1/\pi \int S_B(\lambda) \bar{Y}(\lambda) \bar{R}_{FD}(\lambda) d\lambda$$

For Seven Segment Displays Only:

$L_V \text{OFF specular}$ and $L_V F \text{ specular}$ are ignored

$$T_G(\lambda) = T_2(\lambda) = 1$$

$$R_S(\lambda) = R_{GS}(\lambda) = R_{GD}(\lambda) = R_{FS}(\lambda) = 0$$

For Alphanumeric Displays Only:

$T_G(\lambda)$ = Transmission of glass window

$T_2(\lambda)$ = Transmission of filter polarized light

$R_S(\lambda)$ = Specular reflectance of ambient light off element

$R_{GS}(\lambda)$ = Specular reflectance of glass window

$R_{GD}(\lambda)$ = Diffuse reflectance of glass window

$R_{FS}(\lambda)$ = Specular reflectance of filter front surface

For Seven Segment Displays and Alphanumeric Displays:

A = Area of light emitting element

$I(\lambda)$ = LED radiometric spectrum

$\bar{Y}(\lambda)$ = 1931 CIE Photopic response curve

$T_1(\lambda)$ = Transmission of filter-unpolarized light

$S_B(\lambda)$ = Spectrum of CIE illuminant B — noon sunlight 4870° K

$R_D(\lambda)$ = Diffuse reflectance of ambient light off element

$R_{FD}(\lambda)$ = Diffuse reflectance of filter front surface

Appendix B

To calculate x, y chromaticity coordinates of an illuminated element and the background, the following integrals were used:

$$X_1 = 1/A \int \frac{K(\lambda)}{Y(\lambda)} \bar{X}(\lambda) d\lambda \quad Y_1 = L_V S$$

$$X_b = X_{OFF} = \int \frac{m(\lambda) + n(\lambda)}{Y(\lambda)} \bar{X}(\lambda) d\lambda$$

$$Y_b = Y_{OFF} = L_V OFF + L_V F$$

Where $X(\lambda) = 1931$ CIE Tristimulus Weighting Function

$Y(\lambda) = 1931$ CIE Photopic Response Curve

$K(\lambda) = I(\lambda)Y(\lambda)T_1(\lambda)T_G(\lambda)$

$m(\lambda) = [S_b(\lambda)Y(\lambda)R_s(\lambda)T_G(\lambda)^2 + S_b(\lambda)Y(\lambda)R_{GS}(\lambda)]$

$$T_1(\lambda)T_2(\lambda) + 1/\pi [S_b(\lambda)Y(\lambda)R_D(\lambda)T_G(\lambda)^2 + S_b(\lambda)Y(\lambda)R_{GD}(\lambda)]T_1(\lambda)^2$$

$$n(\lambda) = S_b(\lambda)Y(\lambda) [R_{FS}(\lambda) + 1/\pi R_{FD}(\lambda)]$$

Chromaticity Coordinates

$$x_1 = \frac{X_1}{X_1 + Y_1} \quad y_1 = \frac{Y_1}{X_1 + Y_1}$$

$$x_b = x_{OFF} = \frac{X_b}{X_1 + Y_b} \quad y_b = y_{OFF} = \frac{Y_b}{X_b + Y_b}$$

Finally, x, y, chromaticity coordinates are translated to 1960 CIE (U, V) coordinate system

$$u = \frac{4x}{(12y - 2x + 3)} \quad v = \frac{6y}{(12y - 2x + 3)}$$

Where $X(\lambda) = 1931$ CIE Tristimulus Weighting Function

$Y(\lambda) = 1931$ CIE Photopic Response Curve

$K(\lambda) = I(\lambda)Y(\lambda)T_1(\lambda)T_G(\lambda)$

$m(\lambda) = [S_b(\lambda)Y(\lambda)R_s(\lambda)T_G(\lambda)^2 + S_b(\lambda)Y(\lambda)R_{GS}(\lambda)]$

$$T_1(\lambda)T_2(\lambda) + 1/\pi [S_b(\lambda)Y(\lambda)R_D(\lambda)T_G(\lambda)^2 + S_b(\lambda)Y(\lambda)R_{GD}(\lambda)]T_1(\lambda)^2$$

$$n(\lambda) = S_b(\lambda)Y(\lambda) [R_{FS}(\lambda) + 1/\pi R_{FD}(\lambda)]$$

Chromaticity Coordinates

For product information and a complete list of distributors, please go to our web site: www.avagotech.com