

HSMF-C125

Tri-Color Surface-Mount ChipLED

Description

The Broadcom[®] HSMF-C125 is a 6-pin tri-color RGB chipLED with a 1.6-mm × 1.6-mm footprint. Its low package height of 0.4 mm makes this product an ideal solution for applications that have head room constraints, such as wearables and handheld portable devices.

Its small form factor with individually addressable pin-out for each color offers great design flexibility to the user. This chipLED offers industry leading light output performance by using efficient and high brightness AlInGaP and InGaN LED materials.

This chipLED is compatible with reflow soldering process. For easy pick-and-place, the parts are packed in tape and reel. Every reel is shipped from a single intensity and color bin for better uniformity control.

Features

- LED with AlInGaP/InGaN die
- Small form factor with individually addressable pin-out for all three colors
- Compatible with reflow soldering
- Available in 8-mm carrier tape on 7-in. diameter reels

Applications

- Backlighting
- Indicator

CAUTION! This LED is Class 1A ESD sensitive per ANSI/ESDA/JEDEC JS-001. Observe appropriate precautions during handling and processing. Refer to Application Note AN-1142 for additional details.

Figure 1: Package Dimensions

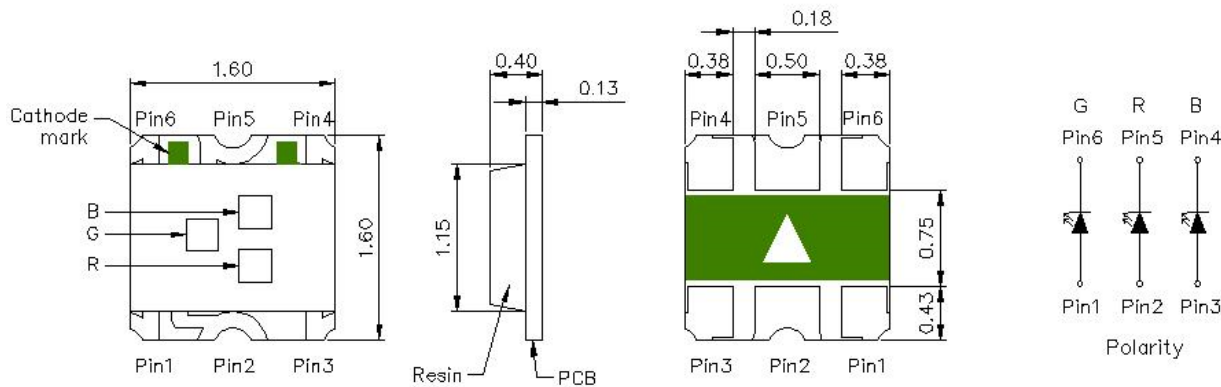
**NOTE:**

1. All dimensions are in millimeters.
2. Tolerance ± 0.1 mm unless otherwise specified.

Absolute Maximum Value at $T_J = 25^\circ\text{C}$

Parameter	AllInGaP Red	InGaN Green	InGaN Blue	Units
DC Forward Current ^{a, b}	20	20	10	mA
Power Dissipation ^a	48	78	39	mW
Forward Current ^{c, d}	15	15	10	mA
Power Dissipation ^c	40	58	39	mW
Junction Temperature	95			$^\circ\text{C}$
Operating Temperature	-40 to +85			$^\circ\text{C}$
Storage Temperature	-40 to +85			$^\circ\text{C}$

- a. Applies when one color is lit up.
- b. Derate as shown in [Figure 10](#)
- c. Applies when all three colors are lit up simultaneously.
- d. Derate as shown in [Figure 11](#).

Optical Characteristics ($T_J = 25^\circ\text{C}$, $I_F = 10$ mA)

Color	Luminous Intensity I_V (mcd) ^a		Dominant Wavelength λ_d ^b (nm)	Peak Wavelength λ_p (nm)	Viewing Angle $2\theta_{1/2}$ ^c (Degrees)
	Min.	Max.	Typ.	Typ.	Typ.
Red	45.0	180.0	623	630	130
Green	112.5	360.0	522	515	150
Blue	28.5	112.5	467	461	150

- a. The luminous intensity, I_V , is measured at the mechanical axis of the LED package. The actual peak of the spatial radiation pattern may not be aligned with the axis.
- b. The dominant wavelength, λ_d , is derived from the CIE Chromaticity Diagram and represents the perceived color of the device.
- c. $\theta_{1/2}$ is the off-axis angle where the luminous intensity is $\frac{1}{2}$ the peak intensity.

Electrical Characteristics at $T_J = 25^\circ\text{C}$, $I_F = 10\text{ mA}$

Color	Forward Voltage V_F (Volts) ^a		Reverse Current I_R^b (μA) at $V_R = 5\text{V}$	Thermal Resistance $R_{\theta\text{J-S}}$ ($^\circ\text{C/W}$)
	Min.	Max.	Max.	Typ.
Red	1.90	2.40	100	400
Green	2.7	3.90	100	400
Blue	2.7	3.90	100	400

a. Forward voltage tolerance: $\pm 0.1\text{V}$.

b. Reverse voltage indicates product final test. Long-term reverse bias is not recommended.

Bin Information

Intensity Bin (CAT)

Bin ID	Luminous Intensity (mcd)	
	Min.	Max.
N	28.5	45.0
P	45.0	71.5
Q	71.5	112.5
R	112.5	180.0
S	180.0	285.0
T	285.0	360.0

Tolerance $\pm 15\%$.

Color Bin (BIN) – Red

Bin ID	Dominant Wavelength (nm)	
	Min.	Max.
AC	615	630

Tolerance $\pm 1\text{ nm}$.

Color Bin (BIN) – Green

Bin ID	Dominant Wavelength (nm)	
	Min.	Max.
B	520	525
C	525	530
D	530	535
E	535	540

Tolerance $\pm 1\text{ nm}$.

Color Bin (BIN) – Blue

Bin ID	Dominant Wavelength (nm)	
	Min.	Max.
AA	460	465
AB	465	470
AC	470	475
AD	475	480

Tolerance $\pm 1\text{ nm}$.

CAUTION!

- The above optical performance specifications are valid in the case when a single color is illuminated.
- The above product specifications *do not* provide any guarantee on color mixing, color consistency over time or uniformity in luminous intensity when more than one color is illuminated.

Figure 2: Spectrum

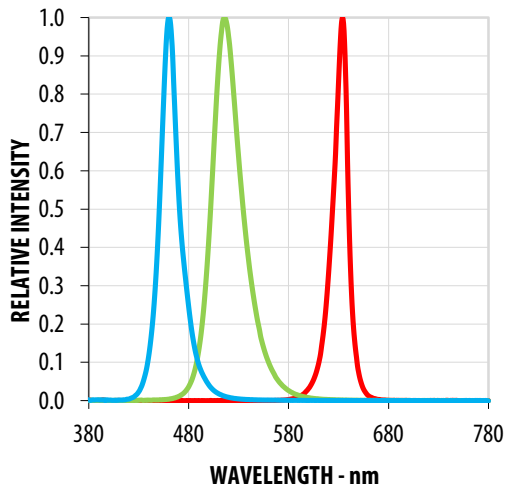

Figure 3: Relative Intensity vs. Forward Current

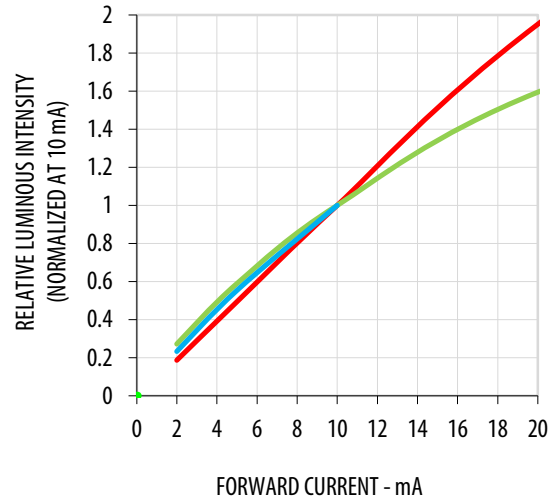

Figure 4: Forward Current vs. Forward Voltage

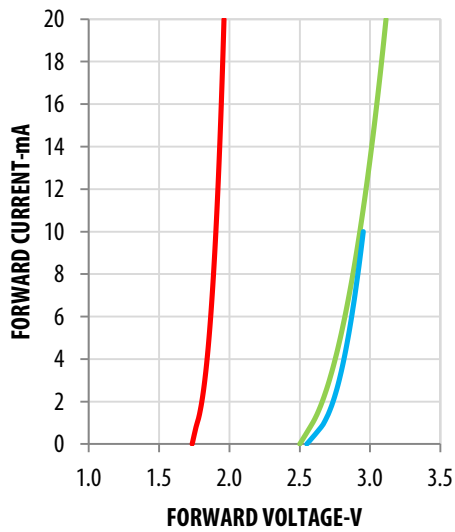

Figure 5: Radiation Pattern

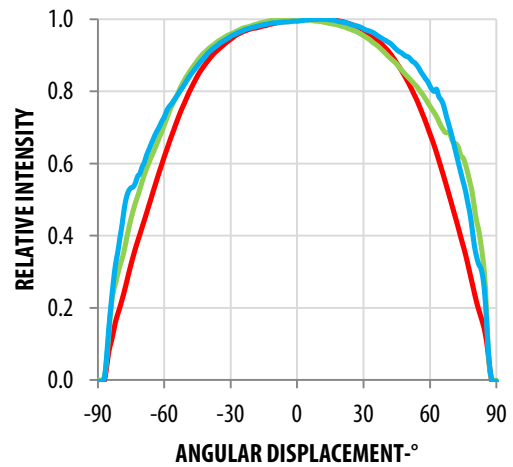

Figure 6: Dominant Wavelength Shift vs. Forward Current

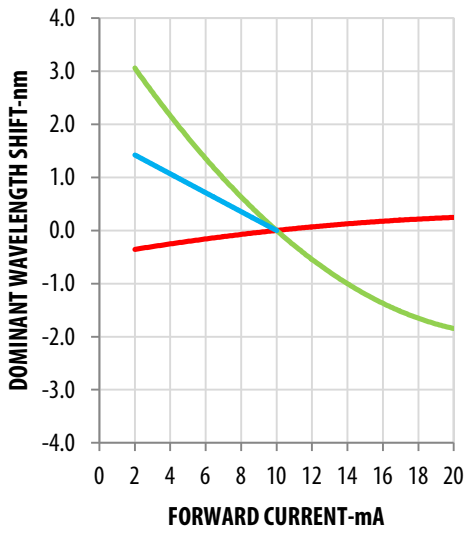

Figure 7: Relative Intensity vs. Temperature

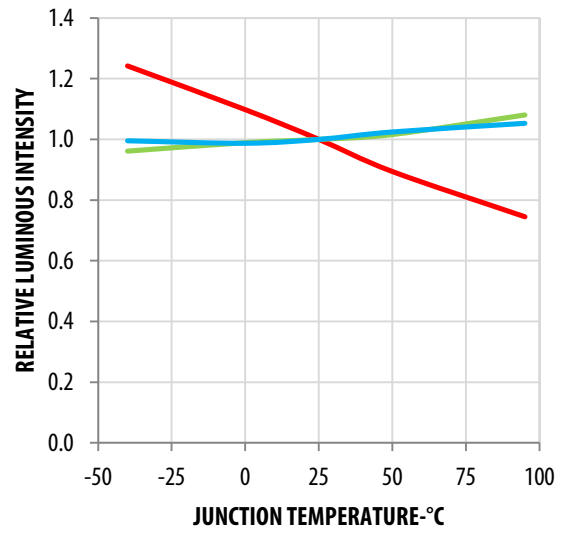

Figure 8: Dominant Wavelength Shift vs. Temperature

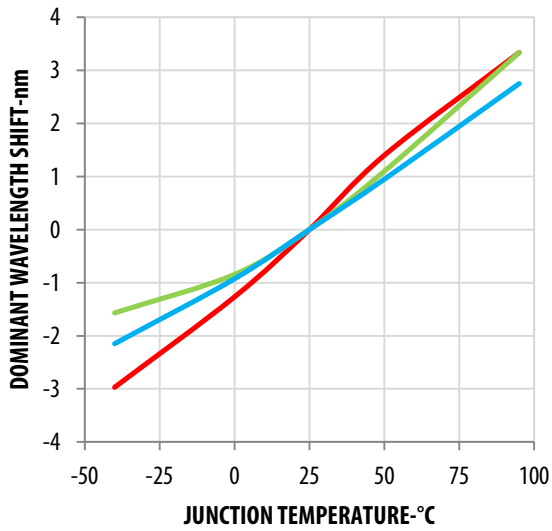

Figure 9: Forward Voltage Shift vs. Temperature

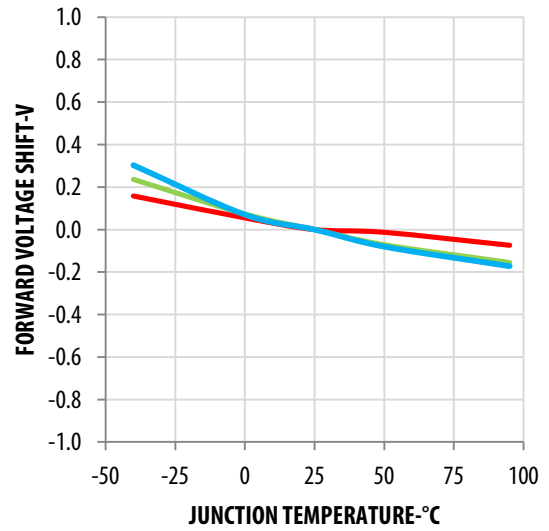

Figure 10: Derating Curve (Single Chip Lit Up)

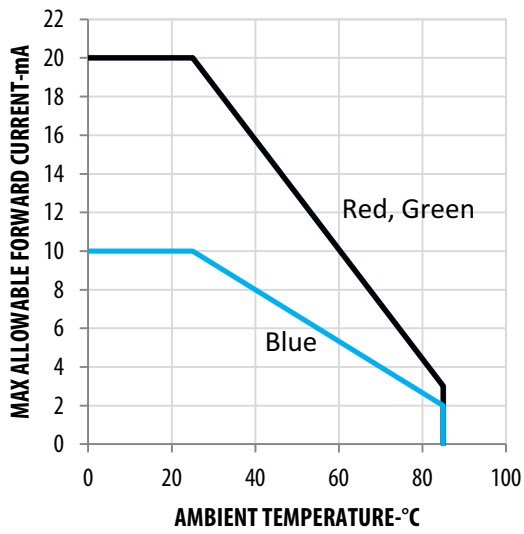

Figure 11: Derating Curve (All Chips Lit Up)

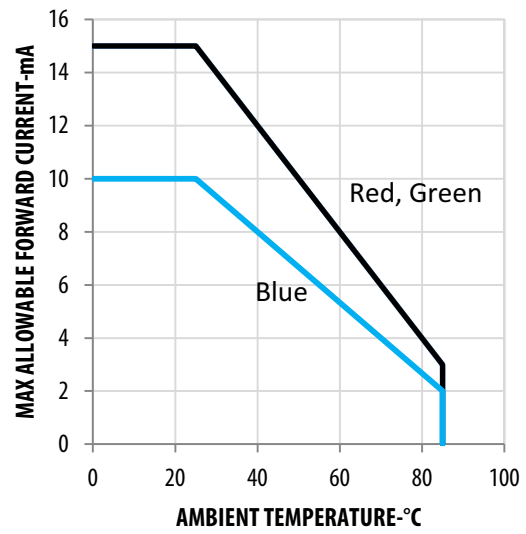

Figure 12: Recommended Solder Pad (Units: mm)

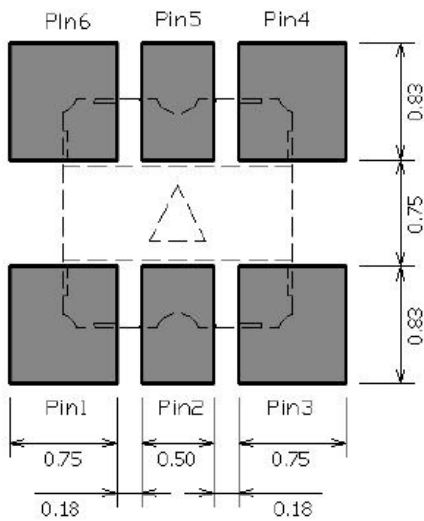

Figure 13: Reel Orientation

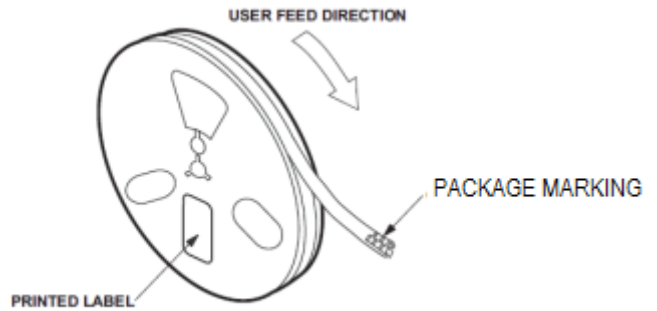
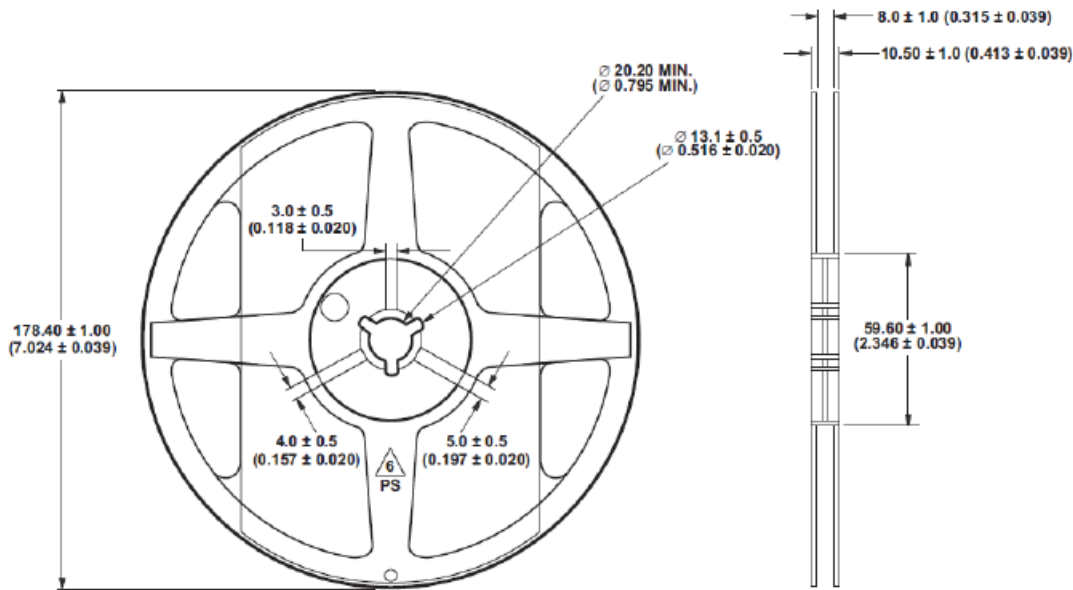
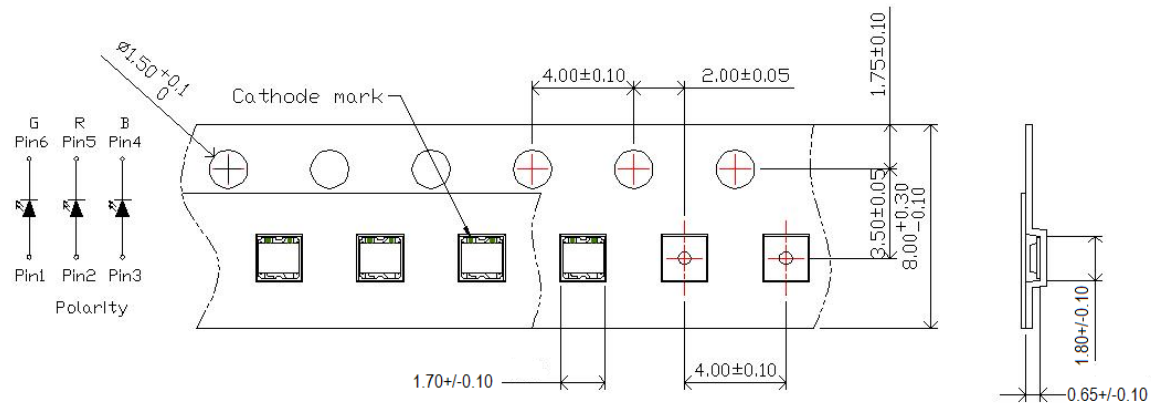

Figure 14: Reel Dimensions (Units: mm [inches])



Note:
All dimensions in millimeters (inches).

Figure 15: Carrier Tape Dimensions (Units: mm)



Precautionary Notes

Soldering

- Do not perform reflow soldering more than twice. Observe necessary precautions of handling moisture sensitive device as stated in the following section.
- Do not apply any pressure or force on the LED during reflow and after reflow when the LED is still hot.
- Use reflow soldering to solder the LED. If unavoidable (such as rework), use hand soldering strictly controlled to the following conditions:
 - Soldering iron tip temperature = 310°C maximum
 - Soldering duration = 2 seconds maximum
 - Number of cycles = 1 only
 - Power of soldering iron = 50W maximum
- Do not touch the LED package body with the soldering iron except for the soldering terminals because it might cause damage to the LED.
- Confirm beforehand whether the functionality and performance of the LED is affected by hand soldering.

Figure 16: Recommended Lead-Free Reflow Soldering Profile

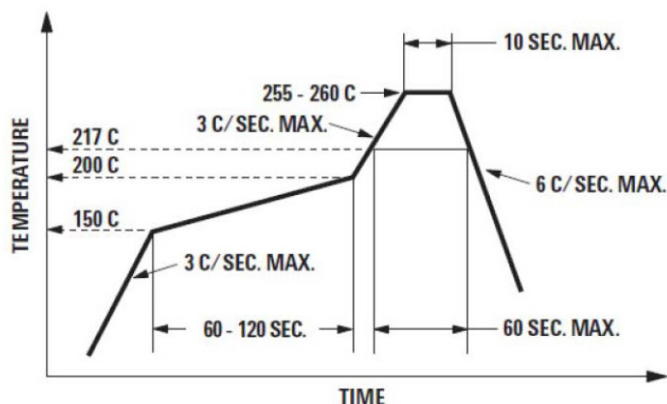

Handling of Moisture-Sensitive Devices

This product has a Moisture Sensitive Level 2a rating per JEDEC J-STD-020. Refer to Broadcom Application Note AN5305, *Handling of Moisture Sensitive Surface Mount Devices*, for additional details and a review of proper handling procedures.

- **Before use:**
 - An unopened moisture barrier bag (MBB) can be stored at < 40°C/90% RH for 12 months. If the actual shelf life has exceeded 12 months and the humidity indicator card (HIC) indicates that baking is not required, it is safe to reflow the LEDs per the original MSL rating.
 - Do not open the MBB prior to assembly (for example, for IQC). If unavoidable, properly reseal the MBB with fresh desiccant and HIC. The exposed duration must be taken in as floor life.
- **Control after opening the MBB:**
 - Read the HIC immediately upon opening the MBB.
 - Keep the LEDs at < 30°C/60% RH at all times, and complete all high-temperature-related processes, including soldering, curing, or rework, within 672 hours.
- **Control for unfinished reel:**

Store unused LEDs in a sealed MBB with desiccant or desiccator at < 5% RH.
- **Control of assembled boards:**

If the PCB soldered with the LEDs is to be subjected to other high-temperature processes, store the PCB in a sealed MBB with desiccant or desiccator at < 5% RH to ensure that all LEDs have not exceeded their floor life of 672 hours.
- **Baking is required if the following conditions exist:**
 - The HIC indicator indicates a change in color for 10% and 5% as stated on the HIC.
 - The LEDs are exposed to conditions of > 30°C/60% RH at any time.
 - The LEDs' floor life exceeded 672 hours.

The recommended baking condition is: 60°C ±5°C for 20 hours.

Baking should only be done once.

Application Precautions

- The drive current of the LED must not exceed the maximum allowable limit across temperature as stated in the data sheet. Constant current driving is recommended to ensure consistent performance.
- Circuit design must cater to the whole range of forward voltage (V_F) of the LEDs to ensure the intended drive current can always be achieved.

- LEDs exhibit slightly different characteristics at different drive currents that might result in larger performance variations (that is, intensity, wavelength, and forward voltage). Set the application current as close as possible to the test current to minimize these variations.
- The LED is not intended for reverse bias. Use other appropriate components for such purposes. When driving the LED in matrix form, ensure that the reverse bias voltage does not exceed the allowable limit of the LED.
- Avoid rapid change in ambient temperature, especially in high-humidity environments, because this will cause condensation on the LED.
- If the LED is intended to be used in harsh or outdoor environments, protect the LED against damages caused by rain water, water, dust, oil, corrosive gases, external mechanical stress, and so on.

Eye Safety and Precautions

LEDs may pose optical hazards when in operation. Do not look directly at operating LEDs as it may be harmful to the eyes. For safety reasons, use appropriate shielding or personal protection equipment.

Disclaimer

Broadcom's products are not specifically designed, manufactured, or authorized for sale as parts, components, or assemblies for the planning, construction, maintenance, or direct operation of a nuclear facility or for use in medical devices or applications. The customer is solely responsible, and waives all rights to make claims against Broadcom or its suppliers, for all loss, damage, expense, or liability in connection with such use.

Broadcom, the pulse logo, Connecting everything, Avago Technologies, Avago, and the A logo are among the trademarks of Broadcom and/or its affiliates in the United States, certain other countries and/or the EU.

Copyright © 2017–2021 Broadcom. All Rights Reserved.

The term "Broadcom" refers to Broadcom Inc. and/or its subsidiaries. For more information, please visit www.broadcom.com.

Broadcom reserves the right to make changes without further notice to any products or data herein to improve reliability, function, or design. Information furnished by Broadcom is believed to be accurate and reliable. However, Broadcom does not assume any liability arising out of the application or use of this information, nor the application or use of any product or circuit described herein, neither does it convey any license under its patent rights nor the rights of others.



Lead (Pb) Free
RoHS Compliant