

HLMP-KA45

T-1 (3-mm) High Intensity InGaN Lamp

Description

This Broadcom® blue LED is designed in an industry-standard T-1 package with clear and nondiffused optics. This lamp is ideal for use as indicators and for general-purpose lighting.

Applications

- Status indicators
- Small message panel
- Running and decorative lights for commercial use
- Backlighting
- Consumer audio

Features

- Popular T1 diameter package
- General-purpose leads
- Reliable and rugged
- Binned for color and intensity
- InGaN blue dice

CAUTION! Devices are Class 1C HBM ESD sensitive per JEDEC Standard. Observe appropriate precautions during handling and processing. For additional details, refer to Application Note AN-1142.

Package Dimensions

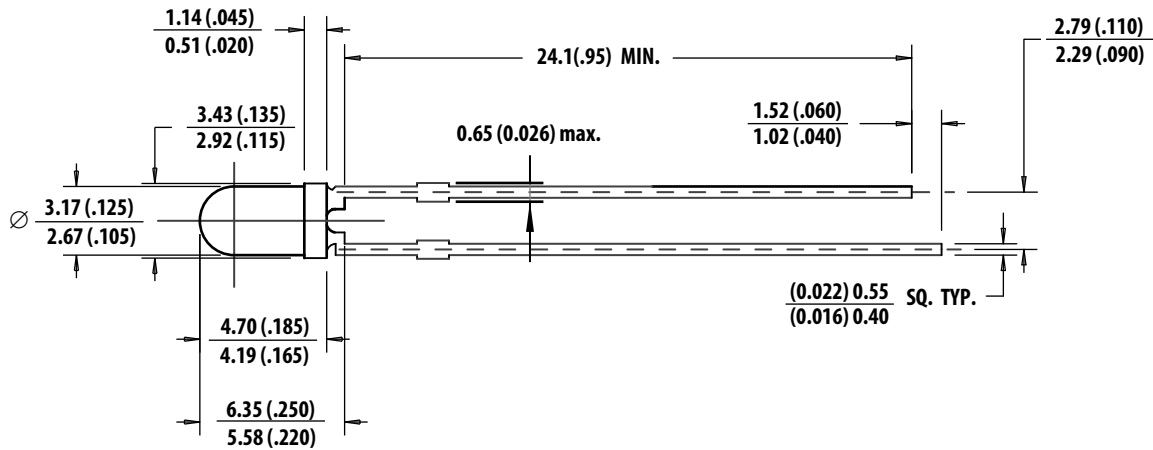

NOTE:

1. All dimensions are in mm (in.).
2. An epoxy meniscus may extend about 1 mm (0.040 in.) down the leads.
3. For PCB hole recommendations, see [Precautions](#).

Device Selection Guide

Part Number	Color and Dominant Wavelength λ_d^a (nm) Typ.	Luminous Intensity I_v (mcd) at 20 mA Min. ^{b, c}	Luminous Intensity I_v (mcd) at 20 mA Max. ^{b, c}
HLMP-KA45-E0000	Blue 470	85	—
HLMP-KA45-J0000	Blue 470	240	—

- a. The dominant wavelength, λ_d is derived from the CIE Chromaticity Diagram and represents the color of the lamp.
- b. The luminous intensity is measured on the mechanical axis of the lamp package.
- c. 2.The optical axis is closely aligned with the package mechanical axis.

Absolute Maximum Ratings at $T_A = 25^\circ\text{C}$

Parameter	HLMP-KA45 (Blue)	Units
DC Forward Current ^a	30	mA
Peak Pulsed Forward Current ^b	100	mA
Power Dissipation	116	mW
LED Junction Temperature	115	$^\circ\text{C}$
Operating Temperature Range	-35 to +85	$^\circ\text{C}$
Storage Temperature Range	-35 to +85	$^\circ\text{C}$

- a. Derate linearly as shown in [Figure 4](#).
- b. Duty factor = 10%, frequency = 1 kHz.

Electrical /Optical Characteristics at $T_A = 25^\circ\text{C}$

Parameter	Symbol	Min.	Typ.	Max.	Units	Test Conditions
Forward Voltage	V_F	2.8	3.2	3.8	V	$I_F = 20\text{ mA}$
Capacitance	C	—	40	—	pF	$V_F = 0, f = 1\text{ MHz}$
Thermal Resistance	$R\theta_{J-PIN}$	—	465	—	$^\circ\text{C/W}$	LED Junction-to-Cathode Lead
Viewing Angle ^a	$2\theta_{1/2}$	—	50	—	deg	
Dominant Wavelength ^b	λ_d	—	470	—	nm	$I_F = 20\text{ mA}$
Peak Wavelength	λ_P	—	464	—	nm	Peak of Wavelength of Spectral Distribution at $I_F = 20\text{ mA}$
Spectral Halfwidth	$\Delta\lambda_{1/2}$	—	24	—	nm	Wavelength Width at Spectral Distribution $\frac{1}{2}$ Power Point at $I_F = 20\text{ mA}$

a. $2\theta_{1/2}$ is the off-axis angle where the luminous intensity is 1/2 the on axis intensity.

b. The dominant wavelength, λ_d , is derived from the Chromaticity Diagram and represents the color of the lamp.

Part Numbering System

H L M P - X₁ X₂ X₃ X₄ - X₅ X₆ X₇ X₈ X₉

Code	Description	Option	
X ₁	Package Type	K	T-1
X ₂	Color	A	Blue
X ₃ X ₄	Viewing Angle	45	55°
X ₅	Minimum Intensity Bin	See Intensity Bin Limits	
X ₆	Maximum Intensity Bin	0	Open binning (no max. I_V bin limit)
X ₇	Color Bin Selection	0	Full color bin range
X ₈ X ₉	Packaging Option	00	Bulk

Bin Information

Intensity Bin Limits

Bin	Intensity (mcd) at 20 mA	
	Min.	Max.
E	85	110
F	110	140
G	140	180
H	180	240
J	240	310
K	310	400
L	400	520
M	520	680
N	680	880
P	880	1150
Q	1150	1500
R	1500	1900
S	1900	2500
T	2500	3200

Tolerance for each bin limit is $\pm 15\%$.

Color Bin Limits

Color	Cat Number	Lambda (nm)	
		Min.	Max.
Blue	1	460.0	464.0
	2	464.0	468.0
	3	468.0	472.0
	4	472.0	476.0
	5	476.0	480.0

Tolerance for each bin limit is ± 0.5 nm.

Mechanical Option Matrix

Mechanical Option Code	Definition
00	Bulk Packaging, minimum increment 500 pieces/bag

NOTE: All categories are established for classification of products. Products may not be available in all categories. For further clarification and information, contact your local Broadcom representative.

Figure 1: Relative Intensity vs. Wavelength

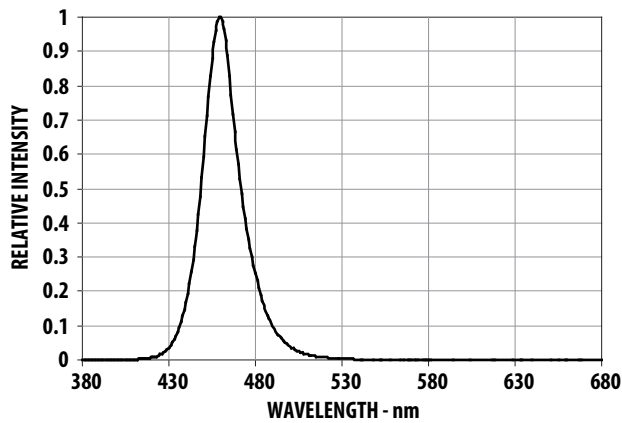

Figure 2: Forward Current vs. Forward Voltage

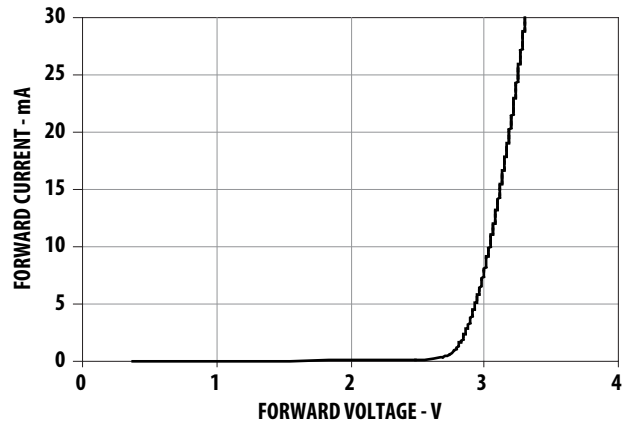

Figure 3: Relative Luminous Intensity vs. Forward Current

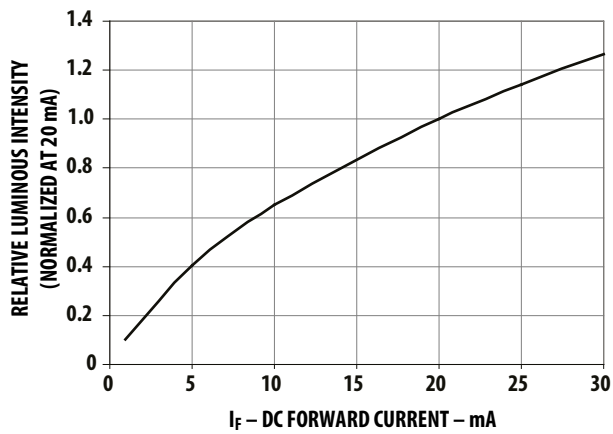

Figure 4: Maximum Forward Current vs. Ambient Temperature Based on $T_{jmax} = 115^{\circ}C$

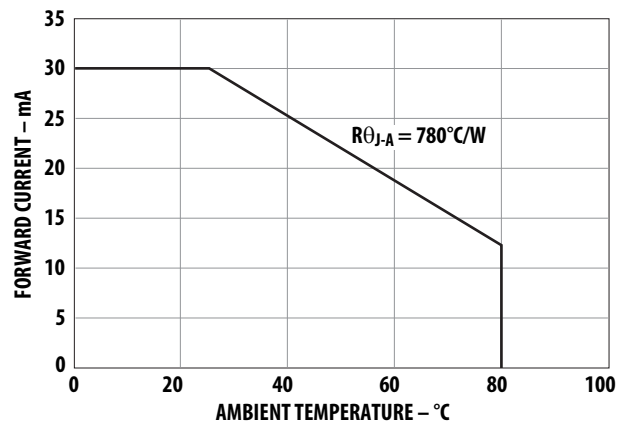
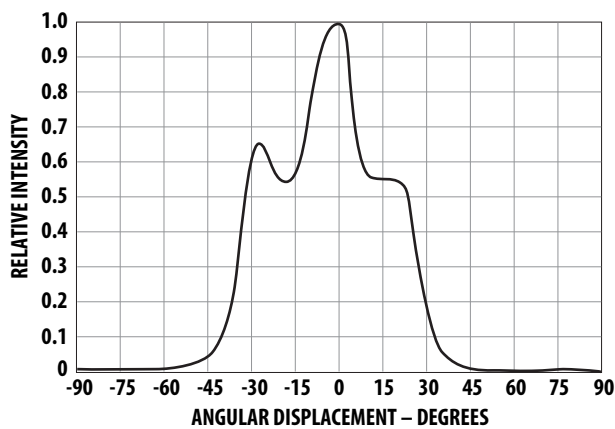

Figure 5: Radiation Pattern



Precautions

Lead Forming

- The leads of an LED lamp may be preformed or cut to length prior to insertion and soldering into PC board.
- If lead forming is required before soldering, take care to avoid any excessive mechanical stress induced to LED package. Otherwise, cut the leads of LED to length after soldering process at room temperature. The solder joint formed will absorb the mechanical stress of the lead cutting from traveling to the LED chip die attach and wirebond.
- Make the tooling to precisely form and cut the leads to length rather than rely upon hand operation.

Soldering Conditions

- Take care during the PCB assembly and soldering process to prevent damage to LED component.
- Ensure that the closest LED to solder on board is 1.59 mm below the body (encapsulant epoxy) for those parts without standoff.
- The soldering conditions follow.

	Wave Soldering	Manual Solder Dipping
Pre-heat Temperature	105°C max.	—
Pre-heat Time	60s max.	—
Peak Temperature	250°C max.	260°C max.
Dwell Time	3s max.	5s max.

- Set and maintain the wave soldering parameter according to recommended temperature and dwell time in the solder wave. Periodically check on the soldering profile to ensure the soldering profile used always conforms to recommended soldering condition.
- If necessary, use the fixture to hold the LED component in proper orientation with respect to the PCB during the soldering process.
- Use proper handling to avoid excessive thermal stresses to LED components when heated. Therefore, the soldered PCB must be allowed to cool to room temperature, 25°C, before handling.
- Pay special attention to board fabrication, solder masking, surface plating, and lead holes' size and component orientation to assure solderability.
- The recommended PC board plated through hole sizes for LED component leads follow.

	LED Component Lead Size	Diagonal	Plated Through-Hole Diameter
Lead size (typ.)	0.45 × 0.45 mm (0.018 × 0.018 in.)	0.636 mm (0.025 in.)	0.98 to 1.08 mm (0.039 to 0.043 in.)
Dambar shearoff area (max.)	0.65 mm (0.026 in.)	0.919 mm (0.036 in.)	
Lead size (typ.)	0.50 × 0.50 mm (0.020 × 0.020 in.)	0.707 mm (0.028 in.)	1.05 to 1.15 mm (0.041 to 0.045 in.)
Dambar shearoff area (max.)	0.70 mm (0.028 in.)	0.99 mm (0.039 in.)	

NOTE: Refer to application note AN1027 for more information on soldering LED components.

Figure 6: Recommended Wave Soldering Profile

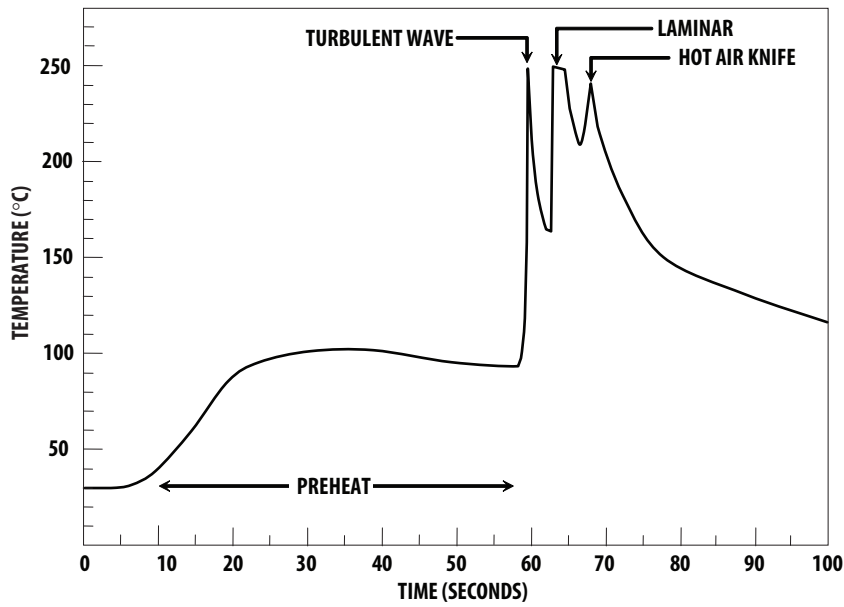

Recommended solder:
 Sn63 (Leaded solder alloy)
 SAC305 (Lead-free solder alloy)

Flux: Rosin flux

Solder bath temperature:
 245 °C ± 5 °C (maximum peak temperature = 250 °C)

Dwell time: 1.5 sec – 3.0 sec (maximum = 3 sec)

Note: Allow for board to be sufficiently cooled to room temperature before you exert mechanical force.

Packing Label

(i) Mother Label (Available on packaging box of ammo pack and shipping box)

	
(1P) Item: Part Number 	STANDARD LABEL LS0002 RoHS Compliant e3 max temp 250C
(1T) Lot: Lot Number 	(Q) QTY: Quantity 
LPN: 	CAT: Intensity Bin 
(9D)MFG Date: Manufacturing Date 	BIN: Color Bin
<hr/> (P) Customer Item: 	
(V) Vendor ID: 	(9D) Date Code: Date Code 
DeptID: 	Made In: Country of Origin 

(ii) Baby Label (Only available on bulk packaging)

	
Lamps Baby Label	
RoHS Compliant e3 max temp 250C	
(1P) PART #: Part Number 	
(1T) LOT #: Lot Number 	
(9D)MFG DATE: Manufacturing Date 	QUANTITY: Packing Quantity 
C/O: Country of Origin	
Customer P/N: 	CAT: Intensity Bin 
Supplier Code: 	BIN: Color Bin 
	DATECODE: Date Code 

Broadcom, the pulse logo, Connecting everything, Avago Technologies, Avago, and the A logo are among the trademarks of Broadcom and/or its affiliates in the United States, certain other countries, and/or the EU.

Copyright © 2015–2021 Broadcom. All Rights Reserved.

The term “Broadcom” refers to Broadcom Inc. and/or its subsidiaries. For more information, please visit www.broadcom.com.

Broadcom reserves the right to make changes without further notice to any products or data herein to improve reliability, function, or design. Information furnished by Broadcom is believed to be accurate and reliable. However, Broadcom does not assume any liability arising out of the application or use of this information, nor the application or use of any product or circuit described herein, neither does it convey any license under its patent rights nor the rights of others.

