

HCPL-354

AC Input Phototransistor Optocoupler SMD Mini-Flat Type

Description

The Broadcom® HCPL-354 contains a phototransistor, optically coupled to two LEDs connected inverse parallel. It can operate directly by AC input current. It is packaged in a 4-pin mini-flat SMD package with a 2.0-mm profile. The small dimension of this product allows significant space savings. The package volume is 30% smaller than that of conventional DIP type. Input-output isolation voltage is 3750 V_{rms}. Response time, t_r , is typically 4 μ s and minimum CTR is 20% at input current of ± 1 mA.

Functional Diagram

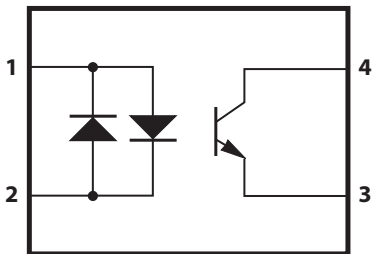

1. ANODE, CATHODE 3. EMITTER
2. CATHODE, ANODE 4. COLLECTOR

Features

- AC input response
- Current transfer ratio
(CTR: min. 20% at $I_F = \pm 1$ mA, $V_{CE} = 5$ V)
- Isolation voltage between input and output
($V_{iso} = 3,750$ V_{rms})
- Subminiature type
(The volume is smaller than that of conventional DIP type by as far as 30%)
- Mini-flat package
- 2.0 mm profile
- UL approved
- CSA approved
- IEC/EN 60747-5-5 approved
- Options available:
 - IEC/EN 60747-5-5 approvals (060)

Applications

- Detecting or monitoring AC signals
- Programmable controllers
- AC/DC-input modules
- AC line/digital logic isolation

CAUTION! Take normal static precautions in handling and assembly of this component to prevent damage and/or degradation that might be induced by electrostatic discharge (ESD). The components featured in this data sheet are not to be used in military or aerospace applications or environments. The components are not AEC-Q100 qualified and not recommended for automotive applications.

Ordering Information

HCPL-354 is UL Recognized with 3750 V_{rms} for 1 minute per UL1577 and is approved under CSA Component Acceptance Notice #5, File CA 88324.

Part Number	RoHS Compliant Option		Package	Surface Mount	Gull Wing	Tape and Reel	IEC/EN 60747-5-5	Quantity
	Rank '0' 20%<CTR<400%	'Rank 'A' 50%<CTR<150%						
HCPL-354	-000E	-00AE	SO-4	X		X		3000 pieces per reel
	-060E	-06AE	SO-4	X		X	X	3000 pieces per reel

To order, choose a part number from the part number column and combine with the desired option from the option column to form an order entry.

Example 1:

HCPL-354-00AE to order product of Miniflat-4 AC Surface Mount package in Tape and Reel packaging with 50%<CTR<150% and RoHS compliant.

Example 2:

HCPL-354-060E to order product of Miniflat-4 AC Surface Mount package in Tape and Reel pack- aging with 20%<CTR<400%, IEC/EN 60747-5-5 Safety Approval and RoHS compliant.

Option data sheets are available. Contact your Broadcom sales representative or authorized distributor for information.

Package Outline Drawing

HCPL-354-000E

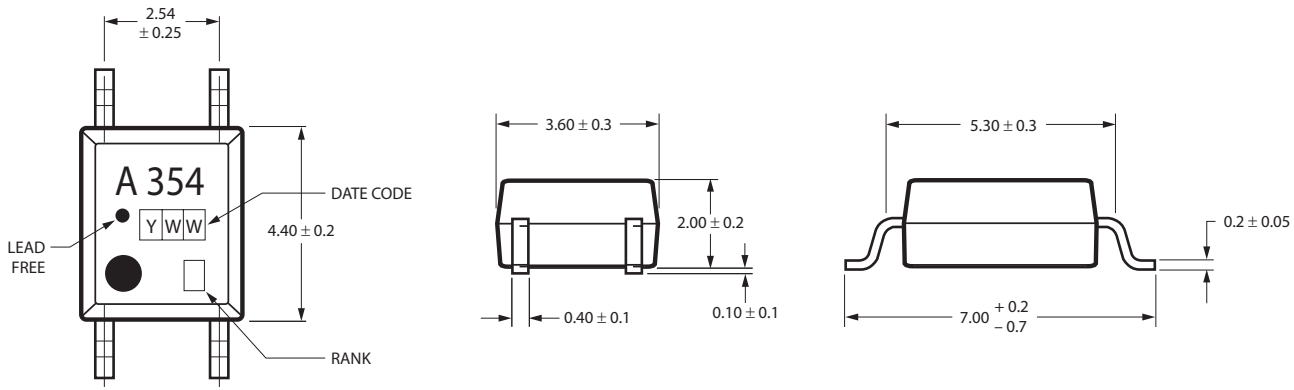

DIMENSIONS IN MILLIMETERS.

HCPL-354-060E

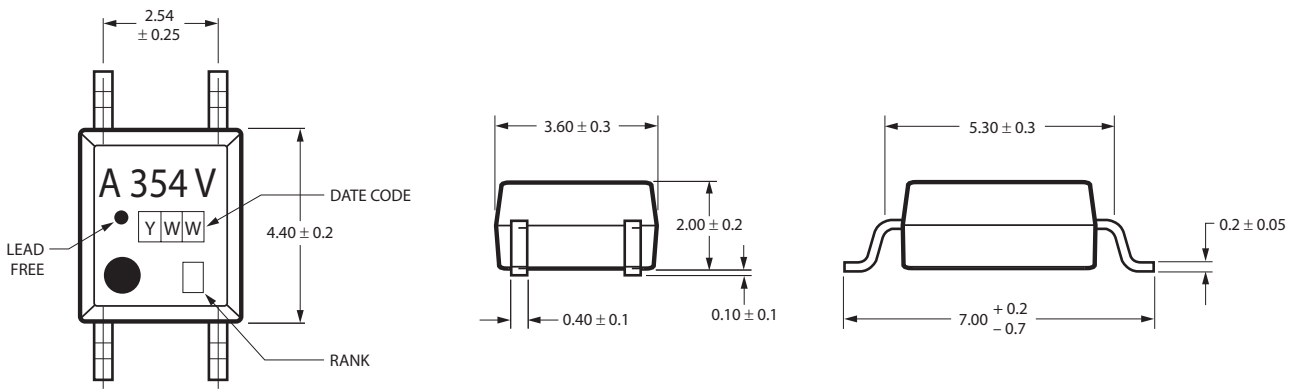

DIMENSIONS IN MILLIMETERS.

Solder Reflow Profile

Recommended reflow condition as per JEDEC Standard, J-STD-020 (latest revision). Non-halide flux should be used.

Absolute Maximum Ratings

Parameters	Symbol	Min.	Max.	Units
Storage Temperature	T_S	-55	150	°C
Ambient Operating Temperature	T_A	-55	100	°C
Lead Solder Temperature for 10s (1.6 mm below seating plane)	T_{sol}	—	260	°C
Average Forward Current	I_F	—	±50	mA
Input Power Dissipation	P_I	—	70	mW
Collector Current	I_C	—	50	mA
Collector-Emitter Voltage	V_{CEO}	—	35	V
Emitter-Collector Voltage	V_{ECO}	—	6	V
Collector Power Dissipation	P_C	—	150	mW
Total Power Dissipation	P_{tot}	—	170	mW
Isolation Voltage (AC for 1 minute, RH = 40 ~ 60%) ^a	V_{iso}	—	3750	V_{rms}

a. Isolation voltage shall be measured using the following method:

- (a) Short between anode and cathode on the primary side and between collector and emitter on the secondary side.
- (b) The isolation voltage tester with zero-cross circuit is used.
- (c) The waveform of applied voltage is a sine wave.

Electrical Specifications ($T_A = 25^\circ\text{C}$)

Parameter	Symbol	Min.	Typ.	Max.	Units	Test Conditions
Forward Voltage	V_F	—	1.2	1.4	V	$I_F = \pm 20 \text{ mA}$
Terminal Capacitance	C_t	—	30	250	pF	$V = 0, f = 1 \text{ kHz}$
Collector Dark Current	I_{CEO}	—	-	100	nA	$V_{CE} = 20\text{V}, I_F = 0$
Collector-Emitter Breakdown Voltage	BV_{CEO}	35	—	—	V	$I_C = 0.1 \text{ mA}, I_F = 0$
Emitter-Collector Breakdown Voltage	BV_{ECO}	6	—	—	V	$I_E = 10 \mu\text{A}, I_F = 0$
Collector Current	I_C	0.2	—	4	mA	$I_F = \pm 1 \text{ mA}$
Current Transfer Ratio ^a	CTR	20	—	400	%	$V_{CE} = 5\text{V}$
Collector-Emitter Saturation Voltage	$V_{CE(sat)}$	—	0.1	0.2	V	$I_F = \pm 20 \text{ mA}, I_C = 1 \text{ mA}$
Isolation Resistance	R_{iso}	5×10^{10}	1×10^{11}	—	Ω	DC 500V, 40 ~ 60% RH
Floating Capacitance	C_f	—	0.6	1	pF	$V = 0, f = 1 \text{ MHz}$
Response Time (Rise)	t_r	—	4	18	μs	$V_{CE} = 2\text{V}, I_C = 2 \text{ mA}$
Response Time (Fall)	t_f	—	3	18	μs	$R_L = 100\Omega$

a. $CTR = (I_C / I_F) \times 100\%$.

Rank Mark	CTR (%)	Conditions
A	50 ~ 150	$I_F = \pm 1 \text{ mA}, V_{CE} = 5\text{V}, T_A = 25^\circ\text{C}$
No Mark	20 ~ 400	

Figure 1: Forward Current vs. Ambient Temperature

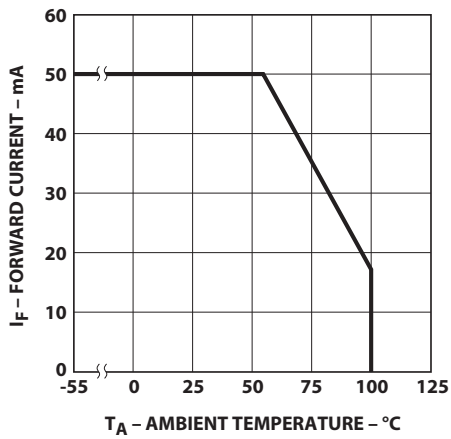

Figure 2: Collector Power Dissipation vs. Ambient Temperature

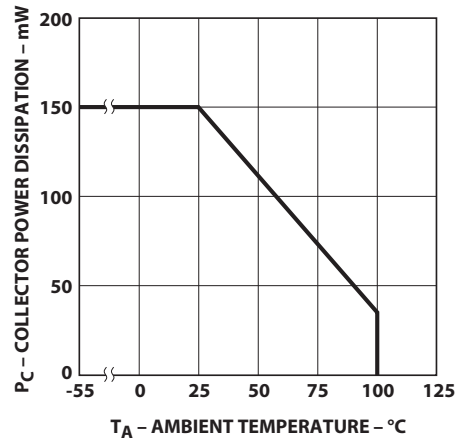

Figure 3: Collector-Emitter Saturation Voltage vs. Forward Current

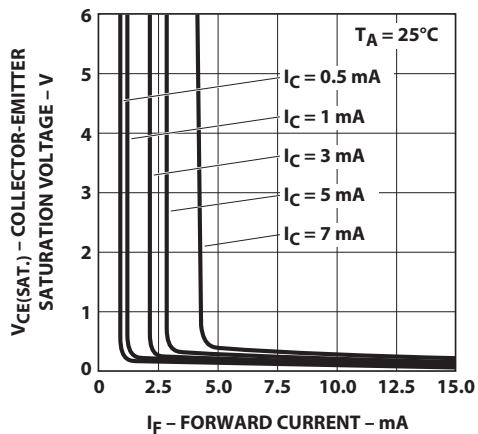

Figure 4: Forward Current vs. Forward Voltage

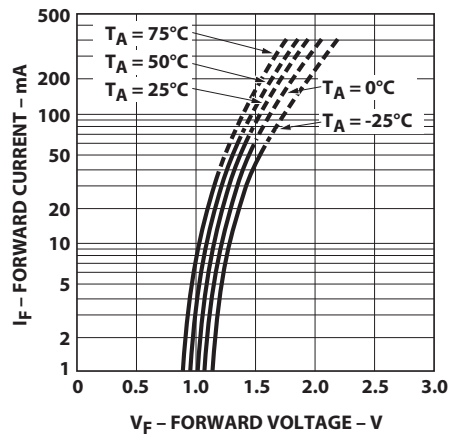

Figure 5: Current Transfer Ratio vs. Forward Current

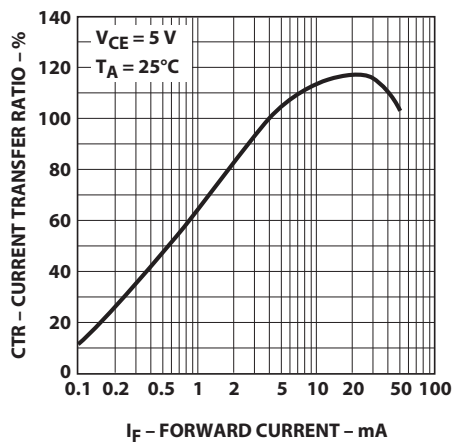

Figure 6: Collector Current vs. Collector-Emitter Voltage

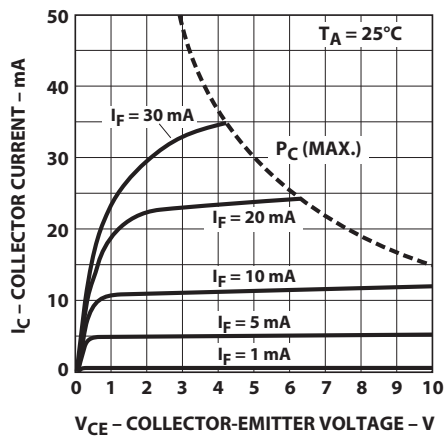

Figure 7: Relative Current Transfer Ratio vs. Ambient Temperature

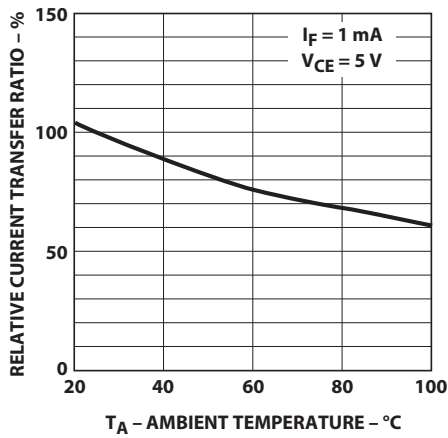

Figure 8: Collector-Emitter Saturation Voltage vs. Ambient Temperature

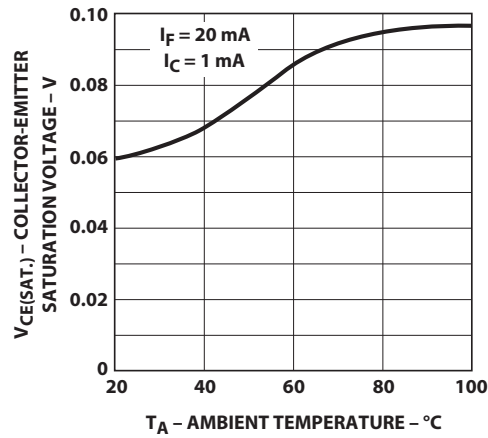

Figure 9: Collector Dark Current vs. Ambient Temperature

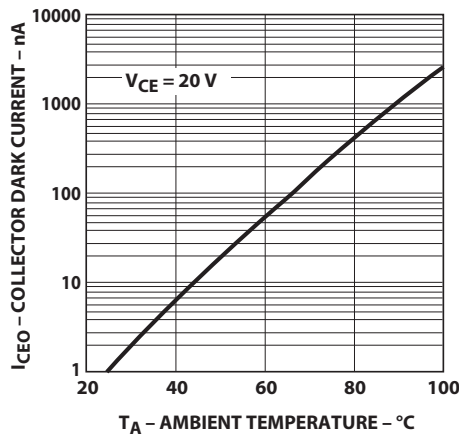

Figure 10: Response Time vs. Load Resistance

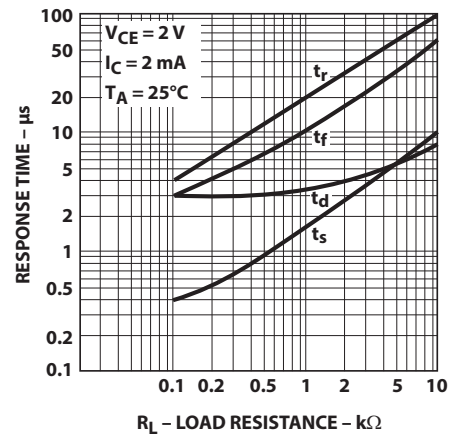

Figure 11: Frequency Response

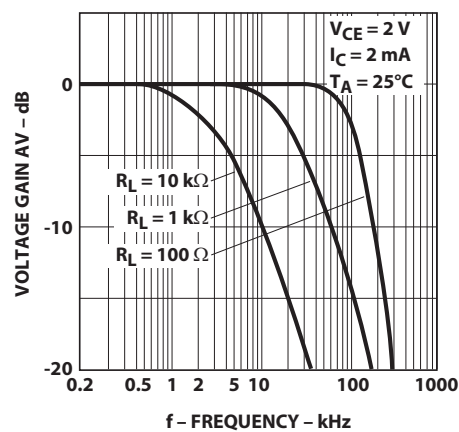

Figure 12: Test Circuit for Response Time

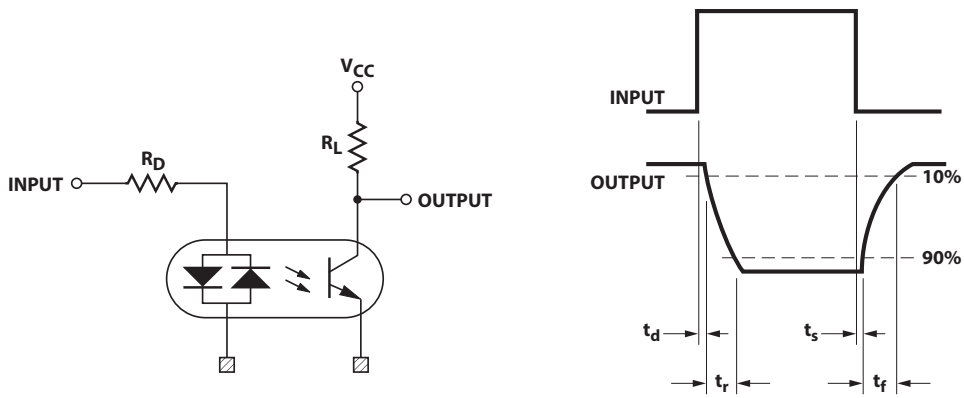
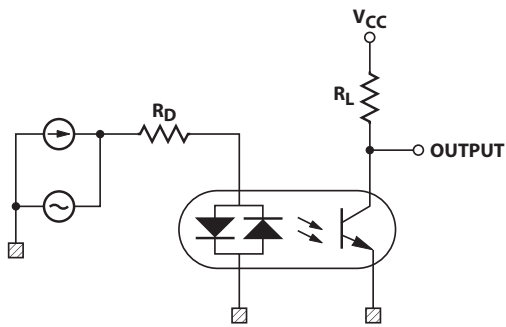

Figure 13: Test Circuit for Frequency Response



Copyright © 2007–2024 Broadcom. All Rights Reserved. The term “Broadcom” refers to Broadcom Inc. and/or its subsidiaries. For more information, go to www.broadcom.com. All trademarks, trade names, service marks, and logos referenced herein belong to their respective companies.

Broadcom reserves the right to make changes without further notice to any products or data herein to improve reliability, function, or design. Information furnished by Broadcom is believed to be accurate and reliable. However, Broadcom does not assume any liability arising out of the application or use of this information, nor the application or use of any product or circuit described herein, neither does it convey any license under its patent rights nor the rights of others.

