

CSMW-Lx00-AxxxE

0.5W 2835 DFN2 Surface-Mount LED

Description

The Broadcom[®] CSMW-Lx00 surface-mount LEDs use AlInGaP chip technology with superior package design to enable them to produce higher light output with better flux performance. They can be driven at high current and are able to dissipate heat more efficiently resulting in better performance with higher reliability.

These LEDs operate under a wide range of environmental conditions, making it ideal for various applications.

To facilitate easy pick and place assembly, the LEDs are packed in tape and reel. Every reel is shipped in single flux and color bin, to provide close uniformity.

Features

- High reliability package with enhanced silicone resin encapsulation
- Available in Amber, Red Orange and Red
- Wide viewing angle at 120°
- Low package profile and large emitting area for better uniformity in linear lighting
- Enhanced corrosion resistance
- Product qualified as per AEC-Q101 guidelines

Applications

- Specialty and architectural lighting
- Gaming/vending machine backlighting
- Industrial backlighting, for example, tower light
- Automotive Exterior Lighting
 - Brake lights/ CHMSL
 - Side marker
 - Truck lighting

CAUTION! This LED is ESD sensitive. Please observe appropriate precautions during handling and processing. Refer to Application Note AN-1142 for additional details.

Package Drawing

Figure 1: Package Drawing

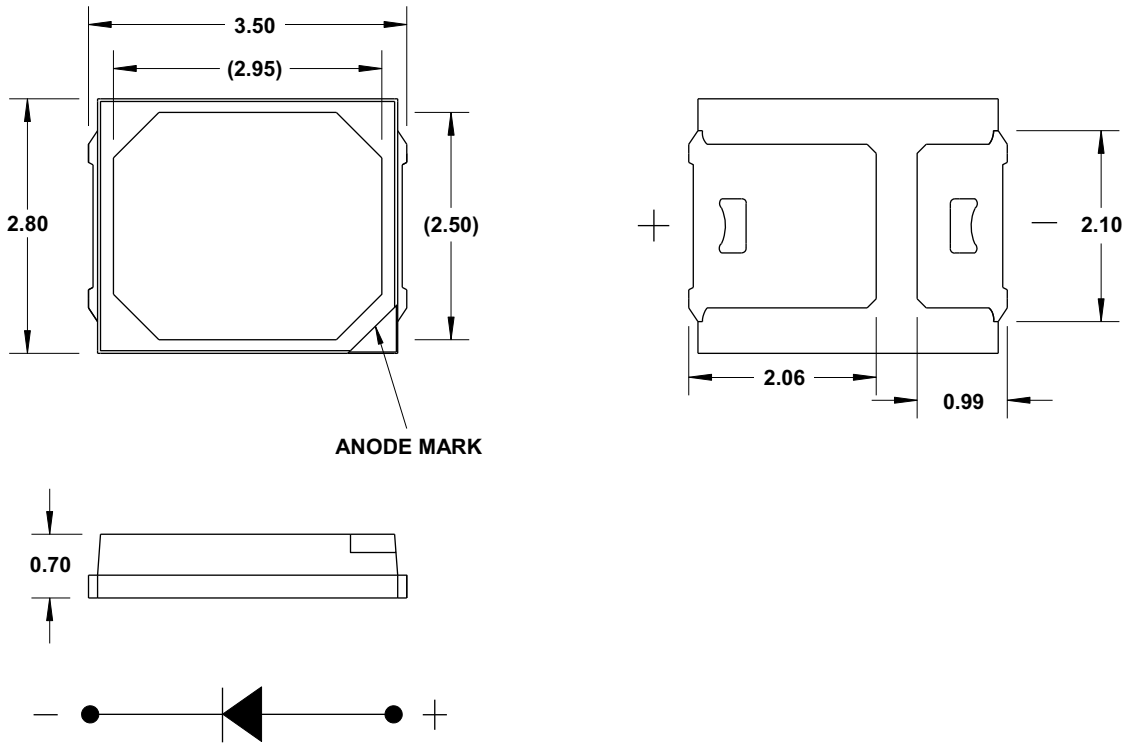

NOTE:

1. All dimensions are in millimeters (mm).
2. Tolerance is ± 0.2 mm unless otherwise specified.
3. Encapsulation = silicone.
4. Terminal finish = silver plating.
5. Dimensions in brackets are for reference only.

Device Selection Guide ($T_J = 25^\circ\text{C}$, $I_F = 150$ mA)

Part Number	Color	Luminous Flux, ϕ_V (lm) ^{a, b}			Luminous Intensity (cd) ^c
		Min.	Typ.	Max.	Typ.
CSMW-LA00-AVX0E	Amber	29.0	32.4	38.0	10.5
CSMW-LH00-AUW0E	Red Orange	26.0	30.7	35.0	10.0
CSMW-LR00-ATV0E	Red	23.0	25.0	32.0	8.1

- a. The luminous flux, ϕ_V , is measured at the mechanical axis of the package and it is tested with a single current pulse condition.
- b. Tolerance is $\pm 12\%$.
- c. For reference only.

Absolute Maximum Ratings

Parameter	CSMW-Lx00-AxxxE	Units
DC Forward Current ^a	200	mA
Peak Forward Current ^b	300	mA
Power Dissipation	580	mW
Reverse Voltage	Not designed for reverse bias operation	
LED Junction Temperature	125	°C
Operating Temperature Range	-40 to +100	°C
Storage Temperature Range	-40 to +100	°C

a. Derate linearly as shown in figure 10 and figure 11.

b. Duty factor = 10%, frequency = 1 kHz, $T_A = 25^\circ\text{C}$.

Optical and Electrical Characteristics ($T_J = 25^\circ\text{C}$, $I_F = 150\text{ mA}$)

Parameter	Min.	Typ.	Max.	Units
Viewing Angle, $2\theta_{1/2}$ ^a	—	120	—	Deg
Forward Voltage, V_F ^b				V
Amber	1.8	2.4	2.9	
Red Orange	1.8	2.3	2.9	
Red	1.8	2.1	2.9	
Reverse Current, I_R at $V_R = 5V$ ^c	—	—	10	μA
Dominant Wavelength, λ_d				nm
Amber	584.5	590	597.0	
Red Orange	611	614	620	
Red	620	622	635	
Peak Wavelength, λ_p				nm
Amber	—	592	—	
Red Orange	—	622	—	
Red	—	631	—	
Thermal Resistance, $R_{\theta J-S}$ ^d	—	25	—	°C/W

a. $\theta_{1/2}$ is the off-axis angle where the luminous intensity is half of the peak intensity.

b. Forward voltage tolerance = $\pm 0.1V$.

c. Indicates product final test condition. Long term reverse bias is not recommended

d. Thermal resistance from LED junction to solder point.

Part Numbering System

C S M W - L x₁ 0 0 - A x₂ x₃ x₄ x₅

Code	Description	Option	
x ₁	Color	A	Amber
		H	Red Orange
		R	Red
x ₂	Minimum Flux Bin	Refer to Flux Bin Limits (CAT) table	
x ₃	Maximum Flux Bin		
x ₄	Color Bin	0	Full distribution
x ₅	Test Option	E	Test Current = 150 mA

Part Number Example

CSMW-LA00-AVX0E

x₁ : A Amber
 x₂ : V Minimum flux bin V
 x₃ : X Maximum flux bin X
 x₄ : 0 Full color distribution
 x₅ : E Test current = 150 mA

Bin Information

Flux Bin Limits (CAT)

Bin ID	Luminous Flux ϕ_V (lm)	
	Min.	Max.
T	23	26
U	26	29
V	29	32
W	32	35
X	35	38

Tolerance = $\pm 12\%$.

Forward Voltage Bin Limits (V_F)

Bin ID	Forward Voltage V_F (V)	
	Min.	Max.
H11	1.8	1.9
H12	1.9	2.0
H13	2.0	2.1
H14	2.1	2.2
H15	2.2	2.3
H16	2.3	2.4
H17	2.4	2.5
H18	2.5	2.6
G01	2.6	2.7
G02	2.7	2.8
G03	2.8	2.9

Tolerance = $\pm 0.1V$

Example of bin information on reel and packaging label:

CAT: W Flux bin W
 BIN: 2 Color bin 2
 VF: H15 VF bin H15

Color Bin Limits (BIN)

Amber

Bin ID	Dominant Wavelength (nm)	
	Min.	Max.
2	584.5	587.0
3	587.0	589.5
4	589.5	592.0
5	592.0	594.5
6	594.5	597.0

Red Orange

Bin ID	Dominant Wavelength (nm)	
	Min.	Max.
1	611.0	616.0
2	616.0	620.0

Red

Bin ID	Dominant Wavelength (nm)	
	Min.	Max.
—	620.0	635.0

Tolerance = ± 1.0 nm

Figure 2: Spectral Power Distribution

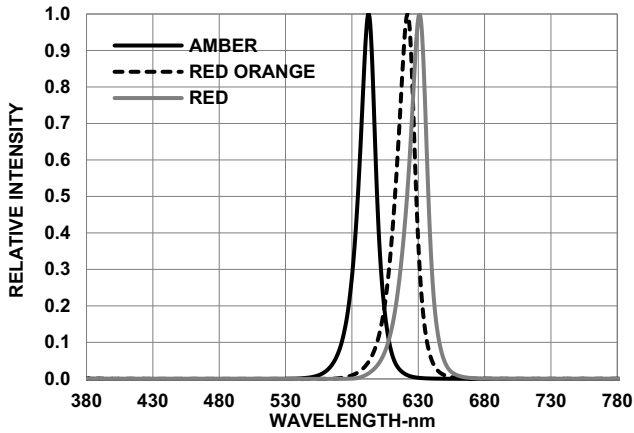

Figure 3: Forward Current vs. Forward Voltage

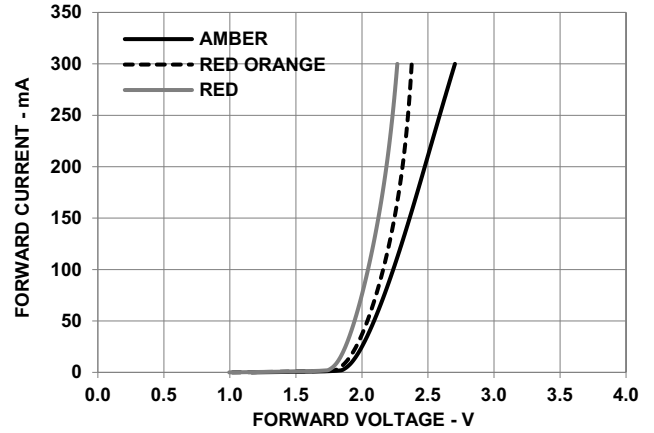

Figure 4: Relative Luminous Flux vs. Mono Pulse Current

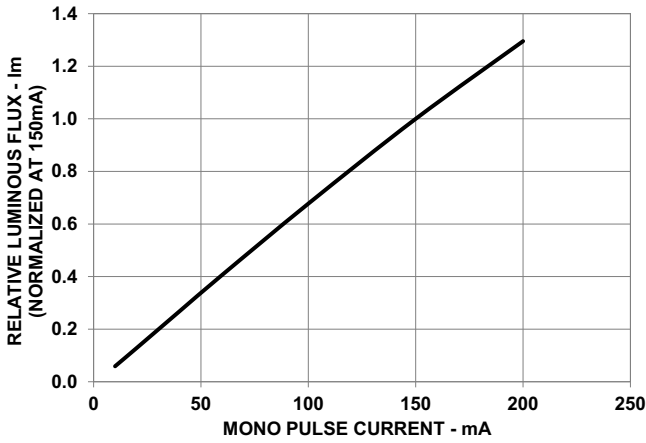

Figure 5: Radiation Pattern

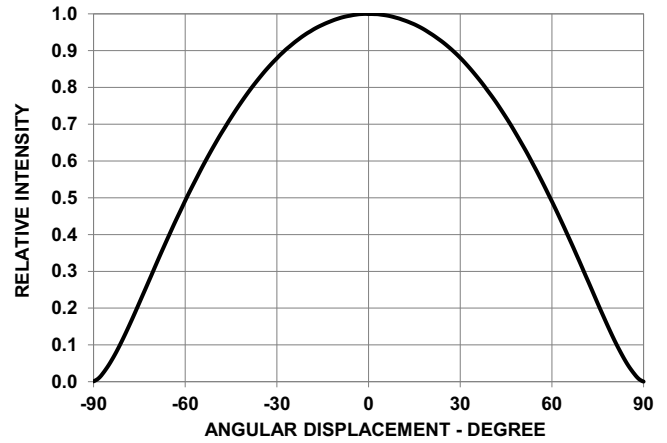

Figure 6: Dominant Wavelength Shift vs. Mono Pulse Current

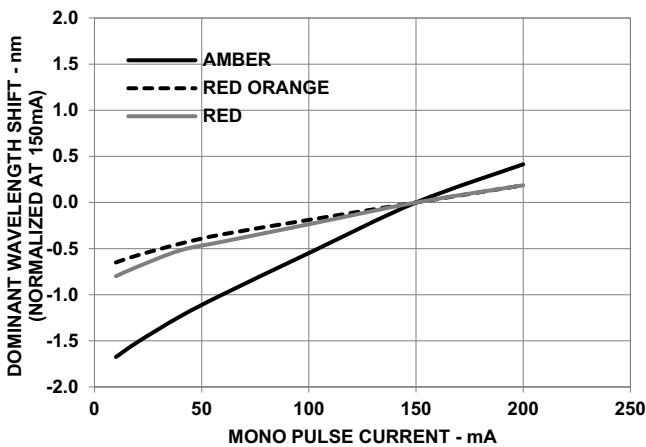

Figure 7: Forward Voltage Shift vs. Junction Temperature

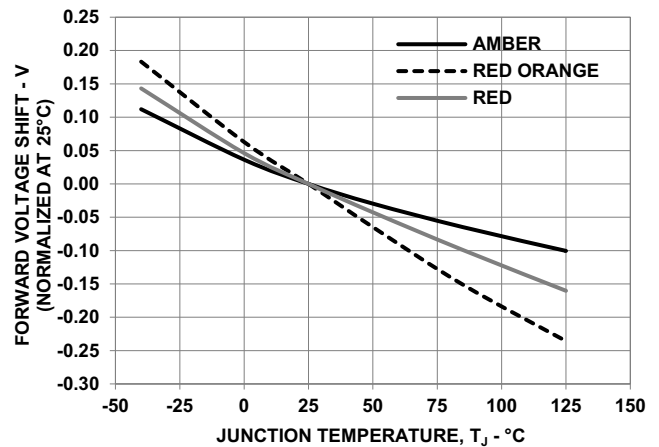

Figure 8: Relative Luminous Flux vs. Junction Temperature

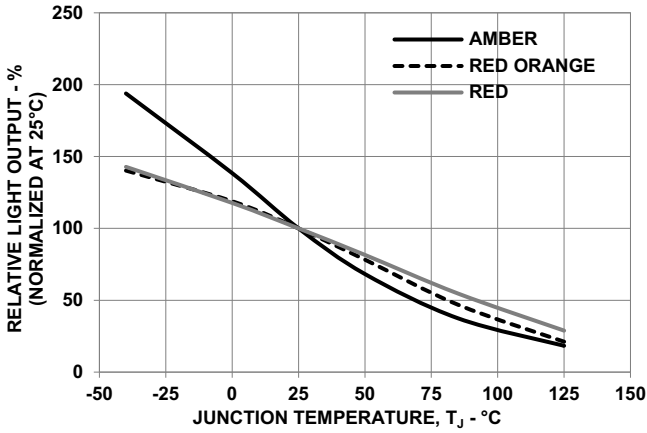

Figure 9: Dominant Wavelength Shift vs. Junction Temperature

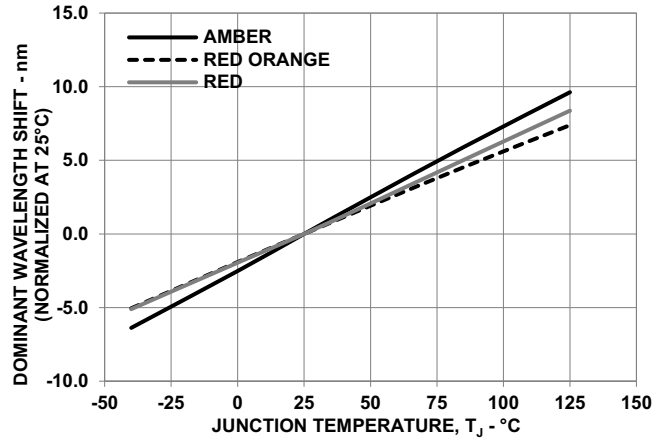

Figure 10: Maximum Forward Current vs. Ambient Temperature. Derated based on T_{JMAX} = 125°C

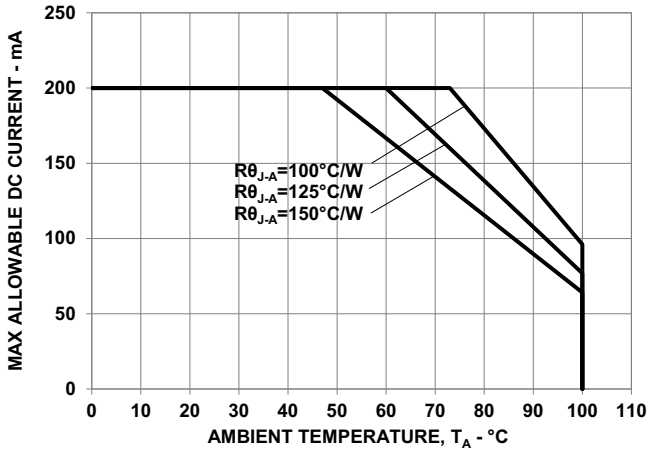

Figure 11: Maximum Forward Current vs. Solder Point Temperature. Derated based on T_{JMAX} = 125°C, R_{θJ-S} = 25°C/W

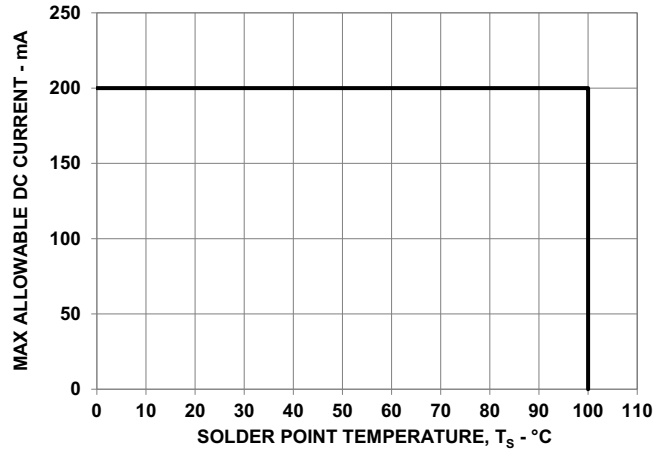
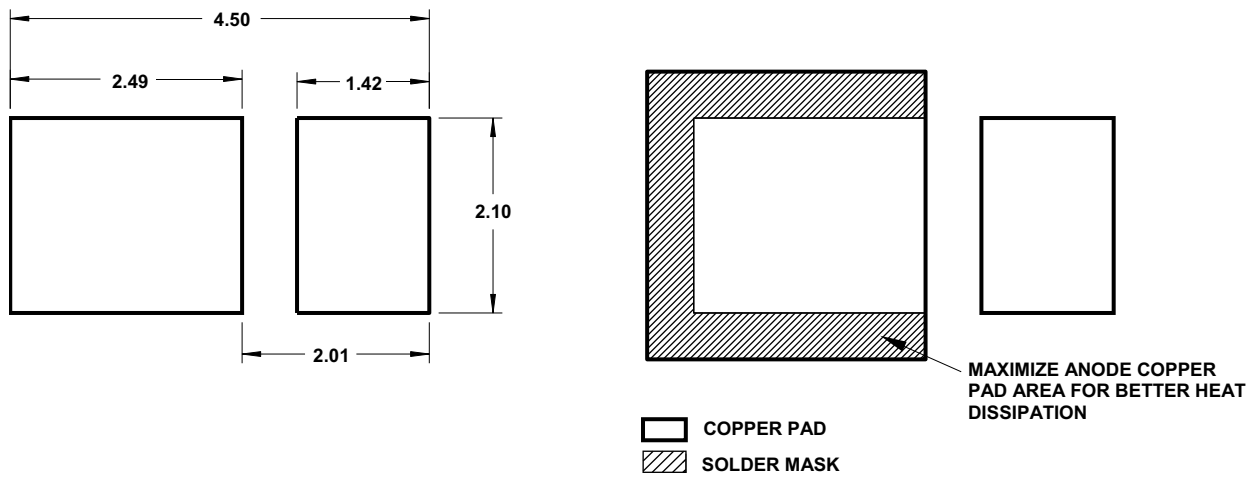
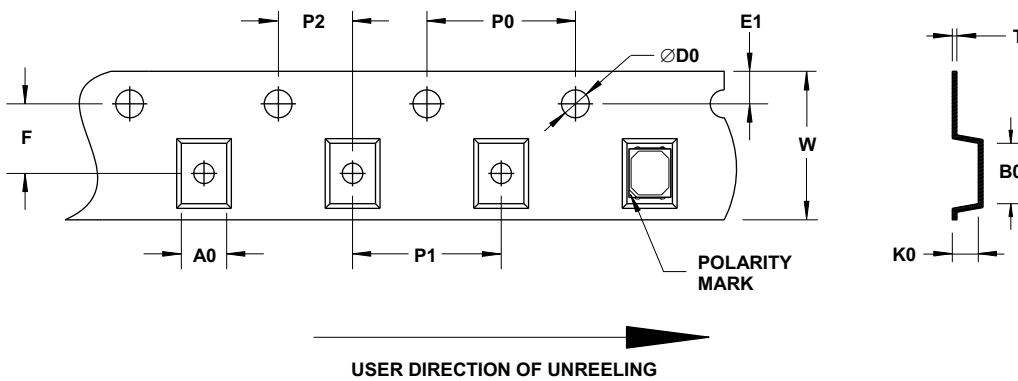

Figure 12: Recommended Soldering Land Pattern (mm)



NOTE: All dimensions are in millimeters (mm).

Figure 13: Carrier Tape Dimensions



F	P0	P1	P2	D0	E1	W
3.5 ± 0.05	4.0 ± 0.1	4.0 ± 0.1	2.0 ± 0.05	1.55 ± 0.05	1.75 ± 0.1	8.0 ± 0.2

T	B0	K0	A0
0.2 ± 0.05	3.8 ± 0.1	1.05 ± 0.1	3.1 ± 0.1

NOTE:

1. All dimensions in millimeters (mm).
2. Quantity per reel: 4000 pieces.

Figure 14: Reel Dimensions

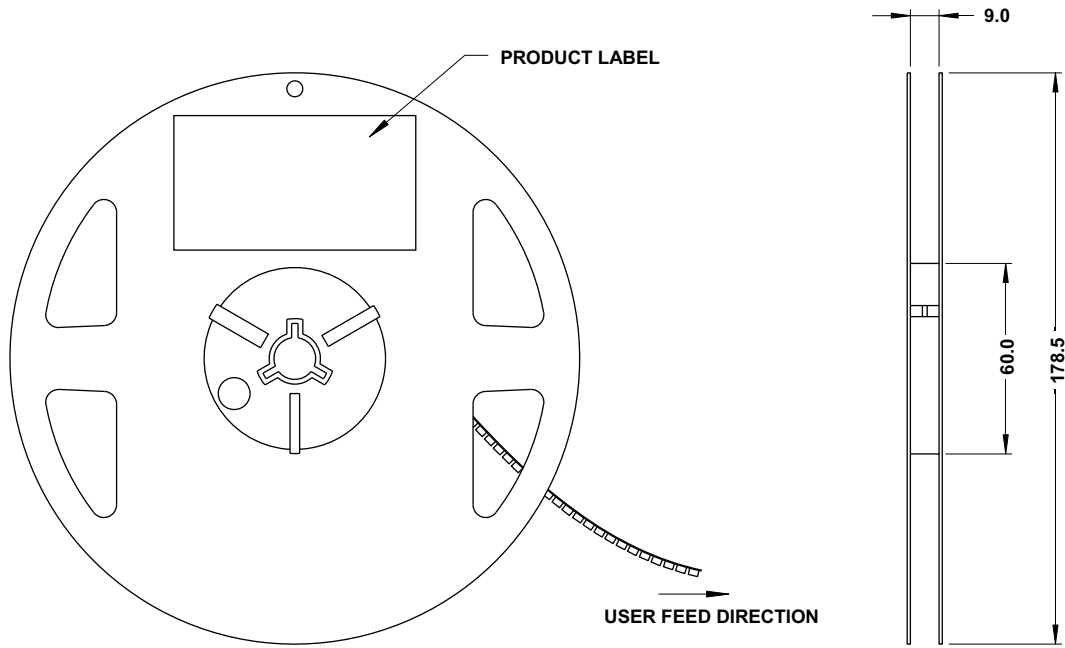

NOTE: All dimensions are in millimeters (mm).

Precautionary Notes

Soldering

- Do not perform reflow soldering more than twice. Observe necessary precautions of handling moisture-sensitive device as stated in the following section.
- Do not apply any pressure or force on the LED during reflow and after reflow when the LED is still hot.
- Use reflow soldering to solder the LED. Use hand soldering only for rework if unavoidable but it must be strictly controlled to the following conditions:
 - Soldering iron tip temperature = 315°C max.
 - Soldering duration = 3 seconds max.
 - Number of cycles = 1 only
 - Power of soldering iron = 50W max.
- Do not touch the LED package body with the soldering iron except for the soldering terminals, as it may cause damage to the LED.
- Confirm beforehand whether the functionality and performance of the LED is affected by soldering with hand soldering.

Figure 15: Recommended Lead-Free Reflow Soldering Profile

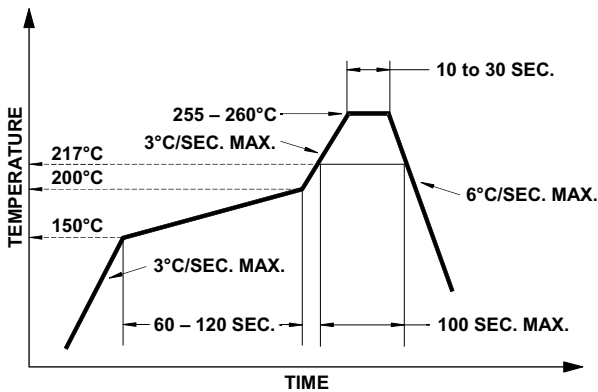
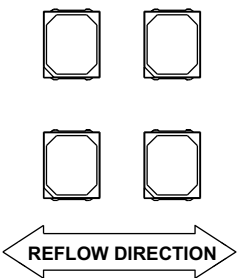

Figure 16: Recommended Board Reflow Direction



Handling Precautions

The encapsulation material of the LED is made of silicone for better product reliability. Compared to epoxy encapsulant, which is hard and brittle, silicone is softer and flexible. Observe special handling precautions during assembly of silicone-encapsulated LED products. Failure to comply might lead to damage and premature failure of the LED. Refer to Application Note AN5288, *Silicone Encapsulation for LED: Advantages and Handling Precautions*, for additional information.

- Do not poke sharp objects into the silicone encapsulant. Sharp objects, such as tweezers or syringes, might apply excessive force or even pierce through the silicone and induce failures to the LED die or wire bond.
- Do not touch the silicone encapsulant. Uncontrolled force acting on the silicone encapsulant might result in excessive stress on the wire bond. Hold the LED only by the body.
- Do not stack assembled PCBs together. Use an appropriate rack to hold the PCBs.
- The surface of the silicone material attracts dust and dirt easier than epoxy due to its surface tackiness. To remove foreign particles on the surface of silicone, use a cotton bud with isopropyl alcohol (IPA). During cleaning, rub the surface gently without putting too much pressure on the silicone. Ultrasonic cleaning is not recommended.
- For automated pick-and-place, Broadcom has tested a nozzle size with OD 3.5 mm to work with this LED. However, due to the possibility of variations in other parameters, such as pick-and-place machine maker/model and other settings of the machine, verify that the selected nozzle will not cause damage to the LED.

Handling of Moisture-Sensitive Devices

This product has a Moisture Sensitive Level 3 rating per JEDEC J-STD-020. Refer to Broadcom Application Note AN5305, *Handling of Moisture Sensitive Surface Mount Devices* for additional details and a review of proper handling procedures.

- Before use:
 - An unopened moisture barrier bag (MBB) can be stored at <40°C/90% RH for 12 months. If the actual shelf life has exceeded 12 months and the Humidity Indicator Card (HIC) indicates that baking is not required, then it is safe to reflow the LEDs per the original MSL rating.

- Do not open the MBB prior to assembly (for example, for IQC). If unavoidable, MBB must be properly resealed with fresh desiccant and HIC. The exposed duration must be taken in as floor life.
- Control after opening the MBB:
 - Read the HIC immediately upon opening of MBB.
 - Keep the LEDs at <30°/60% RH at all times, and complete all high temperature-related processes, including soldering, curing or rework within 168 hours.
- Control for unfinished reel:

Store unused LEDs in a sealed MBB with desiccant or a desiccator at <5% RH.
- Control of assembled boards:

If the PCB soldered with the LEDs is to be subjected to other high-temperature processes, store the PCB in a sealed MBB with desiccant or desiccator at <5% RH to ensure that all LEDs have not exceeded their floor life of 168 hours.
- Baking is required if:
 - The HIC indicator indicates a change in color for 10% and 5%, as stated on the HIC.
 - The LEDs are exposed to conditions of >30°C/60% RH at any time.
 - The LED's floor life exceeded 168 hours.

The recommended baking condition is: 60±5°C for 20 hours.

Baking can only be done once.
- Storage:

The soldering terminals of these Broadcom LEDs are silver plated. If the LEDs are exposed in an ambient environment for too long, the silver plating might be oxidized, thus affecting its solderability performance. As such, keep unused LEDs in a sealed moisture barrier bag (MBB) with desiccant or in desiccator at <5% RH.

Application Precautions

- The drive current of the LED must not exceed the maximum allowable limit across temperature as stated in the data sheet. Constant current driving is recommended to ensure consistent performance.
- Circuit design must cater to the whole range of forward voltage (V_F) of the LEDs to ensure the intended drive current can always be achieved.
- The LED exhibits slightly different characteristics at different drive currents, which may result in a larger variation of performance (meaning: intensity,

wavelength, and forward voltage). Set the application current as close as possible to the test current to minimize these variations.

- White LEDs must not be exposed to acidic environments and must not be used in the vicinity of any compound that may have acidic outgas, such as, but not limited to, acrylate adhesive. These environments have an adverse effect on LED performance.
- This LED is designed to have enhanced gas corrosion resistance. Its performance has been tested according to the conditions below:
 - IEC 60068-2-43: 25°C/75% RH, H₂S 15ppm, 21 days.
 - IEC 60068-2-42: 25°C/75% RH, SO₂ 25ppm, 21 days.
 - IEC 60068-2-60: 25°C/75% RH, SO₂ 200ppb, NO₂ 200ppb, H₂S 10ppb, Cl₂ 10ppb, 21 days.

As actual application might not be exactly similar to the test conditions, do verify that the LED will not be damaged by prolonged exposure in the intended environment.
- Avoid rapid changes in ambient temperature especially in high-humidity environments as this will cause condensation on the LED.
- If the LED is intended to be used in harsh or outdoor environments, protect the LED against damages caused by rain, water, dust, oil, corrosive gases, external mechanical stresses, and so on.

Thermal Management

The optical, electrical, and reliability characteristics of the LED are affected by temperature. Keep the junction temperature (T_J) of the LED below the allowable limit at all times. T_J can be calculated as follows:

$$T_J = T_A + R_{\theta J-A} \times I_F \times V_{Fmax}$$

- where
- T_A = Ambient temperature (°C)
 - $R_{\theta J-A}$ = Thermal resistance from LED junction to ambient (°C/W)
 - I_F = Forward current (A)
 - V_{Fmax} = Maximum forward voltage (V)

The complication of using this formula lies in T_A and $R_{\theta J-A}$. Actual T_A is sometimes subjective and hard to determine. $R_{\theta J-A}$ varies from system to system depending on design and is usually not known.

Another way of calculating T_J is by using the solder point temperature, T_S as follows:

$$T_J = T_S + R_{\theta J-S} \times I_F \times V_{Fmax}$$

where T_S = LED solder point temperature ($^{\circ}\text{C}$) as shown in the following figure

$R_{\theta J-S}$ = Thermal resistance from junction to solder point ($^{\circ}\text{C}/\text{W}$)

I_F = Forward current (A)

V_{Fmax} = Maximum forward voltage (V)

Figure 17: Solder Point Temperature on PCB

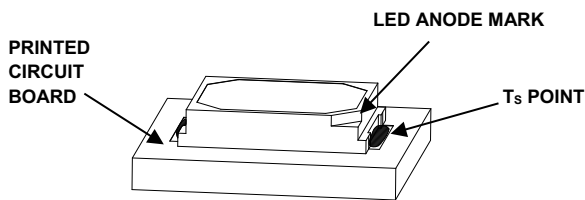

T_S can be easily measured by mounting a thermocouple on the soldering joint as shown in preceding figure, while $R_{\theta J-S}$ is provided in the data sheet. Verify the T_S of the LED in the final product to ensure that the LEDs are operating within all maximum ratings stated in the data sheet.

Eye Safety Precautions

LEDs may pose optical hazards when in operation. Do not look directly at operating LEDs as it may be harmful to the eyes. For safety reasons, use appropriate shielding or personnel protection equipment.

Disclaimer

Broadcom's products and software are not specifically designed, manufactured, or authorized for sale as parts, components, or assemblies for the planning, construction, maintenance, or direct operation of a nuclear facility or for use in medical devices or applications. The customer is solely responsible, and waives all rights to make claims against Broadcom or its suppliers, for all loss, damage, expense, or liability in connection with such use.

Copyright © 2023 Broadcom. All Rights Reserved. The term "Broadcom" refers to Broadcom Inc. and/or its subsidiaries. For more information, go to www.broadcom.com. All trademarks, trade names, service marks, and logos referenced herein belong to their respective companies.

Broadcom reserves the right to make changes without further notice to any products or data herein to improve reliability, function, or design. Information furnished by Broadcom is believed to be accurate and reliable. However, Broadcom does not assume any liability arising out of the application or use of this information, nor the application or use of any product or circuit described herein, neither does it convey any license under its patent rights nor the rights of others.

