

CSMM-CWG3-NX7x2

Low-Power 3528 PLCC-2 Surface-Mount LED

Description

The Broadcom[®] CSMM-CWG3 surface-mount LEDs use InGaN chip technology with superior package design to enable them to produce better light output performance. They are able to dissipate heat more efficiently, resulting in better performance with higher reliability.

These LEDs operate under a wide range of environmental conditions making them ideal for various applications.

To facilitate easy pick and place assembly, the LEDs are packed in tape and reel. Every reel is shipped in single intensity and color bin to provide close uniformity.

Features

- High reliability package with enhanced silicone resin encapsulation
- Available in CCT 4500K-10000K
- Product qualified as per AEC-Q101 guidelines
- Moisture sensitivity level 3

Applications

- Automotive interior lighting
 - Ambient lighting
 - Indicators and switches
 - Car door trim lighting
- Electronic signs and signals
 - Channel lettering
 - Contour lighting
 - Indoor variable message signs
- Office automations, home appliances, and industrial equipment
 - Front panel backlighting
 - Push button backlighting
 - Display backlighting
 - Scanner lighting

CAUTION! This LED is Class 2 ESD sensitive per ANSI/ESDA/JEDEC JS-001. Observe appropriate precautions during handling and processing. Refer to the application note AN-1142 for additional details.

Figure 1: Package Drawing

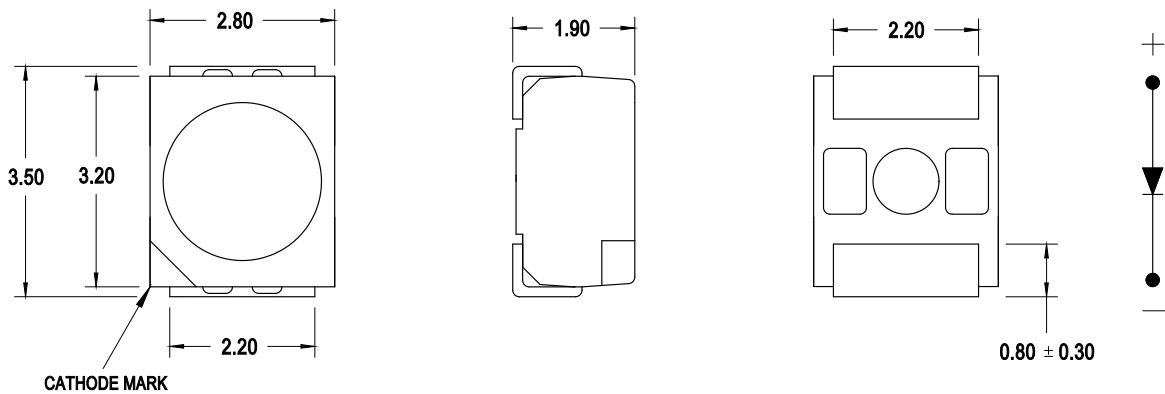

NOTE:

1. All dimensions are in millimeters (mm).
2. Tolerance is ± 0.20 mm unless otherwise specified.
3. Encapsulation = silicone.
4. Terminal finish = silver plating.

Device Selection Guide ($T_J = 25^\circ\text{C}$, $I_F = 20$ mA)

| Part Number | Correlated Color Temperature, CCT (Kelvin) | Luminous Intensity, I_V (mcd) ^{a, b} | | | Luminous Flux (lm) ^c |
|-----------------|--|---|------|------|---------------------------------|
| | Typ. | Min. | Typ. | Max. | |
| CSMM-CWG3-NX7A2 | 7000 to 10000 | 2240 | 2680 | 4500 | 8.0 |
| CSMM-CWG3-NX7B2 | 5600 to 7000 | 2240 | 2680 | 4500 | 8.0 |
| CSMM-CWG3-NX7C2 | 5000 to 5600 | 2240 | 2680 | 4500 | 8.0 |
| CSMM-CWG3-NX7D2 | 4500 to 5000 | 2240 | 2680 | 4500 | 8.0 |

a. The luminous intensity, I_V , is measured at the mechanical axis of the package, and it is tested with a single current pulse condition. The actual peak of the spatial radiation pattern may not be aligned with the axis.

b. Tolerance is $\pm 12\%$.

c. For reference only.

Absolute Maximum Ratings

| Parameters | CSMM-CWG3-NX7x2 | Unit |
|-----------------------------------|-----------------|------------------|
| DC Forward Current ^a | 30 | mA |
| Peak Forward Current ^b | 200 | mA |
| Power Dissipation | 96 | mW |
| Reverse Voltage | 5 | V |
| LED Junction Temperature | 125 | $^\circ\text{C}$ |
| Operating Temperature Range | -40 to +100 | $^\circ\text{C}$ |
| Storage Temperature Range | -40 to +100 | $^\circ\text{C}$ |

a. Derate linearly as shown in Figure 11 and Figure 12.

b. Duty factor = 10%, frequency = 1 kHz, $T_A = 25^\circ\text{C}$.

Optical and Electrical Characteristics ($T_J = 25^\circ\text{C}$, $I_F = 20\text{ mA}$)

| Parameters | Min. | Typ. | Max. | Unit |
|--|------|------|------|--------------------|
| Viewing Angle, $2\theta_{1/2}^a$ | — | 120 | — | ° |
| Forward Voltage, V_F^b | 2.40 | 2.77 | 3.20 | V |
| Reverse Current, I_R at $V_R = 5\text{V}$ | — | — | 10 | μA |
| Color Rendering Index, CRI | 80 | — | — | — |
| Thermal Resistance, $R_{\theta\text{J-S}}^c$ | — | 100 | — | $^\circ\text{C/W}$ |

- $\theta_{1/2}$ is the off-axis angle where the luminous intensity is half of the peak intensity.
- Forward voltage tolerance is $\pm 0.1\text{V}$.
- Thermal resistance from LED junction to the solder point.

Part Numbering System

C S M M - C W x₁ 3 - N x₂ x₃ x₄ x₅

| Code | Description | Option | |
|----------------|--------------------------|--------|--|
| x ₁ | Color Rendering Index | G | CRI ≥ 80 |
| x ₂ | Minimum Intensity Bin | X | Minimum bin X |
| x ₃ | Number of Intensity Bins | 7 | 3 intensity sub bins, starting from bin X2 |
| x ₄ | Color Bins | A | 5K and 5L only |
| | | B | 6K and 6L only |
| | | C | 7K and 7L only |
| | | D | 8K and 8L only |
| x ₅ | Test Option | 2 | Test Current = 20 mA |

Part Number Example

CSMM-CWG3-NX7B2

- x₁: G — CRI ≥ 80
- x₂: X — Minimum intensity bin X
- x₃: 7 — 3 intensity sub bins, starting from sub bin X2
- x₄: B — Color bin 6Ka, 6Kb, 6Kc, 6Kd, 6La, 6Lb, 6Lc, and 6Ld only
- x₅: 2 — Test current = 20 mA

Bin Information

Intensity Bin Limits (CAT)

| Bin ID | Luminous Intensity, I_V (lm) | |
|--------|--------------------------------|------|
| | Min. | Max. |
| X2 | 2240 | 2850 |
| Y1 | 2850 | 3550 |
| Y2 | 3550 | 4500 |

Tolerance = $\pm 12\%$.

Example of bin information on reel and packaging label:

CAT: X2 – Flux bin N
 BIN: 6La – Color bin 2A
 VF: F05 – Forward Voltage bin G02

Forward Voltage Bin Limits (VF)

| Bin ID | Forward Voltage, V_F (V) | |
|--------|----------------------------|------|
| | Min. | Max. |
| F03 | 2.4 | 2.6 |
| F04 | 2.6 | 2.8 |
| F05 | 2.8 | 3.0 |
| F06 | 3.0 | 3.2 |

Tolerance = $\pm 0.1V$.

Color Bin Limits (BIN)

| CCT | Bin ID | Chromaticity Coordinates | |
|-----------------|--------|--------------------------|--------|
| | | x | y |
| 7000K to 10000K | 5Ka | 0.2960 | 0.2590 |
| | | 0.3037 | 0.2702 |
| | | 0.3018 | 0.2757 |
| | | 0.2935 | 0.2635 |
| | 5Kb | 0.2935 | 0.2635 |
| | | 0.3018 | 0.2757 |
| | | 0.2999 | 0.2811 |
| | | 0.2910 | 0.2680 |
| | 5Kc | 0.3037 | 0.2702 |
| | | 0.3130 | 0.2840 |
| | | 0.3115 | 0.2905 |
| | | 0.3018 | 0.2757 |
| | 5Kd | 0.3018 | 0.2757 |
| | | 0.3115 | 0.2905 |
| | | 0.3100 | 0.2970 |
| | | 0.2999 | 0.2811 |
| | 5La | 0.2910 | 0.2680 |
| | | 0.2999 | 0.2811 |
| | | 0.2976 | 0.2877 |
| | | 0.2880 | 0.2735 |
| | 5Lb | 0.2880 | 0.2735 |
| | | 0.2976 | 0.2877 |
| | | 0.2952 | 0.2943 |
| | | 0.2850 | 0.2790 |
| | 5Lc | 0.2999 | 0.2811 |
| | | 0.3100 | 0.2970 |
| | | 0.3085 | 0.3045 |
| | | 0.2976 | 0.2877 |
| | 5Ld | 0.2976 | 0.2877 |
| | | 0.3085 | 0.3045 |
| | | 0.3070 | 0.3120 |
| | | 0.2952 | 0.2943 |

| CCT | Bin ID | Chromaticity Coordinates | |
|----------------|--------|--------------------------|--------|
| | | x | y |
| 5600K to 7000K | 6Ka | 0.3130 | 0.2840 |
| | | 0.3215 | 0.2971 |
| | | 0.3207 | 0.3053 |
| | | 0.3115 | 0.2905 |
| | 6Kb | 0.3115 | 0.2905 |
| | | 0.3207 | 0.3053 |
| | | 0.3199 | 0.3135 |
| | | 0.3100 | 0.2970 |
| | 6Kc | 0.3215 | 0.2971 |
| | | 0.3300 | 0.3100 |
| | | 0.3300 | 0.3200 |
| | | 0.3207 | 0.3053 |
| | 6Kd | 0.3207 | 0.3053 |
| | | 0.3300 | 0.3200 |
| | | 0.3300 | 0.3300 |
| | | 0.3199 | 0.3135 |
| | 6La | 0.3100 | 0.2970 |
| | | 0.3199 | 0.3135 |
| | | 0.3192 | 0.3215 |
| | | 0.3085 | 0.3045 |
| | 6Lb | 0.3085 | 0.3045 |
| | | 0.3192 | 0.3215 |
| | | 0.3184 | 0.3294 |
| | | 0.3070 | 0.3120 |
| 6Lc | 0.3199 | 0.3135 | |
| | 0.3300 | 0.3300 | |
| | 0.3300 | 0.3385 | |
| | 0.3192 | 0.3215 | |
| 6Ld | 0.3192 | 0.3215 | |
| | 0.3300 | 0.3385 | |
| | 0.3300 | 0.3470 | |
| | 0.3184 | 0.3294 | |

| CCT | Bin ID | Chromaticity Coordinates | |
|-------------------|--------|--------------------------|--------|
| | | x | y |
| 5000K to 5600K | 7Ka | 0.3300 | 0.3100 |
| | | 0.3362 | 0.3202 |
| | | 0.3366 | 0.3304 |
| | | 0.3300 | 0.3200 |
| | 7Kb | 0.3300 | 0.3200 |
| | | 0.3366 | 0.3304 |
| | | 0.3370 | 0.3406 |
| | | 0.3300 | 0.3300 |
| | 7Kc | 0.3362 | 0.3202 |
| | | 0.3433 | 0.3307 |
| | | 0.3442 | 0.3414 |
| | | 0.3366 | 0.3304 |
| | 7Kd | 0.3366 | 0.3304 |
| | | 0.3442 | 0.3414 |
| | | 0.3450 | 0.3520 |
| | | 0.3370 | 0.3406 |
| | 7La | 0.3300 | 0.3300 |
| | | 0.3370 | 0.3406 |
| | | 0.3374 | 0.3494 |
| | | 0.3300 | 0.3385 |
| | 7Lb | 0.3300 | 0.3385 |
| | | 0.3374 | 0.3494 |
| | | 0.3377 | 0.3581 |
| | | 0.3300 | 0.3470 |
| | 7Lc | 0.3370 | 0.3406 |
| | | 0.3450 | 0.3520 |
| | | 0.3460 | 0.3615 |
| | | 0.3374 | 0.3494 |
| | 7Ld | 0.3374 | 0.3494 |
| | | 0.3460 | 0.3615 |
| | | 0.3470 | 0.3710 |
| | | 0.3377 | 0.3581 |

| CCT | Bin ID | Chromaticity Coordinates | |
|-------------------|--------|--------------------------|--------|
| | | x | y |
| 4500K to 5000K | 8Ka | 0.3433 | 0.3307 |
| | | 0.3506 | 0.3426 |
| | | 0.3521 | 0.3535 |
| | | 0.3442 | 0.3414 |
| | 8Kb | 0.3442 | 0.3414 |
| | | 0.3521 | 0.3535 |
| | | 0.3535 | 0.3644 |
| | | 0.3450 | 0.3520 |
| | 8Kc | 0.3521 | 0.3535 |
| | | 0.3506 | 0.3426 |
| | | 0.3600 | 0.3570 |
| | | 0.3620 | 0.3685 |
| | 8Kd | 0.3521 | 0.3535 |
| | | 0.3620 | 0.3685 |
| | | 0.3640 | 0.3800 |
| | | 0.3535 | 0.3644 |
| | 8La | 0.3450 | 0.3520 |
| | | 0.3535 | 0.3644 |
| | | 0.3549 | 0.3746 |
| | | 0.3460 | 0.3615 |
| | 8Lb | 0.3460 | 0.3615 |
| | | 0.3549 | 0.3746 |
| | | 0.3562 | 0.3847 |
| | | 0.3470 | 0.3710 |
| | 8Lc | 0.3535 | 0.3644 |
| | | 0.3640 | 0.3800 |
| | | 0.3655 | 0.3905 |
| | | 0.3549 | 0.3746 |
| | 8Ld | 0.3549 | 0.3746 |
| | | 0.3655 | 0.3905 |
| | | 0.3670 | 0.4010 |
| | | 0.3562 | 0.3847 |

Tolerance = ± 0.01 .

Figure 2: Chromaticity Diagram

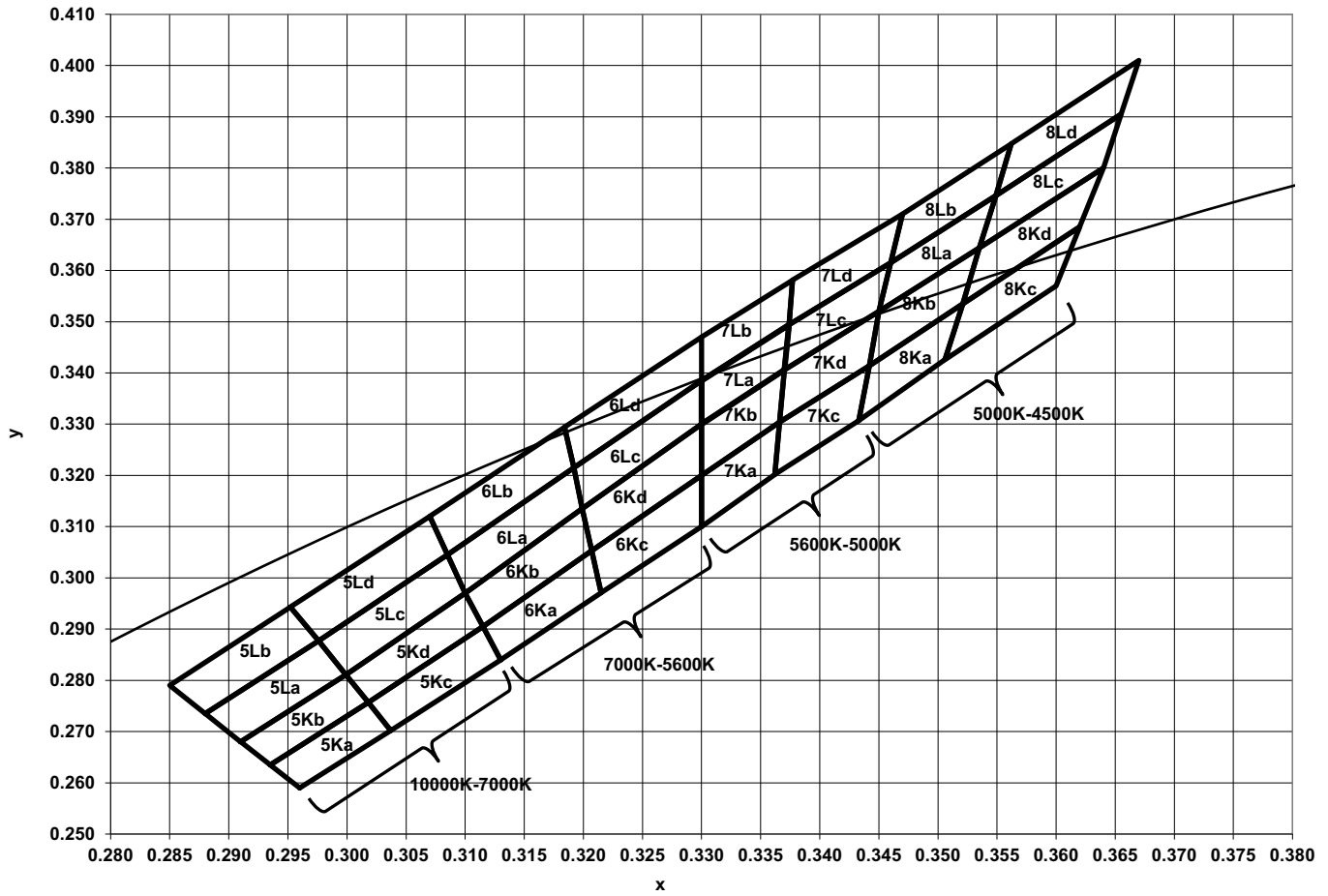

Figure 3: Spectral Power Distribution

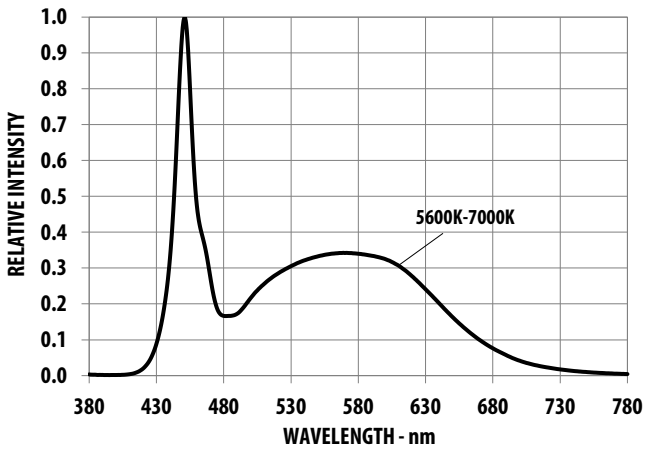

Figure 4: Forward Current vs. Forward Voltage

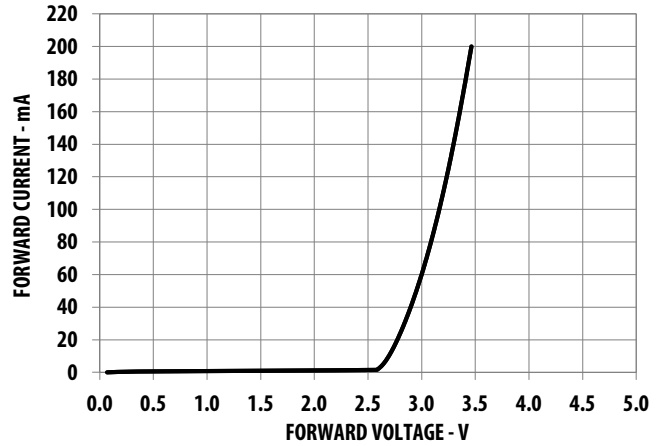

Figure 5: Relative Luminous Intensity vs. Mono Pulse Current

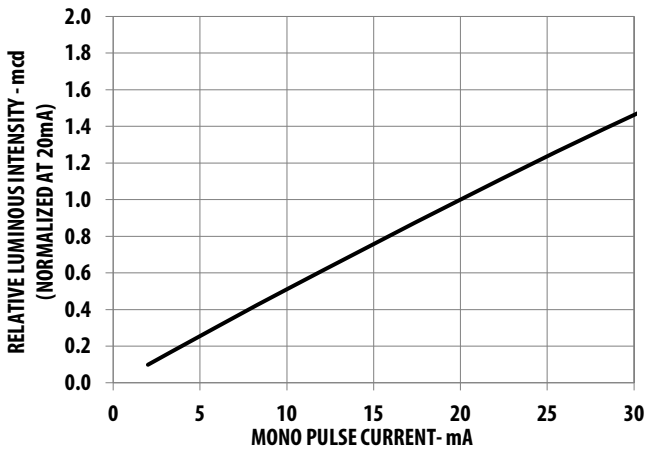

Figure 6: Radiation Pattern

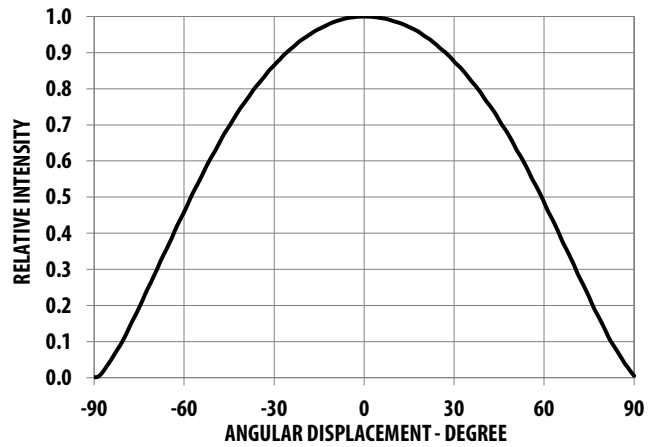

Figure 7: Chromaticity Coordinate Shift vs. Mono Pulse Current (5600K to 7000K)

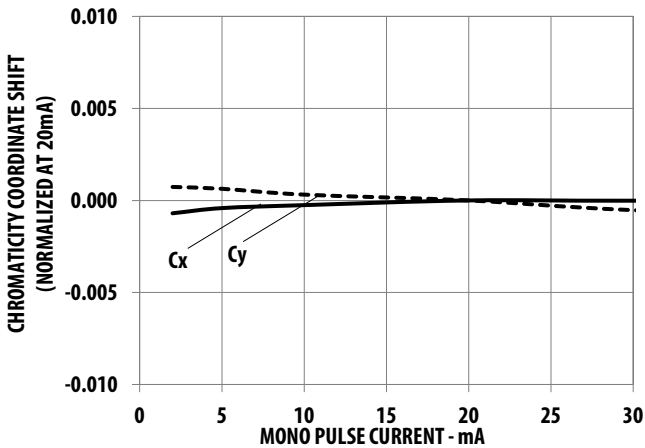

Figure 8: Forward Voltage Shift vs. Junction Temperature

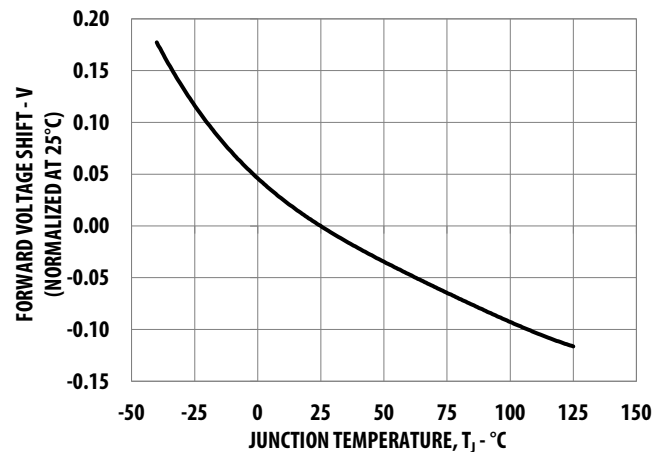

Figure 9: Relative Luminous Intensity vs. Junction Temperature

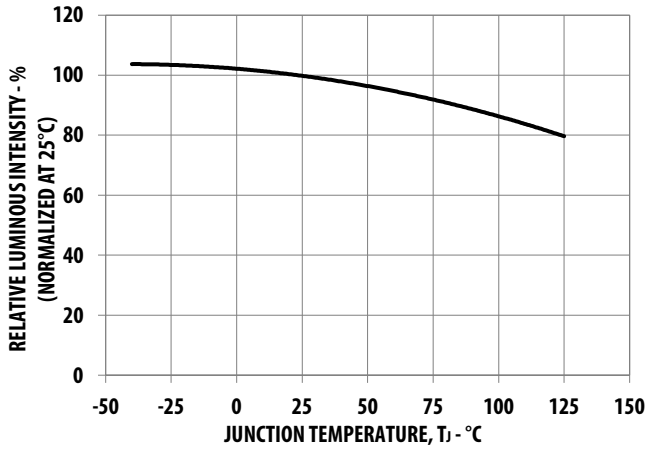

Figure 10: Chromaticity Coordinate Shift vs. Junction Temperature (5600K to 7000K)

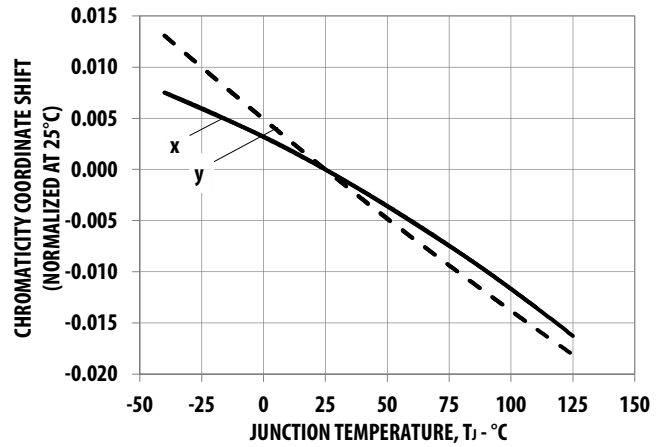

Figure 11: Maximum Forward Current vs. Ambient Temperature. Derated Based on $T_{JMAX} = 125^\circ\text{C}$

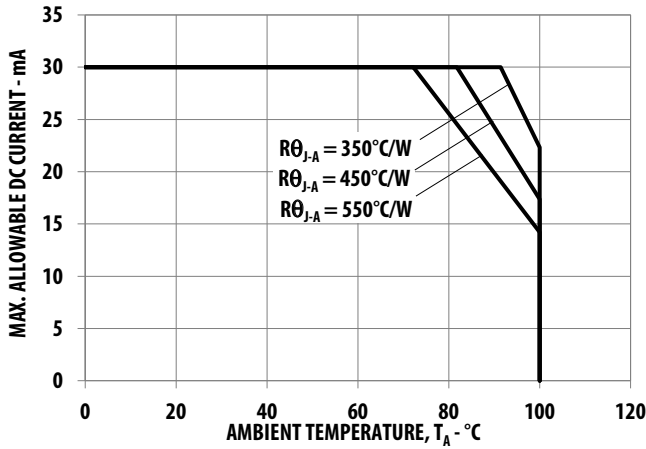

Figure 12: Maximum Forward Current vs. Solder Point Temperature. Derated Based on $T_{JMAX} = 125^\circ\text{C}$, $R_{\theta J-S} = 100^\circ\text{C/W}$

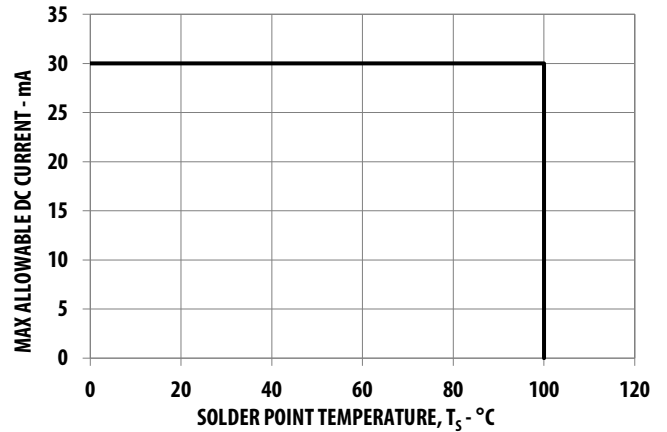
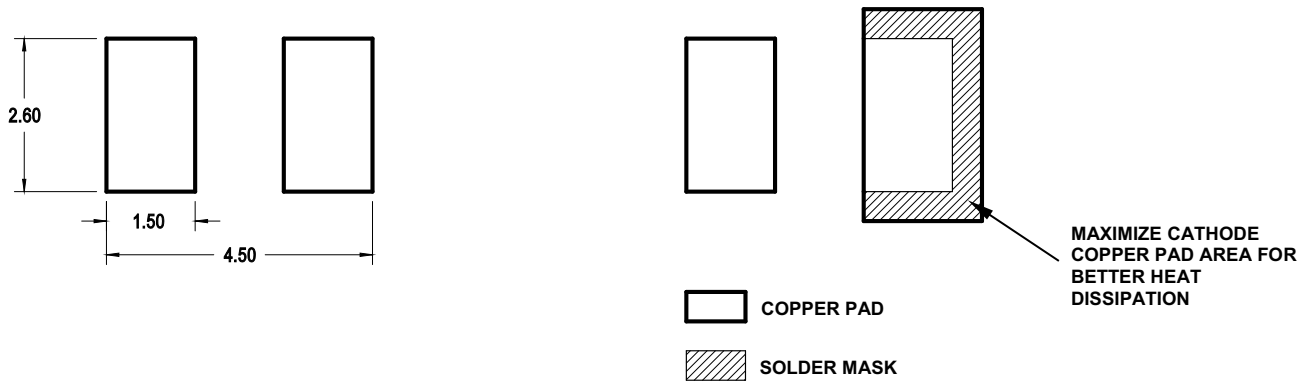
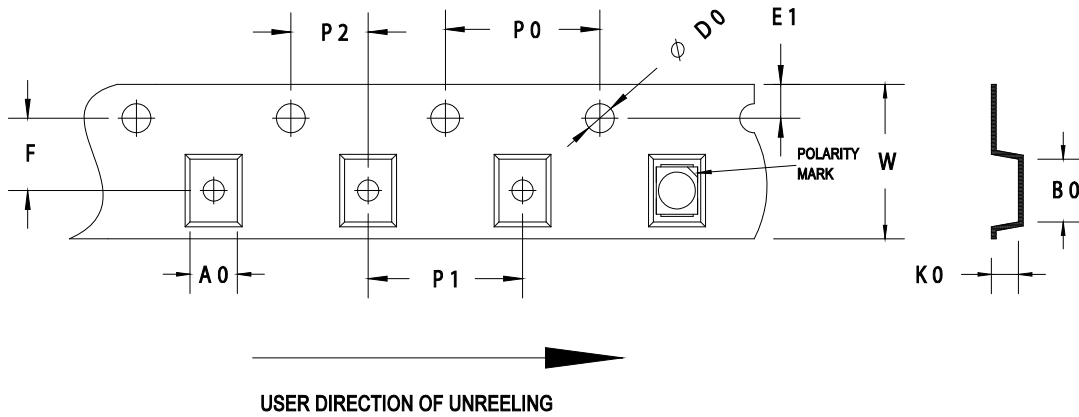

Figure 13: Maximum Forward Current vs. Ambient Temperature



NOTE: All dimensions are in millimeters (mm).

Figure 14: Carrier Tape Dimensions



| F | P0 | P1 | P2 | D0 | E1 | W |
|---------|---------|---------|----------|-----------|----------|---------|
| 3.5±0.1 | 4.0±0.1 | 4.0±0.1 | 2.0±0.05 | 1.55±0.05 | 1.75±0.1 | 8.0±0.2 |

| B0 | K0 | A0 |
|----------|----------|---------|
| 3.85±0.1 | 2.15±0.1 | 3.1±0.1 |

NOTE: All dimensions are in millimeters (mm).

Figure 15: Reel Dimensions

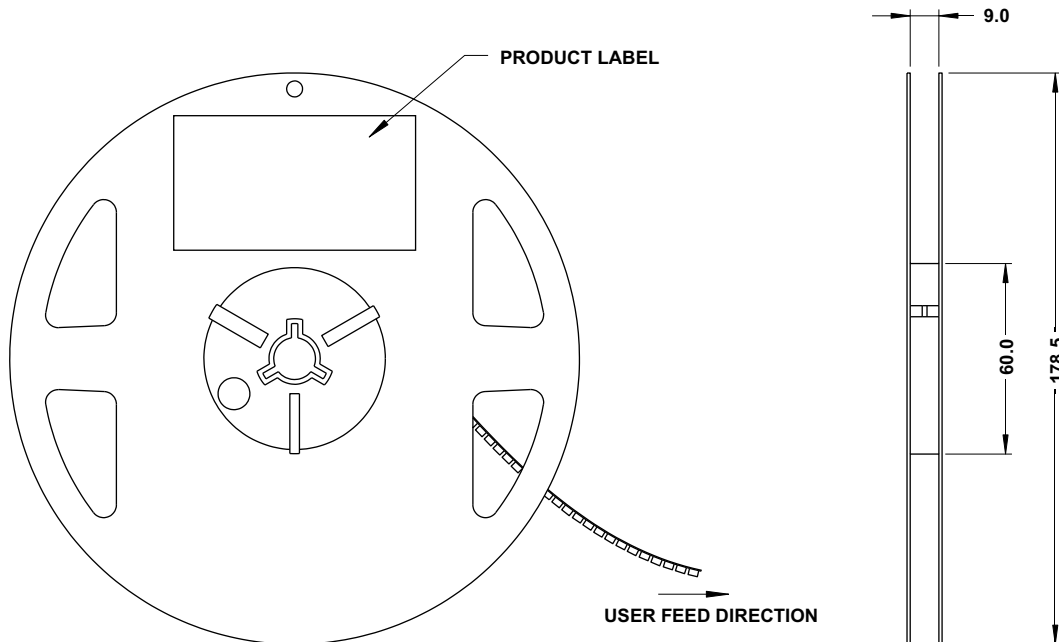

NOTE: All dimensions are in millimeters (mm).

Precautionary Notes

Soldering

- Do not perform reflow soldering more than twice. Observe necessary precautions of handling moisture-sensitive device as stated in the following section.
- Do not apply any pressure or force on the LED during reflow and after reflow when the LED is still hot.
- Use reflow soldering to solder the LED. Use hand soldering only for rework if unavoidable, but it must be strictly controlled to the following conditions:
 - Soldering iron tip temperature = 315°C maximum.
 - Soldering duration = 3 seconds maximum.
 - Number of cycles = 1 only.
 - Power of soldering iron = 50W maximum.
- Do not touch the LED package body with the soldering iron except for the soldering terminals because it can cause damage to the LED.
- Confirm beforehand whether the functionality and performance of the LED is affected by soldering with hand soldering.

Figure 16: Recommended Lead-Free Reflow Soldering Profile

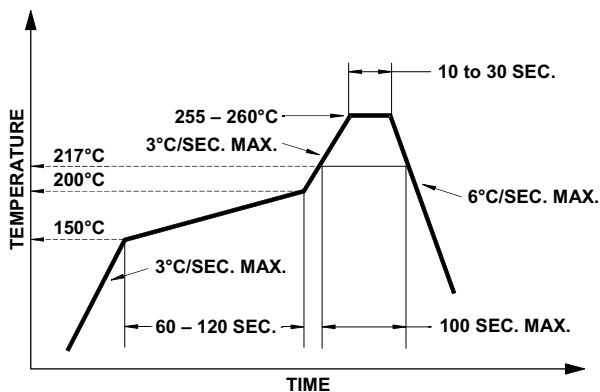
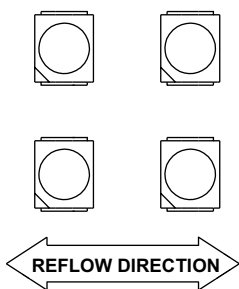

Figure 17: Recommended Board Reflow Direction



Handling Precautions

The encapsulation material of the LED is made of silicone for better product reliability. Compared to epoxy encapsulant, which is hard and brittle, silicone is softer and flexible. Observe special handling precautions during assembly of silicone encapsulated LED products. Failure to comply might lead to damage and premature failure of the LED. Refer to Broadcom Application Note AN5288, *Silicone Encapsulation for LED: Advantages and Handling Precautions*, for additional information.

- Do not poke sharp objects into the silicone encapsulant. Sharp objects, such as tweezers or syringes, might apply excessive force or even pierce through the silicone and induce failures to the LED die or wire bond.
- Do not touch the silicone encapsulant. Uncontrolled force acting on the silicone encapsulant might result in excessive stress on the wire bond. Hold the LED only by the body.
- Do not stack assembled PCBs together. Use an appropriate rack to hold the PCBs.
- The surface of silicone material attracts dust and dirt easier than epoxy due to its surface tackiness. To remove foreign particles on the surface of silicone, use a cotton bud with isopropyl alcohol (IPA). During cleaning, rub the surface gently without putting too much pressure on the silicone. Ultrasonic cleaning is not recommended.
- For automated pick and place, Broadcom has tested a nozzle size with OD 3.5 mm to work with this LED. However, due to the possibility of variations in other parameters such as pick and place machine maker/model, and other settings of the machine, verify that the selected nozzle will not cause damage to the LED.

Handling of Moisture-Sensitive Devices

This product has a Moisture Sensitive Level 3 rating per JEDEC J-STD-020. Refer to Broadcom Application Note AN5305, *Handling of Moisture Sensitive Surface Mount Devices*, for additional details and a review of proper handling procedures.

Before use:

- An unopened moisture barrier bag (MBB) can be stored at $40^{\circ}\text{C}/90\% \text{ RH}$ for 12 months. If the actual shelf life has exceeded 12 months and the humidity indicator card (HIC) indicates that baking is not required, it is safe to reflow the LEDs per the original MSL rating.
- Do not open the MBB prior to assembly (for example, for IQC). If unavoidable, MBB must be properly resealed with fresh desiccant and HIC. The exposed duration must be taken in as floor life.

Control after opening the MBB:

- Read the HIC immediately upon opening of the MBB.
- Keep the LEDs at $30^{\circ}/60\% \text{ RH}$ at all times, and complete all high temperature-related processes, including soldering, curing, or rework within 168 hours.

Control for unfinished reel:

Store unused LEDs in a sealed MBB with desiccant or a desiccator at $5\% \text{ RH}$.

Control of assembled boards:

If the PCB soldered with the LEDs is to be subjected to other high-temperature processes, store the PCB in a sealed MBB with desiccant or desiccator at $5\% \text{ RH}$ to ensure that all LEDs have not exceeded their floor life of 168 hours.

Baking is required if the following conditions exist:

- The HIC indicator indicates a change in color for 10% and 5%, as stated on the HIC.
- The LEDs are exposed to conditions of $30^{\circ}\text{C}/60\% \text{ RH}$ at any time.
- The LED's floor life exceeded 168 hours.

The recommended baking condition is $60^{\circ}\text{C} \pm 5^{\circ}\text{C}$ for 20 hours.

Baking can only be done once.

Storage:

The soldering terminals of these Broadcom LEDs are silver plated. If the LEDs are exposed in ambient environment for too long, the silver plating might be oxidized, thus affecting its solderability performance. As such, keep unused LEDs in a sealed MBB with desiccant or in a desiccator at $5\% \text{ RH}$.

Application Precautions

- The drive current of the LED must not exceed the maximum allowable limit across temperature as stated in the data sheet. Constant current driving is recommended to ensure consistent performance.
- Circuit design must cater to the whole range of forward voltage (V_F) of the LEDs to ensure the intended drive current can always be achieved.
- The LED exhibits slightly different characteristics at different drive currents, which can result in a larger variation of performance (such as intensity, wavelength, and forward voltage). Set the application current as close as possible to the test current to minimize these variations.
- Do not use the LED in the vicinity of material with sulfur content or in environments of high gaseous sulfur compounds and corrosive elements. Examples of material that might contain sulfur are rubber gaskets, room-temperature vulcanizing (RTV) silicone rubber, rubber gloves, and so on. Prolonged exposure to such environments can affect the optical characteristics and product life.
- White LEDs must not be exposed to acidic environments and must not be used in the vicinity of any compound that can have acidic outgas, such as, but not limited to, acrylate adhesive. These environments have an adverse effect on LED performance.
- Avoid rapid change in ambient temperatures, especially in high-humidity environments, because they cause condensation on the LED.
- If the LED is intended to be used in a harsh or an outdoor environment, protect the LED against damages caused by rain water, water, dust, oil, corrosive gases, external mechanical stresses, and so on.

Thermal Management

The optical, electrical, and reliability characteristics of the LED are affected by temperature. Keep the junction temperature (T_J) of the LED below the allowable limit at all times. T_J can be calculated as follows:

$$T_J = T_A + R_{\theta J-A} \times I_F \times V_{Fmax}$$

where:

T_A = Ambient temperature ($^{\circ}\text{C}$)

$R_{\theta J-A}$ = Thermal resistance from LED junction to ambient ($^{\circ}\text{C}/\text{W}$)

I_F = Forward current (A)

V_{Fmax} = Maximum forward voltage (V)

The complication of using this formula lies in T_A and $R_{\theta J-A}$. Actual T_A is sometimes subjective and hard to determine. $R_{\theta J-A}$ varies from system to system depending on design and is usually not known.

Another way of calculating T_J is by using the solder point temperature, T_S as follows:

$$T_J = T_S + R_{\theta J-S} \times I_F \times V_{Fmax}$$

where:

T_S = LED solder point temperature as shown in the following figure ($^{\circ}\text{C}$)

$R_{\theta J-S}$ = Thermal resistance from junction to solder point ($^{\circ}\text{C}/\text{W}$)

I_F = Forward current (A)

V_{Fmax} = Maximum forward voltage (V)

Figure 18: Solder Point Temperature on PCB

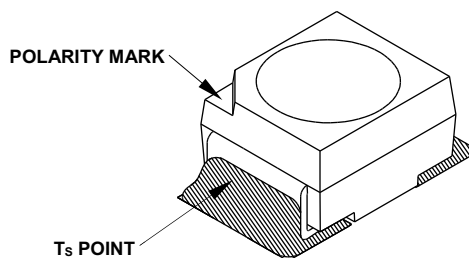

T_S can be easily measured by mounting a thermocouple on the soldering joint as shown in preceding figure, while $R_{\theta J-S}$ is provided in the data sheet. Verify the T_S of the LED in the final product to ensure that the LEDs are operating within all maximum ratings stated in the data sheet.

Eye Safety Precautions

LEDs can pose optical hazards when in operation. Do not look directly at operating LEDs because it might be harmful to the eyes. For safety reasons, use appropriate shielding or personal protective equipment.

Disclaimer

Broadcom's products and software are not specifically designed, manufactured, or authorized for sale as parts, components, or assemblies for the planning, construction, maintenance, or direct operation of a nuclear facility or for use in medical devices or applications. The customer is solely responsible, and waives all rights to make claims against Broadcom or its suppliers, for all loss, damage, expense, or liability in connection with such use.

Copyright © 2022-2023 Broadcom. All Rights Reserved. The term "Broadcom" refers to Broadcom Inc. and/or its subsidiaries. For more information, go to www.broadcom.com. All trademarks, trade names, service marks, and logos referenced herein belong to their respective companies.

Broadcom reserves the right to make changes without further notice to any products or data herein to improve reliability, function, or design. Information furnished by Broadcom is believed to be accurate and reliable. However, Broadcom does not assume any liability arising out of the application or use of this information, nor the application or use of any product or circuit described herein, neither does it convey any license under its patent rights nor the rights of others.

