

## White Paper

By Michael Wappmannsberger

Usually, an IGBT (Insulated Gate Bipolar Transistor) is described in the following way: "An IGBT is a combination of a field effect transistor and a bipolar transistor where an N-channel FET controls a bipolar transistor". Although this sentence describes the basics very well, in the case of IGBT applications in the high power range, the complexity of the IGBT control circuit is in fact much higher than in the case of the control of a small MOSFET.

For example, the control of a MOSFET is usually referred to as no load, since the currents needed in a MOSFET for switching are usually negligible.

There can be no question of this in the case of power IGBTs, because several watts are often needed for control. In addition, internal capacitances that need to be reloaded and that play hardly any role in the control of small MOSFETs, can no longer be so easily neglected in this case.

The correct and, above all, efficient control of IGBTs is a complex process, for which a driver attuned to the IGBT is required. In addition, most modern IGBT drivers provide protection circuits and safety functions in order to protect to the IGBT in case of a malfunction that would otherwise often lead to the complete destruction of the IGBT.

Voltage isolation of the input circuit (low-voltage) and output circuit (high-voltage) is imperative in the presence of higher reverse voltages. The output circuit is connected directly to the high-voltage IGBT, while the input circuit provides the interface to the control electronics (Figure 1). Figure 2 shows a 2-channel IGBT driver board with optical control.

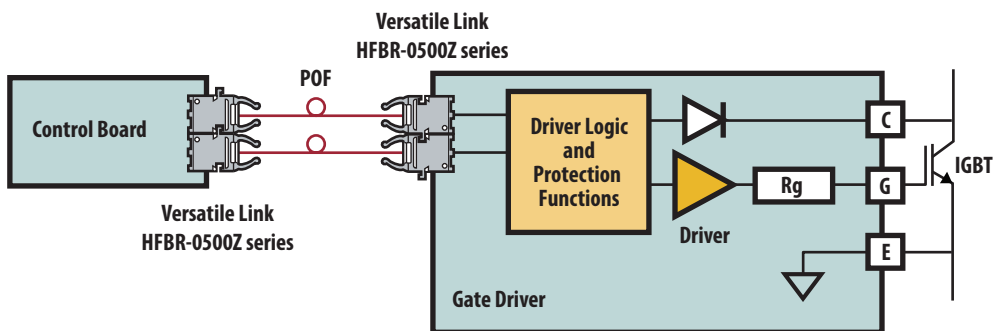

Figure 1. IGBT Gate Driver Block Diagram

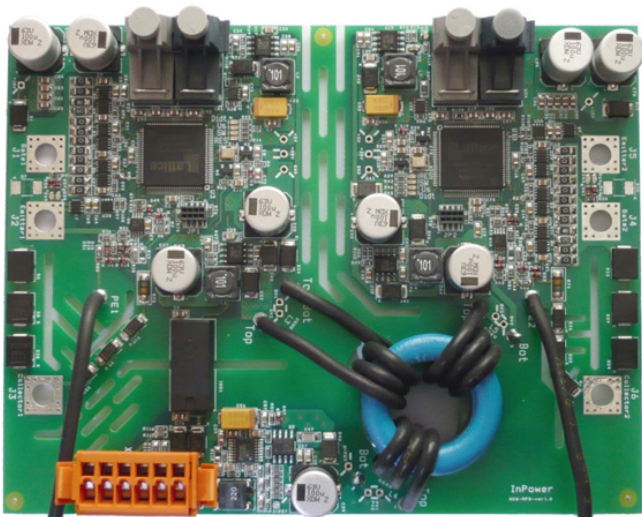

Figure 2. IGBT Driver board from InPower Systems GmbH

## Electrically isolated control of IGBTs

In nearly all IGBT applications, electrical isolation between the control signal and the driver circuit is essential. There are three possibilities for transmitting the electrically isolated control signals and feedback signal (error signal):

- Inductive coupling
- Capacitive coupling
- Optical coupling

While the capacitive solution is rarely used, the inductive coupling and optical coupling solutions are widely used. Optical couplers are frequently used in the case of small to medium voltages, while transformers and optical fiber are used at higher reverse voltages (> 1200 V). Since there is no way in the case of optical signal transmission to transmit sufficient power for the control electronics and IGBT control, a transformer solution is almost always used for power transmission. Thus, transformers are used to transfer the control and feedback signals especially in the mid to high voltage range. In theory, this solution is also applicable even at higher voltages, but as the voltage increases, so does the space requirements of the transformer so that the minimum clearance and creepage distances are still respected.

In the case of higher reverse voltages (> 1200 V), optical transmission can, therefore, prove its advantages. As can be seen in Figure 3, according to the IEC 664-1:1992 standard, at higher voltages, a minimum distance of several centimeters is specified. Such distances are very short links for a fiber-coupling. However, inductive coupling or even capacitive coupling can already represent considerable outlay and require huge space on the board. The advantages and disadvantages of each solution are summarized again in Table 1.

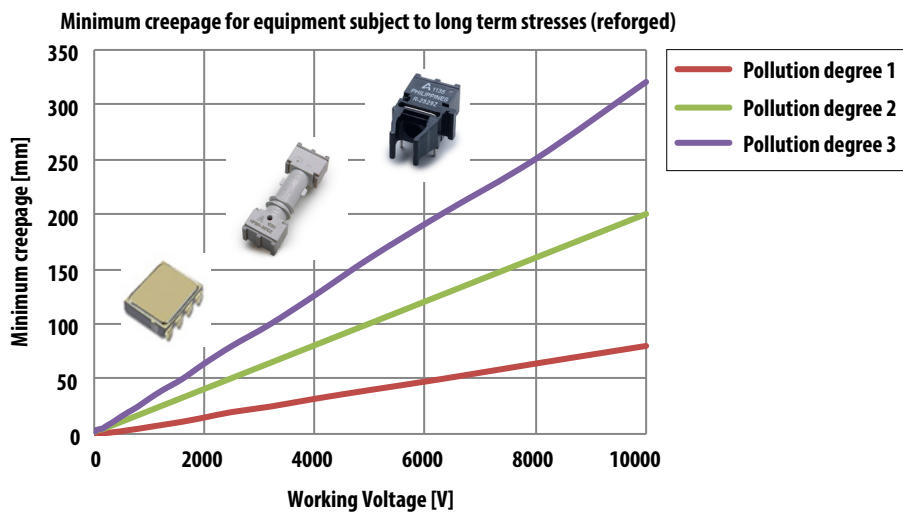

Figure 3. Minimum creepage distance by IEC 60664-1:2002

**Table 1. Galvanic isolation methods**

Concept	Advantage	Disadvantage	Voltage Range
Monolithic level shifters	<ul style="list-style-type: none"> <li>- Costs</li> <li>- Easy integration of additional functions</li> </ul>	<ul style="list-style-type: none"> <li>- No galvanic isolation</li> <li>- No energy transfer</li> </ul>	Up to 600V
Pulse transformers	<ul style="list-style-type: none"> <li>- High insulation</li> <li>- Energy transfer possible</li> </ul>	<ul style="list-style-type: none"> <li>- Required significant amount of space in PCB</li> <li>- Only suitable for transferring AC signals</li> </ul>	Up to 1200V
Coreless transformers	<ul style="list-style-type: none"> <li>- Costs</li> <li>- Easy integration of additional functions</li> </ul>	<ul style="list-style-type: none"> <li>- No energy transfer</li> <li>- Limited insulation voltage</li> </ul>	Up to 1200V
Capacitive couplers	<ul style="list-style-type: none"> <li>- Costs</li> </ul>	<ul style="list-style-type: none"> <li>- High coupling capacity</li> <li>- No energy transfer</li> </ul>	Unusual for IGBT drivers
Optocouplers	<ul style="list-style-type: none"> <li>- Cost</li> <li>- Integrated gate driver possible</li> <li>- Suitable for transferring both AC and DC signals</li> </ul>	<ul style="list-style-type: none"> <li>- No energy transfer</li> </ul>	Up to 1200 V
Fiber optics	<ul style="list-style-type: none"> <li>- Inherent good insulation</li> <li>- Very high EMI immunity</li> <li>- No coupling capacity</li> <li>- Suitable for transferring both AC and DC signals</li> </ul>	<ul style="list-style-type: none"> <li>- No energy transfer</li> </ul>	Middle and high Voltage

### Fiber Optic

In high-voltage systems, an optical fiber connection is usually used for transmitting the control signals and the status and error signals. The clear advantage compared to all other isolation technologies is the theoretically infinite isolation that can be achieved over a realizable distance. Technically, by using multi-mode fiber (MM) or single-mode fiber (SM) and wavelengths of 850nm or 1310nm, transmission over several kilometers presents no problem. But much more frequently, it is required to transmit only a few feet or even inches, and here the transfer of a polymer optical fiber (POF) and a wavelength of 650nm, has been proven to be optimal. The use of POF provides not only a cost-effective solution, but also the handling and preparation of the cable is easier with POF than in the case of MM and SM fiber.

A further advantage of transmission using fiber is that the optical transmission path is completely immune to electro-magnetic radiation. Therefore, there is no problem at all if the fiber is laid in the vicinity of strong electro-magnetic radiating components, as are common in industrial environments.

If the required isolation voltages are of only a few thousand volts, a short link can also be used as an alternative. These devices offer the advantages of an optical fiber connection but can be fitted directly on the board and do not require any assembly. The clearances here are mechanically dictated. An example of such a short link is the HFBR-3810Z from AVAGO Technology as can be seen in Figure 4.

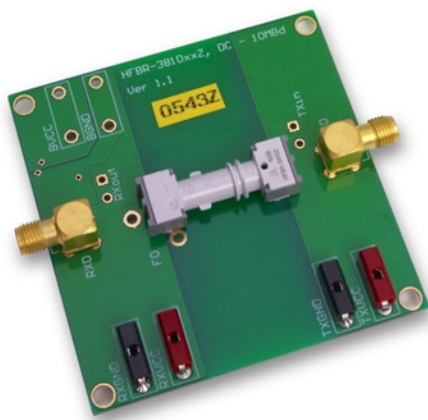

**Figure 4. HFBR-3810Z Optical Short-Link**

## Implementing an Optical Link

Nowadays, the integration of an optical link in its own circuit is not a big problem. As seen in Figure 5, only a few components are needed to control an optical transmitter and an optical receiver properly. In modern components such as the new DC-50Mbd series from AVAGO Technology (Figure 6), even external wiring is no longer necessary. In this series, the drivers are already integrated into the component, enabling it to connect directly to the digital inputs and outputs of a microcontroller, FPGA or other preferred digital circuit. In addition, these components support direct control with 5V and 3.3V signal level, which thus avoids the signal conversion previously required.

Furthermore, all of these components are available in a version with an extended temperature range (-40 ° to 85 °C). This allows use without problem in thermally harsh environments, such as often occur in IGBT applications.

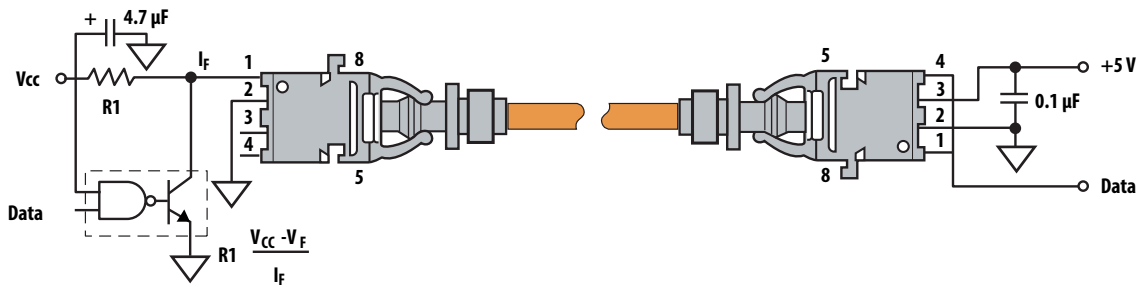

Figure 5. HFBR-1521/2521Z Circuit Diagram for 5MBd Data Rate

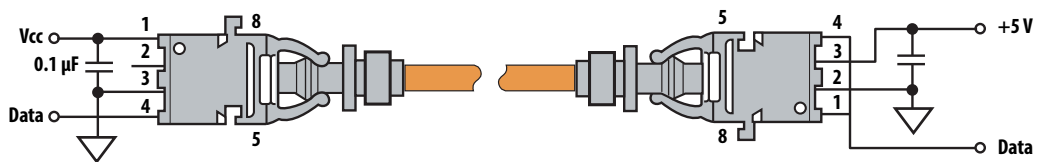

Figure 6. HFBR-1629/2529Z Circuit Diagram for 50MBd Data Rate

## Avago related products

Connector Configuration	Data Rate	Reach		Supply Voltage	Part Number		Application Notes	Evaluation Board
		POF	PCS		Transmitter	Receiver		
	DC-1MBd	10m		5V	HFBR-1524Z	HFBR-2524Z	AN5374	
		45m		5V	HFBR-1522Z	HFBR-2522Z	AN1035	HFBR-0502Z
		45m		5V	HFBR-1522ETZ	HFBR-2522ETZ		
	DC-5MBd	20m		5V	HFBR-1521Z	HFBR-2521Z	AN1035	HFBR-0501Z
		20m		5V		HFBR-2521ETZ		
	DC-10MBd	40m	200m	3.3V/5V	AFBR-1529Z	AFBR-2529Z		
	DC-50MBd	50m	120m	3.3V/5V	AFBR-1624Z	AFBR-2624Z		AFBR-0546Z AFBR-0548Z
50m		120m	3.3V/5V	AFBR-1629Z	AFBR-2529Z		AFBR-0547Z	
Vertical 	DC-1MBd	10m		5V	HFBR-1534Z	HFBR-2534Z	AN5374	
		45m		5V	HFBR-1532Z	HFBR-2532Z	AN1035	HFBR-0502Z
	DC-5MBd	20m		5V	HFBR-1531Z	HFBR-2531Z	AN1035	HFBR-0501Z
		20m		5V	HFBR-1531ETZ	HFBR-2531ETZ	AN1035	
Tilted 	DC-1MBd	45m		5V	HFBR-1542ETZ	HFBR-2542ETZ	AN1035	HFBR-0502Z
	DC-5MBd	20m		5V	HFBR-1541ETZ	HFBR-2541ETZ	AN1035	HFBR-0501Z
	DC-50MBd	50m	120m	3.3V/5V	AFBR-1644Z	AFBR-2644Z		AFBR-0546Z AFBR-0548Z
FO Short Link 	DC-10MBd	24.96mm Creepage & Clearance		5V	HFBR-3810Z & HFBR-3810MSZ			HFBR-0543Z

**References:**

AV02-3407EN – AFBR-1624Z/1629Z and AFBR-2624Z/2529Z – Data Sheet

AV02-2699EN – HFBR-0500ETZ – Data Sheet

IEC60664-1 Standard

AV02-3500EN – Fiber versus Copper Links – White Paper

IGBT Modules – Technologies, Driver and Application / Andreas Volke, Michael Hornkamp;

ISBN 978-3-00-032076-7 Infineon Technologies AG Munich

For product information and a complete list of distributors, please go to our web site: [www.avagotech.com](http://www.avagotech.com)

Avago, Avago Technologies, and the A logo are trademarks of Avago Technologies in the United States and other countries.  
Data subject to change. Copyright © 2005-2013 Avago Technologies. All rights reserved.

AV02-4115EN - May 30, 2013

