

ACPL-M484/P484/W484

Positive Logic High CMR Intelligent Power Module and Gate Drive Interface Optocoupler

Overview

The Broadcom[®] ACPL-M484/P484/W484 fast-speed optocoupler contains a AlGaAs LED and photo detector with built-in Schmitt trigger to provide logic-compatible waveforms, eliminating the need for additional wave shaping. The totem pole output eliminates the need for a pull-up resistor and allows for direct drive Intelligent Power Module or gate drive. Minimized propagation delay difference between devices makes these optocouplers excellent solutions for improving inverter efficiency through reduced switching dead time.

Specifications

- Wide operating temperature range: -40°C to $+105^{\circ}\text{C}$
- Maximum propagation delay $t_{\text{PHL}}/t_{\text{PLH}} = 150\text{ ns}/120\text{ ns}$
- Maximum pulse width distortion (PWD) = 90 ns
- Propagation delay difference: Min./Max. = $-130\text{ ns}/+130\text{ ns}$
- Wide operating V_{CC} range: 4.5V to 30V
- 30 kV/ μs Minimum common mode rejection (CMR) at $V_{\text{CM}} = 1000\text{V}$

Features

- Positive output type (totem pole output)
- Truth table guaranteed: V_{CC} from 4.5V to 30V
- Performance specified for common IPM applications over industrial temperature range
- Short maximum propagation delays
- Minimized pulse width distortion (PWD)
- Very high common mode rejection (CMR)
- Hysteresis
- Available in SO-5 (ACPL-M484) and Stretched SO-6 package (ACPL-P484/W484)
- Package clearance/creepage at 8 mm (ACPL-W484)
- Safety approval:
 - UL recognized with $5000V_{\text{RMS}}$ (ACPL-W484) for 1 minute per UL1577.
 - CSA approved.
 - IEC/EN/DIN EN 60747-5-5 approved with $V_{\text{IORM}} = 567 V_{\text{peak}}$ for ACPL-M484 and $V_{\text{IORM}} = 891 V_{\text{peak}}$ for ACPL-P484 and $V_{\text{IORM}} = 1140 V_{\text{peak}}$ for ACPL-W484, under option 060.

Applications

- IPM interface isolation
- Isolated IGBT/MOSFET gate drive
- AC and brushless DC motor drives
- Industrial inverters
- General digital isolation

CAUTION! Take normal static precautions in handling and assembly of this component to prevent damage and/or degradation that might be induced by electrostatic discharge (ESD). The components featured in this data sheet are not to be used in military or aerospace applications or environments.

Functional Diagram

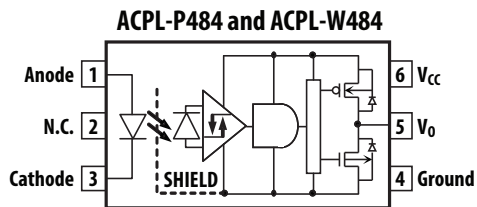
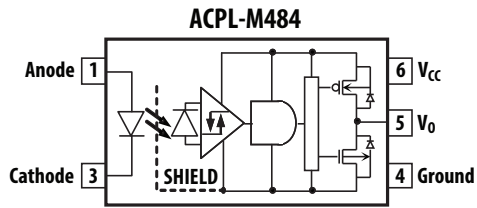

NOTE: A 0.1- μF bypass capacitor must be connected between pins 4 and 6. Truth Table guaranteed: V_{CC} from 4.5V to 30V.

Truth Table (Non-Inverting Logic)

LED	V_O
ON	HIGH
OFF	LOW

Ordering Information

The ACPL-M484/P484/W484 is UL recognized with 3750/3750/5000 V_{RMS} /1 minute rating per UL 1577, respectively.

Part Number	Option	Package	Surface Mount	Tape and Reel	IEC/EN/DIN EN 60747-5-5	Quantity
	RoHS Compliant					
ACPL-M484	-000E	Stretched SO-5	X			100 per tube
	-500E		X	X		1500 per reel
	-060E		X		X	100 per tube
	-560E		X	X	X	1500 per reel
ACPL-P484	-000E	Stretched SO-6	X			100 per tube
ACPL-W484	-500E		X	X		1000 per reel
	-060E		X		X	100 per tube
	-560E		X	X	X	1000 per reel

To order, choose a part number from the part number column and combine with the desired option from the option column to form an ordering part number.

- **Example 1:** ACPL-P484-560E: Stretched SO-6 surface-mount package in tape and reel packaging with IEC/EN/DIN EN 60747-5-5 safety approval and RoHS compliant.
- **Example 2:** ACPL-P484-000E to order product of stretched SO-6 surface-mount package in tube packaging and RoHS compliant.
- **Example 3:** ACPL-M484-000E to order product of SO-5 surface-mount package in tube packaging and RoHS compliant.

Option data sheets are available. Contact your Broadcom sales representative or authorized distributor for information.

Recommended Pb-Free IR Profile

The recommended reflow profile is per JEDEC Standard, J-STD-020 (latest revision). Non-halide flux should be used.

Regulatory Information

The ACPL-M484/P484/W484 is approved by the following organizations:

- IEC/EN/DIN EN 60747-5-5 (Option 060 only): Approved with maximum working insulation voltage $V_{IORM} = 567 V_{peak}$ for ACPL-M484, $V_{IORM} = 891 V_{peak}$ for ACPL-P484, and $V_{IORM} = 1140 V_{peak}$ for ACPL-W484.
- UL: Approval under UL 1577, component recognition program up to VISO = 3750 V_{RMS} File E55361 for ACPL-M484 and ACPL-P484. Approval under UL 1577, component recognition program up to VISO = 5000 V_{RMS} File E55361 for ACPL-W484.
- CSA: Approval under CSA Component Acceptance Notice #5, File CA 88324.

Package Outline Drawings

ACPL-M484 SO-5 Package (5 mm Creepage and Clearance)

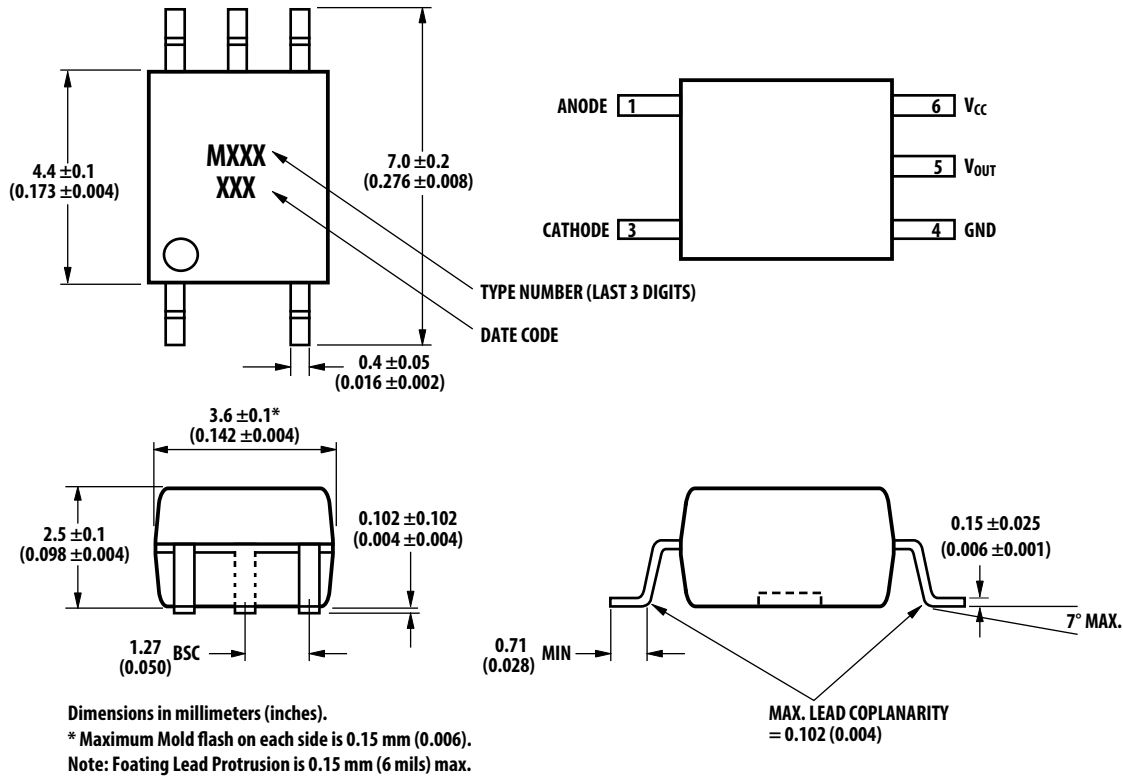

ACPL-M484 Land Pattern Recommendation

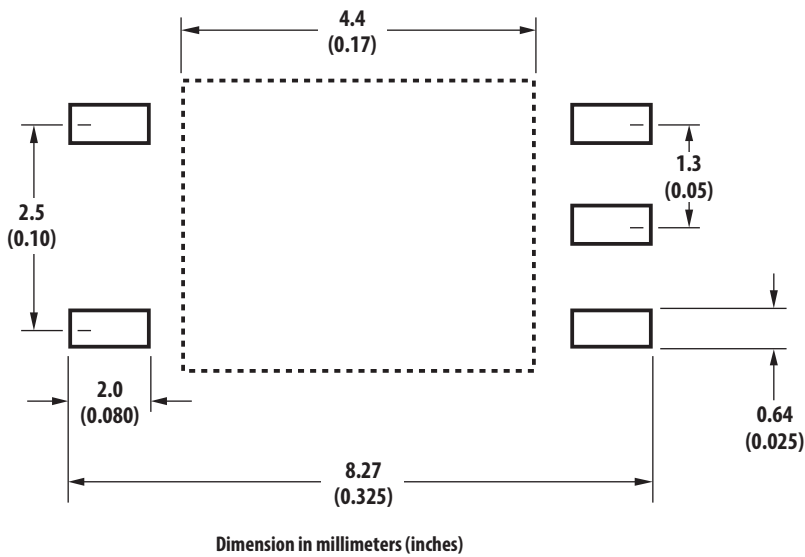

ACPL-P484 Stretched SO-6 Package (7-mm Clearance) with Land Pattern Recommendation

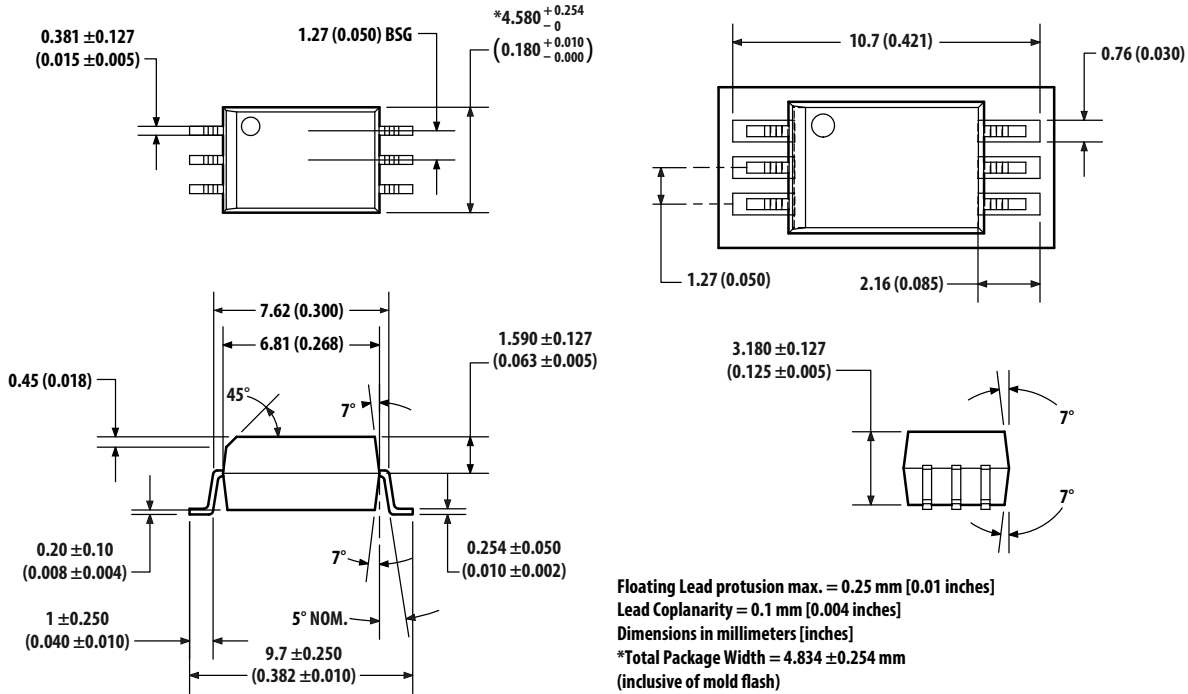

ACPL-W484 Stretched SO-6 Package (8-mm Clearance) with Land Pattern Recommendation

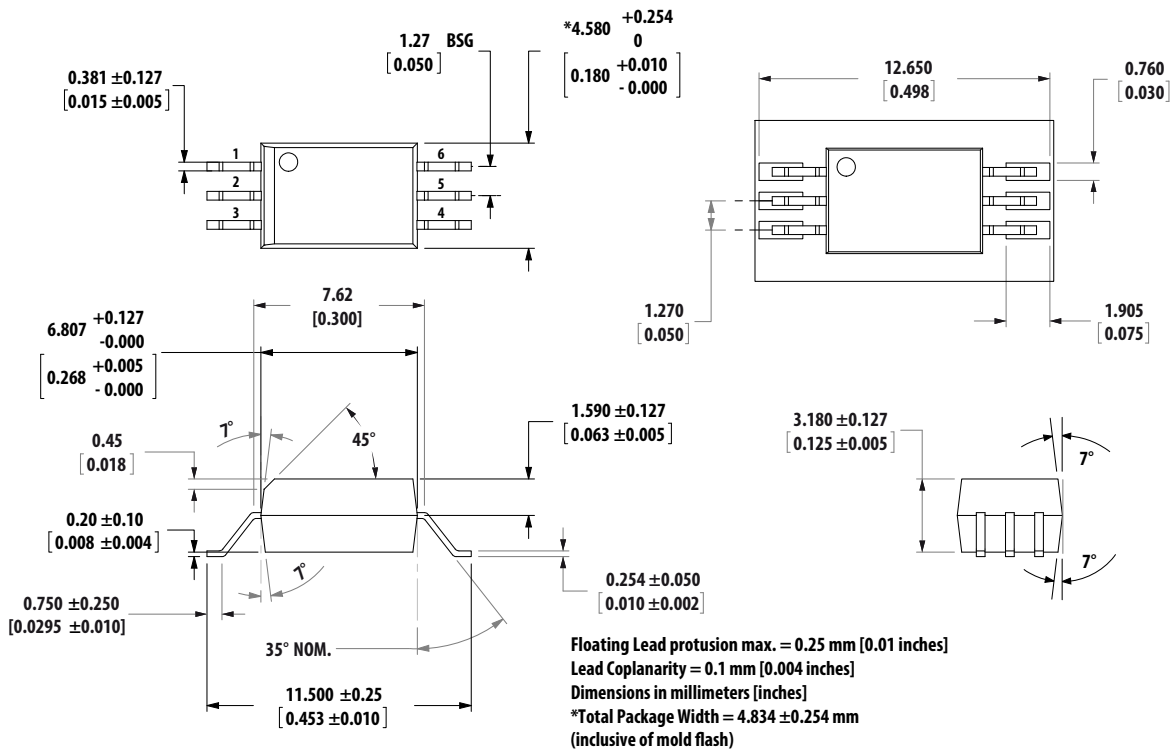

IEC/EN/DIN EN 60747-5-5 Insulation Characteristics (Option 060)

Description	Symbol	ACPL-M484	ACPL-P484	ACPL-W484	Unit
Installation classification per DIN VDE 0110/1.89, Table 1 For Rated Mains Voltage $\leq 150 V_{RMS}$ For Rated Mains Voltage $\leq 300 V_{RMS}$ For Rated Mains Voltage $\leq 600 V_{RMS}$		I – IV I – III I – II	I – IV I – III I – II	I – IV I – III I – II	
Climatic Classification		55/100/21			
Pollution Degree (DIN VDE 0110/1.89)		2			
Maximum Working Insulation Voltage	V_{IORM}	567	891	1140	V_{peak}
Input to Output Test Voltage, Method b ^a $V_{IORM} \times 1.875 = V_{PR}$, 100% Production Test with $t_m = 1$ second, Partial Discharge < 5 pC	V_{PR}	1063	1670	2137	V_{peak}
Input to Output Test Voltage, Method a ^a $V_{IORM} \times 1.6 = V_{PR}$, Type and Sample Test, $t_m = 10$ seconds, Partial Discharge < 5 pC	V_{PR}	907	1426	1824	V_{peak}
Highest Allowable Overvoltage (Transient Overvoltage $t_{ini} = 60$ seconds)	V_{IOTM}	6000	6000	8000	V_{peak}
Safety-Limiting Values (Maximum values allowed in the event of a failure)					
Case Temperature	T_S	175			$^{\circ}C$
Input Current	$I_{S, INPUT}$	230			mA
Output Power	$P_{S, OUTPUT}$	600			mW
Insulation Resistance at T_S , $V_{IO} = 500V$	R_S	$>10^9$			Ω

a. Refer to the optocoupler section of the Isolation and Control Components Designer's Catalog, under the Product Safety Regulations section, (IEC/EN/DIN EN 60747-5-5), for a detailed description of Method a and Method b partial discharge test profiles.

Insulation and Safety Related Specifications

Parameter	Symbol	ACPL-M484	ACPL-P484	ACPL-W484	Unit	Condition
Minimum External Air Gap (External Clearance)	L(101)	5.0	7.0	8.0	mm	Measured from input terminals to output terminals, shortest distance through air.
Minimum External Tracking (External Creepage)	L(102)	5.0	8.0	8.0	mm	Measured from input terminals to output terminals, shortest distance path along body.
Minimum Internal Plastic Gap (Internal Clearance)		0.08			mm	Through insulation distance conductor to conductor, usually the straight line distance thickness between the emitter and detector.
Tracking Resistance (Comparative Tracking Index)	CTI	>175			V	DIN IEC 112/VDE 0303 Part 1.
Isolation Group		IIIa				Material Group (DIN VDE 0110, 1/89, Table 1).

Absolute Maximum Ratings

Parameter	Symbol	Min.	Max.	Unit	Note
Storage Temperature	T_S	-55	+125	°C	
Operating Temperature	T_A	-40	+105	°C	
Average Input Current	$I_{F(AVG)}$	—	10	mA	
Peak Transient Input Current <1 μ s Pulse Width, 300 pps <200 μ s Pulse Width, <1% Duty Cycle	$I_{F(TRAN)}$	—	1.0 40	A mA	
Reverse Input Voltage	V_R	—	5	V	
Average Output Current	I_O	—	50	mA	
Supply Voltage	V_{CC}	0	35	V	
Output Voltage	V_O	-0.5	35	V	
Total Package Power Dissipation (ACPL-M484)	P_T	—	145	mW	a
Total Package Power Dissipation	P_T	—	210	mW	a

a. Derate total package power dissipation, P_T , linearly above 70°C free-air temperature at a rate of 4.5 mW/°C (ACPL-P484/W484) and linearly above 85°C free-air temperature at a rate of 0.75 mW/°C (ACPL-M484).

Recommended Operating Conditions

Parameter	Symbol	Min.	Max.	Unit	Note
Power Supply Voltage ^a	V_{CC}	4.5	30	V	b
Forward Input Current (ON)	$I_{F(ON)}$	4	7	mA	
Forward Input Voltage (OFF)	$V_{F(OFF)}$	—	0.8	V	
Operating Temperature	T_A	-40	+105	°C	

a. Truth Table guaranteed: 4.5V to 30V.

b. Detector requires a V_{CC} of 4.5V or higher for stable operation as output might be unstable if V_{CC} is lower than 4.5V. Be sure to check the power ON/OFF operation other than the supply current.

Electrical Specifications

Over recommended operating conditions $T_A = -40^\circ\text{C}$ to $+105^\circ\text{C}$, $V_{CC} = 4.5\text{V}$ to 30V , $I_{F(ON)} = 4\text{ mA}$ to 7 mA , $V_{F(OFF)} = 0\text{V}$ to 0.8V , unless otherwise specified. All typicals at $T_A = 25^\circ\text{C}$.

Parameter	Symbol	Min.	Typ.	Max.	Unit	Test Conditions	Fig.	Note
Logic Low Output Voltage	V_{OL}	—	—	0.3	V	$I_{OL} = 3.5\text{ mA}$	1, 3	
		—	—	0.5		$I_{OL} = 6.5\text{ mA}$		
Logic High Output Voltage	V_{OH}	$V_{CC} - 0.3$	$V_{CC} - 0.04$	—	V	$I_{OH} = -3.5\text{ mA}$	2, 3, 7	
		$V_{CC} - 0.5$	$V_{CC} - 0.07$	—		$I_{OH} = -6.5\text{ mA}$		
Logic Low Supply Current	I_{CCL}	—	1.5	3.0	mA	$V_{CC} = 5.5\text{V}$, $V_F = 0\text{V}$, $I_O = 0\text{ mA}$		
		—	1.7	3.0	mA	$V_{CC} = 20\text{V}$, $V_F = 0\text{V}$, $I_O = 0\text{ mA}$		
Logic High Supply Current	I_{CCH}	—	1.5	3.0	mA	$V_{CC} = 5.5\text{V}$, $I_F = 7\text{ mA}$, $I_O = 0\text{ mA}$		
		—	1.7	3.0	mA	$V_{CC} = 30\text{V}$, $I_F = 7\text{ mA}$, $I_O = 0\text{ mA}$		
Threshold Input Current Low to High	I_{FLH}		0.8	2.2	mA			
Threshold Input Voltage High to Low	V_{FHL}	0.8	—	—	V	$I_F = 4\text{ mA}$		
Logic Low Short Circuit Output Current	I_{OSL}	125	200	—	mA	$V_O = V_{CC} = 5.5\text{V}$, $V_F = 0\text{V}$		a
		125	200	—	mA	$V_O = V_{CC} = 30\text{V}$, $V_F = 0\text{V}$		
Logic High Short Circuit Output Current	I_{OSH}	—	-200	-125	mA	$V_{CC} = 5.5\text{V}$, $I_F = 7\text{ mA}$, $V_O = \text{GND}$		a
		—	-200	-125	mA	$V_{CC} = 20\text{V}$, $I_F = 7\text{ mA}$, $V_O = \text{GND}$		
Input Forward Voltage	V_F	1.3	1.5	1.7	V	$T_A = 25^\circ\text{C}$, $I_F = 4\text{ mA}$	4	
		—	—	1.85	V	$I_F = 4\text{ mA}$		
Input Reverse Breakdown Voltage	BV_R	5	—	—	V	$I_R = 10\text{ }\mu\text{A}$		
Input Diode Temperature Coefficient	$\Delta V_F/\Delta T_A$	—	1.7	—	mV/ $^\circ\text{C}$	$I_F = 4\text{ mA}$		
Input Capacitance	C_{IN}	—	60	—	pF	$f = 1\text{ MHz}$, $V_F = 0\text{V}$		b

a. Duration of output short circuit time should not exceed 500 μs .

b. Input capacitance is measured between pin 1 and pin 3.

Switching Specifications

Over recommended operating conditions $T_A = -40^\circ\text{C}$ to $+105^\circ\text{C}$, $V_{CC} = 4.5\text{V}$ to 30V , $I_{F(ON)} = 4\text{ mA}$ to 7 mA , $V_{F(OFF)} = 0\text{V}$ to 0.8V , unless otherwise specified. All typicals at $T_A = 25^\circ\text{C}$.

Parameter	Symbol	Min.	Typ.	Max.	Unit	Test Conditions	Fig.	Note
Propagation Delay Time to Logic Low Output Level	t_{PHL}	—	95	150	ns	$C_L = 100\text{ pF}$, $I_{F(ON)} = 4\text{ mA} \rightarrow$ $V_F = 0\text{V}$	5, 6, 8	a
		—	—	150		Loaded as per Figure 5		
Propagation Delay Time to Logic High Output Level	t_{PLH}	—	85	120	ns	$C_L = 100\text{ pF}$, $V_F = 0\text{V} \rightarrow$ $I_{F(ON)} = 4\text{ mA}$	5, 6, 8	a
		—	—	120		Loaded as per Figure 5		
Pulse Width Distortion	$ t_{PHL} - t_{PLH} =$ PWD	—	—	90	ns	$C_L = 100\text{ pF}$		b
		—	—	90		Loaded as per Figure 5		
Propagation Delay Difference Between Any Two Parts	PDD	-130	—	130	ns	$C_L = 100\text{ pF}$		c
		-130	—	130		Loaded as per Figure 5		
Output Rise Time (10% to 90%)	t_r	—	6	—	ns		5	
Output Fall Time (90% to 10%)	t_f	—	6	—	ns		5	
Logic High Common Mode Transient Immunity	$ CM_H $	30	—	—	kV/ μs	$ V_{CM} = 1000\text{V}$, $I_F = 4.0\text{ mA}$, $V_{CC} = 5\text{V}$, $T_A = 25^\circ\text{C}$	9	d
Logic Low Common Mode Transient Immunity	$ CM_L $	30	—	—	kV/ μs	$ V_{CM} = 1000\text{V}$, $V_F = 0\text{V}$, $V_{CC} = 5\text{V}$, $T_A = 25^\circ\text{C}$	9	d

- The t_{PLH} propagation delay is measured from the 50% point on the leading edge of the input pulse to the 1.3V point on the leading edge of the output pulse. The t_{PHL} propagation delay is measured from the 50% point on the trailing edge of the input pulse to the 1.3 V point on the trailing edge of the output pulse
- Pulse width distortion (PWD) is defined as $|t_{PHL} - t_{PLH}|$ for any given device.
- The difference of t_{PLH} and t_{PHL} between any two devices under the same test condition.
- CM_H is the maximum slew rate of the common mode voltage that can be sustained with the output voltage in the logic high state, $V_O > 2.0\text{V}$. CM_L is the maximum slew rate of the common mode voltage that can be sustained with the output voltage in the logic low state, $V_O < 0.8\text{V}$. Note: Equal value split resistors ($R_{in}/2$) must be used at both ends of the LED.

Package Characteristics

Parameter	Symbol	Min.	Typ.	Max.	Unit	Test Conditions	Note
Input-Output Momentary Withstand Voltage ^a	V_{ISO}	3750 (ACPL-M484/P484) 5000 (ACPL-W484)	—	—	V_{RMS}	$RH < 50\%$, $t = 1\text{ minute}$, $T_A = 25^\circ\text{C}$	b, c
Input-Output Resistance	R_{I-O}	—	10^{12}	—	Ω	$V_{I-O} = 500\text{ V}_{DC}$	b
Input-Output Capacitance	C_{I-O}	—	0.6	—	pF	$f = 1\text{ MHz}$, $V_{I-O} = 0\text{ V}_{DC}$	b

- The Input-Output Momentary Withstand Voltage is a dielectric voltage rating that should not be interpreted as an input-output continuous voltage rating. For the continuous voltage rating, refer to the IEC/EN/DIN EN 60747-5-5 Insulation Characteristics Table (if applicable).
- Device considered a two-terminal device: pins 1, 2, and 3 shorted together and pins 4, 5, and 6 shorted together.
- In accordance with UL 1577, each optocoupler is proof tested by applying an insulation test voltage. 4500 V_{RMS} for one second (leakage detection current limit, $I_{I-O} \leq 5\text{ }\mu\text{A}$). This test is performed before the 100% production test for partial discharge (Method b) shown in [IEC/EN/DIN EN 60747-5-5 Insulation Characteristics \(Option 060\)](#), if applicable.

Figure 1: Typical Logic Low Output Voltage vs. Temperature

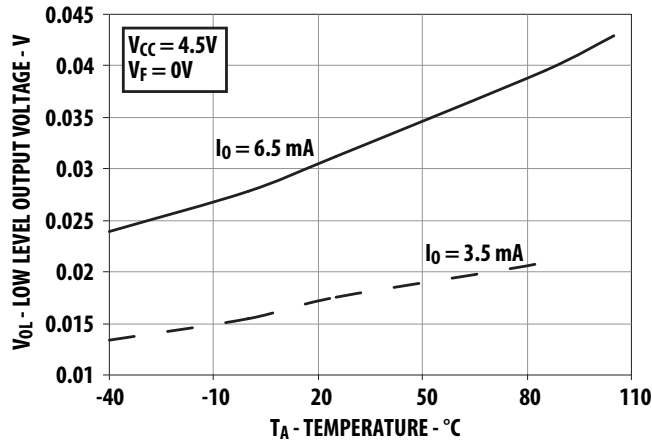

Figure 2: Typical Logic High Output Current vs. Temperature

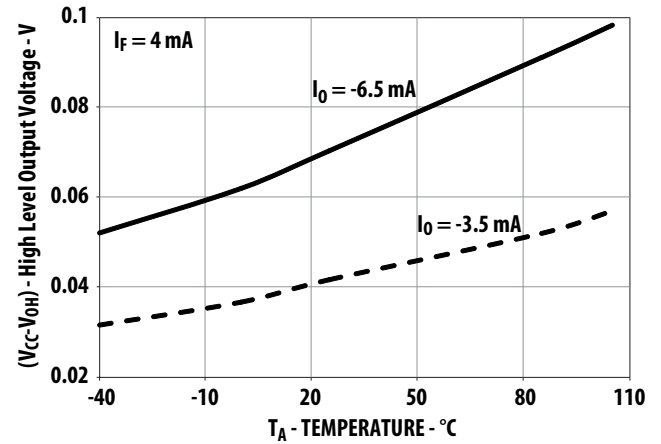

Figure 3: Typical Output Voltage vs. Forward Input Current

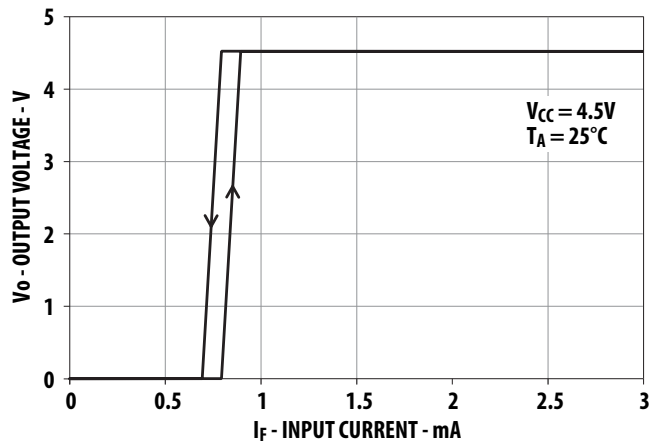

Figure 4: Typical Input Diode Forward Characteristic

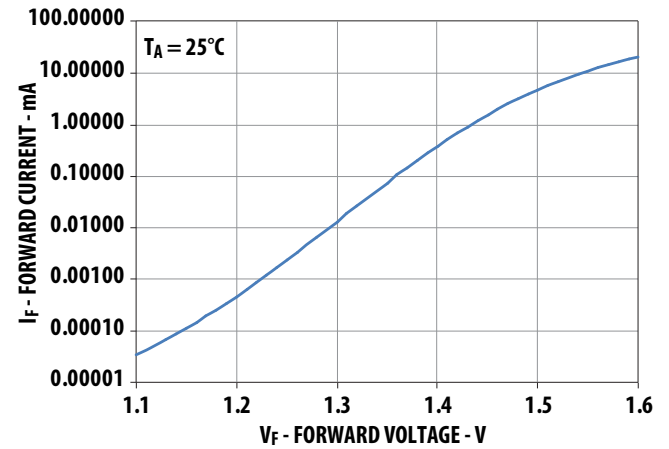
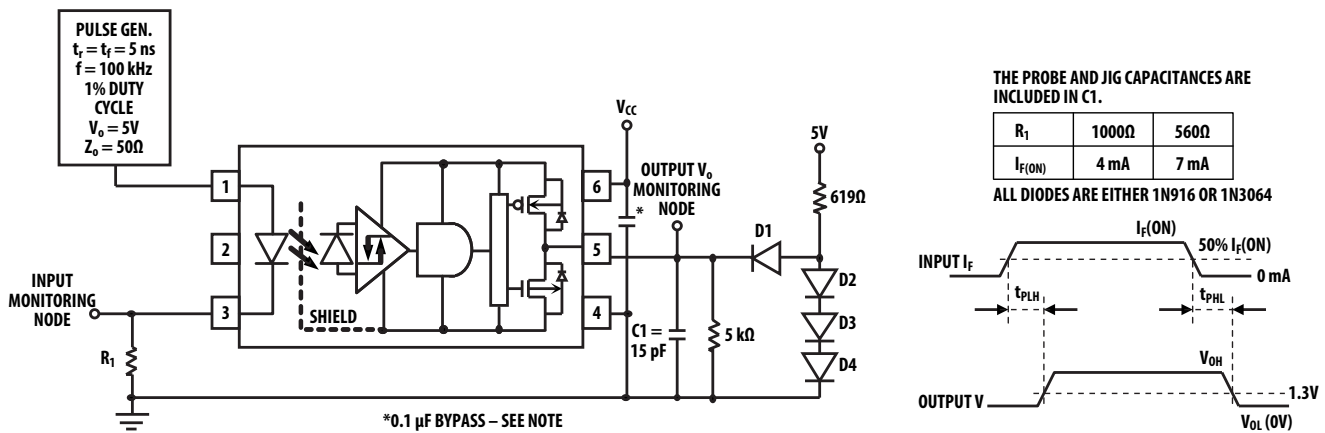

Figure 5: Test Circuit for t_{PLH} , t_{PHL} , t_r , and t_f



Note: Use of a 0.1-μF bypass capacitor connected between pins V_{CC} and Ground is recommended.

Figure 6: Typical Propagation Delays vs. Temperature

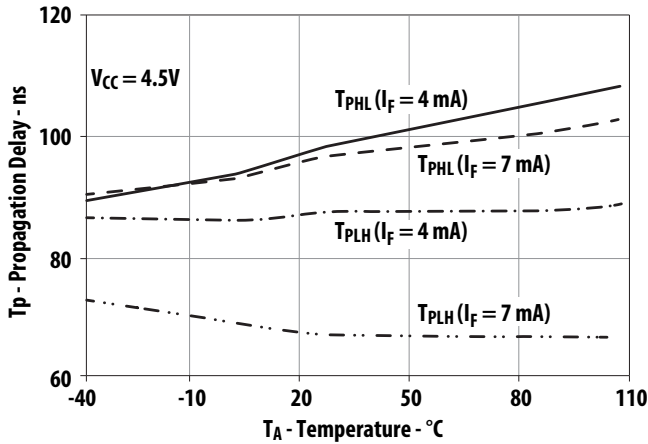

Figure 7: Typical Logic High Output Voltage vs. Supply Voltage

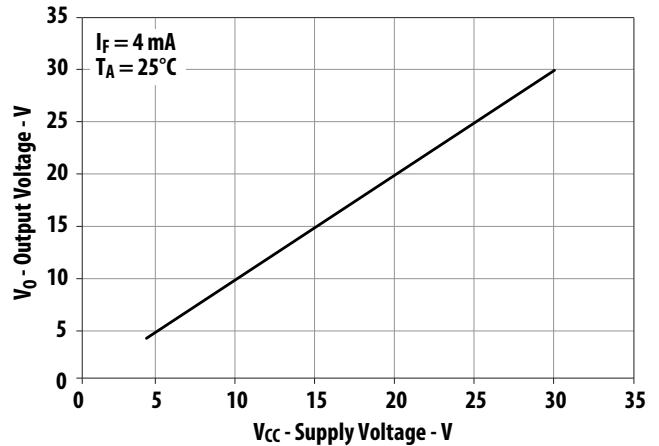

Figure 8: Typical Propagation Delay vs. Supply Voltage

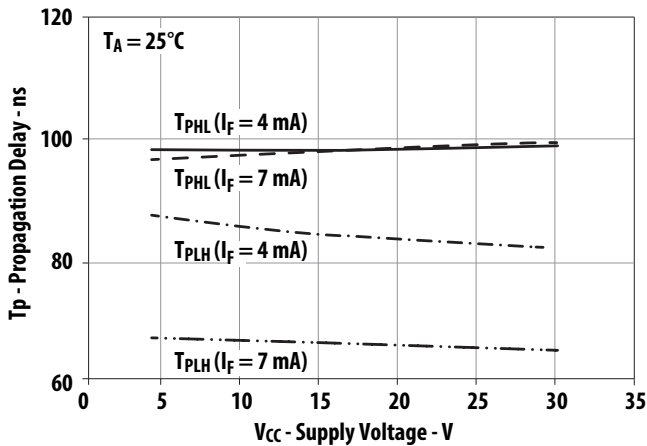
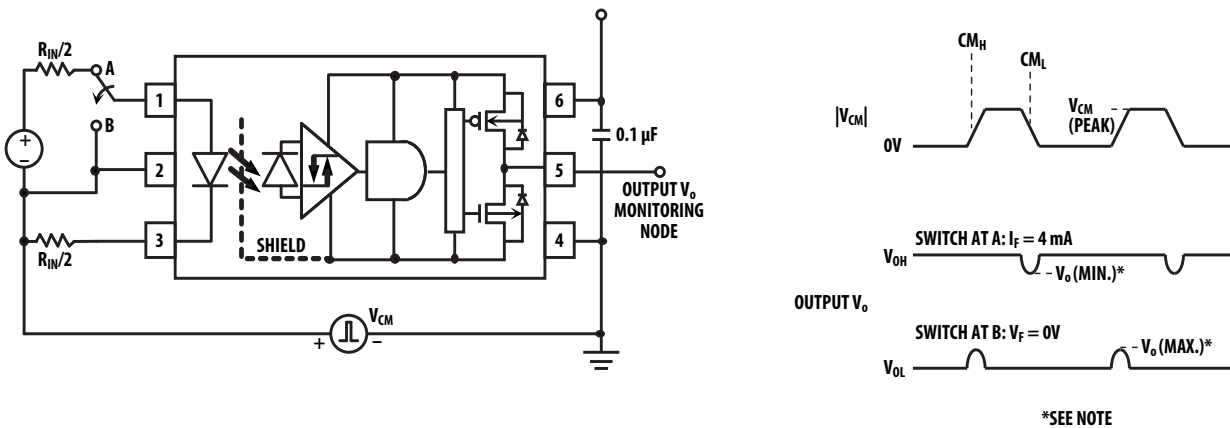

Figure 9: Test Circuit for Common Mode Transient Immunity and Typical Waveforms



Note: CM_H is the maximum slew rate of the common mode voltage that can be sustained with the output voltage in the logic high state, $V_O > 2.0V$. CM_L is the maximum slew rate of the common mode voltage that can be sustained with the output voltage in the logic low state, $V_O < 0.8V$. Note: Equal value split resistors ($R_{in}/2$) must be used at both ends of the LED.

Under-Voltage Lockout (UVLO)

Figure 10 and Figure 11 show typical output waveforms during power-up and power-down processes.

Figure 10: V_{CC} Ramp When LED ON

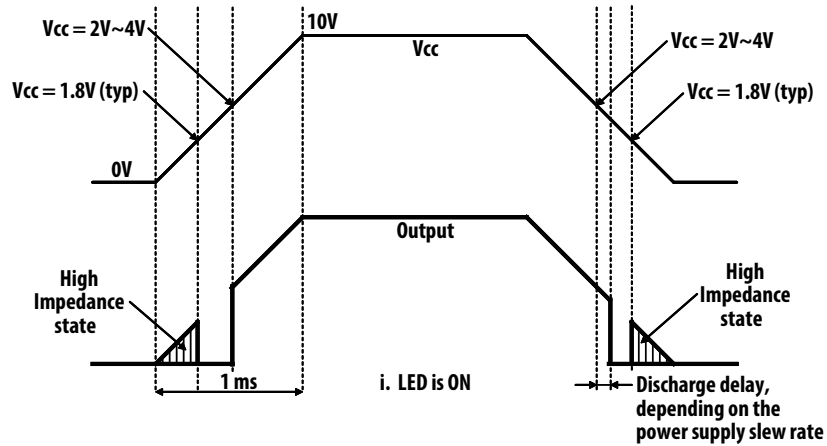
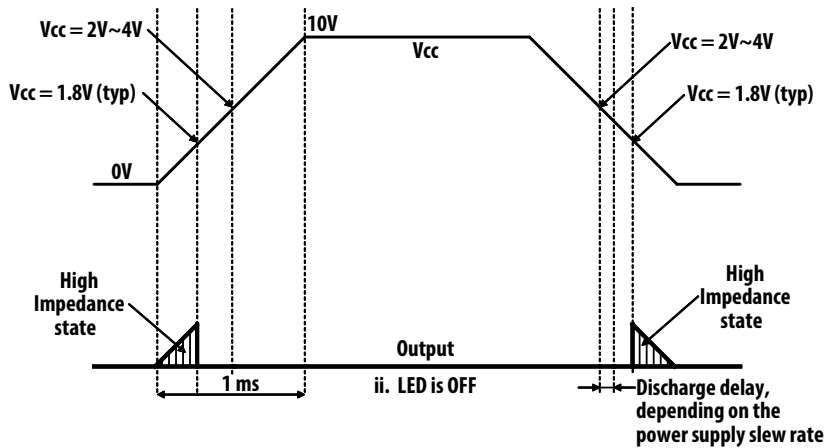

Figure 11: V_{CC} Ramp When LED OFF



Thermal Model for ACPL-M484 SO-5 Package Optocoupler

Definitions:

- R_{11} : Junction to ambient thermal resistance of LED due to heating of LED.
- R_{12} : Junction to ambient thermal resistance of LED due to heating of Detector (Output IC).
- R_{21} : Junction to ambient thermal resistance of Detector (Output IC) due to heating of LED.
- R_{22} : Junction to ambient thermal resistance of Detector (Output IC) due to heating of detector (Output IC).
- P_1 : Power dissipation of LED (W).
- P_2 : Power dissipation of Detector/Output IC (W).
- T_1 : Junction temperature of LED (°C).
- T_2 : Junction temperature of Detector (°C).
- T_a : Ambient temperature.
- ΔT_1 : Temperature difference between LED junction and ambient (°C).
- ΔT_2 : Temperature difference between Detector junction and ambient.
- Ambient temperature: Junction to ambient thermal resistances were measured approximately 1.25 cm above optocoupler at ~23°C in still air.

Description:

This thermal model assumes that an 5-pin single-channel plastic package optocoupler is soldered into a 7.62 cm × 7.62 cm printed circuit board (PCB). The temperature at the LED and Detector junctions of the optocoupler can be calculated using the following equations:

$$T_1 = (R_{11} \times P_1 + R_{12} \times P_2) + T_A \quad (1)$$

$$T_2 = (R_{21} \times P_1 + R_{22} \times P_2) + T_A \quad (2)$$

JEDEC Specifications	R11	R12, R21	R22
Low K board	191	77, 91	99
High K board	126	26, 35	51

NOTE: The maximum junction temperature for the parts in this section is 125°C.

Thermal Model for ACPL-P484/W484 SO-6 Package Optocoupler

Definitions:

- R_{11} : Junction to ambient thermal resistance of LED due to heating of LED.
- R_{12} : Junction to ambient thermal resistance of LED due to heating of Detector (Output IC).
- R_{21} : Junction to ambient thermal resistance of Detector (Output IC) due to heating of LED.
- R_{22} : Junction to ambient thermal resistance of Detector (Output IC) due to heating of detector (Output IC).
- P_1 : Power dissipation of LED (W).
- P_2 : Power dissipation of Detector/Output IC (W).
- T_1 : Junction temperature of LED (°C).
- T_2 : Junction temperature of Detector (°C).
- T_a : Ambient temperature.
- ΔT_1 : Temperature difference between LED junction and ambient (°C).
- ΔT_2 : Temperature difference between Detector junction and ambient.
- Ambient temperature: Junction to ambient thermal resistances were measured approximately 1.25 cm above optocoupler at ~23°C in still air.

Description:

This thermal model assumes that an 6-pin single-channel plastic package optocoupler is soldered into a 7.62 cm × 7.62 cm printed circuit board (PCB). The temperature at the LED and Detector junctions of the optocoupler can be calculated using the following equations:

$$T_1 = (R_{11} \times P_1 + R_{12} \times P_2) + T_A \quad (1)$$

$$T_2 = (R_{21} \times P_1 + R_{22} \times P_2) + T_A \quad (2)$$

JEDEC Specifications	R11	R12, R21	R22
Low K board	167	64, 81	89
High K board	117	31, 39	54

NOTE: The maximum junction temperature for the parts in this section is 125°C.

Copyright © 2017–2024 Broadcom. All Rights Reserved. The term “Broadcom” refers to Broadcom Inc. and/or its subsidiaries. For more information, go to www.broadcom.com. All trademarks, trade names, service marks, and logos referenced herein belong to their respective companies.

Broadcom reserves the right to make changes without further notice to any products or data herein to improve reliability, function, or design. Information furnished by Broadcom is believed to be accurate and reliable. However, Broadcom does not assume any liability arising out of the application or use of this information, nor the application or use of any product or circuit described herein, neither does it convey any license under its patent rights nor the rights of others.

