

HFBR-0507ETZ Series, HFBR-1527ETZ Transmitters, HFBR-2526ETZ Receivers

125-Megabaud Versatile Link Fiber-Optic Connection



Description

The 125-Mbaud Versatile Link (HFBR-0507ETZ Series) is the most cost-effective fiber-optic solution for transmission of 125-Mbaud data over 100 meters. The data link consists of a 650-nm LED transmitter (HFBR-1527ETZ) and a PIN/preamp receiver (HFBR-2526ETZ). These can be used with low-cost plastic or silica fiber. One-mm diameter plastic fiber provides the lowest-cost solution for distances under 25m. The lower attenuation of silica fiber allows data transmission over a longer distance, for a small difference in cost. These components can be used for high-speed data links without the problems common with copper wire solutions, at a competitive cost.

The HFBR-1527ETZ transmitter is a high-power 650-nm LED in a low-cost plastic housing that is designed to efficiently couple power into 1-mm diameter plastic optical fiber and 200- μ m hard clad silica (HCS) fiber. With the recommended drive circuit, the LED operates at speeds from 1 Mbaud to 125 Mbaud. The HFBR-2526ETZ is a high-bandwidth analog receiver that contains a PIN photodiode and internal transimpedance amplifier. With the recommended application circuit for 125-Mbaud operation, the performance of the complete data link is specified from 0m to 25m with plastic fiber and from 0m to 100m with 200- μ m HCS fiber. A wide variety of other digitizing circuits can be combined with the HFBR-0507ETZ Series to optimize performance and cost at higher and lower data rates.

Features

- -40°C to $+85^{\circ}\text{C}$ operating temperature range
- RoHS compliant
- Data transmission at signal rates from 1 Mbaud to 125 Mbaud over distances of 100m
- Compatible with inexpensive, easily terminated plastic optical fiber, and with large core silica fiber
- High voltage isolation
- Transmitter and receiver application circuit schematics and recommended board layouts available
- Interlocking feature for single-channel or duplex links, in a vertical or horizontal mount configuration

Applications

- Intra-system links: board-to-board, rack-to-rack
- Telecommunications switching systems
- Computer-to-peripheral data links, PC bus extension
- Industrial control
- Proprietary LANs
- Renewable energy
- Medical instruments
- Reduction of lightning and voltage transient susceptibility

HFBR-0507ETZ Series

125-Mbaud Data Link

Data link operating conditions and performance are specified for the HFBR-1527ETZ transmitter and HFBR-2526ETZ receiver in the recommended applications circuits shown in [Figure 1](#). This circuit has been optimized for 125-Mbaud operation. For other data rate applications, refer to Application Notes [1121](#), [1122](#), and [1123](#).

Recommended Operating Conditions for the Circuits in [Figures 1 and 2](#)

| Parameter | Symbol | Min. | Max. | Unit | Reference |
|---------------------------|----------|-----------------|-----------------|----------|-------------------|
| Ambient Temperature | T_A | -40 | 85 | °C | — |
| Supply Voltage | V_{CC} | +4.75 | +5.25 | V | — |
| Data Input Voltage – Low | V_{IL} | $V_{CC} - 1.89$ | $V_{CC} - 1.62$ | V | — |
| Data Input Voltage – High | V_{IH} | $V_{CC} - 1.06$ | $V_{CC} - 0.70$ | V | — |
| Data Output Load | R_L | 45 | 55 | Ω | Note ^a |
| Signaling Rate | f_S | 1 | 125 | Mbaud | — |
| Duty Cycle | D.C. | 40 | 60 | % | Note ^b |

a. If the output of U4C in [Figure 1](#) is transmitted via a coaxial cable, terminate with a 50 Ω resistor to $V_{CC} - 2V$.

b. Run length-limited code with a maximum run length of 10 μs .

Link Performance

1 Mbaud to 125 Mbaud, BER $\leq 10^{-9}$, under recommended operating conditions with recommended transmit and receive application circuits.

| Parameter | Symbol | Min. ^a | Typ. ^b | Max. | Unit | Condition | Reference |
|--|------------------------|-------------------|-------------------|------|------|-----------|--------------------------|
| Optical Power Budget, 1m POF | OPB _{POF} | 11 | 16 | — | dB | — | Notes ^{c, d, e} |
| Optical Power Margin, 20m Standard POF | OPM _{POF,20} | 3 | 6 | — | dB | — | Notes ^{c, d, e} |
| Link Distance with Standard 1-mm POF | l | 20 | 27 | — | m | — | — |
| Optical Power Margin, 25m Low Loss POF | OPM _{POF,25} | 3 | 6 | — | dB | — | Notes ^{c, d, e} |
| Link Distance with Extra Low Loss 1-mm POF | l | 25 | 32 | — | m | — | — |
| Optical Power Budget, 1m HCS | OPB _{HCS} | 7 | 12 | — | dB | — | Notes ^{c, d, e} |
| Optical Power Margin, 100m HCS | OPM _{HCS,100} | 3 | 6 | — | dB | — | Notes ^{c, d, e} |
| Link Distance with HCS Cable | l | 100 | 125 | — | m | — | — |

a. Minimum link performance is projected based on the worst-case specifications of the HFBR-1527ETZ transmitter, HFBR-2526ETZ receiver, and POF cable and the typical performance of other components (for example, logic gates, transistors, resistors, capacitors, quantizer, HCS cable).

b. Typical performance is at 25°C, 125 Mbaud, and is measured with typical values of all circuit components.

c. The standard cable is HFBR-RXXYYYY plastic optical fiber, with a maximum attenuation of 0.24 dB/m at 650 nm and NA = 0.5. The Extra low loss cable is plastic optical fiber, with a maximum attenuation of 0.19 dB/m at 650 nm and NA = 0.5. The HCS cable is glass optical fiber, with a maximum attenuation of 10 dB/km at 650 nm and NA = 0.37.

d. The optical power budget (OPB) is the difference between the transmitter output power and the receiver sensitivity, measured after 1m of fiber. The minimum OPB is based on the limits of optical component performance over temperature, process, and recommended power supply variation.

e. The optical power margin (OPM) is the available OPB after including the effects of attenuation and modal dispersion for the minimum link distance: $OPM = OPB - (\text{attenuation power loss} + \text{modal dispersion power penalty})$. The minimum OPM is the margin available for long-term LED LOP degradation and additional fixed passive losses (such as inline connectors) in addition to the minimum specified distance.

Plastic Optical Fiber (1-mm POF) Transmitter Application Circuit

Performance of the HFBR-1527ETZ transmitter in the recommended application circuit (Figure 1) for POF; 1 Mbaud to 125 Mbaud, 25°C.

| Parameter | Symbol | Typical | Unit | Condition | Note |
|---|-----------|---------|------|----------------|------------------------------|
| Average Optical Power, 1-mm POF | P_{avg} | -9.7 | dBm | 50% Duty Cycle | Note ^a , Figure 3 |
| Average Modulated Power, 1-mm POF | P_{mod} | -11.3 | dBm | — | Note ^b , Figure 3 |
| Optical Rise Time (10% to 90%) | t_r | 2.1 | ns | 5 MHz | — |
| Optical Fall Time (90% to 10%) | t_f | 2.8 | ns | 5 MHz | — |
| High Level LED Current (On) | $I_{F,H}$ | 19 | mA | — | Note ^c |
| Low Level LED Current (Off) | $I_{F,L}$ | 3 | mA | — | Note ^c |
| Optical Overshoot, 1-mm POF | — | 45 | % | — | — |
| Transmitter Application Circuit Current Consumption, 1-mm POF | I_{CC} | 110 | mA | — | Figure 1 |

- a. Average optical power is measured with an average power meter at a 50% duty cycle, after 1m of fiber.
- b. To allow the LED to switch at high speeds, the recommended drive circuit modulates LED light output between two nonzero power levels. The modulated (useful) power is the difference between the high and low level of light output power (transmitted) or input power (received), which can be measured with an average power meter as a function of duty cycle (see Figure 3). Average modulated power is defined as one half the slope of the average power versus the duty cycle:

$$\text{Average Modulated Power} = \frac{[P_{avg} @ 80\% \text{ duty cycle} - P_{avg} @ 20\% \text{ duty cycle}]}{(2) [0.80 - 0.20]}$$

- c. High-level and low-level LED currents refer to the current through the HFBR-1527ETZ LED. The low-level LED “off” current, sometimes referred to as “hold-on” current, is prebias supplied to the LED during the off state to facilitate fast switching speeds.

Hard Clad Silica Fiber (200- μm HCS) Transmitter Application Circuit

Performance of the HFBR-1527ETZ transmitter in the recommended application circuit (Figure 1) for HCS; 1 Mbaud to 125 Mbaud, 25°C.

| Parameter | Symbol | Typical | Unit | Condition | Note |
|---|------------------|---------|------|----------------|------------------------------|
| Average Optical Power, 200- μm HCS | P_{avg} | -14.6 | dBm | 50% Duty Cycle | Note ^a , Figure 3 |
| Average Modulated Power, 200- μm HCS | P_{mod} | -6.2 | dBm | — | Note ^b , Figure 3 |
| Optical Rise Time (10% to 90%) | t_r | 3.1 | ns | 5 MHz | — |
| Optical Fall Time (90% to 10%) | t_f | 3.4 | ns | 5 MHz | — |
| High Level LED Current (On) | $I_{F,H}$ | 60 | mA | — | Note ^c |
| Low Level LED Current (Off) | $I_{F,L}$ | 6 | mA | — | Note ^c |
| Optical Overshoot, 200- μm HCS | — | 30 | % | — | — |
| Transmitter Application Circuit Current Consumption, 200- μm HCS | I_{CC} | 130 | mA | — | Figure 1 |

- a. Average optical power is measured with an average power meter at a 50% duty cycle, after 1m of fiber.
- b. To allow the LED to switch at high speeds, the recommended drive circuit modulates LED light output between two nonzero power levels. The modulated (useful) power is the difference between the high and low level of light output power (transmitted) or input power (received), which can be measured with an average power meter as a function of the duty cycle (see Figure 3). Average modulated power is defined as one half the slope of the average power versus the duty cycle:

$$\text{Average Modulated Power} = \frac{[P_{\text{avg}} @ 80\% \text{ duty cycle} - P_{\text{avg}} @ 20\% \text{ duty cycle}]}{(2) [0.80 - 0.20]}$$

- c. High-level and low-level LED currents refer to the current through the HFBR-1527ETZ LED. The low-level LED “off” current, sometimes referred to as “hold-on” current, is prebias supplied to the LED during the off state to facilitate fast switching speeds.

Plastic and Hard Clad Silica Optical Fiber Receiver Application Circuit

Performance^a of the HFBR-2526ETZ receiver in the recommended application circuit ([Figure 1](#)); 1 Mbaud to 125 Mbaud, 25°C, unless otherwise stated.

| Parameter | Symbol | Typical | Unit | Condition | Note |
|---|-----------|----------------|------|------------------|--------------------------|
| Data Output Voltage – Low | V_{OL} | $V_{CC} - 1.7$ | V | $R_L = 50\Omega$ | Note ^b |
| Data Output Voltage – High | V_{OH} | $V_{CC} - 0.9$ | V | $R_L = 50\Omega$ | Note ^b |
| Receiver Sensitivity to Average Modulated Optical Power, 1-mm POF | P_{min} | -27.5 | dBm | 50% eye opening | Note ^c |
| Receiver Sensitivity to Average Modulated Optical Power, 200- μ m HCS | P_{min} | -28.5 | dBm | 50% eye opening | Note ^c |
| Receiver Overdrive Level of Average Modulated Optical Power, 1-mm POF | P_{max} | -7.5 | dBm | 50% eye opening | Note ^c |
| Receiver Overdrive Level of Average Modulated Optical Power, 200- μ m HCS | P_{max} | -10.5 | dBm | 50% eye opening | Note ^c |
| Receiver Application Circuit Current Consumption | I_{CC} | 85 | mA | $R_L = \infty$ | Figure 1 |

- Performance in response to a signal from the HFBR-1527ETZ transmitter driven with the recommended circuit at 1 Mbaud to 125 Mbaud over 1m of HFBR-RZ/EXXYYYZ plastic optical fiber or 1m of hard clad silica optical fiber.
- Terminated through a 50 Ω resistor to $V_{CC} - 2V$.
- If there is no input optical power to the receiver, electrical noise can result in false triggering of the receiver. In typical applications, data encoding and error detection prevent random triggering from being interpreted as valid data.

Figure 1: Transmitter and Receiver Application Circuit with +5V ECL Inputs and Outputs

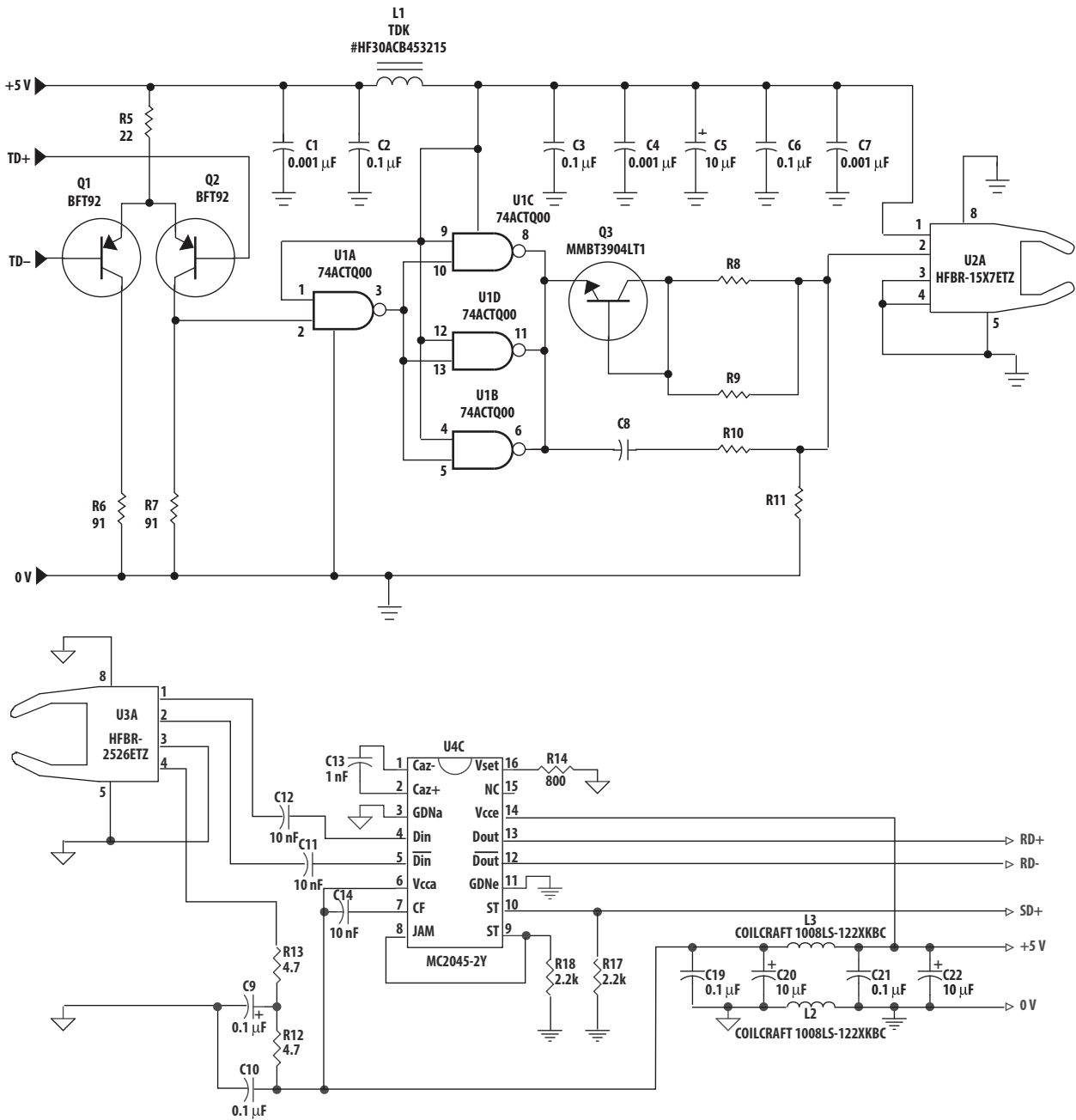

Figure 2: Recommended Power Supply Filter and +5V ECL Signal Terminations for the Transmitter and Receiver Application Circuit of Figure 1

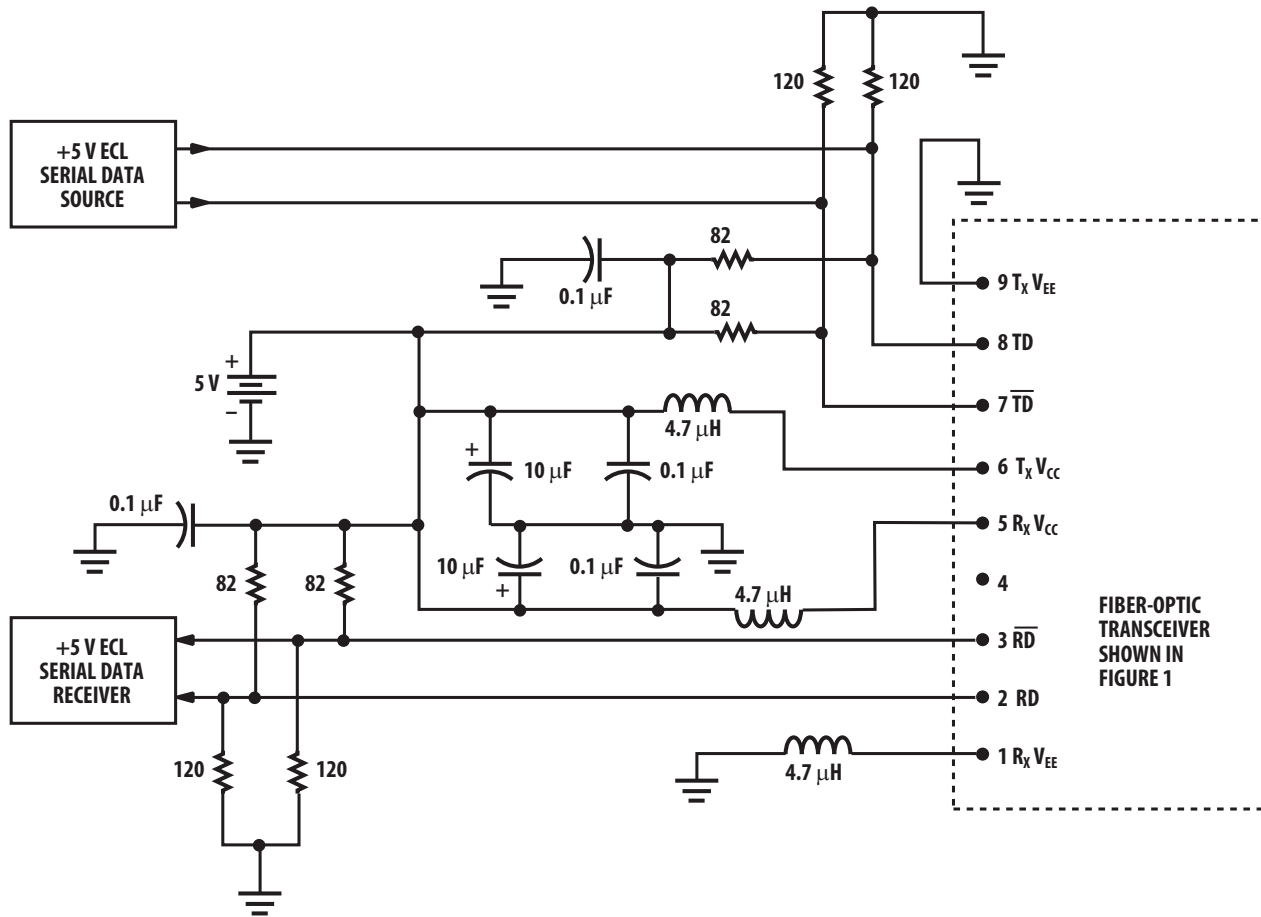

Figure 3: Average Modulated Power

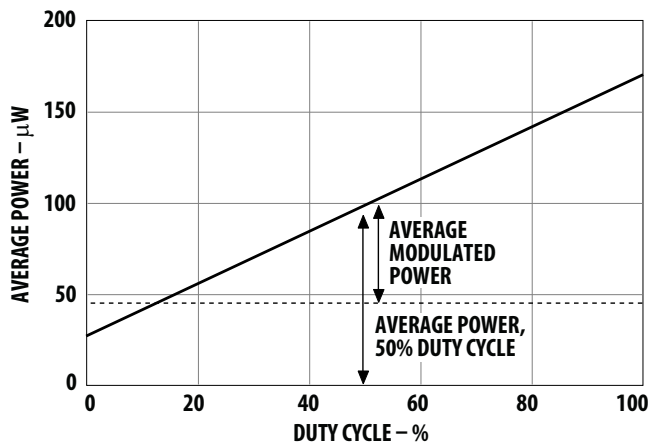
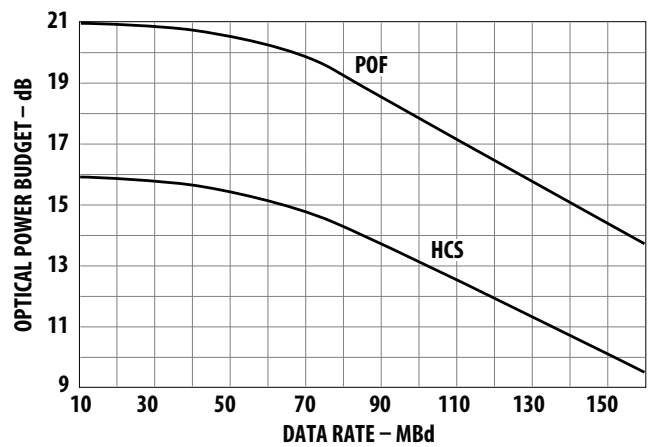

Figure 4: Typical Optical Power Budget vs. Data Rate



125-Megabaud Versatile Link Transmitter

HFBR-1527ETZ Series

Description

The HFBR-1527ETZ transmitters incorporate a 650-nm LED in a horizontal (HFBR-1527ETZ) gray housing. The HFBR-1527ETZ transmitters are suitable for use with current peaking to decrease response time, and they can be used with HFBR-2526ETZ receivers in data links operating at signal rates from 1 Mbaud to 125 Mbaud over 1-mm diameter plastic optical fiber or 200- μ m diameter hard clad silica glass optical fiber.

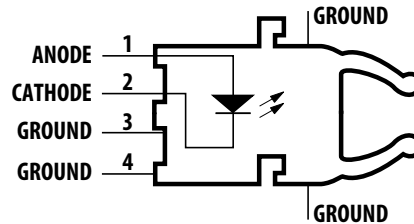

NOTE: Pins 5 and 8 are primarily for mounting and retaining purposes, but are electrically connected; pins 3 and 4 are electrically unconnected. It is recommended that pins 3, 4, 5, and 8 all be connected to ground to reduce coupling of electrical noise.

Absolute Maximum Ratings

| Parameter | Symbol | Min. | Max. | Unit | Reference |
|--|------------|------|------|--------------------|--------------------------------|
| Storage Temperature | T_S | -40 | 85 | $^{\circ}\text{C}$ | — |
| Operating Temperature | T_O | -40 | 85 | $^{\circ}\text{C}$ | — |
| Lead Soldering Temperature Cycle Time | — | — | 260 | $^{\circ}\text{C}$ | Notes a, b |
| | — | — | 10 | s | |
| Transmitter High Level Forward Input Current | $I_{F,H}$ | — | 120 | mA | 50% Duty Cycle ≥ 1 MHz |
| Transmitter Average Forward Input Current | $I_{F,AV}$ | — | 60 | mA | — |
| Reverse Input Voltage | V_R | — | 3 | V | — |

a. 1.6 mm below the seating plane. To guard against solder process fluctuations, the recommended nominal soldering time is 5 seconds.

b. The moisture sensitivity level is MSL-3.

CAUTION! The small junction sizes inherent to the design of this component increase the component's susceptibility to damage from electrostatic discharge (ESD). It is advised that normal static precautions be taken in handling and assembly of this component to prevent damage and/or degradation that may be induced by ESD.

WARNING! When viewed under some conditions, the optical port may expose the eye beyond the maximum permissible exposure recommended in ANSI z136.2, 1993. Under most viewing conditions, there is no eye hazard.

Electrical/Optical Characteristics

–40 to 85°C, unless otherwise stated.

| Parameter | Symbol | Min. | Typ. ^a | Max. | Unit | Condition | Note |
|---|-----------------------------------|-------|-------------------|-------|-------|--|-------------------------------|
| Transmitter Output Peak Optical Power, 1-mm POF | P_T | –9.5 | –7.0 | –4.8 | dBm | $I_{F,dc} = 20 \text{ mA}$, 25°C | Note ^b |
| | | –10.4 | — | –3.5 | | –40°C to 85°C | NA = 0.5 |
| Transmitter Output Peak Optical Power, 1-mm POF | P_T | –6.0 | –3.0 | –0.5 | dBm | $I_{F,dc} = 60 \text{ mA}$, 25°C | Note ^b |
| | | –6.9 | — | 0.8 | | –40°C to 85°C | NA = 0.5 |
| Transmitter Output Peak Optical Power, 200- μm HCS | P_T | –14.6 | –13.0 | –10.5 | dBm | $I_{F,dc} = 60 \text{ mA}$, 25°C | Note ^b |
| | | –16.0 | — | –9.2 | | –40°C to 85°C | NA = 0.x |
| Output Optical Power Temperature Coefficient | $\frac{\Delta P_T}{\Delta T}$ | — | –0.02 | — | dB/°C | — | — |
| Peak Emission Wavelength | λ_{PK} | 635 | 650 | 662 | nm | — | — |
| Peak Wavelength Temperature Coefficient | $\frac{\Delta \lambda}{\Delta T}$ | — | 0.12 | — | nm/°C | — | — |
| Spectral Width | FWHM | — | 21 | — | nm | Full Width, Half Maximum | — |
| Forward Voltage | V_F | 1.8 | 2.1 | 2.65 | V | $I_F = 60 \text{ mA}$ | — |
| Forward Voltage Temperature Coefficient | $\frac{\Delta V_F}{\Delta T}$ | — | –1.8 | — | mV/°C | — | — |
| Thermal Resistance, Junction to Case | θ_{jc} | — | 140 | — | °C/W | — | Note ^c |
| Reverse Input Breakdown Voltage | V_{BR} | 3.0 | 13 | — | V | $I_{F,dc} = -10 \mu\text{A}$ | — |
| Diode Capacitance | C_O | — | 60 | — | pF | $V_F = 0\text{V}$, $f = 1 \text{ MHz}$ | — |
| Unpeaked Optical Rise Time, 10% – 90% | t_r | — | 10 | — | ns | $I_F = 60 \text{ mA}$ $f = 100 \text{ kHz}$ | Figure 1 Note ^d |
| Unpeaked Optical Fall Time, 90% –10% | t_f | — | 11 | — | ns | $I_F = 60 \text{ mA}$ $f = 100 \text{ kHz}$ | Figure 1 Note ^d |

a. Typical data is at 25°C.

b. The optical power is measured at the end of either 0.5m of 1-mm diameter POF (NA = 0.5) or 5m of 200- μm diameter HCS (NA = 0.37) with a large area detector.

c. The typical value is measured from the junction to the PC board solder joint for the horizontal mount package, HFBR-1527ETZ.

d. Optical rise and fall times can be reduced with the appropriate driver circuit.

Refer to the [Plastic Optical Fiber Cable and Accessories for Versatile Link Data Sheet](#) for cable and connector options for 1-mm plastic optical fibers, and refer to [Application Note 1035](#) for further information about the Broadcom Versatile Link Family.

The LED current peaking necessary for high-frequency circuit design contributes to electromagnetic interference (EMI). Care must be taken in circuit board layout to minimize emissions for compliance with governmental EMI emissions regulations.

Figure 5: Test Circuit for Measuring Unpeaked Rise and Fall Times

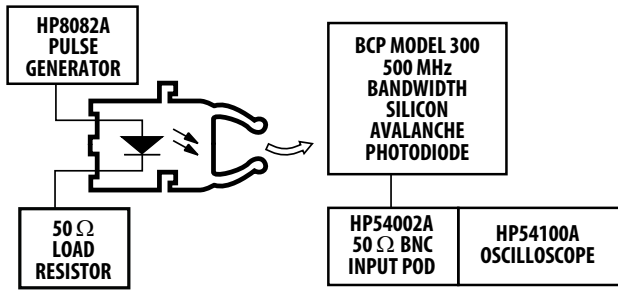

Figure 6: Typical Spectra at 25°C

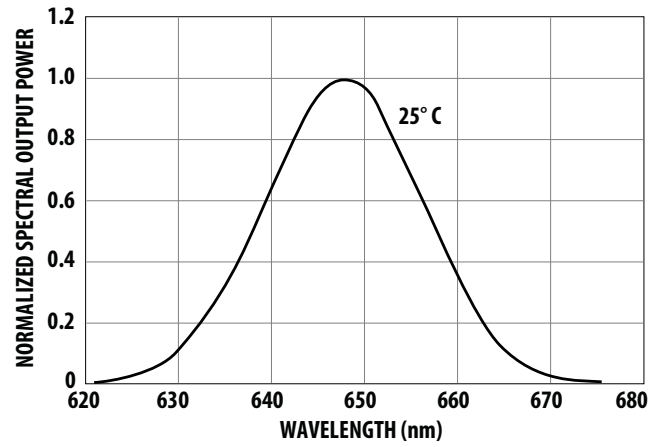

Figure 7: Typical Forward Voltage vs. Drive Current

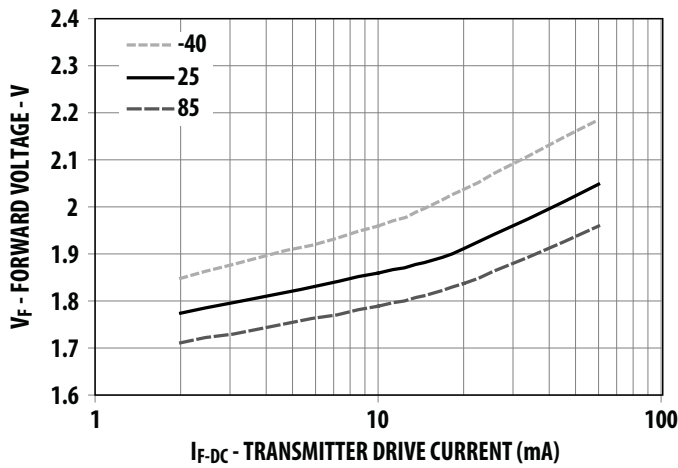
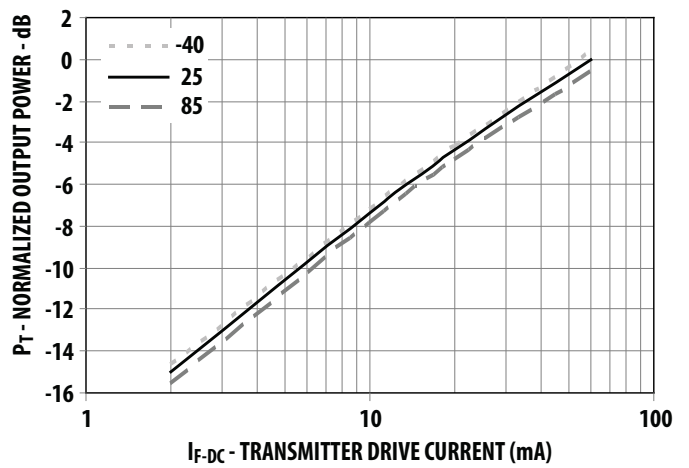

Figure 8: Typical Normalized Output Optical Power vs. Drive Current



125-Megabaud Versatile Link Receiver

HFBR-2526ETZ Series

Description

The HFBR-2526ETZ receivers contain a PIN photodiode and transimpedance preamplifier circuit in a horizontal (HFBR-2526ETZ) blue housing, and they are designed to interface to 1-mm diameter plastic optical fiber or 200- μm hard clad silica glass optical fiber. The receivers convert a received optical signal to analog output voltage. Follow-on circuitry can optimize link performance for a variety of distance and data rate requirements. Electrical bandwidth greater than 65 MHz allows design of high-speed data links with plastic or hard clad silica optical fiber.

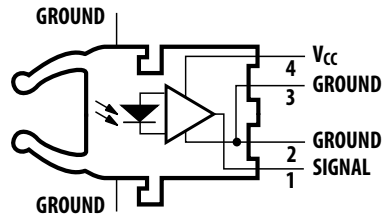

NOTE:

1. The signal output is an emitter follower, which does not reject noise in the power supply. The power supply must be filtered as in [Figure 1](#).
2. Pin 1 should be AC coupled to a load $\geq 510\Omega$ with a load capacitance less than 5 pF.
3. Pins 5 and 8 are primarily for mounting and retaining purposes, but are electrically connected. It is recommended that these pins be connected to ground to reduce coupling of electrical noise.

Absolute Maximum Ratings

| Parameter | Symbol | Min. | Max. | Unit | Reference |
|---------------------------------------|----------|------|----------|--------------------|------------|
| Storage Temperature | T_S | -40 | 85 | $^{\circ}\text{C}$ | — |
| Operating Temperature | T_A | -40 | 85 | $^{\circ}\text{C}$ | — |
| Lead Soldering Temperature Cycle Time | — | — | 260 | $^{\circ}\text{C}$ | Notes a, b |
| | — | — | 10 | s | |
| Signal Pin Voltage | V_O | -0.5 | V_{CC} | V | — |
| Supply Voltage | V_{CC} | -0.5 | 6.0 | V | — |
| Output Current | I_O | — | 25 | mA | — |

a. 1.6 mm below the seating plane. To guard against solder process fluctuations, the recommended nominal soldering time is 5 seconds.

b. The moisture sensitivity level is MSL-4.

CAUTION! The small junction sizes inherent to the design of this component increase the component's susceptibility to damage from electrostatic discharge (ESD). It is advised that normal static precautions be taken in handling and assembly of this component to prevent damage and/or degradation that may be induced by ESD.

Electrical/Optical Characteristics

−40°C to 85°C; 5.25V ≥ V_{CC} ≥ 4.75V; power supply must be filtered (see Figure 1, Note ^a).

| Parameter | Symbol | Min. | Typ. | Max. | Unit | Test Condition | Note |
|--|--------------------|------|------|------|-------------------|-------------------------------|------|
| AC Responsivity, 1-mm POF | R _{P,APF} | 1.7 | 3.9 | 6.5 | mV/μW | 650 nm | b |
| AC Responsivity, 200-μm HCS | R _{P,HCS} | 4.5 | 7.9 | 11.5 | mV/μW | — | — |
| RMS Output Noise | V _{NO} | — | 0.46 | 0.69 | mV _{RMS} | — | c |
| Equivalent Optical Noise Input Power, RMS – 1-mm POF | P _{N,RMS} | — | −39 | −36 | dBm | — | c |
| Equivalent Optical Noise Input Power, RMS – 200-μm HCS | P _{N,RMS} | — | −42 | −40 | dBm | — | c |
| Peak Input Optical Power – 1-mm POF | P _R | — | — | −5.8 | dBm | 5 ns PWD | d |
| | | — | — | −6.4 | dBm | 2 ns PWD | |
| Peak Input Optical Power – 200-μm HCS | P _R | — | — | −8.8 | dBm | 5 ns PWD | d |
| | | — | — | −9.4 | dBm | 2 ns PWD | |
| Output Impedance | Z _O | — | 30 | — | Ω | 50 MHz | b |
| DC Output Voltage | V _O | 0.8 | 1.8 | 2.6 | V | P _R = 0 μW | — |
| Supply Current | I _{CC} | — | 9 | 15 | mA | — | — |
| Electrical Bandwidth | BW _E | 65 | 125 | — | MHz | −3 dB electrical | — |
| Bandwidth * Rise Time | — | — | 0.41 | — | Hz * s | — | — |
| Electrical Rise Time, 10–90% | t _r | — | 3.3 | 6.3 | ns | P _R = −10 dBm peak | — |
| Electrical Fall Time, 90–10% | t _f | — | 3.3 | 6.3 | ns | P _R = −10 dBm peak | — |
| Pulse Width Distortion | PWD | — | 0.4 | 1.0 | ns | P _R = −10 dBm peak | e |
| Overshoot | — | — | 4 | — | % | P _R = −10 dBm peak | f |

- a. The signal output is an emitter follower, which does not reject noise in the power supply. The power supply must be filtered as in Figure 1.
- b. Pin 1 should be AC coupled to a load ≥ 510Ω with a load capacitance less than 5 pF.
- c. Measured with a 3-pole Bessel filter with a 75-MHz, −3-dB bandwidth.
- d. The maximum peak input optical power is the level at which the pulse width distortion is guaranteed to be less than the PWD listed under the test condition. P_{R,Max} is given for PWD = 5 ns for designing links at ≤ 50-Mbaud operation and is also given for PWD = 2 ns for designing links up to 125 Mbaud (for both POF and HCS input conditions).
- e. 10-ns pulse width, 50% duty cycle, at the 50% amplitude point of the waveform.
- f. The percent overshoot is defined as follows:

$$\frac{(V_{PK} - V_{100\%})}{V_{100\%}} \times 100\%$$

If there is no input optical power to the receiver (no transmitted signal), electrical noise can result in false triggering of the receiver. In typical applications, data encoding and error detection prevent random triggering from being interpreted as valid data.

Figure 9: Recommended Power Supply Filter Circuit

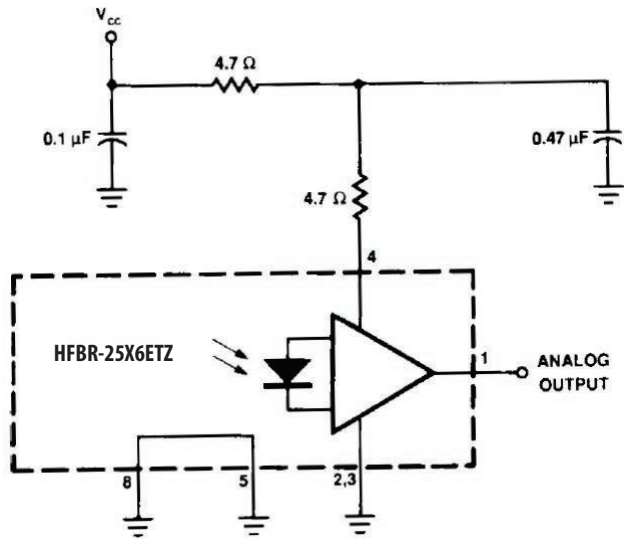

Figure 10: Simplified Receiver Schematic

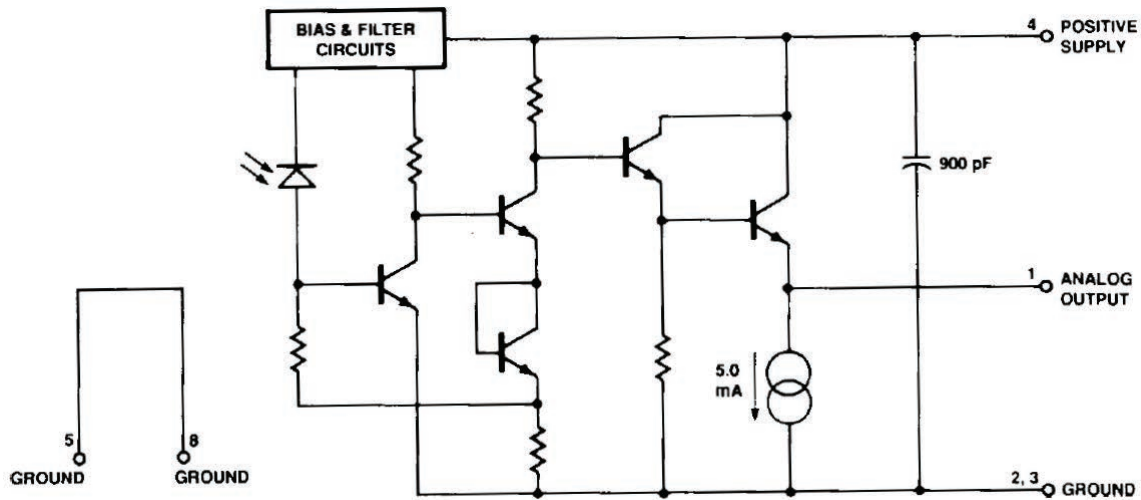

Figure 11: Typical Pulse Width Distortion vs. Peak Input Power

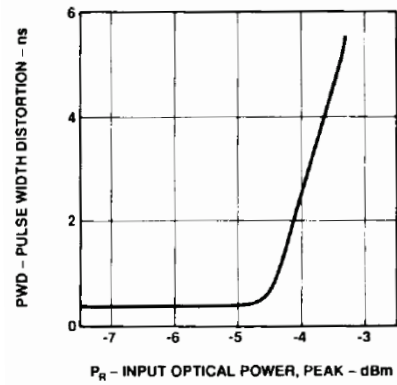

Figure 12: Typical Output Spectral Noise Density vs. Frequency

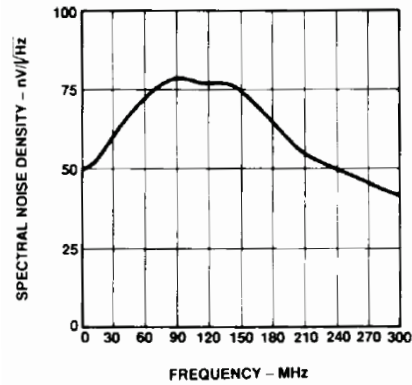
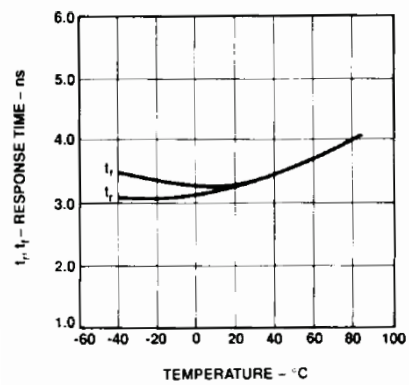
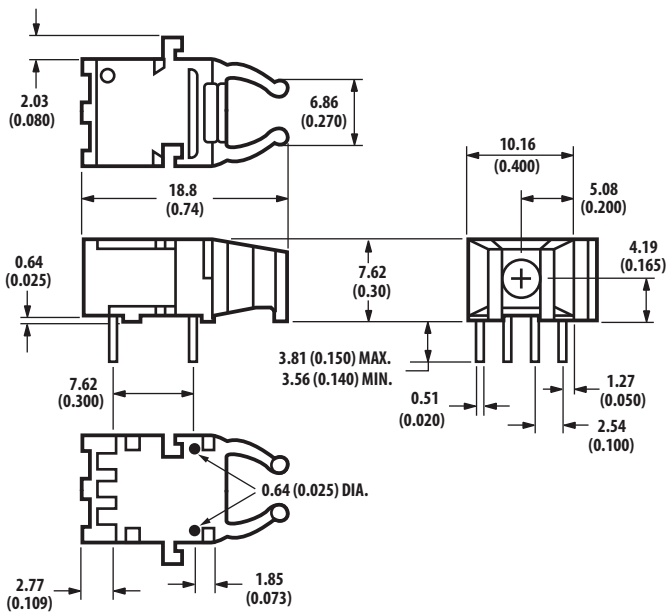

Figure 13: Typical Rise and Fall Time vs. Temperature



Versatile Link Mechanical Dimensions

Horizontal Modules HFBR-1527ETZ HFBR-2526ETZ



Versatile Link Printed Circuit Board Layout Dimensions

Top Views Horizontal Module

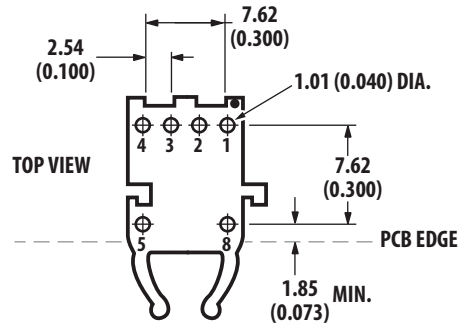

NOTE: Dimensions are in millimeters (inches).

Electrical Pin Functions

| Pin No. | Transmitters HFBR-1527ETZ | Receivers HFBR-2526ETZ |
|---------|------------------------------|---------------------------|
| 1 | ANODE | SIGNAL |
| 2 | CATHODE | GROUND |
| 3 | GROUND ^a | GROUND |
| 4 | GROUND ^a | V _{CC} (+5V) |
| 5 | GROUND ^b | GROUND ^b |
| 8 | GROUND ^b | GROUND ^b |

a. No internal connection.

b. Pins 5 and 8 connected internally to each other only.

Copyright © 2005–2023 Broadcom. All Rights Reserved. The term “Broadcom” refers to Broadcom Inc. and/or its subsidiaries. For more information, go to www.broadcom.com. All trademarks, trade names, service marks, and logos referenced herein belong to their respective companies.

Broadcom reserves the right to make changes without further notice to any products or data herein to improve reliability, function, or design. Information furnished by Broadcom is believed to be accurate and reliable. However, Broadcom does not assume any liability arising out of the application or use of this information, nor the application or use of any product or circuit described herein, neither does it convey any license under its patent rights nor the rights of others.