

# HSMW-B191, HSMW-B265, HSMW-B197, HSMW-B120

## Bluish White ChipLEDs

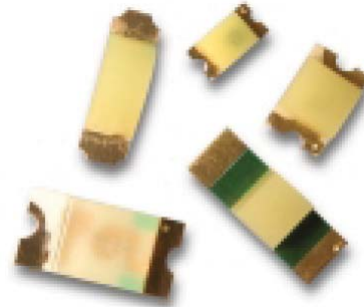

## Data Sheet



### Description

These pastel ChipLEDs come in unique shades of white and provide product differentiation for back-lighting applications. They are designed in industry standard packages for ease of handling and use.

These chipLEDs come in either top emitting packages (HSMW-B191, 265 & 197) or in a side emitting package (HSMW-B120).

The packages are compatible with IR reflow soldering processes and comes in 8 mm tape on 7" diameter reels. They are compatible with automatic placement equipment.

In order to facilitate pick and place operation, these chipLEDs are shipped in tape and reel with 4000 units per reel for HSMW-B191, 197, and 120 packages, and 3000 units per reel for HSMW-B265 packages.

### Features

- Unique pastel white colors
- Small size
- Industry standard footprint
- Compatible with IR soldering
- Compatible with automatic placement equipment
- Operating temperature range -40°C to +85°C
- Come in 8 mm tape on 7" diameter reels

### Applications

- LCD backlighting
- Keypad backlighting
- Pushbutton backlighting
- Symbol backlighting

**CAUTION:** HSMW-Bxxx LEDs are Class 1A ESD sensitive per JESD22-A114C.01. Please observe appropriate precautions during handling and processing. Refer to Avago Technologies Application Note AN-1142 for additional details.

# Package Dimensions

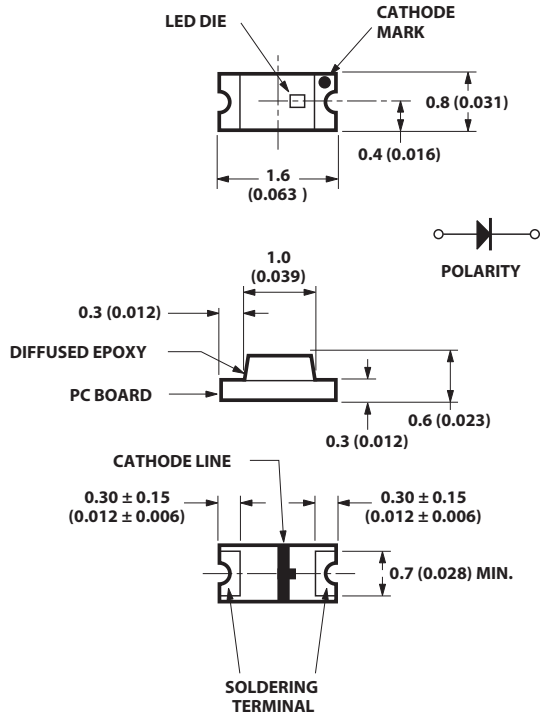

**HSMW-B191**

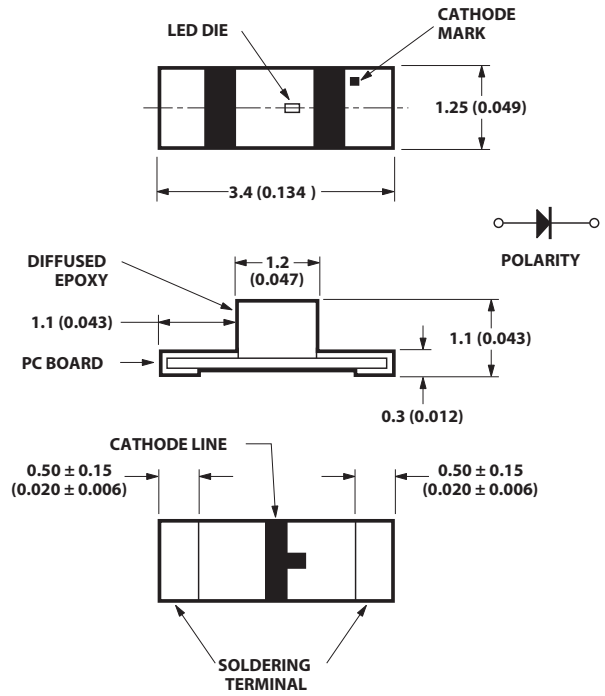

**HSMW-B265**

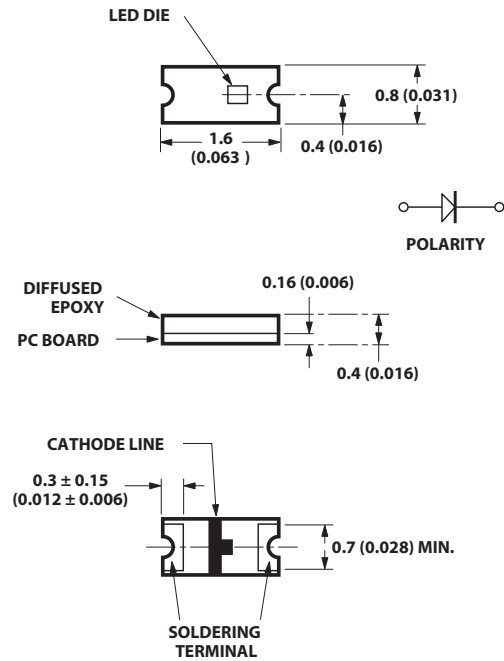

**HSMW-B197**

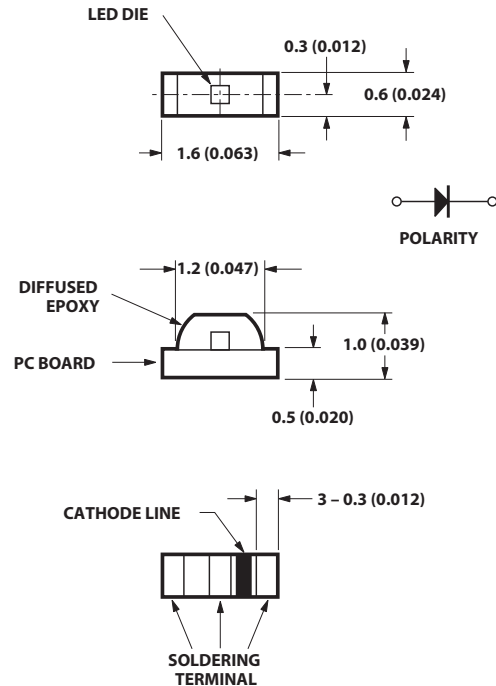

**HSMW-B120**

- NOTES:
1. DIMENSIONS ARE IN MILLIMETERS (INCHES).
  2. TOLERANCE ± 0.1 mm UNLESS OTHERWISE NOTED.

## Device Selection Guide

Package Dimension (mm)	Bluish White	Package Description
1.6 (L) x 0.8 (W) x 0.6 (H)	HSMW-B191	Untinted, Diffused
3.4 (L) x 1.25 (W) x 1.1 (H) <sup>[2]</sup>	HSMW-B265	Untinted, Diffused
1.6 (L) x 0.8 (W) x 0.4 (H)	HSMW-B197	Untinted, Diffused
1.6 (L) x 0.6 (W) x 1.0 (H) <sup>[1]</sup>	HSMW-B120	Untinted, Diffused

### Notes:

1. Right angle package.
2. Reverse mount package.

## Absolute Maximum Ratings at $T_A = 25^\circ\text{C}$

Parameter	HSMW-Bxxx	Units
DC Forward Current <sup>[1]</sup>	20	mA
Power Dissipation	78	mW
Reverse Voltage ( $I_R = 100\ \mu\text{A}$ )	5	V
LED Junction Temperature	95	$^\circ\text{C}$
Operating Temperature Range	-40 to +85	$^\circ\text{C}$
Storage Temperature Range	-40 to +85	$^\circ\text{C}$
Soldering Temperature	See reflow soldering profile (Figures 9 & 10)	

### Note:

1. Derate linearly as shown in Figure 4.

## Electrical Characteristics at $T_A = 25^\circ\text{C}$

Part Number	Forward Voltage $V_F$ (Volts) @ $I_F = 20\ \text{mA}$ <sup>[1]</sup>		Reverse Breakdown $V_R$ (Volts) @ $I_R = 100\ \mu\text{A}$	Capacitance C (pF), $V_F = 0$ , $f = 1\ \text{MHz}$	Thermal Resistance $R\theta_{J-PIN}$ ( $^\circ\text{C}/\text{W}$ )
	Typ.	Max.	Min.	Typ.	Typ.
HSMW-Bxxx	3.6	3.9	5	55	450

### Note:

1.  $V_F$  tolerance:  $\pm 0.1\ \text{V}$

## Optical Characteristics at $T_A = 25^\circ\text{C}$

Part Number	Luminous Intensity $I_v$ (mcd) @ $20\ \text{mA}$ <sup>[1,4]</sup>		Chromaticity Coordinates <sup>[2]</sup>		Viewing Angle $2\theta_{1/2}$ Degrees <sup>[3]</sup>	Luminous Efficacy $\eta_v$ (lm/w)
	Min.	Typ.	x	y	Typ.	Typ.
HSMW-B191	28.5	110.0	0.20	0.19	140	170
HSMW-B265	28.5	110.0	0.20	0.19	150	170
HSMW-B120	28.5	110.0	0.20	0.19	155	170
HSMW-B197	28.5	110.0	0.20	0.19	130	170

### Notes:

1. The luminous intensity,  $I_v$ , is measured at the peak of the spatial radiation pattern which may not be aligned with the mechanical axis of the lamp package.
2. The dominant wavelength,  $\lambda_d$ , is derived from the CIE Chromaticity Diagram and represents the perceived color of the device.
3.  $\theta_{1/2}$  is the off-axis angle where the luminous intensity is 1/2 the peak intensity.
4. Luminous intensity ( $I_v$ ) tolerance:  $\pm 15\%$ .

## Light Intensity (Iv) Bin Limits<sup>[1]</sup>

Bin ID	Intensity (mcd)	
	Min.	Max.
A	0.11	0.18
B	0.18	0.29
C	0.29	0.45
D	0.45	0.72
E	0.72	1.10
F	1.10	1.80
G	1.80	2.80
H	2.80	4.50
J	4.50	7.20
K	7.20	11.20
L	11.20	18.00
M	18.00	28.50
N	28.50	45.00
P	45.00	71.50
Q	71.50	112.50
R	112.50	180.00
S	180.00	285.00
T	285.00	450.00
U	450.00	715.00
V	715.00	1125.00
W	1125.00	1800.00
X	1800.00	2850.00
Y	2850.00	4500.00

Tolerance:  $\pm 15\%$

**Note:**

1. Bin categories are established for classification of products. Products may not be available in all categories. Please contact your Avago representative for information on currently available bins.

SMT BLUISH WHITE COLOR BIN STRUCTURES

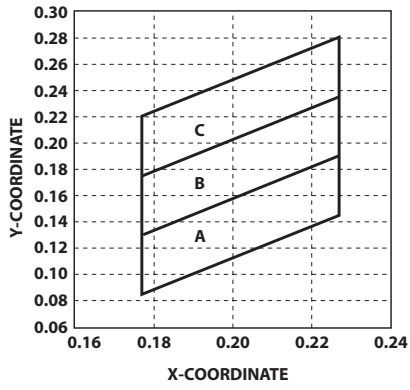

Figure 1. Color bin limits (CIE 1931 Chromaticity Diagram) [Tolerance:  $\pm 0.02$ ].

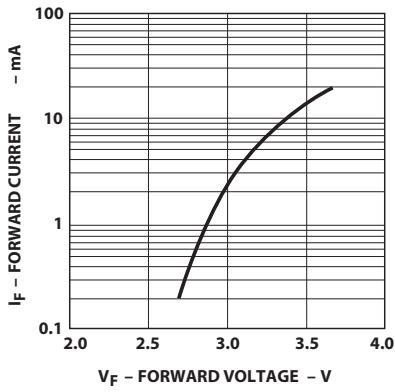

Figure 2. Forward current vs. forward voltage.

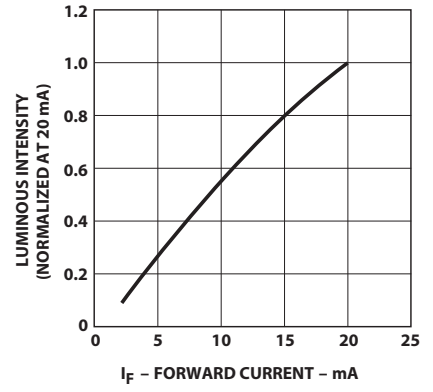

Figure 3. Luminous intensity vs. forward current.

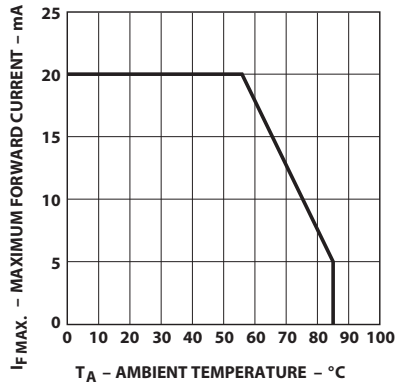

Figure 4. Maximum forward current vs. ambient temperature.

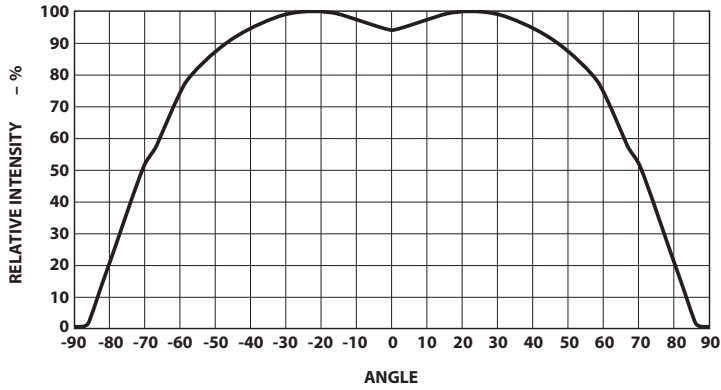

Figure 5. Relative intensity vs. angle for HSMW-B191.

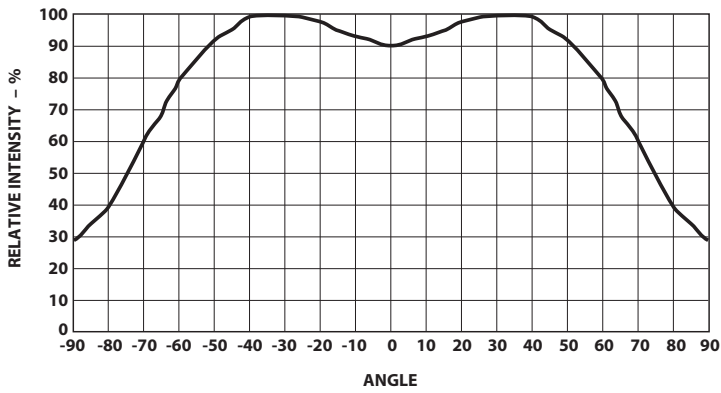

Figure 6. Relative intensity vs. angle for HSMW-B265.

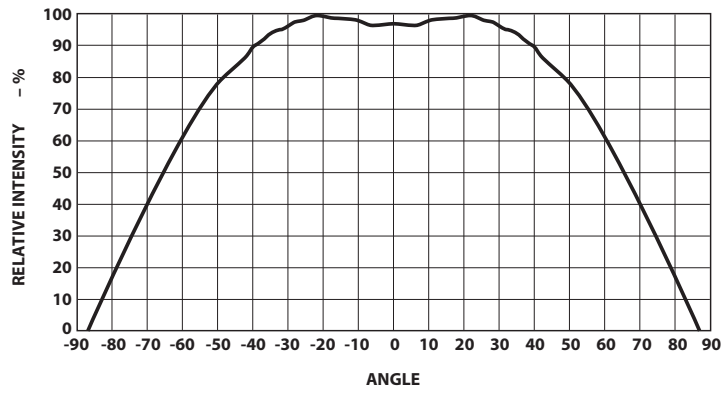

Figure 7. Relative intensity vs. angle for HSMW-B197.

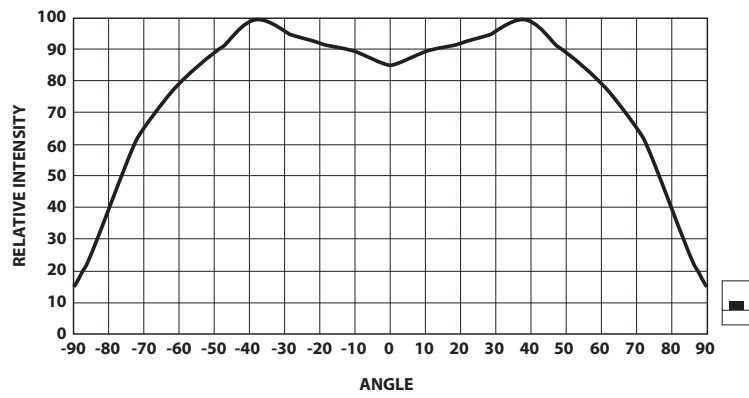
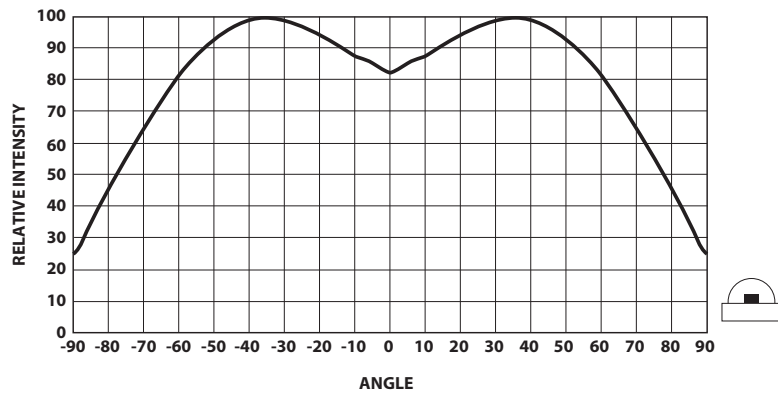

Figure 8. Relative intensity vs. angle for HSMW-B120.

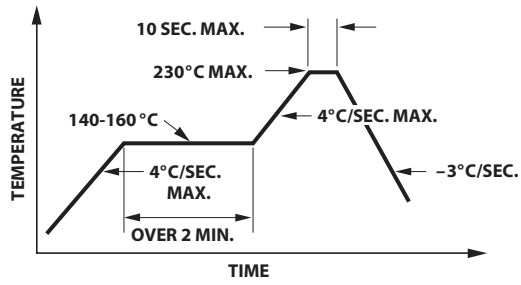

Figure 9. Recommended reflow soldering profile.

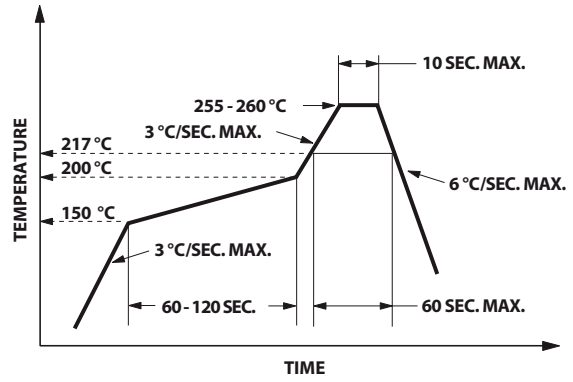

Figure 10. Recommended Pb-free reflow soldering profile.

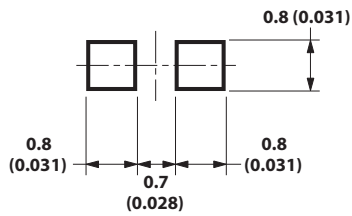

Figure 11. Recommended soldering pattern for HSMW-B191 and HSMW-B197.

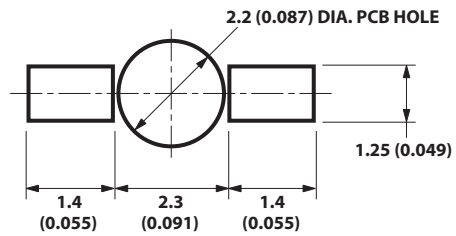

Figure 12. Recommended soldering pad pattern for HSMW-B265.

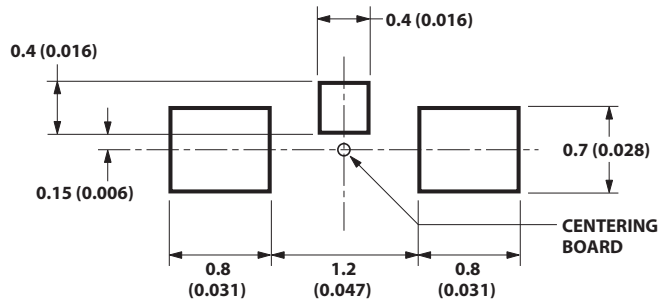

Figure 13. Recommended soldering pad pattern for HSMW-B120.

**NOTE:**

1. DIMENSIONS ARE IN MILLIMETERS (INCHES).

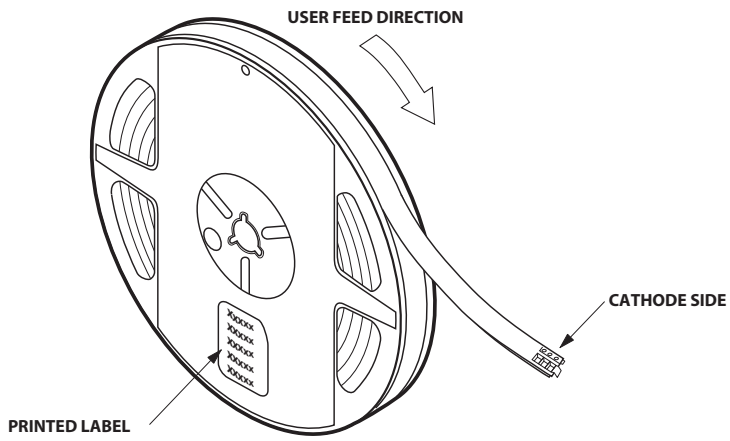

Figure 14. Reeling orientation.

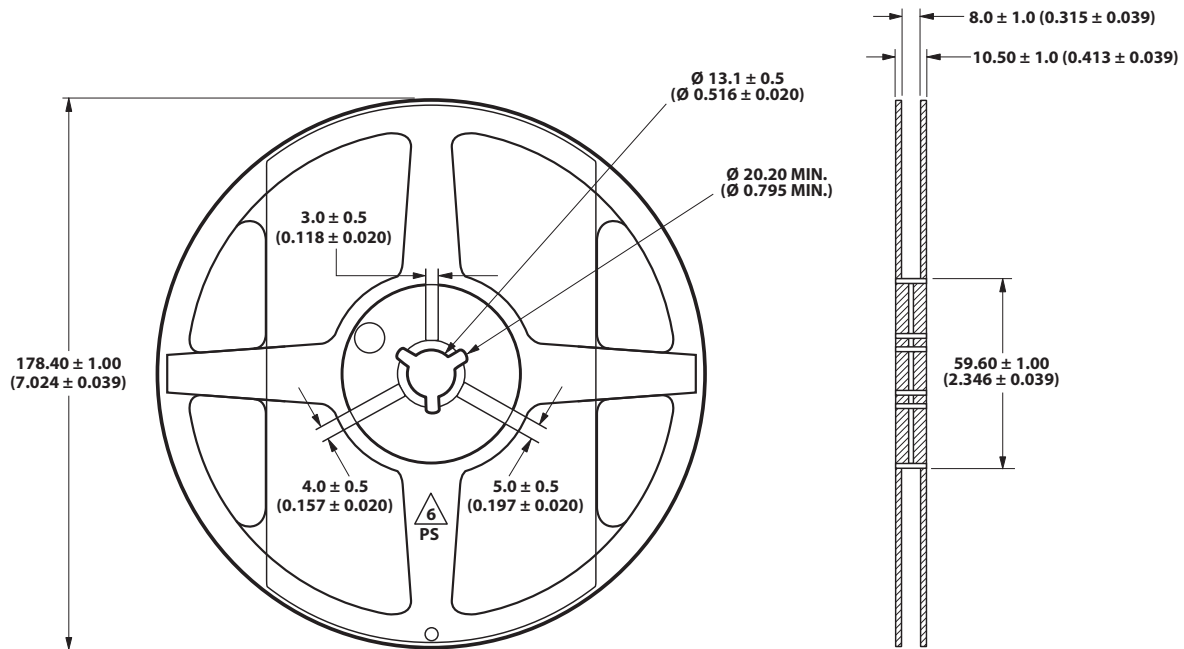

Figure 15. Reel dimensions.

NOTE:  
1. DIMENSIONS ARE IN MILLIMETERS (INCHES).



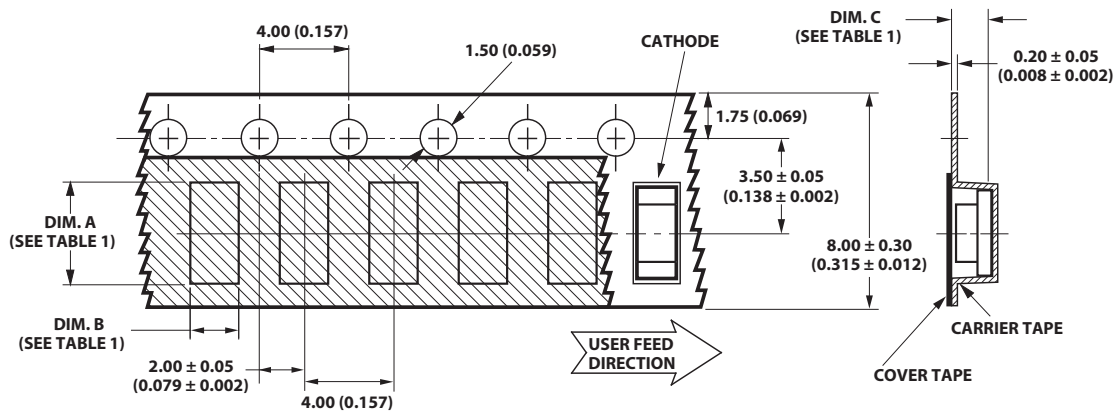

TABLE 1  
DIMENSIONS IN MILLIMETERS (INCHES)

PART NUMBER	DIM. A ± 0.10 (± 0.004)	DIM. B ± 0.10 (± 0.004)	DIM. C ± 0.10 (± 0.004)
HSMW-B191 SERIES	1.85 (0.073)	0.88 (0.035)	0.85 (0.033)
HSMW-B197 SERIES	1.75 (0.069)	0.95 (0.037)	0.60 (0.024)
HSMW-B120 SERIES	1.90 (0.075)	1.15 (0.045)	0.80 (0.031)

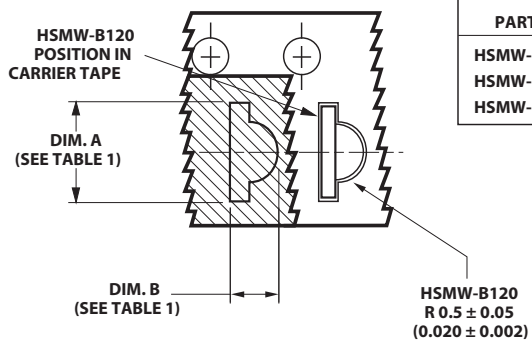

TABLE 1  
DIMENSIONS IN MILLIMETERS (INCHES)

PART NUMBER	DIM. A ± 0.10 (0.004)	DIM. B ± 0.10 (0.004)	DIM. C ± 0.10 (0.004)
HSMx-C265 SERIES	3.70 (0.146)	1.45 (0.057)	1.30 (0.051)

Figure 16. Tape dimensions.

NOTE:

1. DIMENSIONS ARE IN MILLIMETERS (INCHES).

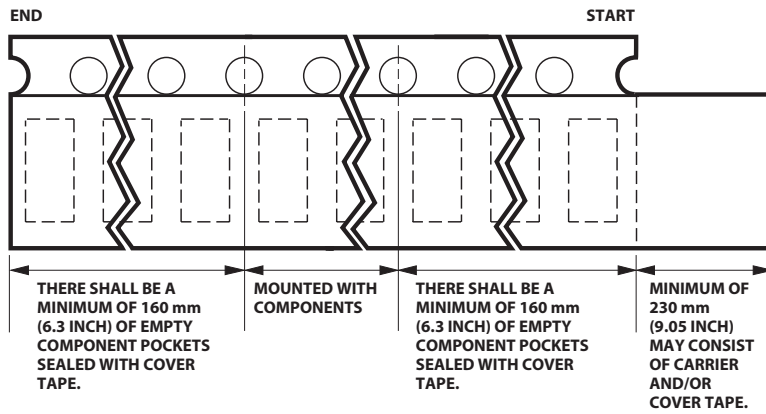

Figure 17. Tape leader and trailer dimensions.

### Convective IR Reflow Soldering

For more information on IR reflow soldering, refer to Application Note 1060, *Surface Mounting SMT LED Indicator Components*.

### Storage Condition: 5 to 30°C @ 60% RH max.

Baking is required under the condition:

1. Humidity Indicator Card is >10% when read at 23±5°C.
2. Device expose to factory conditions <30°C/60% RH more than 672 hours.

Baking recommended condition: 60 ± 5°C for 20 hours.

For product information and a complete list of distributors, please go to our website: [www.avagotech.com](http://www.avagotech.com)

Avago, Avago Technologies, and the A logo are trademarks of Avago Technologies in the United States and other countries. Data subject to change. Copyright © 2005-2010 Avago Technologies. All rights reserved. Obsoletes 5989-0394EN AV02-2452EN - May 10, 2010

