

AFBR-1150L / AFBR-2150L

Fiber Optic Transmitter and Receiver for 150 Mbit/s MOST®

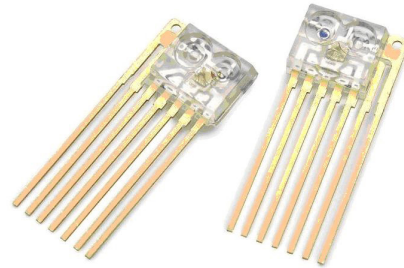

Data Sheet



Description

MOST150 transmitter and receiver are designed to transmit/ receive up to 150 MBit/s optical data which are DCA coded. Both are packaged in 7-pin transfer molded, low-cost packages ready for assembly into MOST® plastic fiber optic connector receptacles.

The transmitter utilizes a 650 nm LED source with integrated optics for efficient coupling into 1 mm Polymer Optical Fiber (POF), and the receiver contains a high speed PIN diode to receive this light.

Input/output data has LVDS switching levels, compatible with MOST® Network Interface Controller ICs.

These optical components are specified for operation over a -40 °C to +95 °C temperature range, and meet the reliability requirements of automotive applications. In the absence of data activity, transmitter and receiver switch to very low power mode. While in this mode, the devices can sense new data activity and switch back to full operation.

Related Documents

- MOST150 oPHY Automotive Physical Layer Sub-Specification

Features

- Optical transmitter and receiver for MOST150 applications with a maximum data rate of 150 Mbit/s
- 3.3 V power supply voltage
- Operating temperature range -40 °C to +95 °C
- Transmitter: driver IC and LED with 650 nm for working in low attenuation range of PMMA fiber, sleep- and wake-up-function, differential LVDS input stage.
- Receiver: photodiode and IC with pre-amp, post-amp, digitizer, sleep – and wake-up-function, differential LVDS output stage.
- Mechanical assembly: 7-pin transfer molded side-looker package with integrated lenses, 1.27 mm pitch between pin.
- Compliance to MOST150 oPHY Automotive Physical Layer Sub-Specification
- RoHS compliant (Lead free and halogen free)

Applications

Optical transmitter and receiver for MOST®150 Mbit/s systems (a full description of the MOST® 150 system is available at www.mostcooperation.com)

Absolute Maximum Ratings

Parameter	Symbol	Min.	Max.	Units
Supply Voltage ^[1]	V _{CCMax}	-0.5	4.0	V
Storage Temperature	T _{STG}	-40	105	°C
Soldering Temperature (Wave soldering) ^[2, 3]	T _{S-W}		260	°C
Soldering Temperature (Reflow soldering) ^[3]	T _{S-R}		250	°C
Voltage at any PIN		-0.5	V _{CC} +0.5	V
Electrostatic Voltage Capability ^[4]	ESD		2.0	kV

Notes:

1. Maximum supply voltage without causing damage
2. Distance to package >3mm; t_s≤10s
3. For more information regarding the solder process see Application Note Handling, Storage, Operating and Processing
4. ESD Capability for all Pins HBM (human body model) according JESD22-A114B

Recommended Operating Conditions

Parameter	Symbol	Min.	Typ.	Max.	Unit
Supply Voltage	V _{CC}	3.135	3.3	3.465	V
Data Rate DCA coded ^[5]	DR	135		150	Mbit/s
Ambient Temperature Range ^[6]	T _A	-40		95	°C

Notes:

5. Description of DCA coding in MOST150 oPHY Automotive Physical Layer Sub-Specification section 4.2 Network Coding
6. For more information see Application Note Handling, Storage, Operating and Processing

All the data in this specification refers to the operating conditions above and over lifetime unless otherwise stated.

AFBR-1150L (Transmitter)

Transmitter Electrical Characteristics

Parameter	Symbol	Min.	Typ. ^[7]	Max.	Unit
Supply Voltage	V _{CC}	3.135	3.3	3.465	V
Differential Input Voltage ^[8]	V _{DIN-DIFF}	100		600	mV
Input Voltage Range to Circuit Common ^[8]	V _{DIN}	0		2.4	V
DINP DINN Input Current	I _{DIN}			20	μA
Input High (/RST, -3dB)	V _{IH-LVC}	2		V _{CC} +0.3	V
Input Low (/RST, -3dB)	V _{IL-LVC}	-0.3		0.8	V
Current Consumption in Power On State	I _{FPM}		38 ²	52	mA
Current Consumption in Power Off State ^[9]	I _{LPM}		12 ²	30	μA

Notes:

7. Typical values at T = 25°C and V_{CC} = 3.30 V
8. All LVDS parameter have to fit LVDS specification TIA/EIA-644-A, absolute value of differential voltage, equal to single ended voltage level at each input DINP, DINN, input rise and fall times according the MOST[®] oPHY SP1 input eye.
9. /RST = Low and no input data

Transmitter Optical Signal Characteristics

Parameter	Symbol	Min.	Typ.	Max.	Unit
Optical Output Power (average) [1, 2]	P _{OPT}	-7.8		-1.5	dBm
Extinction Ratio	ER	10			dB
Optical Rise Time (20%-80%)	t _R			1.7	ns
Optical Fall Time (80%-20%)	t _F			1.7	ns
Center Wavelength [3]	λ _C	635	650	675	nm
Spectral Bandwidth RMS [3]	λ _W			17	nm
Transferred Jitter [4]	J _{TR}			112	ps RMS
Total Jitter [5, 6]	J _T		0.1 [8]	0.3	UI
Positive Overshoot [7]	OS			40	%
Negative Undershoot [7]	US	-20			%

Notes:

1. Average value when transmitting modulated light at signal timing parameters. The output power coupled into plastic fiber P_{opt} is measured with a large area detector at the end of 30 cm POF fiber with a NA = 0.5 which is ideally coupled to the transmitter.
2. MOST® Stress Pattern has been used for characterization
3. Center wavelength and spectral bandwidth RMS are defined as:

$$\lambda_C = \frac{\sum_{i=1}^N P_i \lambda_i}{\sum_{i=1}^N P_i}; \quad \lambda_W = \left(\left(\frac{\sum_{i=1}^N P_i \lambda_i^2}{\sum_{i=1}^N P_i} \right) - \lambda_C^2 \right)^{\frac{1}{2}}$$

Ref: EIA/TIA standard FOTP-127/61.1 and 61.3, 1991.

4. Using a Jitter Filter specified in MOST150 oPHY Automotive Physical Layer Sub-Specification section 5.2
5. Using a Golden PLL specified in MOST150 oPHY Automotive Physical Layer Sub-Specification section 5.1
6. Maximum allowed total jitter is derived from eye definition specified in MOST150 oPHY Automotive Physical Layer Sub-Specification section 6.2 (SP2). The total jitter at the electrical input of the Transmitter has to be < 0.15 UI.
7. Parameters are normalized and calculated relatively to the measured b₁ (top) and b₀ (base) levels, where b₁ = 100% and b₀ = 0%.
8. Typical jitter value is measured with MOST® stress pattern input signal with best possible jitter at typical conditions V_{CC} = 3.30 V, T = 25 °C

Transmitter Timing Characteristics

Parameter	Symbol	Min.	Typ.	Max.	Unit
Power On Delay	t _{ON}			100	μs
Power Off Delay	t _{OFF}			2	μs

Eye Safety

The transmitter device emits light with a wavelength of 650 nm (red). This product is designed to avoid damage to the unprotected eye. To indicate the classification of the light source, a label as depicted in the subsequent figure can be used. However these labels are not mandatory on the product according to IEC 60825 version 1.2 paragraph 1.1.

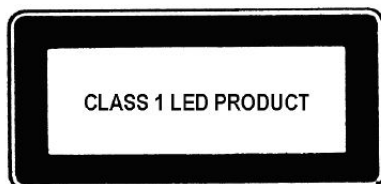

AFBR-2150L (Receiver)

Receiver Optical Input Signal Characteristics

Parameter	Symbol	Min.	Typ.	Max.	Unit
Average optical input power range for ON-state [1, 2]	P _{ON}	-22.5		-2	dBm
Average optical input power range for OFF-state [1]	P _{OFF}			-35	dBm
Center Wavelength [3]	λ _C	635	650	675	nm
Spectral Bandwidth RMS [3]	λ _W			17	nm

Notes:

- Optical power data are average values when using any MOST150 optical transmitter, measured at the end of a plastic optical fiber with metal insert (diameter 2.90 +/- 0.02 mm), which is ideally coupled to the receiver. The transmitter data is MOST® Stress Pattern.
- Within this optical power range the entire subsequent specifications are met and a BER ≤ 10⁻⁹ can be reached.
- Center wavelength and spectral bandwidth RMS are defined as:

$$\lambda_C = \frac{\sum_{i=1}^N P_i \lambda_i}{\sum_{i=1}^N P_i}; \quad \lambda_W = \left[\left(\frac{\sum_{i=1}^N P_i \lambda_i^2}{\sum_{i=1}^N P_i} \right) - \lambda_C^2 \right]^{\frac{1}{2}}$$

Ref: EIA/TIA standard FOTP-127/61.1 and 61.3, 1991.

Receiver Electrical Characteristics

Parameter	Symbol	Min.	Typ. [4]	Max.	Unit
Supply Voltage	V _{CC}	3.135	3.3	3.465	V
Differential Output Voltage [5]	V _{DO-DIFF}	250		400	mV
Output Offset Voltage [5]	V _{DO-OS}		1.2		V
Status Output Voltage High	V _{OH-STAT}	2.4			V
Status Output Voltage Low [6]	V _{OL-STAT}			0.4	V
Current Consumption in Power On State	I _{FPM}		21.5	35	mA
Current Consumption in Power Off State	I _{LPM}		1	30	μA
Electrical Rise Time (20%-80%) [5]	t _R			1.02	ns
Electrical Fall Time (80%-20%) [5]	t _F			1.02	ns
Transferred Jitter [7]	J _{TR}			230	ps RMS
Total Jitter [8, 9]	J _T		0.25 [10]	0.55	UI

Notes:

- Typical values at T = 25 °C and V_{CC} = 3.30 V
- The parameters of the LVDS data output are compliant to LVDS specification TIA/EIA-644-A
- For 8 kΩ pull up
- Using a Jitter Filter specified in MOST150 oPHY Automotive Physical Layer Sub-Specification section 5.2
- Using a Golden PLL specified in MOST150 oPHY Automotive Physical Layer Sub-Specification section 5.1
- Maximum allowed total jitter is derived from eye definition specified in [1] section 6.4 (SP4). The total jitter at the optical output of the Transmitter has to be < 0.30 UI. The optical signal may be sent through an attenuator and thereafter a max. 15 m POF (NA = 0.5) with a mode mixer.
- Typical jitter value is measured with MOST® stress pattern input signal with best possible jitter at typical conditions V_{CC} = 3.30 V, T = 25 °C and minimal P_{ON}

Receiver Timing Characteristics

Parameter	Symbol	Min.	Typ.	Max.	Unit
Power On Delay	t _{ON}			10	ms
Power Off Delay	t _{OFF}			1	ms

Package Dimensions

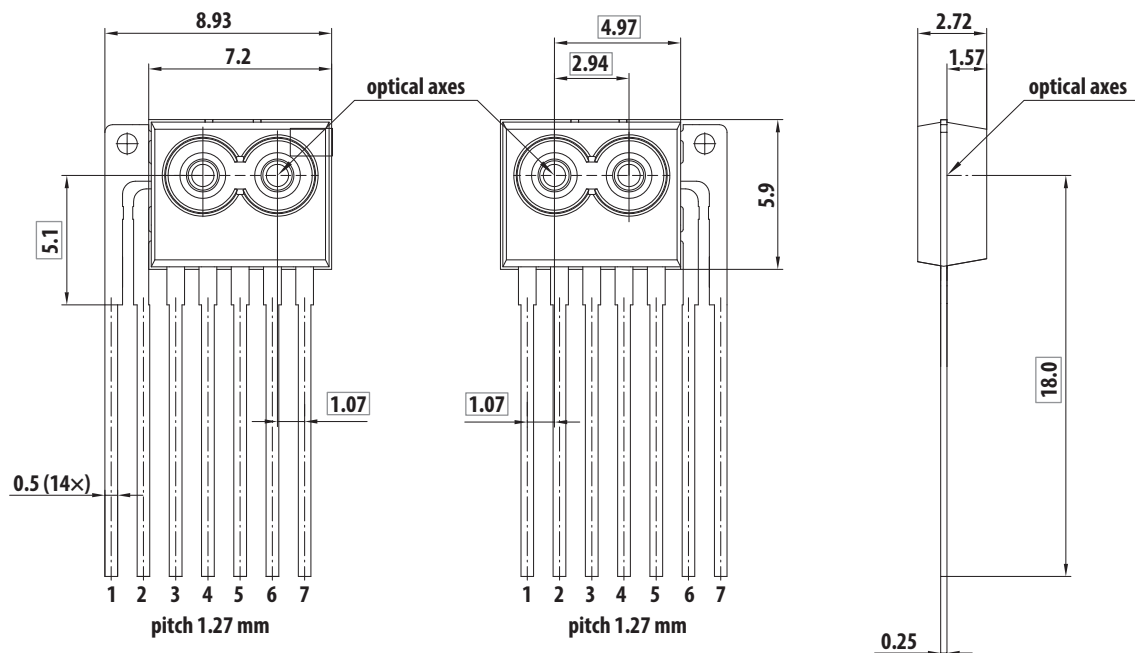

For more information see package outline drawing

Pin Description AFBR-1150L (Transmitter)

Pin	Pin-Name	Description
1	/RST	Reset, low active; LVCMOS input
2	REXT	Analog input for external reference resistor (10K 1%) to GND
3	DIN-	Negative TX data input, LVDS
4	DIN+	Positive TX data input, LVDS
5	GND	Power supply ground
6	VCC	Positive power supply, +3.3 V
7	-3DB	3dB reduced optical output power (must be high for > 4 ms)

Pin Description AFBR-2150L (Receiver)

Pin	Pin-Name	Description
1	STATUS	Optical signal detect indication Optical signal detected: Logic Low (0 V) No optical signal detected: Logic High (3 V)
2	VCC	Positive power supply, +3.3 V (must be connected)
3	GND	Power supply ground
4	DO-	Negative RX data output, LVDS
5	DO+	Positive RX data output, LVDS
6	REXT	Analog input for external reference resistor (47K 1%) to GND
7	VCC	Positive power supply, +3.3V (must be connected)

For product information and a complete list of distributors, please go to our web site: www.avagotech.com

Avago, Avago Technologies, and the A logo are trademarks of Avago Technologies in the United States and other countries. Data subject to change. Copyright © 2005-2015 Avago Technologies. All rights reserved.
AV02-2343EN - June 30, 2015

AVAGO
TECHNOLOGIES