

Avago Regulatory Guide to Isolation Circuits

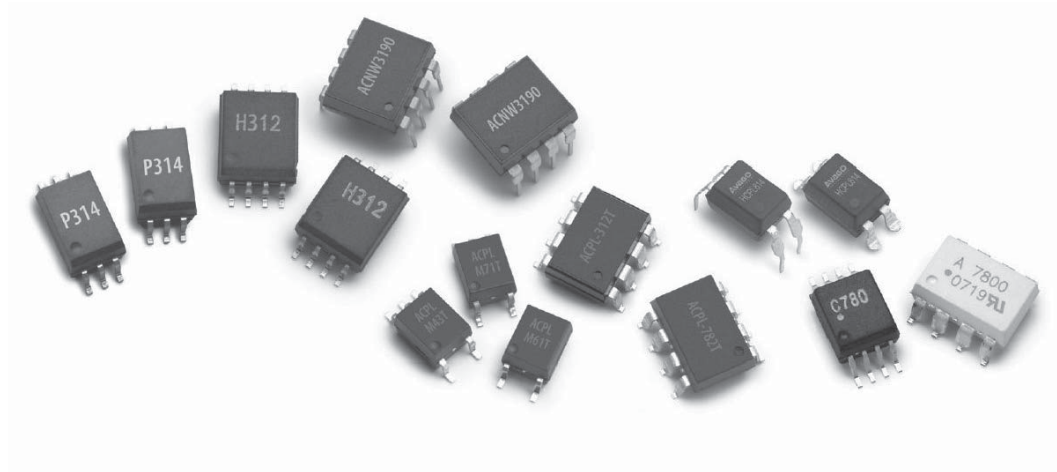

Dear Readers,

Avago Technologies does not in any way assume, either expressly or impliedly, any responsibility for the safety of the design or operation of any equipment that incorporates Avago optoisolators. The information herein illustrates the Avago optoisolators' safety standards including isolation coordinates and/or test voltages. The designers and manufacturers of equipment that incorporate Avago optoisolators must independently review their equipment's relevant safety features in light of the Avago optoisolators' safety features, including isolation coordinates and test voltages. Any warranties arising from Avago optoisolators shall be subjected to the sales agreement between Avago and its direct customers.

Avago Technologies sincerely hopes its optoisolators will meet or exceed your performance, quality and safety standards.

Table of Contents

Chapter 1 Introduction

1.1	Optoisolator Safety Standards and Regulatory Environment	4
1.2	Avago Technologies Optoisolator Safety Standards Information	6
1.3	General and Particular Safety Standards Specifications	10

Chapter 2 Avago Regulatory Standards Approved Optoisolators

2.0	Introduction.....	11
2.1	Avago Regulatory Standards Recognized Optoisolator	12
2.2	Avago IEC/EN/DIN EN 60747-5-5 Approved Optoisolator Ratings	16

Chapter 3 Avago Optoisolator Global Regulatory Standards Compliance Tables

3.0	How to Use the Regulatory Standards Compliance Tables.....	24
3.1	IEC 61010-1 Safety Standard Compliance Tables for Avago Optoisolators.....	25
3.2	EN 50178 or VDE 0160 Safety Standard Compliance Tables for Avago Optoisolators	27
3.3	IEC 60065 Safety Standard Compliance Tables for Avago Optoisolators.....	29
3.4	IEC 60601-1 Safety Standard Compliance Tables for Avago Optoisolators.....	30
3.5	IEC 60664-1 Insulation Coordination (Safety Standard) Compliance Tables for Avago Optoisolators	33
3.6	IEC 60950 Safety Standard Compliance Tables for Avago Optoisolators.....	35
3.7	UL 508 Safety Standard Compliance Tables for Avago Optoisolators	40
3.8	UL 840 Insulation Coordination (Safety Standard) Compliance Tablesfor Avago Optoisolators	44

Chapter 4 Synopsis of Key Regulatory Standards and Specifications

4.0	How to Use the Regulatory Synopsis Information.....	48
4.1	IEC 61010-1 Electrical Safety Requirements.....	49
4.2	EN 50178 or VDE 0160 Electrical Safety Requirements	52
4.3	IEC 60065 Electrical Safety Requirements.....	54
4.4	IEC 60601-1 Electrical Safety Requirements.....	56
4.5	IEC 60664-1 Insulation Coordination Safety Requirements	57
4.6	IEC 60950 Electrical Safety Requirements.....	62
4.7	UL 508 Electrical Safety Requirements.....	67
4.8	UL 840 Insulation Coordination Safety Requirements	71
4.9	IEC/EN/DIN EN 60747-5-5 Electrical Safety Standard for Optoisolators	75
4.10	UL 1577 Electrical Safety Standard for Optoisolators	83

Chapter 5 Appendices

5.1	Key Regulatory Standards Agencies and their Addresses.....	85
5.2	Bibliography.....	86
5.3	Glossary of Terms and Definitions.....	87
5.4	IEC Organization Mission and Objective	89
5.5	UL Organization Mission and Objective	90
5.6	VDE Organization Mission and Objective	91

Chapter 1. Introduction

1.1 Optoisolator Safety Standards and Regulatory Environment

Optoisolator applications often include environments where high voltages are present. The ability of the optoisolator or optocoupler to sustain and to isolate high voltages, both transient as well as working, is the driving reason why optocouplers are required in many designs. Equipment operators and circuits within equipment may need safe isolation and protection from high voltages. The safety performance of the optoisolator is determined during the design and the assembly of the product, so process control and design robustness are key to overall safety performance.

Because of the potential dangers of high voltage, optoisolators and the equipment in which they are used are often subject to safety standard regulations. The intent of these regulations is to offer additional security to the user and to provide guidelines to the industry on the application of high voltages. Given the large assortment of regulating organizations and the associated standards and specifications, regulatory compliance for optoisolator manufacturers and equipment suppliers can be confusing. In this regulatory guide, Avago Technologies shares some basic information which may help and facilitate regulatory and safety standards compliance.

The starting point of regulatory standards compliance is knowing the appropriate regulatory organization and its responsibility. Various regions of the world determine their individual standards and an organization in that country issues approvals or certificates for equipment and products. Since standards bodies have often begun as national organizations, many countries have their own regulatory environment. As international commerce grows there is a trend toward continental or international safety regulations and standards.

In Table 1.1, a short list of some important standards bodies are described. UL, CSA, and DKE have similar charters as national standards organizations. In general each body will have its own standards, and little overlap is visible between the related specifications. DKE authors DIN specifications; for historical reasons these specifications are often described as VDE (Verband Deutscher Elektrotechniker) standards. While VDE wrote the original version of these specifications, the responsibility for maintaining and developing German standards belongs to DKE. The DKE also represents and safeguards German interests within CENELEC and the IEC.

One of VDE's major roles is to be a standards test organization to certify products to the German standards. The VDE Testing and Certification institute is a neutral and independent body that carries out tests and issues certificates according to either VDE specifications or other acknowledged standards. TÜV (Technischer Überwachungs -Verein) is another organization that offers test certification to German and international standards. In other cases, such as UL or CSA, the organization that authors the documents is also the organization that grants recognition or certification. Most of the organizations can be described as Standards Writing Bodies and Third Party Certifiers, and not as "regulatory bodies". The International Electrotechnical Commission (IEC) develops standards and supports the IEC CB (competent bodies) program. This is a program to allow exchange of test data and certifications from third party certifications organizations participating in the CB program.

Table 1.1 Regulatory Standards Organizations

Organization Name	Charter
CENELEC (European Committee for Electrotechnical Standardization)	Harmonizing of European Standards
UL (Underwriters Laboratories, Inc.)	U.S. Standards
IEC (International Electrotechnical Commission)	International Electronic Standards
CSA (Canadian Standards Assoc.)	Canadian Standards
DKE (Deutscher Elektrotechnische Kommission)	German Standards

IEC is an international organization comprising fifty national organizations, and is the only truly global electronics standards organization. European Committee for Electrotechnical Standardization (CENELEC) was created to minimize or eliminate regulatory complexities associated with pan-European Union. The “CE” stamp is granted by CENELEC. The CENELEC specifications, which are European Norm (EN) documents, are often leveraged from existing documents from organizations such as IEC.

These regulatory or standards organizations write specifications for each major piece of equipment or component type. For a single product, worldwide regulatory approval can involve each regulatory standards organization and separate equipment level specification requirements.

Table 1.2 is a cross reference of various specifications by the respective regulatory organizations for major applications. These specifications are written at the equipment level. Each equipment specification is a master document, but many subordinate specifications are referenced to complete the total requirements. Subordinate documents are critical to certification, but not identified inside Table 1.2. Besides the equipment level specifications, Table 1.3 shows the important specifications for the optoisolator components. The equipment level specification can reference the component level specification as a subordinate document, or there may be no connection at all between equipment and component level specifications. More detailed information regarding selected equipment and component specifications are presented in accompanying sections.

Table 1.2 Application Versus Global / Regional Safety Standards

Application	International	Europe	U.S.	Canada	Germany
Organization	IEC	CENELEC (EN)	UL*	CSA**	DIN/VDE
Industrial	60204	50178	508	14-M91	–
Information Technology Equipment	60950	60950	60950	60950	60950
Medical	60601	60601	2601-1	601	750
Household	60065	60065	8730-1		860
Measurement and Control	61010-1	61010-1	1262	1010	0410 0411
Telecom	60950	60950 41003	1459	225	804

* See UL catalog, *Standards for Safety*, for specific equipment standards.

** See Canadian Electrical Code for specific equipment standards.

Table 1.3 Optoisolator Component Level Specifications

Component	International	Europe	U.S.	Canada	Germany
Organization	IEC	CENELEC (EN)	UL	CSA	DIN/VDE
Optoisolator	IEC 60747-5-5	EN 60747-5-5	1577	Component Acceptance Notice 5A	DIN EN 60747-5-5

1.2 Avago Technologies Optoisolator Safety Information

Avago Technologies (Avago) offers a wide range of optoisolator products, package styles, and product options to satisfy safety and regulatory standards requirements. Many safety and regulatory features, such as spacing and high voltage performance, are included in the products' design, and categorized by the package type. Equivalent electrical functions are offered in most package styles.

For the purposes of this regulatory guide, the package styles offered by Avago Technologies can be split into the groups indicated in Table 1.4, and package styles will be referenced to this grouping in this guide where appropriate.

400 mil Widebody 8-Pin DIP Package (Group A) –

This product group offers the highest level of safety and regulatory performance available today. This wide body package has 400 mil lead spacing to satisfy demanding external creepage and clearance requirements. The UL/CSA Viso rating is 5000 V rms (1 minute), and the IEC/EN/DIN EN 60747-5-5 working voltage specification is 1414 V peak. The construction has 1 mm of internal clearance (through insulation distance) and 10 mm of external creepage, and 9.6 mm of external clearance (see Table 1.4). Optoisolator products in this group have a nomenclature scheme of A/HCNWXXXX or HCNRXXXX, where XXXX stands for a particular device type.

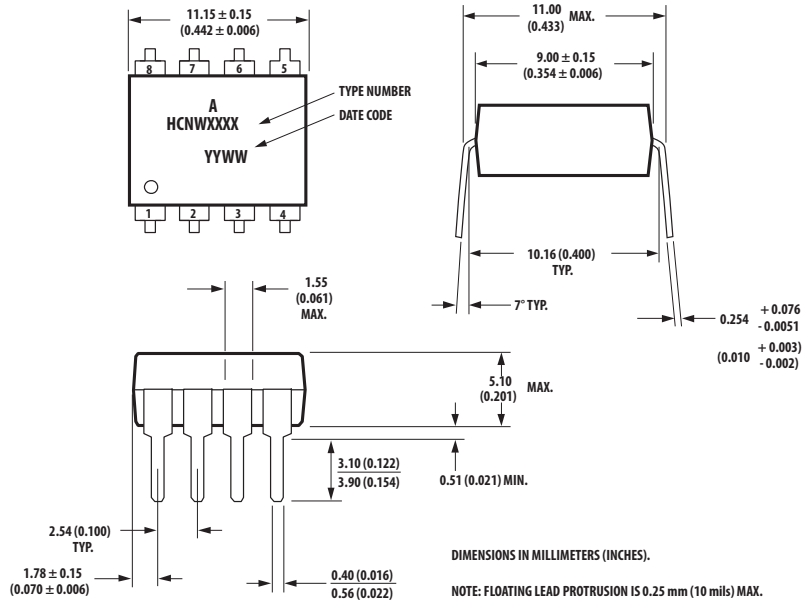

Fig. 1.2.1 400 mil Widebody 8-Pin DIP Outline Drawing

SO-16 Surface Mount Package and 300 mil 8-Pin DIP Package (Group B) –

These products offer standard UL/CSA/VDE certifications in the SO-16 Surface Mount Package and 300 mil DIP package. The UL/CSA Viso rating for this package style is 3750 V rms (1 minute). The IEC/EN/DIN EN 60747-5-5 working voltage rating is 891 V_{peak} for the SO-16 package and HCPL-JXXX of the 8-pin DIP package, and 848 V_{peak} for HCPL-7XXX of the 8-pin DIP package. The package construction includes a 0.5 mm of internal clearance (through insulation distance). Products in this group have a nomenclature scheme of A/HCPL-XXXJ, HCPL-JXXX and HCPL-7XXX. (See Table 1.4).

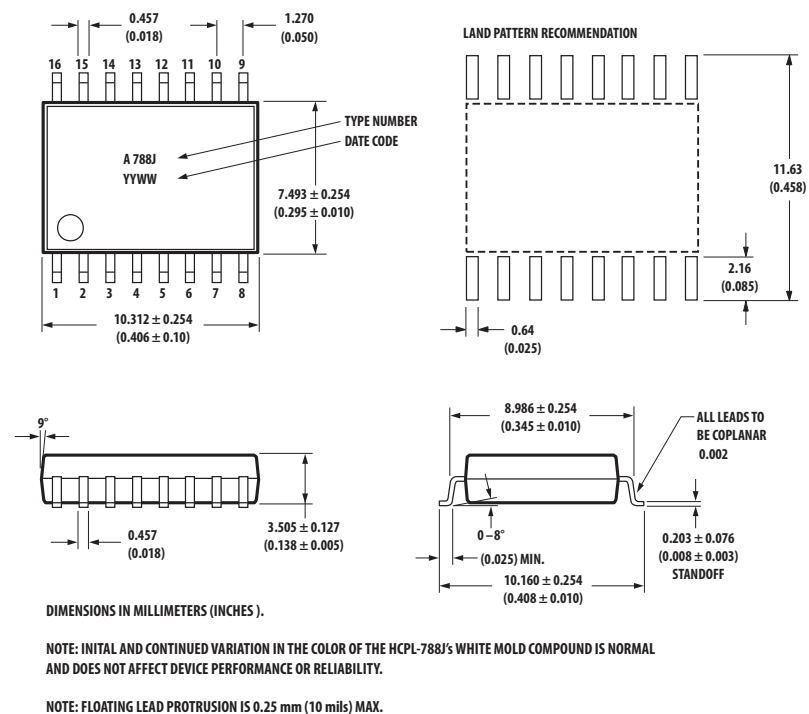

Fig. 1.2.2 SO-16 Package Outline Drawing

300 mil DIP (Group C) –

This product group has standard certification to UL and CSA of Viso = 3750 V rms (1 minute), and has option #060 for IEC/EN/DIN EN 60747-5-5 with a 630 V peak working voltage or option #020 for a UL/CSA Viso rating of 5000 V rms (1 minute). Outline drawing for this package is shown in Figure 1.2.2. Optoisolator products in this group have a nomenclature scheme of A/HCPL-XXXX (See Table 1.4).

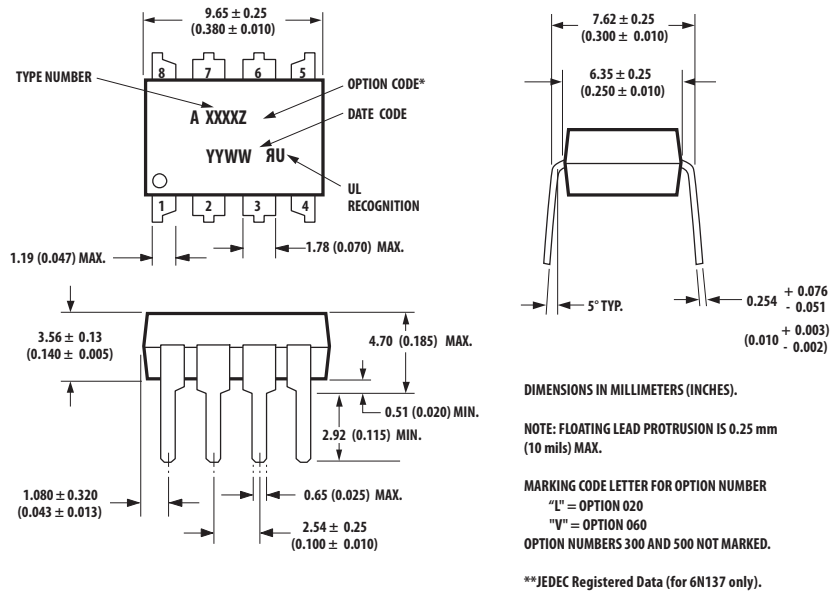

Fig. 1.2.3 300 mil DIP Outline Drawing

SO-8 Surface Mount Package (Group D) –

These smaller standard surface mount products include UL and CSA standard Viso rating of 3750 V rms (1 minute) as well as option #060 for TÜV (Technischer Überwachungs - Verein) approvals at 560 V peak working voltage per IEC/EN/DIN EN 60747-5-5. Table 1.5 summarizes the various working and transient voltage capabilities for Avago's optoisolator products. Optoisolator products in this group have a nomenclature scheme of A/HCPL-0XXX.

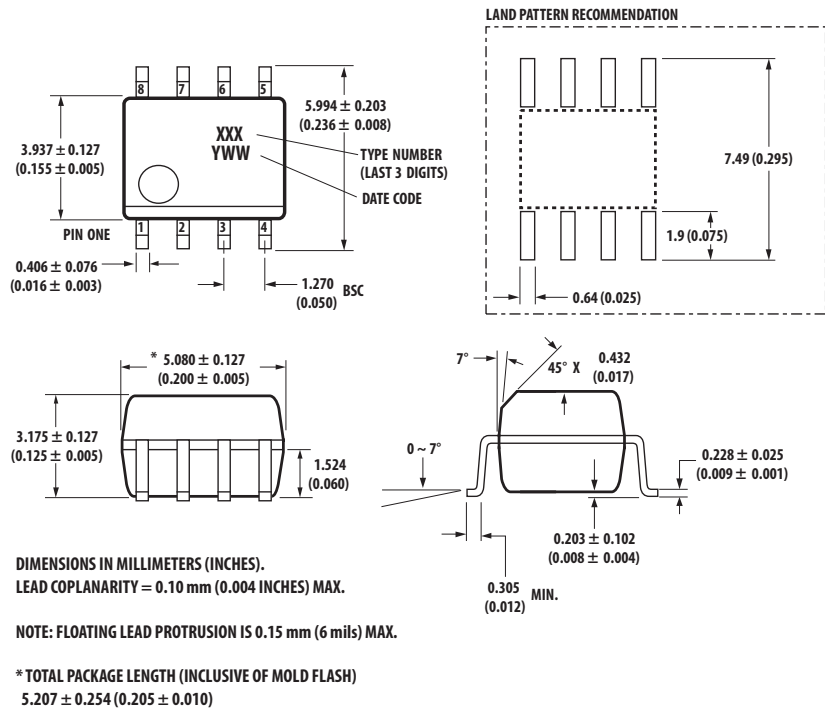

Fig. 1.2.4 SO-8 Package Outline Drawing

SO-5 Surface Mount Package (Group E) –

These smaller standard surface mount products include UL and CSA standard Viso rating of 3750 Vrms (1 minute) as well as option #060 for TÜV (Technischer Überwachungs - Verein) approvals at 560 V peak working voltage per IEC/EN/DIN EN 60747-5-5. Table 1.5 summarizes the various working and transient voltage capabilities for Avago's optoisolator products. Optoisolator products in this group have a nomenclature scheme of A/HCPL-MXXX. (See Table 1.4)

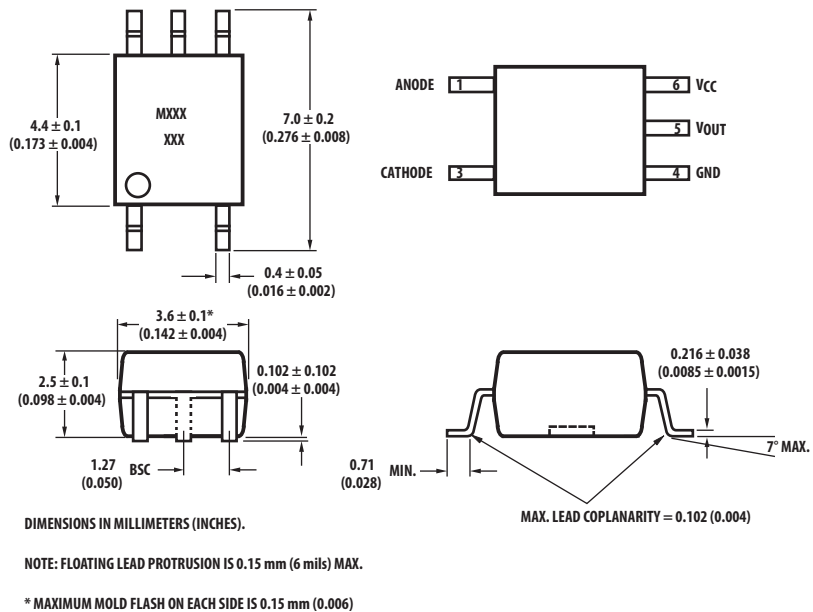

Fig. 1.2.5 SO-5 Outline Drawing

Stretch SO-8 & SO-6 Surface Mount Package (Group F) –

These smaller standard surface mount products include UL and CSA standard Viso rating of 3750 Vrms (1 minute) as well as option #060 for TÜV (Technischer Überwachungs - Verein) approvals at 891 V peak working voltage per IEC/EN/DIN EN 60747-5-5. Table 1.5 summarizes the various working and transient voltage capabilities for Avago's optoisolator products. Optoisolator products in this group have a nomenclature scheme of ACPL-PXXX/HXXX.

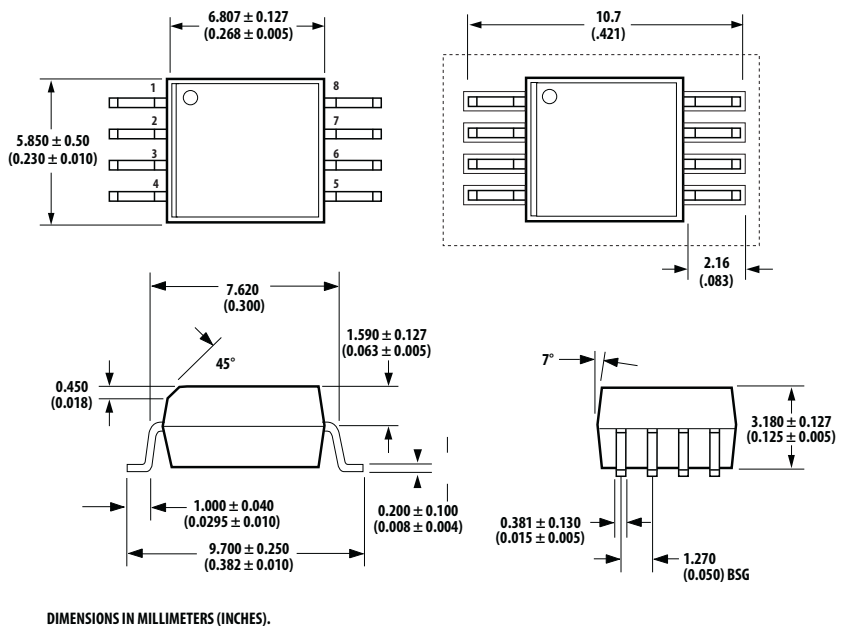

Fig. 1.2.6 Stretch SO-8 Package Outline Drawing

Stretch SO-8 & SO-6 Surface Mount Package (Group G) –

These smaller standard surface mount products include UL and CSA standard Viso rating of 3750 Vrms (1 minute) as well as option #060 for TÜV (Technischer Überwachungs – Verein) approvals at 1140 V peak working voltage per IEC/EN/DIN EN 60747-5-5. Table 1.5 summarizes the various working and transient voltage capabilities for Avago’s optoisolator products. Optoisolator products in this group have a nomenclature scheme of ACPL-KXXX/WXXX.

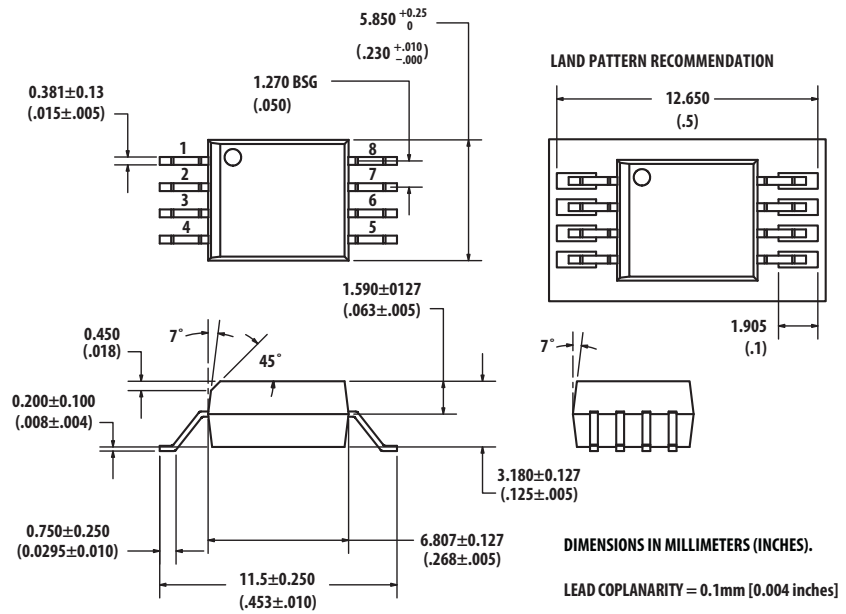

Fig. 1.2.7 Stretch SO-8 Package Outline Drawing

Table 1.4 Creepage and Clearance Data

Package Style	Group Designation	External Creepage (mm)	External clearance (mm)	Internal Clearance (mm)
400 mil DIP	Group A	10	9.6	1.0
SO-16 (HCPL-XXXJ)	Group B	8.0	7.4	0.5
300 mil DIP (HCPL-JXXX)		8.3	8.3	
300 mil DIP	Group C	7.4	7.1	0.08
SO-8	Group D	4.8	4.9	0.08
SO-5	Group E	5.0	5.0	0.08
Stretch SO-8 / SO-6 (ACPL-H/PXXX)	Group F	8.0	7.0	0.08
Stretch SO-8 / SO-6 (ACPL-K/WXXX)	Group G	8.0	8.0	0.08

Table 1.5 Working Voltage and Transient Voltage Data

Package Style	Group Designation	Viso (1 min proof test)	IEC/EN/DIN EN 60747-5-5 Working Voltage Vpeak	IEC/EN/DIN EN 60747-5-5 Transient Overvoltage Vpeak
400 mil DIP	Group A	5000	1414	8000
SO-16 (HCPL-XXXJ)	Group B	3750	891 / 848	6000
300 mil DIP (HCPL-JXXX)				
300 mil DIP	Group C	3750 (standard) 5000 (#020)	630 (#060)	8000
SO-8	Group D	3750	560 (#060)	6000
SO-5	Group E	3750	560 (#060)	6000
Stretch SO-8 / SO-6 (ACPL-H/PXXX)	Group F	3750	891	6000
Stretch SO-8 / SO-6 (ACPL-K/WXXX)	Group G	3750	1140	8000

Table 1.6 Avago Optoisolator Nomenclature Scheme

Package Style	Group Designation	Nomenclature Scheme
400 mil DIP	Group A	HCNWXXXX/ACNWXXX HCNRXXX
300 mil DIP SO-16	Group B	HCPL-7XXXX HCPL-JXXX HCPL-XXXJ
300 mil DIP	Group C	HCPL-XXXX
SO-8	Group D	HCPL-0XXX
SO-5	Group E	HCPL-MXXX
Stretch SO-8 / SO-6	Group F	ACPL-H/PXXX
Stretch SO-8 / SO-6	Group G	ACPL-K/WXXX

The intent of this safety standards regulatory guide is to provide comprehensive information regarding safety standards certifications and compliance of Avago optoisolator components. In addition, various equipment level standards have been summarized in this guide. For equipment level standards, Avago does not in any way claim or imply that Avago Optoisolator components are approved to these standards. Normally, equipment manufacturers need to have their equipment approved to various equipment level safety standards. Avago has interpreted the standards to show Table 1.6 Avago Optoisolator Nomenclature Scheme compliance to the safety standards applicable to its optoisolator components, and does not in any shape or form take any responsibility or liability for equipment level standards or approvals related to Avago optoisolator components.

1.3 General vs. Particular Standards

Safety and regulatory standards are either at the component level or at the equipment level. However,

within a particular equipment application or industry segment, the standards can be separated further into general standards and particular standards.

General standards address the safety and regulatory specifications of a wide application class of an industrial segment. There may be hundreds of equipment types in a particular industrial segment, and some of this equipment may have safety requirements not captured in a general standard. The purpose of a product specific or particular standard is to further elaborate and capture those additional requirements that were not included in the general standard.

For example, in the medical electrical equipment industry, the IEC general safety requirements are covered under the general standard IEC 60601-1. There are approximately 34 particular standards covering various medical equipment. Table 1.7 lists just a small number of IEC and VDE particular standards to illustrate this point.

Table 1.7 General versus Particular Standards

Organization	Standard	Description
IEC	60601-1	General requirements for safety of medical electrical equipment
IEC	60601-2-6	Particular requirements for the safety of microwave therapy equipment
IEC	60601-2-25	Particular requirements for the safety of electrocardiographs
VDE	0700-700	General requirements for safety of household appliances
VDE	0700 Teil 7	Particular requirements for washing machines
VDE	0700 Teil 24	Particular requirements for refrigerating appliances, Ice cream and ice

Chapter 2. Avago Regulatory Standards Approved Optoisolators

2.0 Introduction

This chapter contains a comprehensive summary of the global regulatory standards approved Avago Technologies Optoisolators. Table 2.1 is a complete list of Avago Optoisolators available at the time of publication of this guide. The intent of this chapter is to help and facilitate selection of an opto-isolator that will meet the safety standards requirements as defined by the user or required by an application.

Table 2.1 indicates the safety standards approvals from the various component level global regulatory agencies. This table also indicates the isolation coordinates as defined per IEC 60664-1 (creepage, clearance, and through insulation distance) associated with the package types of each of the optoisolators offered.

Table 2.2 is a summary of the IEC/EN/DIN EN 60747-5-5 approval ratings for the various package types available from Avago Technologies. This table lists the key parameters associated with the component level ratings and approvals of the optoisolators from the German regulatory agencies VDE (Verband Deutscher Elektrotechniker) and TÜV. From this table one can extract the Maximum Working Insulation Voltage, which is the maximum continuous operating voltage that an optoisolator can be subjected to without risk of potential or actual failure or degradation of the optoisolator insulation. This table also indicates the overvoltage categories or installation classes associated and approved for the various optoisolator package types.

Table 2.1 defines Avago Technologies IEC/EN/DIN EN 60747-5-5 optocouplers in seven groups, namely Groups (A, B, C, D, E, F and G). This grouping is based on package

styles. Group A is a 400 mil 8-pin wide body package. Groups B and C are 300 mil 8-pin DIP. Group D, F and G are a small Outline surface mount SO-8 package. Group E is a mini-flat/SO 5 pin package. Group F and G are SO Stretch packages.

Table 2.1 is also an Avago Technologies optoisolator construction and mechanical ratings information table. This table shows the internal construction for the various optoisolator product package groups defined as groups (A, B, C, D, E, F and G). In addition, this table defines and indicates the creepage, clearance, and through insulation distance. This table indicates only the key optoisolator package dimensions of width, height, and length. For complete package dimensions and details, please see the individual data sheets, or see section 1.2 for the package outline drawings.

It is noted that UL and CSA rate optoisolators on the basis of their dielectric withstand voltage (Viso) capability, regardless of creepage, clearance, and through insulation dimension. The IEC/EN/DIN EN 60747-5-5 ratings, however, are based upon a non-destructive insulation test method called partial discharge. The ratings for the partial discharge voltage limits are based on the dielectric strength of the insulation material in addition to the geometry of the optoisolator (creepage and clearance) obtained from DIN/VDE 0110, part 1 (01.89). Creepage tables determine the maximum allowable working voltage (continuous operating voltage across the isolation barrier of the optoisolator). Clearance tables provide guidance for the maximum allowable transient overvoltage.

Table 2.1 Avago Regulatory Standards Recognized and Approved Optoisolators

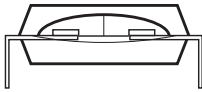
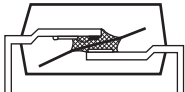
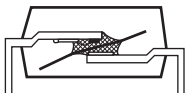
Product Group	Part Number	UL1577/CSA Notice 5		IEC/EN/DIN EN	External Creepage	External Clearance	Through Insulation
		3750	5000	60747-5-5	(mm) min	(mm) min	(mm) min
		Vrms (1 minute)		V peak			
 <p>See Figures g and n for package dimensions</p>	HCNR200		X	1414*	10.0	9.6	1.0
	HCNR201		X	1414*	10.0	9.6	1.0
	HCNW135		X	1414	10.0	9.6	1.0
	HCNW136		X	1414	10.0	9.6	1.0
	HCNW137		X	1414	10.0	9.6	1.0
	HCNW138		X	1414	10.0	9.6	1.0
	HCNW139		X	1414	10.0	9.6	1.0
	HCNW2201		X	1414	10.0	9.6	1.0
	HCNW2211		X	1414	10.0	9.6	1.0
	HCNW2601		X	1414	10.0	9.6	1.0
	HCNW2611		X	1414	10.0	9.6	1.0
	HCNW3120		X	1414	10.0	9.6	1.0
	HCNW4502		X	1414	10.0	9.6	1.0
	HCNW4503		X	1414	10.0	9.6	1.0
	HCNW4504		X	1414	10.0	9.6	1.0
HCNW4506		X	1414	10.0	9.6	1.0	
HCNW4562		X	1414	10.0	9.6	1.0	
 <p>See Figures h and o for package dimensions</p>	HCPL-314J	X		891	8.3	8.3	0.5
	HCPL-315J	X		891	8.3	8.3	0.5
	HCPL-316J	X		891	8.3	8.3	0.5
	HCPL-7510	X		891	8.0	7.4	0.5
	HCPL-7520	X		891	8.0	7.4	0.5
	HCPL-7800	X		891	8.0	7.4	0.5
	HCPL-7800A	X		891	8.0	7.4	0.5
	HCPL-7840	X		891	8.0	7.4	0.5
	HCPL-7860	X		891	8.0	7.4	0.5
	HCPL-786J	X		891	8.3	8.3	0.5
	HCPL-788J	X		891	8.3	8.3	0.5
	HCPL-J312	X		891	8.0	7.4	0.5
	HCPL-J314	X		891	8.0	7.4	0.5
	HCPL-J454	X		891	8.0	7.4	0.5
HCPL-J456	X		891	8.0	7.4	0.5	
 <p>See Figures i and p for package dimensions</p>	4N45	X		630	7.4	7.1	0.08
	4N46	X		630	7.4	7.1	0.08
	6N135	X	X**	630	7.4	7.1	0.08
	6N136	X	X**	630	7.4	7.1	0.08
	6N137	X	X**	630	7.4	7.1	0.08
	6N138	X	X**	630	7.4	7.1	0.08
	6N139	X	X**	630	7.4	7.1	0.08

Notes:

* Option 050 for IEC/EN/DIN EN 60747-5-5 approved parts for the HCNR200/HCNR201.

** Option 020 for the UL1577 5000 Vrms/1 minute (Option 060 and 020 not available in same package).

*** Order option 060 for IEC/EN/DIN EN 60747-5-5 630 Vpeak.

1. Group B contains two groups of optocouplers, DIP 8 and SO-16 white mould compound packages. These two groups have been lumped in one group based on the similarity of their safety standard capabilities. However, their internal construction is dissimilar.
2. Group D contains two groups of optocouplers, SO-8 and SO-5 surface mount packages. These two groups have been lumped in one group based on the similarity of their safety standard capabilities. However, their internal construction is dissimilar.
3. Contact your local Avago Sales Representative concerning availability of regulatory approval for optocouplers not listed.

Table 2.1 Avago Regulatory Standards Recognized and Approved Optoisolators (continued)

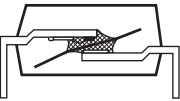
Product Group	Part Number	UL1577/CSA Notice 5		IEC/EN/DIN EN 60747-5-5 V peak	External Creepage (mm) min	External Clearance (mm) min	Through Insulation (mm) min
		3750 Vrms (1 minute)	5000 Vrms (1 minute)				
Group C, cont.  See Figures i and p for package dimensions	HCPL-3020	X		630	7.4	7.1	0.08
	HCPL-3120	X		630	7.4	7.1	0.08
	HCPL-3140	X		630	7.4	7.1	0.08
	HCPL-3150	X		630	7.4	7.1	0.08
	HCPL-3700	X		630	7.4	7.1	0.08
	HCPL-3760	X		630	7.4	7.1	0.08
	HCPL-4100	X		630	7.4	7.1	0.08
	HCPL-4200	X		630	7.4	7.1	0.08
	HCPL-4502	X	X**	630	7.4	7.1	0.08
	HCPL-4503	X	X**	630	7.4	7.1	0.08
	HCPL-4504	X	X**	630	7.4	7.1	0.08
	HCPL-4506	X	X**	630	7.4	7.1	0.08
	HCPL-4534	X	X**	630	7.4	7.1	0.08
	HCPL-4562	X	X**	630	7.4	7.1	0.08
	HCPL-4661	X	X**	630	7.4	7.1	0.08
	HCPL-4701	X	X**	630	7.4	7.1	0.08
	HCPL-4731	X	X**	630	7.4	7.1	0.08
	HCPL-7710	X		630	7.4	7.1	0.08
	HCPL-7720	X		630	7.4	7.1	0.08
	HCPL-7721	X		630	7.4	7.1	0.08
	HCPL-7723	X		630	7.4	7.1	0.08
HCPL-T250	X		630	7.4	7.1	0.08	
HCPL-T251	X		630	7.4	7.1	0.08	

Notes:

** Option 020 for the UL1577 5000 Vrms/1 minute (Option 060 and 020 not available in same package).

*** Order option 060 for IEC/EN/DIN EN 60747-5-5 630 Vpeak.

1. Group B contains two groups of optocouplers, DIP 8 and SO-16 white mould compound packages. These two groups have been lumped in one group based on the similarity of their safety standard capabilities. However, their internal construction is dissimilar.
2. Group D contains two groups of optocouplers, SO-8 and SO-5 surface mount packages. These two groups have been lumped in one group on the similarity of their safety standard capabilities. However, their internal construction is dissimilar.
3. Contact your local Avago Sales Representative concerning availability of regulatory approval for optocouplers not listed.

Table 2.1 Avago Regulatory Standards Recognized and Approved Optoisolators (continued)

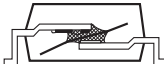
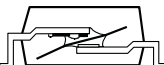
Product Group	Part Number	UL1577/CSA Notice 5		IEC/EN/DIN EN	External Creepage	External Clearance	Through Insulation
		3750	5000	60747-5-5	(mm) min	(mm) min	(mm) min
		Vrms (1 minute)		V peak			
<p>Group D</p>  <p>See Figures j and q for package dimensions</p>	HCPL-0201	X		560	4.8	4.9	0.08
	HCPL-0211	X		560	4.8	4.9	0.08
	HCPL-0300	X		560	4.8	4.9	0.08
	HCPL-0302	X		560	4.8	4.9	0.08
	HCPL-0314	X		560	4.8	4.9	0.08
	HCPL-0452	X		560	4.8	4.9	0.08
	HCPL-0453	X		560	4.8	4.9	0.08
	HCPL-0454	X		560	4.8	4.9	0.08
	HCPL-0466	X		560	4.8	4.9	0.08
	HCPL-0500	X		560	4.8	4.9	0.08
	HCPL-0501	X		560	4.8	4.9	0.08
	HCPL-050L	X		560	4.8	4.9	0.08
	HCPL-0530	X		560	4.8	4.9	0.08
	HCPL-0531	X		560	4.8	4.9	0.08
	HCPL-0534	X		560	4.8	4.9	0.08
	HCPL-053L	X		560	4.8	4.9	0.08
	HCPL-0600	X		560	4.8	4.9	0.08
	HCPL-0601	X		560	4.8	4.9	0.08
	HCPL-060L	X		560	4.8	4.9	0.08
	HCPL-0611	X		560	4.8	4.9	0.08
	HCPL-061A	X		560	4.8	4.9	0.08
	HCPL-061N	X		560	4.8	4.9	0.08
	HCPL-0630	X		560	4.8	4.9	0.08
	HCPL-0631	X		560	4.8	4.9	0.08
	HCPL-0635	X		560	4.8	4.9	0.08
	HCPL-063A	X		560	4.8	4.9	0.08
	HCPL-063L	X		560	4.8	4.9	0.08
	HCPL-063N	X		560	4.8	4.9	0.08
	HCPL-0661	X		560	4.8	4.9	0.08
	HCPL-0700	X		560	4.8	4.9	0.08
	HCPL-0701	X		560	4.8	4.9	0.08
	HCPL-0708	X		560	4.8	4.9	0.08
	HCPL-070A	X		560	4.8	4.9	0.08
	HCPL-070L	X		560	4.8	4.9	0.08
HCPL-0710	X		560	4.8	4.9	0.08	
HCPL-0720	X		560	4.8	4.9	0.08	
HCPL-0721	X		560	4.8	4.9	0.08	
HCPL-0723	X		560	4.8	4.9	0.08	
HCPL-0730	X		560	4.8	4.9	0.08	
HCPL-0731	X		560	4.8	4.9	0.08	
HCPL-073A	X		560	4.8	4.9	0.08	
HCPL-073L	X		560	4.8	4.9	0.08	
<p>Group E</p>  <p>See Figures k and r for package dimensions</p>	HCPL-M452	X		560	5.0	5.0	0.08
	HCPL-M453	X		560	5.0	5.0	0.08
	HCPL-M454	X		560	5.0	5.0	0.08
	HCPL-M456	X		560	5.0	5.0	0.08
	HCPL-M600	X		560	5.0	5.0	0.08
	HCPL-M601	X		560	5.0	5.0	0.08
	HCPL-M611	X		560	5.0	5.0	0.08
	HCPL-M61A	X		560	5.0	5.0	0.08
	HCPL-M61N	X		560	5.0	5.0	0.08
	HCPL-M700	X		560	5.0	5.0	0.08
HCPL-M701	X		560	5.0	5.0	0.08	

Notes:

*** Order option 060 for IEC/EN/DIN EN 60747-5-5 560 Vpeak.

1. Group B contains two groups of optocouplers, DIP 8 and SO-16 white mould compound packages. These two groups have been lumped in one group based on the similarity of their safety standard capabilities. However, their internal construction is dissimilar.
2. Group D contains two groups of optocouplers, SO-8 and SO-5 surface mount packages. These two groups have been lumped in one group based on the similarity of their safety standard capabilities. However, their internal construction is dissimilar.
3. Contact your local Avago Sales Representative concerning availability of regulatory approval for optocouplers not listed.

Table 2.1 Avago Regulatory Standards Recognized and Approved Optoisolators (continued)

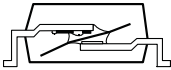
Product Group	Part Number	UL1577/CSA Notice 5		IEC/EN/DIN EN 60747-5-5 V peak	External Creepage (mm) min	External Clearance (mm) min	Through Insulation (mm) min
		3750 Vrms (1 minute)	5000				
Group F & G  See Figures l and s as well as m and t for package dimensions	ACPL-P302	X	X	891	8.0	7.0	0.08
	ACPL-P314	X	X	891	8.0	7.0	0.08
	ACPL-P454	X	X	891	8.0	7.0	0.08
	ACPL-P456	X	X	891	8.0	7.0	0.08
	ACPL-P480	X	X	891	8.0	7.0	0.08
	ACPL-P611	X	X	891	8.0	7.0	0.08
	ACPL-H312	X	X	891	8.0	7.0	0.08
	ACPL-W302	X	X	891	8.0	8.0	0.08
	ACPL-W312	X	X	1140	8.0	8.0	0.08
	ACPL-W454	X	X	1140	8.0	8.0	0.08
	ACPL-W60L	X	X	1140	8.0	8.0	0.08
	ACPL-W611	X	X	1140	8.0	8.0	0.08
	ACPL-W70L	X	X	1140	8.0	8.0	0.08
	ACPL-K453	X	X	1140	8.0	8.0	0.08
	ACPL-K63L	X	X	1140	8.0	8.0	0.08
	ACPL-K73L	X	X	1140	8.0	8.0	0.08
	ACPL-C780	X	X	1140	8.0	8.0	0.5
	ACPL-C78A	X	X	1140	8.0	8.0	0.5
	ACPL-C784	X	X	1140	8.0	8.0	0.5

Notes:

*** Order option 060 for IEC/EN/DIN EN 60747-5-5 891 Vpeak.

1. Group B contains two groups of optocouplers, DIP 8 and SO-16 white mould compound packages. These two groups have been lumped in one group based on the similarity of their safety standard capabilities. However, their internal construction is dissimilar.
2. Group D contains two groups of optocouplers, SO-8 and SO-5 surface mount packages. These two groups have been lumped in one group based on the similarity of their safety standard capabilities. However, their internal construction is dissimilar.
3. Contact your local Avago Sales Representative concerning availability of regulatory approval for optocouplers not listed.

Table 2.2 Avago Technologies IEC/EN/DIN EN 60747-5-5 Approved Optoisolator Ratings

Description	Symbols	IEC/EN/DIN EN 60747-5-5							Unit
		Group A	Group B	Group C	Group D	Group E	Group F	Group G	
Installation Classification		I – III							
Rated Mains Line Voltage < 1000 Vrms		I – III							
Rated Mains Line Voltage < 600 Vrms		I – IV	I – III	I – III	I – II	I – II	I – III	I – III	
Rated Mains Line Voltage < 300 Vrms			I – IV	I – IV	I – III	I – III	I – IV	I – IV	
Rated Mains Line Voltage < 150 Vrms					I – IV	I – IV			
Climatic Classification		55/100/21	55/100/21	55/100/21	55/100/21	55/100/21	55/100/21	55/105/21	
Pollution Degree		2	2	2	2	2	2	2	
Maximum Working Insulation Voltage	Virom	1414	891	630	560	560	891	1140	Vpeak
Production Input to Output Test Voltage 1 second, Vpr = 1.875 x Virom, Partial Discharge < 5pC	Vpr	2652	1671	1181	1050	1050	1671	2137	Vpeak
Qualification Input to Output Test Voltage, 10 seconds, Vm = 1.6 x Virom, Partial Discharge < 5pC	Vm	2262	1426	1008	896	896	1426	1824	Vpeak
Maximum Transient Overvoltage, tini = 60 seconds Qualification test	Viotm	8000	6000	8000	6000	6000	6000	8000	Vpeak
Comparative Tracking Index	CTI	200	175	175	175	175	175	175	V
Material Group		IIIa	IIIa	IIIa	IIIa	IIIa	IIIa	IIIa	
Insulation Resistance @ Tsi = 25degC, Vio = 500V	Rs	10 ⁹	10 ⁹	10 ⁹	10 ⁹	10 ⁹	10 ⁹	10 ⁹	ohm
Safety Limiting Ratings									
Maximum package/case temperature	Ts	150	175	175	150	150	175	175	C
Maximum LED Input Current	Is	400	80	230	150	150	230	230	mA
Maximum Detector Power Dissipation	Ps	700	250	600	600	600	600	600	mW

Package Cross-sections

(Note: These are pictorial cross-sections and are not to scale.)

GROUP A (HCNW/HCNR)
400 MIL 8-PIN DIP
(WIDE BODY PACKAGE)

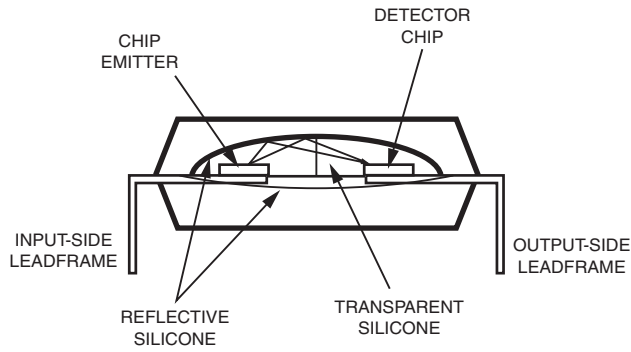

Figure (a)

GROUP B HCPL-JXXX / XXXJ / 7XXX
300 MIL 8-PIN DIP
and SO-16

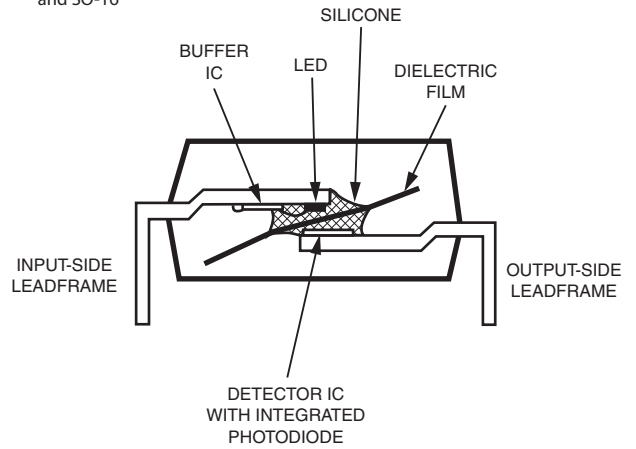

Figure (b)

GROUP C
300 MIL 8-PIN DIP PACKAGE

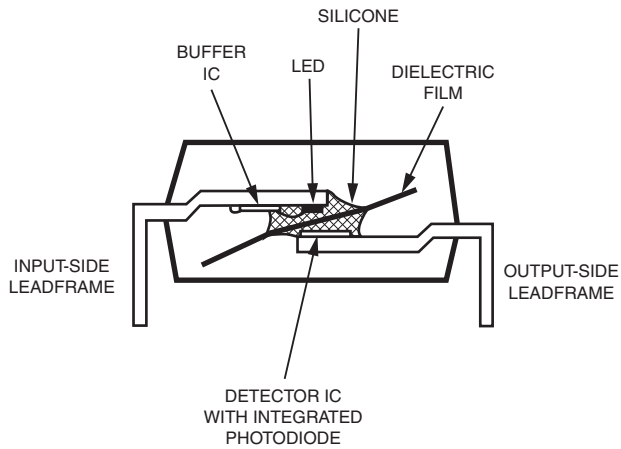

Figure (c)

GROUP D: SO-8
SMALL OUTLINE
SURFACE MOUNT PACKAGE

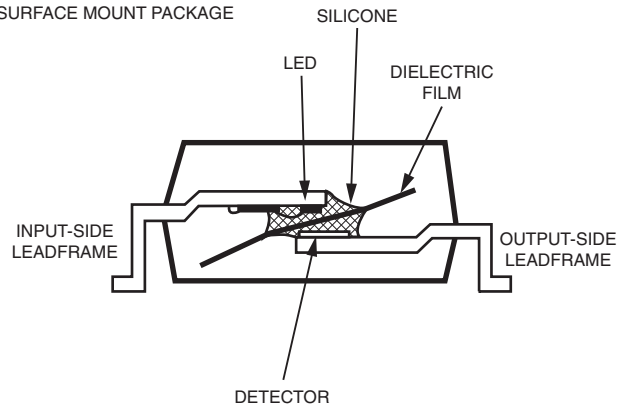

Figure (d)

Package Cross-sections

(Note: These are pictorial cross-sections and are not to scale.)

GROUP E: SO-5
SMALL OUTLINE
SURFACE MOUNT PACKAGE

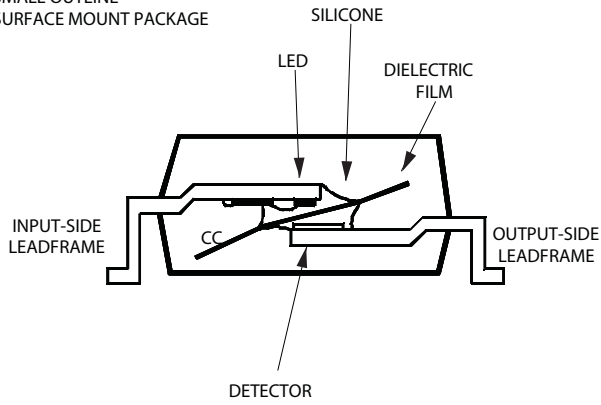

Figure (e)

GROUP F & G: Stretch SO-8
SMALL OUTLINE
SURFACE MOUNT PACKAGE

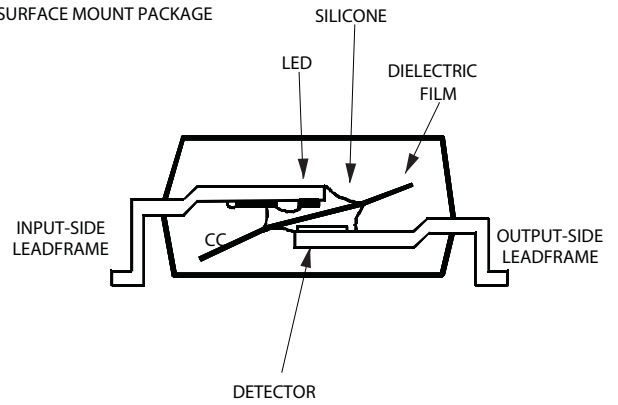
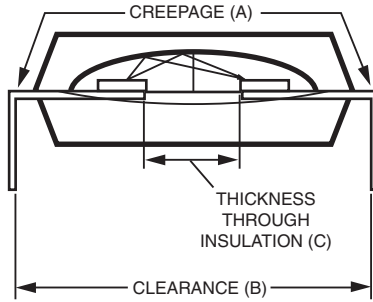

Figure (f)

Creepage and Clearance

(See Note 1 on page 21.)

GROUP A: HCNW
(WIDE BODY PACKAGE)



A = 10 mm
B = 9.6 mm
C = 1 mm

Figure (g)

GROUP B:
HCPL-XXXJ / JXXX / 7XXX

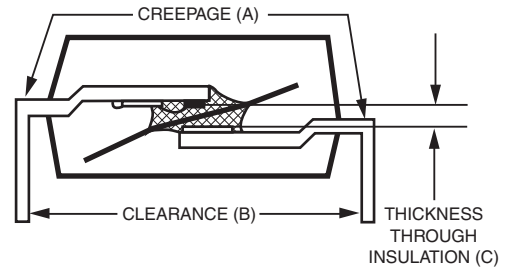

	HCPL-XXXJ	HCPL-JXXX
A	8.3 mm	8 mm
B	8.3 mm	7.4 mm
C	0.5 mm	0.5 mm

Figure (h)

GROUP C: 8-PIN DIP

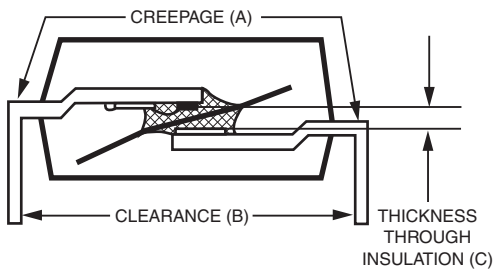

A = 7.4 mm
B = 7.1 mm
C = 0.08 mm

Figure (i)

GROUP D: SO-8

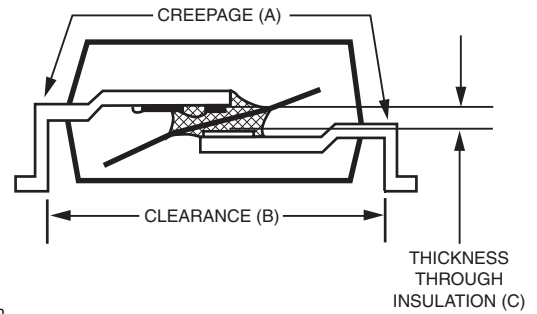

A = 4.8 mm
B = 4.9 mm
C = 0.08 mm

Figure (j)

Creepage and Clearance

(See Note 1 on page 21.)

GROUP E: SO-5

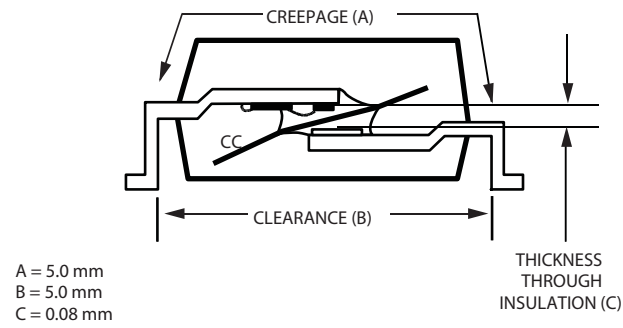

Figure (k)

GROUP F: Stretch SO-8 (ACPL-H/PXXX)

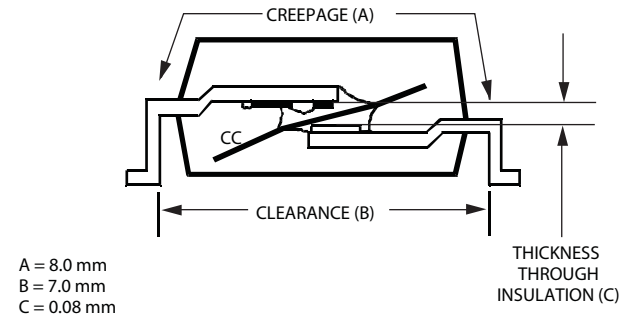

Figure (l)

GROUP G: Stretch SO-8 (ACPLK/WXXX)

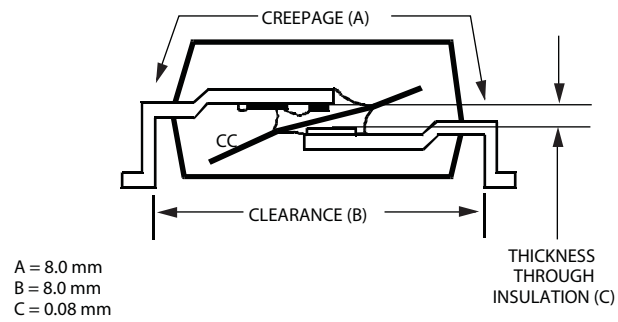

Figure (m)

Package Dimensions

GROUP A: HCNW/HCNR
(WIDE BODY PACKAGE)

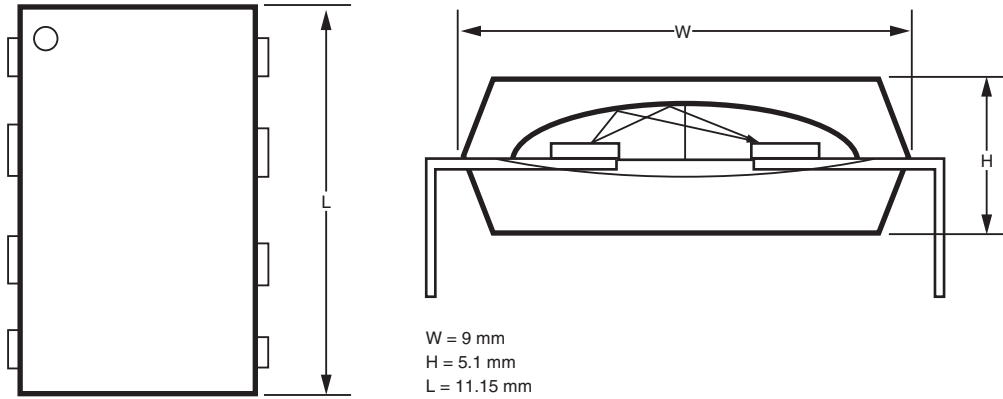

Figure (n)

GROUP B GROUP B

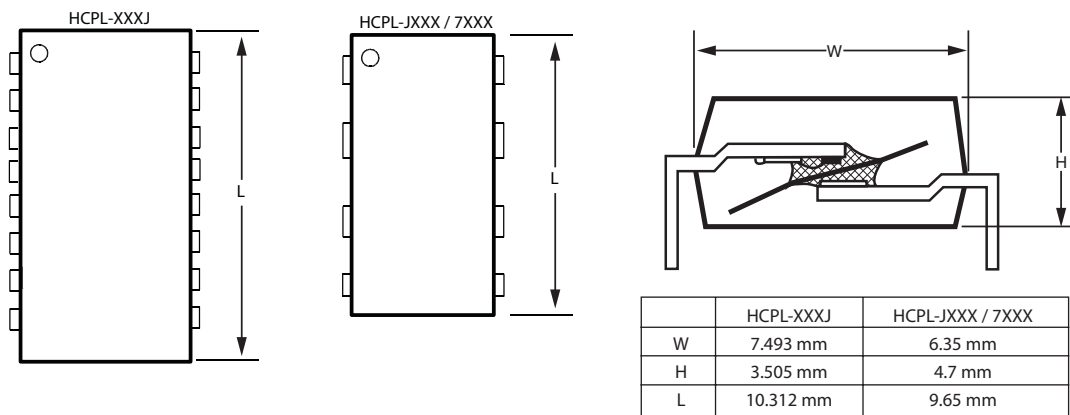

Figure (o)

GROUP C: 8 PIN DIP

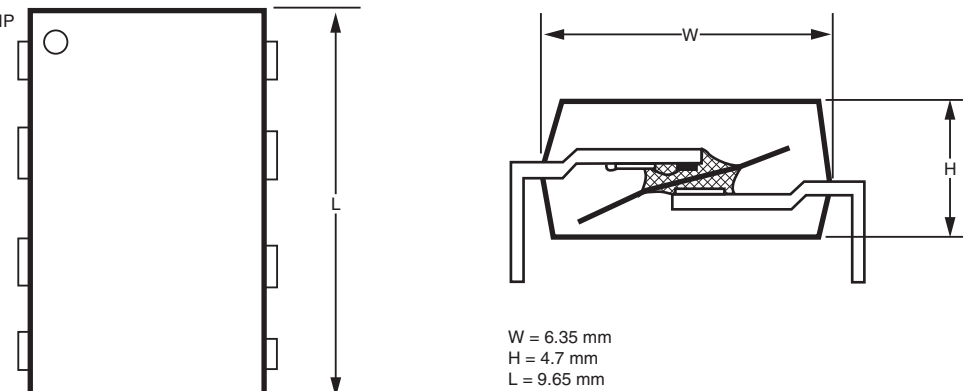

Figure (p)

GROUP D: SO-8

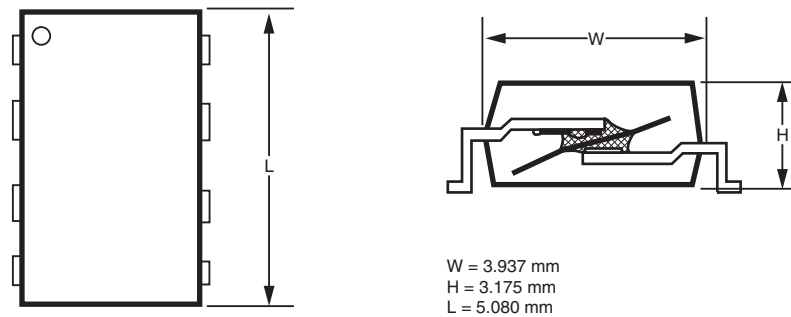
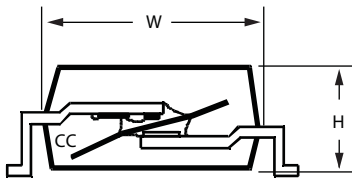
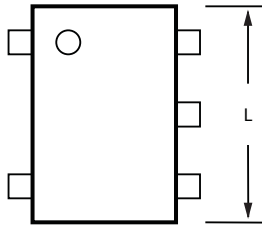

Figure (q)

Package Dimensions

GROUP E SO-5



W = 4.4 mm
H = 2.5 mm
L = 3.6 mm

Figure (r)

GROUP F: Stretch SO-8
(ACPL-H/PXXX)

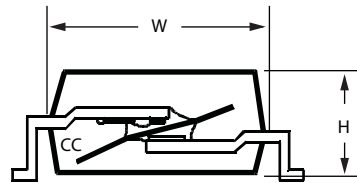
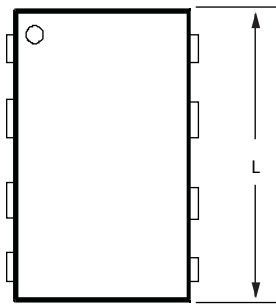

W = 6.81 mm
H = 3.18 mm
L = 5.85 mm

Figure (s)

GROUP G: Stretch SO-8
(ACPL-W/KXXX)

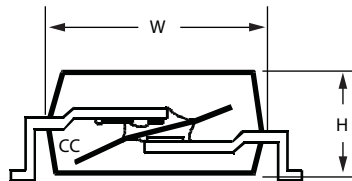
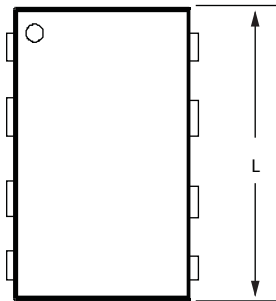

W = 6.81 mm
H = 3.18 mm
L = 5.85 mm

Figure (t)

Note 1:

Creepage and Clearance

All Avago Technologies data sheets report the external creepage, external clearance and internal clearance inherent to the optoisolator component itself. These dimensions are needed as a starting point for the equipment designer when determining the circuit insulation requirements. See Table 1.4.

External creepage is the shortest distance path along the surface of the insulation, i.e., along the surface of an optoisolator body between the input and output leads. For Avago Technologies optoisolators, the shortest distance path is found around the end of the package body. See Figure 2.1.

External clearance is the shortest distance path through air, between two conductive leads, input to output, as shown in Figure 2.2.

Internal clearance (distance through insulation), as applied to optoisolators, is the direct distance between the photoemitter and photodetector inside the optoisolator cavity. Some equipment standards require a minimum **0.4 mm** distance through insulation for reinforced levels.

However, once mounted on a printed circuit board, minimum external creepage and clearance requirements must be met as specified for individual equipment standards. For creepage, the shortest distance path along the surface of a printed circuit board between the solder fillets of the input and output leads must be considered. There are recommended techniques such as grooves and ribs which may be used on a printed circuit board to achieve desired creepage and clearances. Creepage and clearance distance requirements will also change depending on factors such as pollution degree and insulation level.

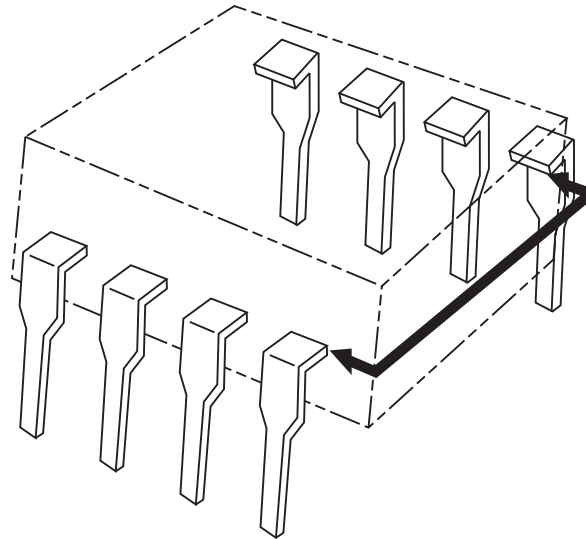

Figure 2.1 External Creepage.

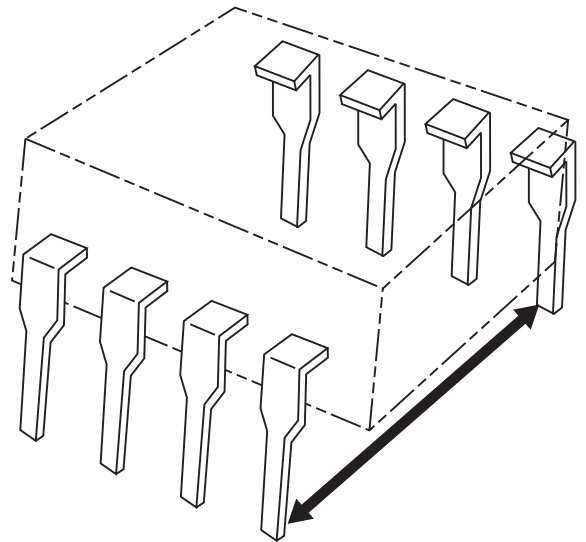

Figure 2.2 External Clearance.

Chapter 3. Avago Optoisolators Global Regulatory Compliance Tables

3.0 How To Use The Regulatory Compliance Tables

The compliance tables contained in this chapter are designed to help and facilitate you, the designer, to quickly and easily determine if a certain Avago Optoisolator Product Group or Product satisfies the isolation coordinates (creepage, clearance, through distance insulation) and test voltage requirements of a particular international and/or national safety standard. These tables display safety compliance information of Avago Optoisolator products, and compliance information is shown for various equipment level safety standards and also some insulation coordination safety standards.

Avago Optoisolator Product Groups have been defined in these tables as the following groups:

Group A – 400 mil Widebody DIP Package – This product group starts with HCNW or HCNR prefix (e.g HCNW139 or HCNR200).

Group B – 300 mil DIP Package – This product group starts with HCPL-7XXX, HCPL-JXXX, or HCPL-XXXJ marking scheme (e.g. HCPL-7840).

Group C – 300 mil DIP Package – This product group includes any Avago Optoisolator with the marking scheme HCPL-XXXX (e.g. HCPL-2611 or HCPL-2400).

Group D – SO-8 Package – This product group includes surface mount products in the SO-8 package. This group has a nomenclature scheme of HCPL-OXXX (e.g. HCPL-0701 or HCPL-0631).

Group E – SO-5 Package – This product group includes surface mount products in mini-flat package. This product group starts with HCPL-MXXX (e.g. HCPLM501)

Group F & G – Stretch SO-8 or SO-6 package – These product group includes surface mount products in the SO-8 or SO-6 package. These groups have a nomenclature scheme of ACPLHXXX/PXXX/KXXX/WXXX (e.g. ACPL-H312 or ACPL-K312).

Table 2.1 is a comprehensive listing of all the Optoisolators available from Avago Technologies. One way to utilize the compliance information would be to select the Avago Optoisolator that you need from Table 2.1 first, and then reconcile the regulatory standard compliance information provided in this chapter. Conversely, one can first look at compliance information for an Avago

Optoisolator Product Group vis-à-vis a safety standard of interest, and then pick an Optoisolator that meets your application requirements from Table 2.1.

Product compliance to a safety standard typically entails reconciling the requirements of each of the compliance tables for creepage, clearance and test voltages, before one can establish if the product in question meets or fully complies with a safety standard's safety criteria. Compliance is shown in the tables contained in this chapter for each of the insulation coordinates independent of each other. In order to establish if a compliance as a whole exists for a safety standard, one needs to look at the compliance table for each insulation coordinate to establish an overall compliance for a particular safety standard.

Avago Technologies does not in any way imply or assume responsibility for equipment level safety standards approvals for its optoisolator product groups. The information provided is an interpretation for compliance of Avago Optoisolators to the isolation coordinates and/or test voltages of some safety standards of interest and substance. Avago does not claim any equipment level standards approval of its optoisolator components. Avago does not assume any responsibility for any liability issues that may arise from the use of any information provided in this guide. It is the equipment manufacturer's responsibility to establish equipment level safety standards approval.

Compliance information for Avago's optoisolator products is provided as a service to Avago's optoisolator customers. We hope this information will assuage and mitigate the difficulty that customers face to determine and establish if an Avago optoisolator will meet or exceed a safety standard's insulation coordinate parameters or criteria. Table 2.1 lists the component level safety standards that Avago optoisolators are approved or recognized by.

For any additional information, questions, or comments about this "Regulatory Guide to Isolation Circuits", please contact Avago Technologies.

For further Optoisolator and Regulatory information, please visit the Avago web site.

3.1 Avago Optoisolator Compliance Summary for IEC 61010-1

Reconciliation of the IEC 61010-1 requirements for Creepage, Clearance, and Test voltages, as shown in Tables (3.1, 3.2, 3.3) indicates that Avago Technologies Optoisolator product groups will comply with the standards requirements under the following cases. Only a few cases are considered as examples, and the reader can readily interpret other cases by considering the compliance shown in the Tables (3.1, 3.2, 3.3):

a) For installation category II and pollution degree 2 environment, Avago Optoisolator product groups (A, B, C (option 020)) will comply with the IEC 61010-1 requirements at a working voltage of 1000 V rms or dc at the basic insulation level.

b) For installation category II and pollution degree 2 environment, Avago Optoisolator product groups (A, B, C, D) will comply with the IEC 61010-1 requirements at a working voltage of 300 V rms or dc, or lower, at either basic or reinforced insulation level.

c) For installation category II and pollution degree 2 environment, Avago Optoisolator product groups (A, B, C, D) will comply with the IEC 61010-1 requirements at a working voltage of 600 V rms or dc, at the basic insulation level, and product groups [A, B, C (option 020)] will comply at a working voltage of 600 V rms or dc at the reinforced insulation level.

Table 3.1 IEC 61010-1 Creepage / Clearance Compliance

Avago Optoisolator Product Groups*

Safety Requirements for Electrical Equipment for Measurement, Control, and Laboratory Use

Working Voltage V rms or dc	Insulation Level	Overvoltage Category [I]	Overvoltage Category [II]	Overvoltage Category [III]
		Pollution Degree 1		
< 150	Basic	A, B, C, D, E, F, G	A, B, C, D, E, F, G	A, B, C, D, E, F, G
	Reinforced	A, B, C, D, E, F, G	A, B, C, D, E, F, G	A, B, C, D, E, F, G
300	Basic	A, B, C, D, E, F, G	A, B, C, D, E, F, G	A, B, C, D, E, F, G
	Reinforced	A, B, C, D, E, F, G	A, B, C, D, E, F, G	A, B, C
600	Basic	A, B, C, D, E, F, G	A, B, C, D, E, F, G	A, B, C
	Reinforced	A, B, C, D, E, F, G	A, B, C	
1000	Basic	A, B, C, D, E, F, G	A, B, C	A
	Reinforced	A, B, C		

* NOTES:

- See Table 2.1 for Avago Optoisolator Product Groups:
 Group A = 400 mil Widebody Package (HCNW/HCNR),
 Group B = 300 mil DIP Package (HCPL-7XXX/JXXX) and SO-16 package (HCPL-XXXJ),
 Group C = 300 mil DIP Package (HCPL-XXXX),
 Group D = SO-8 Package.
 Group E = SO-5 Package.
 Group F & G = Stretch SO Packages.
- Material Group = IIIa.
- Avago Optoisolator Products mapped for IEC 61010-1 Creepage/Clearance values on Printed Wiring Boards (Not Coated).
- Reconcile requirements of each compliance Table (3.1, 3.2, 3.3) for product compliance to the IEC 61010-1 safety standard.

**Table 3.2 IEC 61010-1 Creepage / Clearance Compliance
Avago Optoisolator Product Groups*
Safety Requirements for Electrical Equipment for Measurement, Control, and Laboratory Use**

Working Voltage V rms or dc	Insulation Level	Installation Category [I]	Installation Category [II]	Installation Category [III]
		Pollution Degree 2		
< 150	Basic	A, B, C, D, E, F, G	A, B, C, D, E, F, G	A, B, C, D, E, F, G
	Reinforced	A, B, C, D, E, F, G	A, B, C, D, E, F, G	A, B, C, D, E, F, G
300	Basic	A, B, C, D, E, F, G	A, B, C, D, E, F, G	A, B, C, D, E, F, G
	Reinforced	A, B, C, D, E, F, G	A, B, C, D, E, F, G	A, B, C
600	Basic	A, B, C, D, E, F, G	A, B, C, D, E, F, G	A, B, C
	Reinforced	A, B, C	A, B, C	
1000	Basic	A, B, C	A, B, C	A
	Reinforced	A		

* NOTES:

- See Table 2.1 for Avago Optoisolator Product Groups:
Group A = 400 mil Widebody Package (H/ACNW/HCNR),
Group B = 300 mil DIP Package (HCPL-7XXX/JXXX) and SO-16 package (HCPL-XXXJ),
Group C = 300 mil DIP Package (HCPL-XXXX),
Group D = SO-8 Package.
Group E = SO-5 Package.
Groups F & G = SO Stretch Package.
- Material Group = IIIa.
- Avago Optoisolator Products mapped for IEC 61010-1 Creepage/Clearance values on Printed Wiring Boards (Not Coated)
- Reconcile requirements of each compliance Table (3.1, 3.2, 3.3) for product compliance to the IEC 61010-1 safety standard.

**Table 3.3 IEC 61010-1 Test Voltage Compliance
Avago Optoisolator Product Groups*
Safety Requirements for Electrical Equipment for Measurement, Control, and Laboratory Use**

Working Voltage V rms or dc	Insulation Level	Installation Category [I]	Installation Category [II]	Installation Category [III]
		Pollution Degree 1 or 2		
< 150	Basic	A, B, C, D, E, F, G	A, B, C, D, E, F, G	A, B, C, D, E, F, G
	Reinforced	A, B, C, D, E, F, G	A, B, C, D, E, F, G	A, B, C, D, E, F, G
300	Basic	A, B, C, D, E, F, G	A, B, C, D, E, F, G	A, B, C, D, E, F, G
	Reinforced	A, B, C, D, E, F, G	A, B, C, D, E, F, G	A, B, C**
600	Basic	A, B, C, D, E, F, G	A, B, C, D, E, F, G	A, B, C**
	Reinforced	A, B, C, D, E, F, G	A, B, C**	
1000	Basic	A, B, C, D, E, F, G	A, B, C**	A
	Reinforced	A, B, C**		

* NOTES:

- See Table 2.1 for Avago Optoisolator Product Groups:
Group A = 400 mil Widebody Package (HCNW/HCNR),
Group B = 300 mil DIP Package (HCPL-7XXX/JXXX) and SO-16 package (HCPL-XXXJ),
Group C = 300 mil DIP Package (HCPL-XXXX),
Group D = SO-8 Package.
Group E = SO-5 Package.
Group F & G = Stretch SO Packages.
- Material Group IIIa.
- Avago Optoisolators mapped per IEC 1010-1 Test Voltage option identified by V rms /1 minute (50/60 Hz) and compliance is based UL ratings.
- **4. Group C here includes only option 020 (5000 Vrms/1min, UL) parts"
- Reconcile requirements of each compliance Table (3.1, 3.2, 3.3) for product compliance to the IEC 601010 -1 safety standard.

3.2 Avago Optoisolator Compliance Summary for VDE 0160 / EN 50178

Reconciliation of the VDE 0160 / EN 50178 requirements for Creepage, Clearance, and Test voltages, as shown in Tables (3.4, 3.5, 3.6) indicates that Avago Technologies Optoisolator product groups will comply with the standards requirements under the following cases. Only a few cases are considered as examples, and the reader can readily interpret other cases by considering the compliance shown in the Tables (3.4, 3.5, 3.6):

a) For installation category II and pollution degree 2 environment, Avago Optoisolator product groups (A, B) will comply with the VDE 0160 / EN 50178 requirements at a working voltage of 400 V rms or dc at the reinforced insulation level. Only group (A) will meet the working voltage requirements at 500 V rms or dc under similar conditions.

b) For installation category II and pollution degree 2 environment, Avago Optoisolator product groups (A, B, C, D) will comply with the VDE 0160 / EN 50178 requirements at a working voltage of 400 V rms or dc, or lower, at basic insulation level.

c) For installation category II and pollution degree 2 environment, Avago Optoisolator product groups (A, B, C) will comply with the VDE 0160 / EN 50178 requirements at a working voltage of 630 V rms or dc, at the basic insulation level.

(Note: VDC 0160 had been withdrawn)

**Table 3.4 VDE 0160 / EN 50178 Clearance Compliance
Avago Optoisolator Product Groups*
Safety Requirements for Electrical Equipment for use in Electrical Power Installations**

LINE Voltage V rms or dc	Insulation Level	Installation Category II	Installation Category III
		Pollution Degree 2	
120-540 V Single Phase	Basic	A, B, C, D, E, F, G	A, B, C, D, E, F, G
	Reinforced	A, B, C, D, E, F, G	A, B, C, D, E, F, G
up to 277 V 3 Phase	Basic	A, B, C, D, E, F, G	A, B, C, D, E, F, G
	Reinforced	A, B, C, D, E, F, G	A, B, C
up to 400 V 3 Phase	Basic	A, B, C, D, E, F, G	A, B, C
	Reinforced	A, B, C	A
1000 V	Basic	A, B, C	A
	Reinforced	A	

* NOTES:

- See Table 2.1 for Avago Optoisolator Product Groups:
Group A = 400 mil Widebody Package (H/ACNW / HCNR),
Group B = 300 mil DIP Package (HCPL-7XXX / JXXX) and SO-16 package (HCPL-XXXJ),
Group C = 300 mil DIP Package (HCPL-XXXX),
Group D = SO-8 Package.
Group E = SO-5 Package.
Group F & G = Stretch SO Packages.
- Material Group = IIIa, Pollution degree = 2.
- Avago Optoisolator Product Groups mapped for VDE 0160 / EN 50178 Clearance Requirements on Printed Circuit Boards
- Reconcile requirements of each compliance Table (3.4, 3.5, 3.6) for product compliance to the VDE 0160 / EN 50178 safety standard.

Table 3.5 VDE 0160 / EN 50178 Creepage Compliance
Avago Optoisolator Product Groups*
Safety Requirements for Electrical Equipment for use in Electrical Power Installations

Working Voltage V rms or dc	Insulation Level	Pollution Degree 2
200	Basic	A, B, C, D, E, F, G
	Reinforced	A, B, C, D, E, F, G
250	Basic	A, B, C, D, E, F, G
	Reinforced	A, B, C
320	Basic	A, B, C, D, E, F, G
	Reinforced	A, B, C
400	Basic	A, B, C, D, E, F, G
	Reinforced	A, B
500	Basic	A, B, C
	Reinforced	A
630	Basic	A, B, C
	Reinforced	
800	Basic	A
	Reinforced	
1000	Basic	A
	Reinforced	

* NOTES:

- See Table 2.1 for Avago Optoisolator Product Groups:
 Group A = 400 mil Widebody Package (H/ACNW / HCNR),
 Group B = 300 mil DIP Package (HCPL-7XXX /JXXX) and SO-16 package (HCPL-XXXJ),
 Group C = 300 mil DIP Package (HCPL-XXXX),
 Group D = SO-8 Package.
 Group E = SO-5 Package.
 Group F & G = Stretch SO Packages.
- Material Group = IIIa, Pollution degree = 2.
- Avago Optoisolator Product Groups mapped for VDE 0160 / EN 50178 Clearance Requirements on Printed Circuit Boards
- Reconcile requirements of each compliance Table (3.4, 3.5, 3.6) for product compliance to the VDE 0160 / EN50178 safety standard.

Table 3.6 VDE 0160 / EN 50178 Test Voltage Compliance
Avago Optoisolator Product Groups*
Safety Requirements for Electrical Equipment for use in Electrical Power Installations

Rated Insulation Voltage V rms	Basic Insulation	Reinforced Insulation
230	A, B, C, D, E, F, G	A, B, C, D, E, F, G
300	A, B, C, D, E, F, G	A, B, C, D, E, F, G
400	A, B, C, D, E, F, G	A, B, C**
600		A, B, C**
690	A, B, C, D, E, F, G	A, C**
1000	A, B, C, D, E, F, G	A, C*

* NOTES:

- See Table 2.1 for Avago Optoisolator Product Groups:
 Group A = 400 mil Widebody Package (H/ACNW/HCNR),
 Group B = 300 mil DIP Package (HCPL-7XXX/JXXX) and SO-16 package (HCPL-XXXJ),
 Group C = 300 mil DIP Package (HCPL-XXXX),
 Group D = SO-8
 - Material Group IIIa.
 - Avago Optoisolators mapped per VDE0160 / EN 50178 Test Voltage and compliance is based on UL ratings.
 - Reconcile requirements for each compliance Table (3.4,3.5, 3.6) for product compliance to the VDE 0160 / EN 50178 safety standard.
- ** 5.Group C here includes only option 020 (5000 V rms / 1 min, UL) parts. Package.
 Group E = SO-5 Package. Group F & G = Stretch SO Packages.

3.3 Avago Optoisolator Compliance Summary for IEC 60065

Reconciliation of the IEC 60065 requirements for Creepage, Clearance, and Test voltages, as shown in Tables (3.7, 3.8) indicates that Avago Technologies Optoisolator product groups will comply with the standards requirements under the following cases. Only a few cases are considered as examples, and the reader can readily interpret other cases by considering the compliance shown in the Tables (3.7, 3.8):

a) For installation category II, Avago Optoisolator product groups [A, B, C (option 020)] will comply with the IEC 60065 requirements at mains supply voltage of 1200 V peak or lower at the reinforced insulation level. Only group (A) will meet the mains supply voltage requirements at 1500 V peak under similar conditions.

- b) For installation category I, Avago Optoisolator product groups (A, B, C, D) will comply with the IEC 60065 requirements at a mains supply voltage of 500V peak or lower at basic insulation level.
- c) For installation category I or II, Avago Optoisolator product groups (A, B, C, D) will comply with the IEC 60065 requirements at a mains supply voltage of 70 V peak or lower at either basic or reinforced insulation level.

**Table 3.7 IEC 60065 Creepage / Clearance Compliance
Avago Optoisolator Product Groups*
Safety Requirements for mains operated electronic and related apparatus for household and similar general use**

Supply Mains Voltage V peak	Insulation	Avago Optoisolator Product Group*
< 70	Basic	A, B, C, D, E, F, G
	Reinforced	A, B, C, D, E, F, G
354	Basic	A, B, C, D, E, F, G
	Reinforced	A, B, C, F, G
500	Basic	A, B, C, D, E, F, G
	Reinforced	A, B, C, F, G
900	Basic	A, B, C, F, G
	Reinforced	A, B, C, F, G
1200	Basic	A, B, C, F, G
	Reinforced	A, B, C, F, G
1500	Basic	A
	Reinforced	A

* NOTES:

1. See Table 2.1 for Avago Optoisolator Product Groups:
 Group A = 400 mil Widebody Package (H/ACNW/HCNR),
 Group B = 300 mil DIP Package (HCPL-7XXX/JXXX) and SO-16 package (HCPL-XXXJ),
 Group C = 300 mil DIP Package (HCPL-XXXX),
 Group D = SO-8 Package.
 Group E = SO-5 Package.
 Group F & G = Stretch SO Packages.
2. Class 1 equipment uses Basic Insulation, Class II equipment uses Reinforced Insulation.
3. Reconcile requirements of each compliance Table (3.7 and 3.8) for product compliance to the IEC 60065 safety standard.

**Table 3.8 IEC 60065 Test Voltage Compliance
Avago Optoisolator Product Groups*
Safety Requirements for mains operated electronic and related apparatus for household and similar general use**

Supply Mains Voltage V peak	Insulation	Avago Optoisolator Product Group*
< 70	Basic	A, B, C, D, E, F, G
	Reinforced	A, B, C, D, E, F, G
354	Basic	A, B, C, D, E, F, G
	Reinforced	A, B, C**
500	Basic	A, B, C, D, E, F, G
	Reinforced	A, B, C**
900	Basic	A, B, C, D, E, F, G
	Reinforced	A, B, C, F, G**
1200	Basic	A, B, C, F, G**
	Reinforced	A, B, C, F, G**
1500	Basic	A, B, C, F, G**
	Reinforced	A, B, C, F, G**

* NOTES:

- See Table 2.1 for Avago Optoisolator Product Groups:
Group A = 400 mil Widebody Package (H/ACNW/HCNR),
Group B = 300 mil DIP Package (HCPL-7XXX/JXXX) and SO-16 package (HCPL-XXXJ),
Group C = 300 mil DIP Package (HCPL-XXXX),
Group D = SO-8 Package.
- Class 1 equipment uses Basic Insulation, Class II equipment uses Reinforced Insulation.
- Reconcile requirements of each compliance Table (3.7 and 3.8) for product compliance to the IEC 60065 safety standard.
- **4. Group C here includes only option 020 (5000 V rms / 1 min, UL) parts.

3.4 Avago Optoisolator Compliance Summary for IEC 60601-1

Reconciliation of the IEC 60601-1 requirements for Creepage, Clearance, and Test voltages, as shown in Tables (3.9, 3.10) indicates that Avago Technologies Optoisolator product groups will comply with the standards requirements under the following cases. Only a few cases are considered as examples, and the reader can readily interpret other cases by considering the compliance shown in the Tables (3.9, 3.10):

- For installation category II (class II equipment), Avago Optoisolator product groups [A, B, C (option 020)] will comply with the IEC 60601-1 requirements at reference voltage of 150 V dc / 125 V ac or lower at the reinforced insulation level. Only group (A) will meet the reference voltage requirements at 300 V dc / 250 V ac under similar conditions (reinforced insulation level).
- For installation category I (class I equipment), Avago Optoisolator product groups (A, B, C, D) will comply with the IEC 60601-1 requirements at a reference voltage of 300 V dc / 250 V ac or lower at basic insulation level. Only groups (A, B) will meet the reference voltage requirements at 600 V dc / 500 V ac or lower under similar conditions (basic insulation level).
- For installation category I (class I equipment), Avago Optoisolator product groups (A, B, C) will comply with the IEC 60601-1 requirements at a reference voltage of 450V dc / 380V ac or lower at basic insulation level.

**Table 3.9 IEC 60601-1 Creepage / Clearance Compliance
Avago Optoisolator Product Groups*
General Safety Requirements for Medical Electrical Equipment**

Reference* Voltage dc	Reference* Voltage ac	Installation Level	Avago Optoisolator Groups*
15	12	Basic	A, B, C, D, E, F, G
		Reinforced	A, B, C, D, E, F, G
34	30	Basic	A, B, C, D, E, F, G
		Reinforced	A, B, C, D, E, F, G
75	60	Basic	A, B, C, D, E, F, G
		Reinforced	A, B, C, D, E, F, G
150	125	Basic	A, B, C, D, E, F, G
		Reinforced	A, B, C
300	250	Basic	A, B, C, D, E, F, G
		Reinforced	A, B
450	380	Basic	A, B, C, F, G
		Reinforced	
600	500	Basic	A, B
		Reinforced	

* NOTES:

- See Table 2.1 for Avago Optoisolator Product Groups:
Group A = 400 mil Widebody Package (H/ACNW/HCNR),
Group B = 300 mil DIP Package (HCPL-7XXX/JXXX) and SO-16 package (HCPL-XXXJ),
Group C = 300 mil DIP Package (HCPL-XXXX),
Group D = SO-8 Package.
- Avago Optoisolator Products mapped for IEC 60601-1 Creepage/Clearance values
- Reconcile requirements of each compliance Table (3.9 and 3.10) for product compliance to the IEC 60601-1 safety standard.
- Reference voltage is the voltage which the relevant insulation is subjected in NORMAL USE and RATED supply voltage, whichever is greater.
- Class I equipment uses Basic Insulation, Class II equipment uses Reinforced Insulations.

**Table 3.10 IEC 60601-1 Test Voltage Compliance
Avago Optoisolator Product Groups*
General Safety Requirements for Medical Electrical Equipment**

Reference* Voltage dc	Reference* Voltage ac	Installation Level	Avago Optoisolator Groups*
15	12	Basic	A, B, C, D, E, F, G
		Reinforced	A, B, C, D, E, F, G
34	30	Basic	A, B, C, D, E, F, G
		Reinforced	A, B, C, D, E, F, G
75	60	Basic	A, B, C, D, E, F, G
		Reinforced	A, B, C**
150	125	Basic	A, B, C, D, E, F, G
		Reinforced	A, B, C**
300	250	Basic	A, B, C, D, E, F, G
		Reinforced	A, C**
450	380	Basic	A, B, C, D, E, F, G
		Reinforced	A, C**
600	500	Basic	A, B, C, D, E, F, G
		Reinforced	

* NOTES:

- See Table 2.1 for Avago Optoisolator Product Groups:
Group A = 400 mil Widebody Package (H/ACNW/HCNR),
Group B = 300 mil DIP Package (HCPL-7XXX/JXXX) and SO-16 package (HCPL-XXXJ),
Group C = 300 mil DIP Package (HCPL-XXXX),
Group D = SO-8 Package.
Group E = SO-5 Package HCPL-MXXX).
Group F & G = Stretch SO Package (ACPL-H/P/K/WXXX).
- Avago Optoisolator Products mapped for IEC 60601-1 Creepage/Clearance values.
- Reconcile requirements of each compliance Table (3.9 and 3.10) for product compliance to the IEC 60601-1 safety standard.
- Reference voltage is the voltage which the relevant insulation is subjected in NORMAL USE and RATED supply voltage, whichever is greater.
- Class I equipment uses Basic Insulation, Class II equipment uses Reinforced Insulations.
- Avago Optoisolators mapped per IEC 60601-1 Test Voltage and compliance is based on UL ratings.
- Group C here includes only option 020 (5000 Vrms/1 min, UL) parts.

3.5 Avago Optoisolator Compliance Summary for IEC 60664

IEC 60664 is not a stand alone equipment level safety standard, but is an insulation coordination safety standard. Various equipment manufacturers may refer either in part or in whole to the requirements of this standard.

Reconciliation of the IEC 60664 requirements for Creepage, Clearance, and Test voltages, as shown in Tables (3.11, 3.12, 3.13, 3.14) indicates that Avago Technologies Optoisolator product groups will comply with the standards requirements under the following cases. Only, a few cases are considered as examples, and the reader can readily interpret other cases by considering the compliance shown in the Tables (3.11, 3.12, 3.13, 3.14):

a) For installation category II and pollution degree 2 environment, Avago Optoisolator product group (A) will comply with the IEC 60664 requirements at a working voltage of 500 V rms or lower at the reinforced insulation level.

- b) For installation category II and pollution degree 2 environment, Avago Optoisolator product groups (A, B, C) will comply with the IEC 60664 requirements at a working voltage of 250 V rms or lower at the reinforced insulation level. Groups (A, B, C, D) will meet the working voltage requirements at 200 V rms or lower under similar conditions.
- c) For installation category II and pollution degree 2 environment Avago Optoisolator product groups (A) will comply with the IEC 60664 requirements at a working voltage of 1000 V rms or lower at basic insulation level. Groups (A, B) will comply with similar requirements at a working voltage of 800 V rms or lower, and groups (A, B, C) will comply at a working voltage of 500 V rms or lower at the basic insulation level.

**Table 3.11 IEC 60664 Clearance Compliance
Avago Optoisolator Product Groups*
Insulation Coordination for Equipment within Low Voltage Systems**

Required Impulse Withstand Voltage (kV)	Avago Product Groups* Impulse Basic Insulation (Inhomogenous Electric Fields)		
	Pollution Degrees		
	1	2	3
< 1	A, B, C, D, E, F, G	A, B, C, D, E, F, G	A, B, C, D, E, F, G
1.2	A, B, C, D, E, F, G	A, B, C, D, E, F, G	A, B, C, D, E, F, G
1.5	A, B, C, D, E, F, G	A, B, C, D, E, F, G	A, B, C, D, E, F, G
2	A, B, C, D, E, F, G	A, B, C, D, E, F, G	A, B, C, D, E, F, G
2.5	A, B, C, D, E, F, G	A, B, C, D, E, F, G	A, B, C, D, E, F, G
3	A, B, C, D, E, F, G	A, B, C, D, E, F, G	A, B, C, D, E, F, G
4	A, B, C, F, G	A, B, C, F, G	A, B, C, F, G
5	A, G	A, G	A, G
6	A, G	A, G	A, G
8	A	A	A

* NOTES:

- See Table 2.1 for Avago Optoisolator Product Groups:
Group A = 400 mil Widebody Package (HCNW/HCNR),
Group B = 300 mil DIP Package (HCPL-7XXX/JXXX) and SO-16 package (HCPL-XXXJ),
Group C = 300 mil DIP Package (HCPL-XXXX),
Group D = SO-8 Package.
Group E = SO-5 Package.
Group F & G = Stretch SO Packages.
- Avago Optoisolator Products mapped for IEC 60664-1 Clearance values
- Reconcile requirements of each compliance Table (3.11, 3.12, 3.13, 3.14) for product compliance to the IEC 60664-1 safety standard.

**Table 3.12 IEC 60664-1 Creepage Compliance
Avago Optoisolator Product Groups*
Insulation Coordination for Equipment within Low-Voltage Systems**

Working Voltage V rms	Insulation Level	Avago Product Groups*	
		Pollution Degree 2 Material Group III	Pollution Degree 3 Material Group III*
100	Basic	A, B, C, D, E, F, G	A, B, C, D, E, F, G
	Reinforced	A, B, C, D, E, F, G	A, B, C, D, E, F, G
125	Basic	A, B, C, D, E, F, G	A, B, C, D, E, F, G
	Reinforced	A, B, C, D, E, F, G	A, B, C, D, E, F, G
160	Basic	A, B, C, D, E, F, G	A, B, C, D, E, F, G
	Reinforced	A, B, C, D, E, F, G	A, B, C
200	Basic	A, B, C, D, E, F, G	A, B, C, D, E, F, G
	Reinforced	A, B, C, D, E, F, G	A, B, C
250	Basic	A, B, C, D, E, F, G	A, B, C, D, E, F, G
	Reinforced	A, B, C	A, B
320	Basic	A, B, C, D, E, F, G	A, B, C
	Reinforced	A, B, C	A
400	Basic	A, B, C, D, E, F, G	A, B, C
	Reinforced	A, B	
500	Basic	A, B, C	A, B
	Reinforced	A	
630	Basic	A, B, C	A
	Reinforced		
800	Basic	A, B	
	Reinforced		
1000	Basic	A	
	Reinforced		

* NOTES:

- See Table 2.1 for Avago Optoisolator Product Groups:
Group A = 400 mil Widebody Package (H/ACNW/HCNR),
Group B = 300 mil DIP Package (HCPL-7XXX/JXXX) and SO-16 package (HCPL-XXXJ),
Group C = 300 mil DIP Package (HCPL-XXXX),
Group D = SO-8 Package.
Group E = SO-5 Package.
Group F & G = Stretch SO Packages.
- Avago Optoisolator Products mapped for IEC 60664-1 Clearance values
- Reconcile requirements of each compliance Table (3.11, 3.12, 3.13, 3.14) for product compliance to the IEC 60664-1 safety standard.

**Table 3.13 IEC 60664-1 Rated Impulse Voltage Compliance For Clearances
Avago Optoisolator Product Groups**
Insulation Coordination for Equipment within Low-Voltage Systems**

Nominal Voltage of the Supply System (V)		Voltage Line to Neutral a.c. or d.c (V)	Avago Optoisolator Product Groups* V Overvoltage Category			
Three Phase	Single Phase		I	II	III	IV
		50	A, B, C, D, E, F, G	A, B, C, D, E, F, G	A, B, C, D, E, F, G	A, B, C, D, E, F, G
		100	A, B, C, D, E, F, G	A, B, C, D, E, F, G	A, B, C, D, E, F, G	A, B, C, D, E, F, G
	120-540	150	A, B, C, D, E, F, G	A, B, C, D, E, F, G	A, B, C, D, E, F, G	A, B, C, D, E, F, G
230/400* 277/480*		300	A, B, C, D, E, F, G	A, B, C, D, E, F, G	A, B, C, D, E, F, G	A, B, C
400/690		600	A, B, C, D, E, F, G	A, B, C, D, E, F, G	A, B, C	A
1000		1000	A, B, C, D, E, F, G	A, B, C	A	

* NOTES:

- See Table 2.1 for Avago Optoisolator Product Groups:
Group A = 400 mil Widebody Package (H/ACNW/HCLR),
Group B = 300 mil DIP Package (HCPL-7XXX/JXXX) and SO-16 package (HCPL-XXXJ),
Group C = 300 mil DIP Package (HCPL-XXXX),
Group D = SO-8 Package.
Group E = SO-5 Package.
Group F & G = Stretch SO Packages.
- Avago Optoisolator Products mapped for IEC 60664-1 Test Voltages for Clearance values, and this compliance is applicable for VDE 0884 approved parts only.
- Reconcile requirements of each compliance Table (3.11, 3.12, 3.13, 3.14) for product compliance to the IEC 60664-1 safety standard.
- The / mark indicates a four-wire threephase distribution system. The lower value is the voltage line to neutral, while the higher value is the voltage line-to-line. Where only one value is indicated, it refers to three wire, three phase systems and specifies the value line-to-line

3.6 Avago Optoisolator Compliance Summary for IEC 60950

Reconciliation of the IEC 60950 requirements for Creepage, Clearance, Distance through Insulation, and Test voltages, as shown in Tables (3.15, 3.16, 3.17, 3.18, 3.19) indicates that Avago Technologies Optoisolator product groups will comply with the standards requirements under the following cases. Only a few cases are considered as examples, and the reader can readily interpret other cases by considering the compliance shown in the Tables (3.15, 3.16, 3.17, 3.18, 3.19):

- For installation category II and pollution degree 2 environment, Avago Optoisolator product group (A, B) will comply with the IEC 60950 requirements at a working voltage of 400 V rms or lower at the reinforced insulation level.
- For installation category II and pollution degree 2 environment, Avago Optoisolator product groups (A, B, C) will comply with the IEC 60950 requirements at a working voltage of 600 V rms or lower at the basic insulation level. Groups (A, B, C, D, E, F, G) will meet the working voltage requirements at 400 V rms or lower under similar conditions at the basic insulation level.
- For installation category II and pollution degree 2 environment Avago Optoisolator product groups (A) will comply with the IEC 60950 requirements at a working voltage of 1000 V rms or lower at basic insulation level.

**Table 3.14 IEC 60950 Clearance Compliance
Avago Optoisolator Product Groups*
Safety of Information Technology Equipment, including Electrical Business Equipment**

Working Voltage		Insulation Level	Avago Optoisolator Product Groups* Installation Category I and 2, Pollution Degree 1 and 2		
V peak or V d c	V rms		Nominal Mains Supply < 150V Transient Rating 1500V	Nominal Mains Supply < 300V Transient Rating 2500V	Nominal Mains 300V <Supply< 600V Transient Rating 4000V
70	50	Basic	A, B, C, D, E, F, G	A, B, C, D, E, F, G	A, B, C, D, E, F, G
		Reinforced	A, B, C, D, E, F, G	A, B, C, D, E, F, G	A, B, C, D, E, F, G
210	150	Basic	A, B, C, D, E, F, G	A, B, C, D, E, F, G	A, B, C, D, E, F, G
		Reinforced	A, B**	A, B**	A, B**
420	300	Basic	A, B, C, D, E, F, G	A, B, C, D, E, F, G	A, B, C, D, E, F, G
		Reinforced	A, B**	A, B**	A, B**
891	400	Basic	A, B, C, D, E, F, G	A, B, C, D, E, F, G	A, B, C, D, E, F, G
		Reinforced	A, B**	A, B**	A, B**
840	600	Basic	A, B, C	A, B, C	A, B, C
		Reinforced			
1400	1000	Basic	A	A	A
		Reinforced			

* NOTES:

- See Table 2.1 for Avago Optoisolator Product Groups:
Group A = 400 mil Widebody Package (H/ACNW/H CNR),
Group B = 300 mil DIP Package (HCPL-7XXX/JXXX) and SO-16 package (HCPL-XXXJ),
Group C = 300 mil DIP Package (HCPL-XXXX),
Group D = SO-8 Package.
Group E = SO-5 Package.
Group F & G = Stretch SO Packages.
- Reconcile requirements of each compliance Table (3.15, 3.16, 3.17, 3.18, 3.19) for product compliance to the IEC 60950 safety standard.
- IEC 60950 distance through Insulation requirement precludes groups C and D to be used at working voltage above 50 Vrms, there is no through insulation thickness requirement at or below 50 Vrms working voltage. This applies at the reinforced insulation level only.
- Creepage requirements preclude using any optoisolator group at the reinforced insulation level at a working Voltage of 1000 Vrms and 600 Vrms.

**Table 3.15 IEC 60950 Clearance Compliance
Avago Optoisolator Product Groups*
Safety of Information Technology Equipment, including Electrical Business Equipment**

Working Voltage		Insulation Level	Avago Optoisolator Product Groups* Installation Category I and 2, Pollution Degree 3		
V peak or V d c	V rms		Nominal Mains Supply < 150V Transient Rating 1500V	Nominal Mains Supply < 300V Transient Rating 2500V	Nominal Mains 300V <Supply< 600V Transient Rating 4000V
70	50	Basic	A, B, C, D, E, F, G	A, B, C, D, E, F, G	A, B, C, D, E, F, G
		Reinforced	A, B, C, D, E, F, G	A, B, C, D, E, F, G	A, B, C, D, E, F, G
210	150	Basic	A, B, C, D, E, F, G	A, B, C, D, E, F, G	A, B, C, D, E, F, G
		Reinforced	A, B**	A, B**	A, B**
420	300	Basic	A, B, C, D, E, F, G	A, B, C, D, E, F, G	A, B, C, D, E, F, G
		Reinforced	A**	A**	A**
891	400	Basic	A, B, C, F, G	A, B, C, F, G	A, B, C, F, G
		Reinforced			
840	600	Basic	A	A	A
		Reinforced			
1400	1000	Basic			
		Reinforced			

* NOTES:

- See Table 2.1 for Avago Optoisolator Product Groups:
Group A = 400 mil Widebody Package (H/ACNW/H CNR),
Group B = 300 mil DIP Package (HCPL-7XXX/JXXX) and SO-16 package (HCPL-XXXJ),
Group C = 300 mil DIP Package (HCPL-XXXX),
Group D = SO-8 Package.
Group E = SO-5 Package.
Group F & G = Stretch SO Packages.
- Reconcile requirements of each compliance Table (3.15, 3.16, 3.17, 3.18, 3.19) for product compliance to the IEC 950 safety standard.
- IEC 950 distance through Insulation requirement precludes groups C and D to be used at working voltage above 50 Vrms, there is no through insulation thickness requirement at or below 50 Vrms working voltage. This applies at the reinforced insulation level only.
- Creepage requirements preclude using any optoisolator group at the reinforced insulation level at a working Voltage of 1000 Vrms, 600 Vrms, or 400 V rms.

**Table 3.16 IEC 60950 Creepage Compliance
Avago Optoisolator Product Groups*
Safety of Information Technology Equipment, including Electrical Business Equipment**

Working Voltage up to and Including Vrms or V d.c.	Insulation Level	Avago Optocoupler Product Groups*	
		Pollution Degree 2 Material Group IIIa	Pollution Degree 3 Material Group IIIa
50	Basic	A, B, C, D, E, F, G	A, B, C, D, E, F, G
	Reinforced	A, B, C, D, E, F, G	A, B, C, D, E, F, G
150	Basic	A, B, C, D, E, F, G	A, B, C, D, E, F, G
	Reinforced	A, B**	A, B**
300	Basic	A, B, C, D, E, F, G	A, B, C, F, G
	Reinforced	A, B**	A**
400	Basic	A, B, C, D, E, F, G	A, B, C, F, G
	Reinforced	A, B**	
600	Basic	A, B, C, F, G	A
	Reinforced		
1000	Basic	A	
	Reinforced		

* NOTES:

- See Table 2.1 for Avago Optoisolator Product Groups:
Group A = 400 mil Widebody Package (H/ACNW/H CNR),
Group B = 300 mil DIP Package (HCPL-7XXX/JXXX) and SO-16 package (HCPL-XXXJ),
Group C = 300 mil DIP Package (HCPL-XXXX),
Group D = SO-8 Package.
Group E = SO-5 Package.
Groups F & G = Stretch SO Packages.
- Reconcile requirements of each compliance Table (3.15, 3.16, 3.17, 3.18, 3.19) for product compliance to the IEC 60950 safety standard.
- IEC 60950 distance through Insulation requirement precludes groups C and D to be used at working voltage above 50 Vrms, there is no through insulation thickness requirement at or below 50 Vrms working voltage. This applies at the reinforced insulation level only.

**Table 3.17 IEC 60950 Distance Through Insulation Compliance
Avago Optoisolator Product Groups*
Safety of Information Technology Equipment, including Electrical Business Equipment**

Working Voltage up to and Including Vrms or V d.c.	Insulation Level	Avago Optocoupler Product Groups*
50	Basic	A, B, C, D, E, F, G
	Reinforced	A, B, C, D, E, F, G**
150	Basic	A, B, C, D, E, F, G
	Reinforced	A, B**
300	Basic	A, B, C, D, E, F, G
	Reinforced	A, B**
400	Basic	A, B, C, D, E, F, G
	Reinforced	A, B**
600	Basic	A, B, C**
	Reinforced	
1000	Basic	A***
	Reinforced	

* NOTES:

- See Table 2.1 for Avago Optoisolator Product Groups:
Group A = 400 mil Widebody Package (H/ACNW/H CNR),
Group B = 300 mil DIP Package (HCPL-7XXX/JXXX) and SO-16 package (HCPL-XXXJ),
Group C = 300 mil DIP Package (HCPL-XXXX),
Group D = SO-8 Package.
Group E = SO-5 Package.
Groups F & G = Stretch SO Packages.
- Reconcile requirements of each compliance Table (3.15, 3.16, 3.17, 3.18, 3.19) for product compliance to the IEC 60950 safety standard.
- IEC 60950 distance through Insulation requirement precludes groups C and D to be used at working voltage above 50 Vrms, there is no through insulation thickness requirement at or below 50 Vrms working voltage. This applies at the reinforced insulation level only.
- Creepage requirements will preclude the groups not shown (pollution degree 2).

**Table 3.18 IEC 60950 Test Voltage Compliance
Avago Optoisolator Product Groups*
Safety of Information Technology Equipment, including Electrical Business Equipment**

Working Voltage up to and Including Vrms or V d.c.	Insulation Level	Avago Optocoupler Product Groups*
50	Basic	A, B, C, D, E, F, G
	Reinforced	A, B, C, D, E, F, G**
150	Basic	A, B, C, D, E, F, G
	Reinforced	A, B**
300	Basic	A, B, C, D, E, F, G
	Reinforced	A, B**
400	Basic	A, B, C, D, E, F, G
	Reinforced	A, B**
600	Basic	A, B, C, F, G
	Reinforced	
1000	Basic	A
	Reinforced	

* NOTES:

- See Table 2.1 for Avago Optoisolator Product Groups:
Group A = 400 mil Widebody Package (HCNW/HCNR),
Group B = 300 mil DIP Package (HCPL-7XXX/JXXX) and SO-16 package (HCPL-XXXJ),
Group C = 300 mil DIP Package (HCPL-XXXX),
Group D = SO-8 Package.
Group E = SO-5 Package.
Groups F & G = Stretch SO Packages.
- Reconcile requirements of each compliance Table (3.15, 3.16, 3.17, 3.18, 3.19) for product compliance to the IEC 60950 safety standard.
- IEC 60950 distance through Insulation requirement precludes groups C and D to be used at working voltage above 50 Vrms, there is no through insulation thickness requirement below 50 V rms working voltage. This applies at the reinforced insulation level only.
- Test Voltage compliance is based on UL ratings (V rms / 1 min) test.

3.7 Avago Optoisolator Compliance Summary for UL 508

Reconciliation of the UL 508 requirements for Creepage, Clearance and Test voltages, as shown in Tables (3.20, 3.21, 3.22, 3.23, 3.24) indicates that Avago Technologies Optoisolator product groups will comply with the standards requirements under the following cases. Only a few cases are considered as examples, and the reader can readily interpret other cases by considering the compliance shown in the Tables (3.20, 3.21, 3.22, 3.23, 3.24):

- For products with known and controlled transient voltages, and having short circuit power less than or equal to 500 VA, Avago Optoisolator product groups (A, B, C, D, E, F, G) will meet the requirements of the UL 508 standard at a working voltage of 900 V peak or lower.
- For products with known and controlled transient voltages, and having short circuit power greater than 500 VA but not more than 10 kVA, Avago Optoisolator product groups (A, B, C) will meet the requirements of the UL 508 standard at a working voltage of 900 V peak or lower. Under similar conditions, Groups (A, B, C, D, E, F, G) will meet the UL requirements if the working voltage is 450 V peak or lower.
- For products with known and controlled transient voltages, and having short circuit power greater than 10 kVA, Avago Optoisolator product groups (A, B, C) will meet the requirements of the UL 508 standard at a working voltage of 450 V peak or lower. Under similar conditions, Groups (A, B, C, D, E, F, G) will meet the UL requirements if the working voltage is 225V peak or lower.

**Table 3.19 UL 508 Creepage Compliance Between Traces of Opposite Polarity on Printed Wiring Boards
Avago Optoisolator Product Groups*
Safety Requirements for Industrial Control Equipment**

Volts* Vrms or dc	Transient Voltages *Not Limited		Transient Voltages Limited***	
	Coated****	UnCoated	Coated****	UnCoated
	Avago Optoisolator Product Groups*			
320	A, B, C, D, E, F, G	A, B, C, D, E, F, G	A, B, C, D, E, F, G	A, B, C, D, E, F, G
400	A, B, C, D, E, F, G	A, B, C, D, E, F, G	A, B, C, D, E, F, G	A, B, C, D, E, F, G
500	A, B, C, D, E, F, G	A, B, C, D, E, F, G	A, B, C, D, E, F, G	A, B, C, D, E, F, G
630	A, B, C, D, E, F, G	A, B, C, D, E, F, G	A, B, C, D, E, F, G	A, B, C, D, E, F, G
800	A, B, C, D, E, F, G	A, B, C	A, B, C, D, E, F, G	A, B, C, D, E, F, G
1000	A, B, C, D, E, F, G	A, B, C	A, B, C, D, E, F, G	A, B, C

* NOTES:

- See Table 2.1 for Avago Optoisolator Product Groups:
Group A = 400 mil Widebody Package (H/ACNW/H CNR),
Group B = 300 mil DIP Package (HCPL-7XXX/JXXX) and SO-16 package (HCPL-XXXJ),
Group C = 300 mil DIP Package (HCPL-XXXX),
Group D = SO-8 Package.
Group E = SO-5 Package.
Groups F & G = Stretch SO Packages.
 - Reconcile requirements of each compliance Table (3.20, 3.21, 3.22, 3.23, 3.24) for product compliance to the UL 508 safety standard.
- ***3. Voltage between the traces where spacing is measured
- ***4. The maximum recurring peak voltages shall not exceed the applicable value specified in Table 6.3 of UL 840 (see Table 4.7.2).
- ***5. The coating shall comply with the requirements of the Printed Wiring Board Coating Performance test, Section 12, in UL 840, or another equivalent method.

Table 3.20 UL 508 Creepage and Clearance Compliance for Products with Known and Controlled Transient Voltages *
 Avago Optoisolator Product Groups*
 Safety Requirements for Industrial Control Equipment**

Short Circuit Power**	Peak Working Voltage	Avago Optoisolator Product Groups * Between any uninsulated live part and an uninsulated live part of opposite polarity, uninsulated grounded part other than enclosure, or exposed metal part.	
		Through air (Clearance)	Over Surface (Creepage)
More than 10 kVA, for use where transient voltages are known and controlled	0 – 50	A, B, C, D, E, F, G	A, B, C, D, E, F, G
	51 – 225	A, B, C, D, E, F, G	A, B, C, D, E, F, G
	226 – 450	A, B, C, D, E, F, G	A, B, C
	451 – 900	A, B	
More than 500 VA, but not more than 10 kVA	0 – 50	A, B, C, D, E, F, G	A, B, C, D, E, F, G
	51 – 225	A, B, C, D, E, F, G	A, B, C, D, E, F, G
	226 – 450	A, B, C, D, E, F, G	A, B, C, D, E, F, G
	451 – 900	A, B, C	A, B, C
500 VA or less	0 – 36	A, B, C, D, E, F, G	A, B, C, D, E, F, G
	37 – 72	A, B, C, D, E, F, G	A, B, C, D, E, F, G
	73 – 100	A, B, C, D, E, F, G	A, B, C, D, E, F, G
	101 – 225	A, B, C, D, E, F, G	A, B, C, D, E, F, G
	226 – 450	A, B, C, D, E, F, G	A, B, C, D, E, F, G
	451 – 900	A, B, C, D, E, F, G	A, B, C, D, E, F, G

* NOTES:

1. See Table 2.1 for Avago Optoisolator Product Groups:
 Group A = 400 mil Widebody Package (H/ACNW/HENR),
 Group B = 300 mil DIP Package (HCPL-7XXX/JXXX) and SO-16 package (HCPL-XXXJ),
 Group C = 300 mil DIP Package (HCPL-XXXX),
 Group D = SO-8 Package.
 Group E = SO-5 Package.
 Group F & G = Stretch SO Packages.
2. Reconcile requirements of each compliance Table (3.20, 3.21, 3.22, 3.23, 3.24) for product compliance to the UL 508 safety standard.
- **3. Maximum short-circuit power is the product of the open-circuit voltage and the short circuit current available at the supply terminals when protective devices are bypassed.
- ***4. The spacings in industrial control equipment in which transient voltages are known and controlled by a transient suppressive device shall not be less than those specified in Table 4.7.4 except that spacings at a field-wiring terminal shall be in accordance with Table 4.7.3. (the transient suppressive devices shall prevent peak transient voltages from exceeding 300 percent of the instantaneous peak working voltage or 300V, whichever is greater).

**Table 3.21 UL 508 Creepage and Clearance Compliance Avago Optoisolator Product Groups*
Safety Requirements for Industrial Control Equipment**

Potential Involved in V rms or dc		Avago Optoisolator Product Groups *							
		A General Industrial Control Equipment			B Devices having Limited Ratings**		C Other Devices***		D All Circuits ****
		50-150	151-300	301-600	50-300	301-600	51-1501	51-300	0-50
Between any uninsulated live part and an uninsulated live part of opposite polarity, uninsulated grounded part other than the enclosure, or exposed metal part	Through air or oil (Clearance)	A, B, C, D, E, F, G	A, B, C	A	A, B, C, D, E, F, G	A, B, C, D, E, F, G	A, B, C, D, E, F, G	A, B, C	A, B, C, D, E, F, G
	Over Surface (Creepage)	A, B, C	A		A, B, C, D, E, F, G	A	A, B, C	A, B, C	A, B, C, D, E, F, G

* NOTES:

- See Table 2.1 for Avago Optoisolator Product Groups:
Group A = 400 mil Widebody Package (H/ACNW/HCNR),
Group B = 300 mil DIP Package (HCPL-7XXX/JXXX) and SO-16 package (HCPL-XXXJ),
Group C = 300 mil DIP Package (HCPL-XXXX),
Group D = SO-8 Package.
Group E = SO-5 Package.
Groups F & G = Stretch SO Packages.
- Reconcile requirements of each compliance Table (3.20, 3.21, 3.22, 3.23, 3.24) for product compliance to the UL 508 safety standard.
- The spacings specified in column B of Table 4.7.3 are applicable to equipment:
 - Rated 1 horsepower (746 W output) or equivalent FLA, or less, 720 Vampères break pilot duty or less; or not more than 15 amperes at 51 - 150 volts, 10 amperes at 151 - 300 volts, or 5 amperes at 301 - 600 V.
 - Of the type described in (1) which controls more than one load provided the total load connected to the line at one time does not exceed 2 horsepower (1492 W output), 1440 volt-amperes, or have a current rating greater than 30 amperes at 51 - 150 volts, 20 amperes at 151 - 300 volts, or 10 amperes at 301 - 600 volts
- The spacings specified in column C of table 4.7.3 apply only to equipment rated at 300 volts or less, and 1 horsepower (746 W output) or less or 2000 volt-amperes or less per pole and to a device that has a current rating per pole of 15 amperes or less at 51 -150 volts, 10 amperes at 301 -600 volts, or both.
- Spacings apply as indicated, except as specified in (4) and the spacings between the low potential circuit are in accordance with the requirements that are applicable to the high-potential circuit. See Table 4.7.3.
- The primary circuit spacings in industrial control power supplies intended for use in a pollution degree 2 environment shall be at at least those specified in tables 4.7.5 and 4.7.6. See section 34 in UL 508. Spacings at field wiring terminal are per this table.

**Table 3.22 UL 508 Creepage and Clearance Compliance Power Supply Primary
Circuit Spacings Other than at Field-Wiring Terminals
Avago Optoisolator Product Groups*
Safety Requirements for Industrial Control Devices**

Potential Involved in Volts V rms		Avago Optoisolator Groups *	
		Over Surface (Creepage)	Through air (Clearance)
0 – 50	0 – 70.7	A, B, C, D, E, F, G	A, B, C, D, E, F, G
51 – 125	72.1 – 176.8	A, B, C, D, E, F, G	A, B, C, D, E, F, G
126 – 250	178.2 – 353.6	A, B, C, D, E, F, G	A, B, C, D, E, F, G
251 – 600	355.0 – 848.5		A

**Table 3.23 UL 508 Creepage and Clearance Compliance Power Supply
Primary-Circuit Spacings at Field-Wiring Terminals
Avago Optoisolator Product Groups*
Safety Requirements for Industrial Control Devices**

Potential Involved in Volts Vrms	Avago Optoisolator Groups *		
	Between Field Wiring Terminals	Between Field-Wiring Terminals and other Uninsulated parts Not always of the Same polarity	
	Through air or Over Surface (Creepage or Clearance)	Over Surface (Creepage)	Through air (Clearance)
0 – 50	A, B, C, D, E, F, G	A, B, C, D, E, F, G	A, B, C, D, E, F, G
51 – 250	A, B, C	A, B, C	A, B, C
251 – 600			A

* NOTES:

- See Table 2.1 for Avago Optoisolator Product Groups:
Group A = 400 mil Widebody Package (H/ACNW/HCNR),
Group B = 300 mil DIP Package (HCPL-7XXX/JXXX) and SO-16 package (HCPL-XXXJ),
Group C = 300 mil DIP Package (HCPL-XXXX),
Group D = SO-8 Package.
Group E = SO-5 Package.
Groups F & G = Stretch SO Packages.
- Reconcile requirements of each compliance Table (3.20, 3.21, 3.22, 3.23, 3.24) for product compliance to the UL 508 safety standard.

3.8 Avago Optoisolator Compliance Summary for UL 840

UL 840 is not a stand alone equipment level safety standard, but is an insulation coordination safety standard. Various equipment manufacturers may refer either in part or in whole to the requirements of this standard.

Reconciliation of the UL 840 requirements for Creepage, Clearance, and Test voltages, as shown in Tables (3.25, 3.26, 3.27) indicates that Avago Technologies Optoisolator product groups will comply with the standards requirements under the following cases. Only a few cases are considered as examples, and the reader can readily interpret other cases by considering the compliance shown in the Tables (3.25, 3.26, 3.27):

- For installation category II and pollution degree 2 environment, Avago Optoisolator product group (A) will comply with the UL 840 requirements at a working voltage of 1000 V rms or lower.
- For installation category II and pollution degree 2 environment, Avago Optoisolator product groups (A, B) will comply with the UL 840 requirements at a working voltage of 800 V rms or lower.
- For installation category II and pollution degree 2 environment Avago Optoisolator product groups (A, B, C) will comply with the UL 840 requirements at a working voltage of 630 V rms or lower. Groups (A, B, C, D) will comply under similar conditions at a working voltage of 400 V rms or lower.

**Table 3.24 UL 840 Clearance Compliance
Avago Optoisolator Product Groups*
Insulation Coordination for Electrical Equipment**

Phase-to-ground* rated system voltage (rms and dc)				Rated Impulse Withstand Voltage peak, KV**	Avago Optoisolator Product Groups* Pollution degree			
Overvoltage Category					1	2	3	4
I	II	III	IV					
50				0.33	A,B,C,D,E,F,G	A,B,C,D,E,F,G	A,B,C,D,E,F,G	A,B,C,D,E,F,G
100	50			0.5	A,B,C,D,E,F,G	A,B,C,D,E,F,G	A,B,C,D,E,F,G	A,B,C,D,E,F,G
150	100	50		0.8	A,B,C,D,E,F,G	A,B,C,D,E,F,G	A,B,C,D,E,F,G	A,B,C,D,E,F,G
300	150	100	50	1.5	A,B,C,D,E,F,G	A,B,C,D,E,F,G	A,B,C,D,E,F,G	A,B,C,D,E,F,G
600	300	150	100	2.5	A,B,C,D,E,F,G	A,B,C,D,E,F,G	A,B,C,D,E,F,G	A,B,C,D,E,F,G
1000	600	300	150	4	A,B,C,D,E,F,G	A,B,C,D,E,F,G	A,B,C,D,E,F,G	A,B,C,D,E,F,G
1500	1000	600	300	6	A, B, C	A, B, C	A, B, C	A, B, C
	1500	1000	600	8	A	A	A	A
		1500	1000	12				
			1500	16				

* NOTES:

- See Table 2.1 for Avago Optoisolator Product Groups:
Group A = 400 mil Widebody Package (H/ACNW/HCNR),
Group B = 300 mil DIP Package (HCPL-7XXX/JXXX) and SO-16 package (HCPL-XXXJ),
Group C = 300 mil DIP Package (HCPL-XXXX),
Group D = SO-8 Package.
Group E = SO-5 Package.
Groups F & G = Stretch SO Packages.
- Reconcile requirements of each compliance Table (3.24, 3.25, 3.26) for product compliance to the UL 840 safety standard.
- This table may be used to evaluate clearances where the levels of overvoltage are controlled.
- See Table 8.1, UL 840 Minimum Clearances for Equipment, for further details.

**Table 3.25 UL 840 Creepage Compliance
Avago Optoisolator Product Groups*
Insulation Coordination For Electrical Systems**

Operating Voltage Vrms or dc	Pollution degree 1	Pollution degree 2	Pollution degree 3	Pollution degree 4
< 125	A, B, C, D, E, F, G	A, B, C, D, E, F, G	A, B, C, D, E, F, G	A, B, C, D, E, F, G
160	A, B, C, D, E, F, G	A, B, C, D, E, F, G	A, B, C, D, E, F, G	A, B, C, E, F, G
200	A, B, C, D, E, F, G	A, B, C, D, E, F, G	A, B, C, D, E, F, G	A, B, C, E, F, G
250	A, B, C, D, E, F, G	A, B, C, D, E, F, G	A, B, C, D, E, F, G	A, B, G
320	A, B, C, D, E, F, G	A, B, C, D, E, F, G	A, B, C, E, F, G	A
400	A, B, C, D, E, F, G	A, B, C, D, E, F, G	A, B, C, F, G	
500	A, B, C, D, E, F, G	A, B, C, E, F, G	A, B, G	
630	A, B, C, D, E, F, G	A, B, C, E, F, G	A	
800	A, B, C, D, E, F, G	A, B, G		
1000	A, B, C, D, E, F, G	A		
1250	A, B, C, D, E, F, G			
1600	A, B, C, F, G			
2000	A, B, G			

* NOTES:

- See Table 2.1 for Avago Optoisolator Product Groups:
Group A = 400 mil Widebody Package (HCNW/HCNR),
Group B = 300 mil DIP Package (HCPL-7XXX/JXXX) and SO-16 package (HCPL-XXXJ),
Group C = 300 mil DIP Package (HCPL-XXXX),
Group D = SO-8 Package.
Group E = SO-5 Package.
Groups F & G = Stretch SO-Packages.
- Reconcile requirements of each compliance Table (3.24, 3.25, 3.26) for product compliance to the UL 840 safety standard.
- See Table 9.1, UL 840 Minimum Acceptable Creepage Distances, for further details.
- Creepage Values shown are for Material Group IIIa only.
- This table is applicable for equipment subject to long-term stress.
- Creepage distances will be based on Tables 9.1 or 9.2.
- Creepage values are a function of the operating voltage across the insulation, comparative tracking index (CTI), and the level of pollution expected or controlled at the creepage distance.
- For Printed wiring boards using Table 9.2, the existence of recurring voltages is to be evaluated per Table 9.3.

**Table 3.26 UL 840 Creepage Compliance On Printed Wiring Boards
Avago Optoisolator Product Groups*
Insulation Coordination For Electrical Equipment**

Operating Voltage Vrms or dc	Avago Optoisolator Product Groups* Pollution Degree	
	1*	2**
< 400	A, B, C, D, E, F, G	A, B, C, D, E, F, G
500	A, B, C, D, E, F, G	A, B, C, D, E, F, G
630	A, B, C, D, E, F, G	A, B, C, D, E, F, G
800	A, B, C, D, E, F, G	A, B, C, D, E, F, G
1000	A, B, C, D, E, F, G	A, B, C

* NOTES:

1. See Table 2.1 for Avago Optoisolator Product Groups:
Group A = 400 mil Widebody Package (H/ACNW/HENR),
Group B = 300 mil DIP Package (HCPL-7XXX/JXXX) and SO-16 package (HCPL-XXXJ),
Group C = 300 mil DIP Package (HCPL-XXXX),
Group D = SO-8 Package.
Group E = SO-5 Package.
Groups F & G = Stretch SO Packages.
2. Reconcile requirements of each compliance Table (3.24, 3.25, 3.26) for product compliance to the UL 840 safety standard.
3. See Table 9.2, Minimum Creepage Distance on Printed Wiring Boards, for further details.
- *4. This column is applicable to Material Group I, II, IIIa, IIIb.
- **5. This column is applicable for Material Group I, II, IIIa. For Material Group IIIb use Table 9.1.
6. This Table provides values for Pollution degrees 1 and 2. For Pollution Degree 3 and 4 use Table 9.1.
7. Creepage values are a function of the operating voltage across the distance, comparative tracking index (CTI), and the level of pollution expected or controlled at the creepage distance.
8. For Printed wiring boards using Table 9.2, the existence of recurring voltages is to be evaluated per Table 9.3.
9. For pollution degree 2, the CTI of the printed wiring board must be at least 175.

Chapter 4 Synopsis of Key Regulatory Specifications

4.0 How To Use The Regulatory Synopsis Information

Chapter 4 contains a brief regulatory summary of key electrical safety requirements of each of the International or National safety standards addressed in Chapter 3. These summaries only address electrical safety requirements of each standard as indicated through the insulation coordinates (creepage, clearance, or through distance insulation) and test voltage requirements.

The purpose of these summaries is to provide an overview of the electrical safety requirements and pertinent safety parameters of the standard. Key safety standard parameters that have been summarized in these tables are requirements for creepage distance, clearance distance, and test voltage requirements.

The synopsis by its very nature and brevity cannot do full justice to the details and elaboration that are included in the actual document or a safety standard. Thus, in case you desire to find further details of a safety standard, we encourage you to obtain the actual safety standard that you may be interested in. Most safety standard documents can be obtained from the American National Standards Institute located in New York. Or, the document can be purchased directly from the home address of each agency. See the Appendices for pertinent agency addresses.

Once again, Avago Technologies takes this opportunity to disclaim any or implied equipment level safety standard approval to any of the equipment standards or insulation coordination standards discussed in this chapter as they pertain to Avago optoisolators. The information provided in this chapter is provided as a service to Avago optoisolator component users. It is the equipment manufacturer's responsibility to have their equipment approved through appropriate safety standard agency.

4.1 International Standard IEC 61010-1:

Safety Requirements for Electrical Equipment for Measurement, Control, and Laboratory Use.

This is an international safety standard that specifies general safety requirements for electrical equipment for professional, industrial process, and educational use. This includes any peripheral electrical equipment or accessories or computing devices that may be used in conjunction with measurement and test equipment, control devices, or laboratory use devices.

For instance, electrical measurement and test equipment may include any measurement and recording devices such as computers, oscilloscopes, main frame testers, etc. Non-measuring electrical equipment such as signal generators, power supplies, transducers, transmitters, etc., are also within the scope of this standard. Electrical control equipment can be any equipment that controls an output as a function of some input control variable such as programmable logic controllers (PLCs) etc. Electrical Laboratory Equipment is any equipment which measures, indicates, monitors or analyzes substances, or is used to prepare materials.

Environmental Conditions

This standard applies to equipment designed to be safe at least under the following conditions: Indoor use, altitude up to 2000 m, temperature 5°C to 40°C, maximum relative humidity 80% for temperature up to 31°C, decreasing linearly to 50% relative humidity at 40°C. The mains supply voltage fluctuations not to exceed $\pm 10\%$ of nominal value (other supply voltage fluctuations as stated by manufacturer). Transient overvoltages (Table 4.1.1) are according to Installation Categories (Overvoltage Categories) I, II, and III. For mains supply the minimum and normal category is II. The Pollution Degree 1 or 2 in accordance with IEC 60664.

According to IEC 60664 Insulating Materials are separated into four groups by their Comparative Tracking Index (CTI) values as specified in IEC 112. For more information see IEC 60664. All of Avago Technologies optoisolators are molded from material group IIIa, and have CTI >200.

- Material Group I: 600 < CTI
- Material Group II: 400 < CTI < 600
- Material Group IIIa: 175 < CTI < 400
- Material Group IIIb: 100 < CTI < 175

Table 4.1.1 Maximum Transient Overvoltages vs. Installation Category

Voltage 3-phase 4-wire systems (V)	Voltages 3-phase 3-wire systems (V)	Voltages phase-to-earth (V)	Maximum Transient Overvoltage (V)		
			Installation Category (I)	Installation Category (II)	Installation Category (III)
		50	330	500	800
66/115	120	100	500	800	1500
120/208 120/240	240	150	800	1500	2500
230/400 277/480	500	300	1500	2500	4000
400/690	1000	600	2500	4000	6000
		1000	4000	6000	8000

Clearance and Creepage Distances

The installation category (overvoltage category) is established by the maximum transient overvoltages that a circuit experiences, and thus influences the clearance dimensions. The minimum creepage distance allowed is at least as large as the clearance dimension.

Tables 4.1.2 and 4.1.3 specify Clearances and Creepage Distances in relation to working voltage, as derived from IEC 60664. The tables specify values with respect to working voltage, and is defined as “the highest r.m.s. values of the a.c. or d.c. voltage which may occur (locally) across any insulation at rated supply voltage, transients being disregarded”.

**Table 4.1.2 IEC 61010-1 Clearance / Creepage Requirements
Safety Requirements for Electrical Equipment for Measurement, Control, and Laboratory Use**

Working Voltage V rms or dc	Insulation Level	Pollution Degree 1					
		Installation Category I		Installation Category II		Installation Category III	
		Clearance mm	Creepage mm	Clearance mm	Creepage mm	Clearance mm	Creepage mm
50	Basic	0.1	0.1	0.1	0.1	0.1	0.1
	Reinforced	0.1	0.1	0.12	0.12	0.4	0.4
100	Basic	0.1	0.1	0.1	0.1	0.5	0.5
	Reinforced	0.12	0.2	0.4	0.4	1.6	1.6
150	Basic	0.1	0.22	0.5	0.5	1.5	1.5
	Reinforced	0.4	0.45	1.6	1.6	3.3	3.3
300	Basic	0.5	0.7	1.5	1.5	3	3
	Reinforced	1.6	1.6	3.3	3.3	6.5	6.5
600	Basic	1.5	1.7	3	3	5.5	5.5
	Reinforced	3.3	3.4	6.5	6.5	11.5	11.5
1000	Basic	3	3.2	5.5	5.5	8	8
	Reinforced	6.5	6.5	11.5	11.5	16	16

Notes:

1. IEC 61010-1 safety standard derives the creepage / clearance distances from IEC 60664.
2. Table lists creepage values for printed wiring boards (not coated)

**Table 4.1.3 IEC 61010-1 Clearance / Creepage Requirements
Safety Requirements for Electrical Equipment for Measurement, Control, and Laboratory Use**

Working Voltage V rms or dc	Insulation Level	Pollution Degree 2					
		Installation Category I		Installation Category II		Installation Category III	
		Clearance mm	Creepage mm	Clearance mm	Creepage mm	Clearance mm	Creepage mm
50	Basic	0.2	0.2	0.2	0.2	0.2	0.2
	Reinforced	0.2	0.4	0.2	0.4	0.4	0.5
100	Basic	0.2	0.2	0.2	0.2	0.5	0.5
	Reinforced	0.2	0.4	0.4	0.4	1.6	1.6
150	Basic	0.2	0.35	0.5	0.5	1.5	1.5
	Reinforced	0.4	0.7	1.6	1.6	3.3	3.3
300	Basic	0.5	1.4	1.5	1.5	3	3
	Reinforced	1.6	2.8	3.3	3.3	6.5	6.5
600	Basic	1.5	3	3	3	5.5	5.5
	Reinforced	3.3	6	6.5	6.5	11.5	11.5
1000	Basic	3	5	5.5	5.5	8	8
	Reinforced	6.5	10	11.5	11.5	16	16

Notes:

1. IEC 61010-1 safety standard derives the creepage / clearance distances from IEC 60664.
2. Table lists creepage values for printed wiring boards (not coated)

Test Voltages

Table 4.1.4 lists the test voltages for establishing compliance for respective creepage and clearance of the insulation. Compliance is established if no breakdown or repeated flashover occurs. For the purposes of this safety standard, corona and similar phenomenon are not considered.

This safety standard offers three different test voltage options: Peak impulse test, a.c. test, or a d.c. test. Equipment or component has to pass any one of the three listed alternative test voltages.

Peak impulse test is the 1.2/50 μ s test specified in IEC 60, and is conducted for a minimum of 3 pulses of each polarity at 1 s minimum interval. The a.c. and d.c. tests are conducted with the voltage raised gradually within 10 s to the specified value (with no appreciable transient occurring), and the voltages are maintained for 1 minute.

**Table 4.1.4 IEC 61010 Test Voltages for Dielectric Strength Tests
Safety Requirements for Electrical Equipment for Measurement, Control, and Laboratory Use**

Working Voltage V rms or dc	Insulation Level	Pollution Degree 1 or 2											
		Installation Category I				Installation Category II				Installation category III			
		Test Voltage	Test Voltage	Test Voltage	Test Voltage	Test Voltage	Test Voltage	Test Voltage	Test Voltage	Test Voltage	Test Voltage	Test Voltage	Test Voltage
50	Basic	Peak Impulse 1.2/50 μ s	rms 50/60 Hz (1 min)	dc or 50/60 Hz peak (1 min)	Peak Impulse 1.2/50 μ s	rms 50/60 Hz (1 min)	dc or 50/60 Hz peak (1 min)	Peak Impulse 1.2/50 μ s	rms 50/60 Hz (1 min)	dc or 50/60 Hz peak (1 min)	Peak Impulse 1.2/50 μ s	rms 50/60 Hz (1 min)	dc or 50/60 Hz peak (1 min)
	Reinforced	560	400	560	850	510	720	1360	740	1050	1360	740	1050
100	Basic	500	350	500	800	490	700	1500	820	1150	1500	820	1150
	Reinforced	850	510	720	1360	740	1050	2550	1400	1950	2550	1400	1950
150	Basic	800	490	700	1500	820	1150	2500	1350	1900	2500	1350	1900
	Reinforced	1360	740	1050	2550	1400	1950	4250	2300	3250	4250	2300	3250
300	Basic	1500	820	1150	2500	1350	1900	4000	2200	3100	4000	2200	3100
	Reinforced	2550	1400	1950	4250	2300	3250	6800	3700	5250	6800	3700	5250
600	Basic	2500	1350	1900	4000	2200	3100	6000	3250	4600	6000	3250	4600
	Reinforced	4250	2300	3250	6800	3700	5250	10200	5500	7850	10200	5500	7850
1000	Basic	4000	2200	3100	6000	3250	4600	8000	4350	6150	8000	4350	6150
	Reinforced	6800	3700	5250	10200	5550	7850	13600	7400	10450	13600	7400	10450

NOTES:

1. Any one of the three alternative test voltages can be used.
2. Impulse test is the 1.2/50 μ s test specified in IEC 60 (minimum of 3 pulses of each polarity, at 1 s min. interval).
3. Table lists dielectric strength test voltages derived from IEC 60664 (on printed wiring boards).

4.2 DIN VDE 0160 or EN50178:

Safety Requirements for Electronic Equipment For Use In Electrical Power Installations and Their Assembly Into Electrical Power Installations

VDE 0160 is a specification that regulates electronic equipment for use in electrical power installations inside Germany, but it has been withdrawn. It is replaced by EN50178 specification authored by CENELEC for Europe. A typical industrial application for optocouplers is inverters, which fall under this standard and specification.

This description is a short summary of only the EN50178 optoisolator requirements. EN50178 clearly describes certain requirements for creepage and clearance for printed circuit boards. Because optoisolators isolate the high voltages on the boards, these requirements become external creepage and external clearance requirements for the optoisolator.

Clearance

The current EN50178 requirements for clearance are outlined in referenced specifications, IEC60664-1. To determine the clearance requirement for the optoisolator, certain parameters are needed – the overvoltage category (or application class), basic or reinforced insulation requirement, as well as the incoming line voltage for the equipment. Another parameter is the pollution degree. Since printed circuit boards are usually in

pollution degree 2 environment or lower, this summary assumes that the optoisolator is in a pollution degree 2 environment.

The overvoltage category 2 is applicable for mains supply connected to movable equipment (examples of such equipment are appliances, portable tools, and other household equipment). Whereas, the overvoltage category 3 applies when the equipment is in a fixed installation (examples of such equipment are appliances, portable tools, and other household equipment). Whereas, the overvoltage category 3 applies when the equipment is in a fixed installation (examples of such equipment are switches in the fixed installation and equipment for industrial use with permanent connection to the fixed installation). A simplification is to say that category 2 means that the equipment has a removable plug connector and category 3 involves hard wiring to the building supply line. Per EN50178 the equipment manufacturer must select using basic insulation or reinforced insulation; basic insulation makes for easier component selection but poses other design issues for the equipment.

Table 4.2.1 Clearance Requirements vs. Transient Overvoltage Application Class II, Pollution Degree 2

Line Voltage Vrms or dc	Transient Overvoltage Vrms or dc	Basic Insulation Clearance mm	Reinforced Insulation Clearance mm
120 – 240 V 1 Phase	1500	0.5	1.5
up to 277 V 3 Phase	2500	1.5	3
up to 400 V 3 Phase	4000	3	5.5
1000 V	6000	5.5	8

Table 4.2.2 Clearance Requirements vs. Transient Overvoltage Application Class III, Pollution Degree 2

Line Voltage Vrms or dc	Transient Overvoltage Vrms or dc	Basic Insulation Clearance mm	Reinforced Insulation Clearance mm
120 – 240 V Single Phase	2500	1.5	3
up to 277 V 3 Phase	4000	3	5.5
up to 400 V 3 Phase	6000	5.5	8
1000 V	8000	8	14

Creepage

As with clearance, the EN50178 creepage requirements are described inside the referenced document of IEC 60664-1. As above, the pollution level is assumed to be pollution degree 2 for a printed circuit board with an optoisolator. The important parameters that determine creepage are the working voltage and basic versus reinforced insulation requirement. The definition of working voltage is the highest AC rms voltage or DC voltage that is placed across the part when the equipment is correctly operating. All Avago Technologies optoisolators are made using transfer molding compounds that belong to Material group IIIa as defined in IEC 60664-1.

Other Requirements

Creepage and clearance are directly described inside EN50178 and its referenced documents. Other requirements can be associated with EN50178, although the specification might only obliquely mention these other requirements. One example is the impulse voltage test, whereby a 1/50 ms impulse voltage is applied across the part. If the clearances are designed as described above, this routine test can be waived. The impulse test voltages match those for the transient overvoltage.

Per EN50178 the equipment must be subjected to an AC or DC voltage test, both as a qualification and a production test. The test time is 5 seconds for qualification and 1 second for routine testing, and the failure criteria is absence of flashover. The test voltage is dependent upon the rated insulation voltage, which is the recurring peak value of the

Table 4.2.3 Creepage Requirements vs. Working Voltage

Working Voltage Vrms or dc	Creepage Basic Insulation	Creepage Reinforced Insulation
200	2	4
250	2.5	5
320	3.2	6.4
400	4	8
500	5	10
630	6.3	12.6
800	8	16
1000	10	20

Table 4.2.4 Rated Insulation vs. Test Voltages

Rated Insulation Voltage Vrms	AC Test Voltages with Basic Insulation and Protective Separation Vrms	AC Test Voltage Between Circuits and Accessible Surface Vrms
230	1100	1800
300	1200	2200
400	1350	2600
600	1650	3500
690	1800	3800
1000	2250	5000

highest voltage appearing continuously across any two live parts of the equipment during operation. The insulation test voltage also varies with the voltage between circuits and accessible surfaces if the surface is not connected to protective earth. The test voltage is represented as AC rms, or the peak AC value can be used for a DC test. Interpolation is permitted.

Another requirement for the EN50178 equipment is to perform a partial discharge test. The requirement is that the equipment is subjected to 1.25 times the rated voltage, which is the recurring peak voltage value.

This requirement applies to the optoisolator, and partial discharge free optoisolators are currently available as DIN/VDE 0884 optoisolators. More detailed information regarding DIN/VDE 0884 optoisolators is available in this handbook. Avago Technologies has a full range of DIN/VDE 0884 optoisolators to meet this requirement.

This specification also refers to an impulse voltage requirement, which can be waived if the clearance requirements are satisfied without reduction or deviation.

4.3 International Standard IEC 60065:
Safety Requirements for mains operated electronic and related apparatus for household and similar general use

IEC 60065 is an International Standard that specifies safety requirements for household equipment intended for domestic and indoor use. Examples of this type of equipment are radios, VCRs, TVs, amplifiers, cable connected remote control device, motor driven devices etc. The standard applies to equipment for use for a 2000 m maximum altitude. This standard does not apply to equipment designed for a rated supply voltage that exceeds 433 V rms (between phases for a 3 phase supply) and 250 V rms in all other cases. Rated supply voltage is the supply mains voltage for which the manufacturer has designed the apparatus.

Attached Table 4.3.1 lists the creepage and clearance requirements versus the peak operating voltage. This voltage is construed as the peak supply mains voltage, which is the power source for the household equipment. For class I equipment, the accessible metal parts are separated from live parts by basic insulation. For class II equipment, the accessible metal parts are separated from live parts by reinforced insulation. The test voltages are applied for 1 minute. The minimum creepage and clearance shall be a minimum of 0.5 mm for basic insulation and 1 mm for reinforced insulation.

Insulation requirement for accessible parts and live parts shall be able to withstand transient surges. The insulation is subjected to 50 discharges at a maximum rate of 12 per minute, from a 1 nF capacitor charged to a 10 kV. The test circuit for the surge test is shown in figure 4.3.1. The insulation resistance after the surge test shall not be less than 2 Mohm at 500 V dc.

Apparatus will be able to operate in humid conditions, and compliance is established by test conditions described in IEC 68-2-3: Test Ca: Damp Heat, Steady State (temperature: 40°C, relative humidity: 90% to 95%).

The apparatus is kept in the humidity chamber for:

- 5 days (120 hours) for apparatus to be used under tropical conditions
- 2 days (48 hours) for other apparatus

The insulation resistance is tested with a 500 Vdc and should be a minimum of 2 Mohm for basic insulation and 4 Mohm for reinforced insulation.

For the measurement of dielectric strength, insulation test voltages are either AC peak voltage or dc voltage (see Table 4.3.1). Where corona, ionization charge effects may occur, a dc test voltage is recommended. The test voltages are applied for 1 minute. Compliance is established after the 1 minute test voltage, if insulation resistance specification is met (at the 500V dc test), and there is no flashover or breakdown.

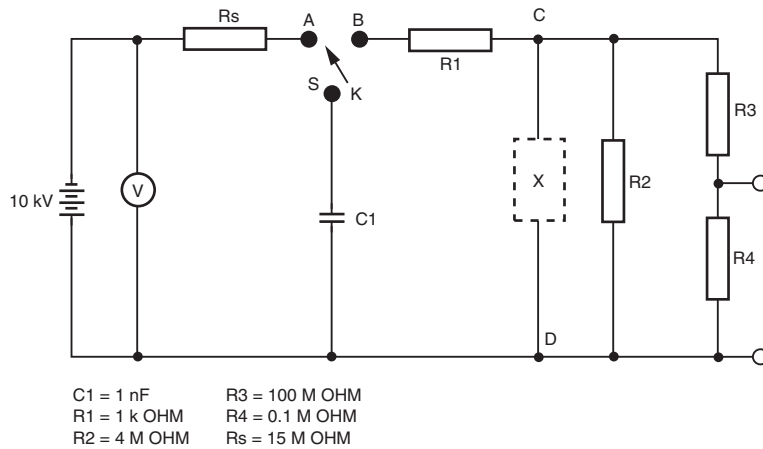

Figure 4.3.1 Circuit for Surge Test IEC 60065
Component Under Test Connected across Terminals C and D

Table 4.3.1 IEC 60065 Safety Requirements**Safety Requirements for mains operated electronic and related apparatus for household and similar general use**

Supply* Mains Voltage Vpeak	Insulation	Creepage mm	Clearance mm	Test Voltage Vpeak
34	Basic	0.6	0.6	707
	Reinforced	1.2	1.2	1410
70	Basic	1	1	1000
	Reinforced	2	2	2000
354	Basic	3	3	2120
	Reinforced	6	6	4240
500	Basic	4	4	2500
	Reinforced	6	6	4240
900	Basic	6	6	3000
	Reinforced	6	6	4240
1200	Basic	7	7	3800
	Reinforced	7	7	4240
1500	Basic	9	9	4000
	Reinforced	9	9	4240
2000	Basic	11	11	5000
	Reinforced	11	11	5000

Notes:

1. Class I equipment uses Basic Insulations, Class II equipment uses Reinforced Insulations.

*2. The voltages are determined with the apparatus connected to the rated supply voltage after the steady state has been reached.

4.4 International Standard 60601-1:

General Safety Requirements for Medical Electrical Equipment

The IEC 60601-1 safety standard specifies general requirements for the safety of Medical Electrical Equipment and serves as a basis for particular standards. The particular standards take priority in case of any conflicting requirements of the general standard and a particular standard.

Class I equipment is that equipment that does not rely on basic insulation only, but has additional safety precautions such that any accessible parts do not become live in the event of a failure of the basic insulation. Class II equipment is that equipment that does not rely on basic insulation only, but additional safety such as double insulation or reinforced insulation is provided.

This safety standard requires that insulation, components, and construction features the failure of which could produce a safety hazard shall be tested for compliance of the standard. Only insulations with a safety function need be subject to testing. Equipment is classified according to:

- a. Type of protection against electric shock and power source
- b. Degree of protection against electric shock
- c. Methods of sterilization recommended by manufacturer
- d. Flammability
- e. Mode of operation (continuous or intermittent)

The equipment in this standard is capable of operating in an ambient temperature range of +10°C to + 40°C, relative humidity range of 30% to 75%, and atmospheric pressure range of 500 hPa to 1060 hPa.

Table 4.4.1 lists the creepage, clearance, and test voltages for basic and reinforced insulation. The dielectric strength of the electrical insulation shall be able to meet the test voltages indicated in the table. The test time for the test voltages is 1 minute. The reference voltage indicated in Table 4.4.1 is the voltage to which an insulation is subjected to in normal use and rated supply voltage (or a voltage as specified by the manufacturer, whichever is greater).

**Table 4.4.1 IEC 60601-1 Safety Standard Requirements
General Safety Requirements for Medical Electrical Equipment**

Reference* Voltage dc	Reference* Voltage ac	Insulation	Creepage mm	Clearance mm	Test Voltage (1 minute) V rms
15	12	Basic	1.7	0.8	500
		Reinforced	3.4	1.6	500
34	30	Basic	2	1	500
		Reinforced	4	2	500
75	60	Basic	2.3	1.2	1000
		Reinforced	4.6	2.4	3000
150	125	Basic	3	1.6	1000
		Reinforced	6	3.2	3000
300	250	Basic	4	2.5	1600
		Reinforced	8	5	4200
450	380	Basic	6	3.5	1900
		Reinforced	12	7	4800
600	500	Basic	8	4.5	2200
		Reinforced	16	9	5400
800	660	Basic	10.5	6	2600
		Reinforced	21	12	6200
900	750	Basic	12	6.5	2800
		Reinforced	24	13	6600
1200	1000	Basic	16	9	3200
		Reinforced	32	18	7400

Notes:

- *1. Reference voltage is the voltage which the relevant insulation is subjected to in NORMAL USE and RATED supply voltage, whichever is greater.
- 2. Class I equipment uses Basic Insulations, Class II equipment uses Reinforced Insulations.

**4.5 International Standard IEC 60664-1:
Insulation Coordination for Equipment Within Low-Voltage
Systems**

IEC 60664-1 safety standard addresses insulation coordination for equipment within low voltage systems. It applies to equipment for use up to 2000 m elevation (extrapolation to higher elevations is allowed), a rated voltage up to 1000 V a.c. with rated frequencies up to 30 kHz or a rated voltage up to 1500 V d.c. This standard specifies the requirements for clearances, creepage distances and solid insulation, and includes methods of electric testing with respect to insulation coordination.

IEC 60664-1 is a basic safety standard and is a guide for Technical Committees responsible for different equipment in order to rationalize their requirements so that insulation coordination is achieved. The insulation coordination is the mutual correlation of insulation characteristics of electrical equipment taking into account the expected microenvironments or voltage environments to which the equipment will be subjected to in their normal use. In other words, the insulation coordination indicates the selection of the electric insulation characteristics of the equipment with regard to its application, and takes into account the working voltage, rated voltage, and rated insulation voltage of the equipment.

The insulation coordination uses a preferred series of rated impulse voltages indicated in Table 4.5.1 for equipment energized directly from the low-voltage mains:

IEC 60664-1 insulation coordination standard also indicates that consideration shall be given with regard to recurring peak voltages and to the extent partial-discharge can occur in solid insulation. The micro-environmental conditions are taken into account as quantified by pollution degree. For the purposes of evaluating creepage distances and clearances four degrees of pollution degrees are established:

- a. Pollution Degree 1: No pollution or only dry, non-conductive pollution occurs, and pollution has no significant impact. Air-conditioned office environments and labs are an example of pollution degree 1 environment.
- b. Pollution Degree 2: Only non-conductive pollution occurs except that occasionally a temporary conductivity caused by condensation is to be expected. Home environments can be considered pollution degree.
- c. Pollution Degree 3: Conductive pollution occurs or dry non-conductive pollution occurs which becomes conductive due to condensation which is to be expected. Industrial warehouses or factory floors may be construed as pollution degree 3 environments.
- d. Pollution Degree 4: The pollution generates persistent conductivity caused by conductive dust or by rain or snow. Areas exposed to outside atmosphere can be classified as pollution degree 4 environments.

**Table 4.5.1 IEC 60664-1 Rated Impulse Voltage
Insulation Coordination for Equipment within Low-Voltage Systems**

Nominal Voltage of the Supply System V		Voltage Line to Neutral a.c. or d.c V	Rated Impulse Voltage V			
Three Phase	Single Phase		Overvoltage Category			
			I	II	III	IV
		50	330	500	800	1500
		100	500	800	1500	2500
	120-540	150	800	1500	2500	4000
230/400*		300	1500	2500	4000	6000
277/480*						
400/690		600	2500	4000	6000	8000
1000		1000	4000	6000	8000	12000

Notes:

*1. The / mark indicates a four-wire threephase distribution system. The lower value is the voltage line to neutral, while the higher value is the voltage line-to-line. Where only one value is indicated, it refers to three wire, three phase systems and specifies the value line-to-line.

Equipment is dimensioned based on overvoltage category according to the expected use of the equipment. Four Overvoltage categories are established: I, II, III, and IV:

- a) Overvoltage Category I: Equipment of overvoltage category I is equipment for connection to circuits in which measures are taken to limit transient overvoltages to an appropriately low voltage. Circuits or equipment in this category are well isolated from mains supply. If the voltage were below 42.4 V it would be considered SELV (safety extra low voltage). Protected electronic circuits fall in this category.
- b) Overvoltage Category II: Equipment of overvoltage category II is equipment that receives its energy or power from a fixed installation or receptacle from power mains. Examples of such equipment or circuits are home appliances and power tools.
- c) Overvoltage Category III: Equipment of overvoltage category III is equipment in fixed installations. Category III is the mains distribution in the building, including duplex outlets. Examples of such equipment are switches in the fixed installation and equipment for industrial use with permanent connection to the fixed installation.
- d) Overvoltage Category IV: Equipment of overvoltage category IV is for use at the origin of the installation. Examples of such equipment are electricity meters and primary overcurrent protection equipment.

This standard also uses the comparative tracking index (CTI) to classify the insulation materials. Materials are separated into four groups according to their CTI values, as follows:

- Material Group I 600 < CTI
- Material Group II 400 < CTI < 600
- Material Group IIIa 175 < CTI < 400
- Material Group IIIb 100 < CTI < 175

The test for comparative tracking index (CTI) is according to IEC 112. This test consists of dropping aqueous contaminant on insulation placed on a horizontal surface and determining voltage when electrolytic conduction takes place. This test provides both a qualitative and a quantitative comparison between insulation materials having a tendency to arc or form tracks in the presence of voltages.

Dimensioning of Clearances

Clearances shall be dimensioned to withstand the required impulse withstand voltage up to an elevation of 2000 m per tables 4.5.2 and 4.5.3. The clearances of basic insulation shall be as indicated in this table.

Clearances of reinforced insulation shall be one step higher in the preferred series of values that are specified in the table below than that specified for basic insulation. For intermediate values of the impulse withstand values of the preferred series, reinforced values are to withstand 160% of the impulse withstand voltage required for basic insulation. For higher elevation than 2000 meter, this standard also specifies altitude correction factors for clearances.

Dimensioning of Creepage Distances

Creepage distances will be according to table 4.5.4, and takes into account the working voltage (long-term r.m.s. value) across the insulation, and also the influence of the micro-environment as indicated by the pollution degree. A creepage distance cannot be less than the associated clearances (shortest creepage is equal to required clearance). There is no physical relationship between the creepage distances and the clearance distance, other than the dimensional limitation indicated. Reinforced insulation will have creepage distances that are twice the value of the voltage specified for basic insulation.

Requirements of Solid Insulation

Design of solid insulation requires attention to the partial discharge phenomenon. In particular a solid insulation subjected to high frequencies is more sensitive to partial discharges. Accelerated life testing indicates that time to failure is inversely proportional to the frequency of the applied voltage. According to this standard there is no clear relationship between the thickness of the insulation and failure mechanisms related to frequency of operation or partial discharges, hence the performance of the solid insulation can only be assessed through testing. This standard does not, therefore, specify any minimum thickness of solid insulation to achieve long-term withstand capability. Partial discharge testing is applicable for components or small assemblies or small equipment.

Verification Tests

For verifying clearances the test voltages are in accordance with withstand voltage requirements (rated impulse withstand voltages). An impulse test is only required for clearances smaller than the values listed in tables 4.5.2 and 4.5.3.

An impulse dielectric test is used to verify that clearances will withstand specified transient overvoltages (this test is carried out with a voltage having 1.2/50 µsec waveform). This test is conducted for a minimum of three impulses of each polarity with an interval of at least 1s between pulses. The table below lists the voltage values for the verification of clearances only.

**Table 4.5.2 IEC 60664-1 Minimum Clearances For Insulation Coordination
Insulation Coordination for Equipment within Low-Voltage Systems**

Required Impulse Withstand Voltage kV	Minimum Clearances in Air up to 2000 m (mm) Basic Insulation(Inhomogenous Electric Fields) Pollution Degrees			
	1	2	3	4
0.33 *	0.01	0.04	0.8	1.6
0.4	0.02	0.04	0.8	1.6
0.5*	0.04	0.04	0.8	1.6
0.6	0.06	0.2	0.8	1.6
0.8*	0.1	0.2	0.8	1.6
1	0.15	0.2	0.8	1.6
1.2	0.25	0.25	0.8	1.6
1.5*	0.5	0.5	0.8	1.6
2	1	1	1	1.6
2.5*	1.5	1.5	1.5	1.6
32222				
4*3333				
54444				
6*	5.5	5.5	5.5	5.5
8*8888				
10	11	11	11	11
12*	14	14	14	14

Notes:

*1. Preferred Values Indicated in Table 4.5.1.

2. For printed wiring material, the values for pollution degree 1 apply except that the value shall not be less than 0.04 mm.

3. These minimum clearances given for pollution degree 2, 3, 4 are based on experience rather than on fundamental data.

**Table 4.5.3 IEC 60664-1 Minimum Clearances For Insulation Coordination
Insulation Coordination for Equipment within Low-Voltage Systems**

Required Impulse Withstand Voltage kV	Minimum Clearances in Air up to 2000 m (mm) Reinforced Insulation(Inhomogenous Electric Fields) Pollution Degrees			
	1	2	3	4
0.33*	0.04	0.04	0.8	1.6
0.4	0.1	0.1	0.8	1.6
0.5*	0.1	0.2	0.8	1.6
0.6	0.15	0.15	0.8	1.6
0.8*	0.5	0.5	0.8	1.6
1	1	1	1	1.6
1.2	1	1	1	1.6
1.5*	1.5	1.5	1.5	1.6
23333				
2.5*	3	3	3	3
34444				
4*	5.5	5.5	5.5	5.5
58888				
6*8888				
8*	14	14	14	14
10	25	25	25	25
12*	25	25	25	25

Notes:

- *1. Preferred Values Indicated in Table 4.5.1.
- 2. For printed wiring material, the values for pollution degree 1 apply except that the value shall not be less than 0.04 mm.
- 3. These minimum clearances given for pollution degree 2, 3, 4 are based on experience rather than on fundamental data.

**Table 4.5.4 IEC 60664-1 Minimum Creepage Distances versus Working Voltage
Insulation Coordination for Equipment within Low-Voltage Systems**

Working Voltage V rms	Insulation Level	Minimum Creepage Distances (mm)	
		Pollution Degree 2 Material Group III	Pollution Degree 3 Material Group III*
100	Basic	1.4	2.2
	Reinforced	2	3.2
125	Basic	1.5	2.4
	Reinforced	2.5	4
160	Basic	1.6	2.5
	Reinforced	3.2	5
200	Basic	2	3.2
	Reinforced	4	6.3
250	Basic	2.5	4
	Reinforced	5	8
320	Basic	3.2	5
	Reinforced	6.4	10
400	Basic	4	6.3
	Reinforced	8	12.5
500	Basic	5	8
	Reinforced	10	16
630	Basic	6.3	10
	Reinforced	12.6	20
800	Basic	8	12.5
	Reinforced	16	25
1000	Basic	10	16
	Reinforced	20	32

Notes:

*1. Material group IIIb is not recommended for application in pollution degree 3 above 630 V and in pollution degree 4.

**Table 4.5.5 Test Voltages for Verifying Clearances
(at sea level)**

Rated Impulse Voltage kV	Impulse Test Voltage kV
0.33	0.35
0.5	0.55
0.8	0.91
1.5	1.75
2.5	2.95
4	8.0
6	7.3
8	9.8
12	18.0

4.6. International Standard IEC 60950:

Safety of Information Technology Equipment, Including Electrical Business Equipment

IEC 60950 is a well known international standard which specifies the requirements for equipment connected directly to a tele-communication network. This type of equipment includes work stations, personal computers, printers, facsimile machines, cash registers, mail processing machines, document shredders, plotters, postage machines, modems and many more associated with telecommunication. IEC 60950 is not limited to, but it is often associated with office equipment. The rated voltage of IEC 60950 equipment is not to exceed **600 V** and is applicable to **Installation Category II**. Many country agencies have adopted IEC 60950 as their own standard for office and related equipment.

Regarding optocouplers used for insulation, IEC 60950 provides its own detailed **creepage** and **clearance** tables, as well as two other requirements which impact the use of optocouplers within the IEC 60950 environment: **electric strength test** and **distance through insulation**. These requirements are all interrelated and are affected by not only creepage and clearance of the optocoupler, but also the equipment mains voltage, installation class of the equipment, pollution degree environment, comparative tracking index (CTI) of the optocoupler outermold compound (which categorizes the mold compound to a material group) and insulation level required (operational, basic, supplementary, reinforced). The majority of IEC 60950 applications using opto-couplers are at the **reinforced** level.

Note: There is no minimum Distance Through Insulation for Optocouplers which comply with IEC60747-5-5.

Electric Strength Test

“The electric strength of the insulating materials used within the equipment shall be adequate.”

Table 4.6.1 (IEC 60950) shows the minimum test voltages for insulation levels and working voltage ranges. Optocouplers need to be capable of meeting the electric strength tests in Table 4.6.1 and are rated according to their dielectric withstand voltage, which is the capability of a device to withstand without breakdown for 60 seconds, a potential difference equal to the dielectric insulation voltage applied between the input and output leads of an optocoupler. A dielectric voltage rating is not to be interpreted as an input-output continuous working voltage.

In Table 4.6.1, “BODY” refers to all accessible conductive parts, shafts of handles, knobs, grips and the like, and metal foil in contact with all accessible surfaces of insulating material (see paragraph 1.2.7.5, IEC 60950). Table 4.6.1 has been summarized to include opto-coupler working voltages up to 1000 Vrms.

Table 4.6.1 Test Voltages for Electric Strength Tests, Part 1

		Test voltage volts r.m.s. (1 minute, 50 or 60 Hz) Points of application (as appropriate)				
		Primary to BODY Primary to secondary Between parts in PRIMARY CIRCUITS		Secondary to BODY Between independent secondaries		
Grade of Insulation	Working Voltage (U)	≤130 V r.m.s	130 V < U ≤ 250 V r.m.s.	250 V < U ≤1,000 V r.m.s	U ≤ 42.4 V peak, or 60 V d.c.	42.4 V peak or 60 V d.c. < U≤7 kV r.m. s.
	Operational	1000	1500	See Va in Table 4.6.1 Part 2	500	See Va in Table 4.6.1 Part 2
	Basic, Supplementary	1000	1500	"	No test	"
	Reinforced	2000	3000	3000	No test	See Vb in Table 4.6.1 Part 2

Part 2 of Table 4.6.1 lists sequential working voltages and the associated electric strength tests required for those unique working voltages. Avago Technologies optocouplers meet a minimum dielectric withstand voltage of 2500 Vrms, 3750 Vrms and 5000 Vrms. Other conditions

influence working voltage (creepage, distance through insulation, material group, pollution degree). Once working voltage is established, the required test voltage can be determined from Part 2. An abbreviated Part 2 table is presented below:

Table 4.6.1 Test Voltages for Electric Strength Test, Part 2, volts r.m.s.

Working Voltage U	Basic Va	Reinforced Vb	Working Voltage U	Basic Va	Reinforced Vb
24	500	800	268	1531	2450
30	558	887	280	1563	2500
37	611	978	305	1626	260
43	655	1048	347	1726	2762
61	771	1233	395	1833	2933
70	821	1314	415	1875	3000
102	978	1565	452	1951	3000
107	1000	1600	537	2114	3000
130	1000	1751	610	2242	3000
155	1188	1900	725	2429	3000
200	1337	2139	825	2579	3000
247	1474	2359	938	2738	3000
257	1502	2403	1000	2820	3000

Creepage

Table 4.6.2 provides the required minimum creepage distances for associated working voltages for **operational**, **basic** and **supplementary** insulation. For **reinforced** insulation, the creepage values are twice the values in table 4.6.2 for basic insulation. Pollution Degree (typically 2) and Material Group (CTI) are also needed. Pollution Degree 1 represents a clean room or laboratory with a controlled environment. Components and assemblies are sealed so as to exclude exposure to dust and moisture. Pollution Degree 2 represents the normal office environment. Pollution Degree 3 represents a “dirtier” environment, where equipment is subject to conductive pollution.

Material Group is based on the Comparative Tracking Index (CTI) rating obtained in accordance with IEC 112. All Avago Technologies optocouplers are molded from Material Group IIIa and have a CTI rating of 200:

- Material Group I $600 \leq \text{CTI}$
- Material Group II $400 \leq \text{CTI} < 600$
- Material Group IIIa $175 \leq \text{CTI} < 400$
- Material Group IIIb $100 \leq \text{CTI} < 175$

Table 4.6.2 Minimum Creepage Distances (mm)

Working Voltage up to and including V r.m.s. or d.c.	Pollution Degree 1 Material Group IIIa		Pollution Degree 2 Material Group IIIa		Pollution Degree 3 Material Group IIIa	
	O, B, S	R	O, B, S	R	O, B, S	R
50	Use appropriate Clearance from Table 4.6.3 or Table 4.6.5 for Pollution Degree 1		1.2	2.4	1.9	3.8
100			1.4	2.8	2.2	4.4
125			1.5	3.0	2.4	8.0
150			1.6	3.2	2.5	5.0
200			2.0	4.0	3.2	6.4
250			2.5	5.0	4.0	8.0
300			3.2	6.4	5.0	10.0
400			4.0	8.0	6.3	12.6
600			6.3	12.6	10.0	20.0
1000			10.0	20.0	16.0	32.0

O = Operational Insulation
 B = Basic Insulation
 S = Supplementary Insulation
 R = Reinforced Insulation

Clearance

IEC 60950 provides minimum clearance tables for **primary circuits** (Table 4.6.3) and **secondary circuits** (Table 4.6.5). For **primary circuits**, minimum clearances are specified according to the expected working voltage, nominal mains supply voltage and transient overvoltage ratings according to Installation Category II. Installation Category II includes equipment which derives its power from the building or installation power system, requiring the equipment to be “plugged in”. A primary circuit is an internal circuit which is directly connected to the external supply mains or other equivalent electric power source, such as a motor-generator set.

Secondary circuits have no direct connection to primary power and derive their power from a transformer, converter or equivalent isolation device situated within the equipment. Secondary circuits are subject to Installation Category I and the clearance values are specified in Table 5 under similar conditions as Table 4.6.3: expected working voltage, equipment mains supply voltage and transient overvoltage ratings. Clearance values are not as large as those required for primary circuits.

Clearance values in parentheses apply only if the equipment manufacturer has a quality control program in accordance with Annex R of IEC 60950 specification.

If the repetitive peak voltages in a primary circuit exceed the peak values of the mains supply voltage (up to 300V), then additional clearance must be included according to Table 4.6.4. The voltage values in parentheses apply only if the equipment manufacturer has a quality control program in accordance with Annex R.

**Table 4.6.3 Minimum Clearances for Insulation in primary circuits, and between primary and secondary circuits
Basic and Reinforced, mm**

Insulation working voltage up to and including		Circuits subject to installation Category II									
		Nominal mains supply voltage ≤150 V Transient rating 1,500 V				Nominal mains supply voltage > 150 V ≤300 V Transient rating 2,500 V				Nominal mains supply voltage > 300 V ≤600 V Transient rating 4,000V	
V peak or d.c. V	Vr.m.s. (sisusoidal) V	Pollution degrees 1 and 2		Pollution degree 3		Pollution degrees 1 and 2		Pollution degree 3		Pollution degrees 1, 2, and 3	
		B	R	B	R	B	R	B	R	B	R
71	50	1.0 (0.7)	2.0 (1.4)	1.3 (1.0)	2.6 (2.0)	2.0 (1.7)	4.0 (3.4)	2.0 (1.7)	4.0 (3.4)	3.2 (3.0)	6.4 (6.0)
210	150	1.0 (0.7)	2.0 (1.4)	1.3 (1.0)	2.6 (2.0)	2.0 (1.7)	4.0 (3.4)	2.0 (1.7)	4.0 (3.4)	3.2 (3.0)	6.4 (6.0)
420	300	B 2.0 (1.7) R 4.0 (3.4)								3.2 (3.0)	6.4 (6.0)
840	600	B 3.2 (3.0) R 6.4 (6.0)									
1400	1000	B 4.2 R 6.4									

B = Basic Insulation
R = Reinforced Insulation

Table 4.6.4 Additional clearances for insulation in primary circuits with repetitive peak voltages exceeding the peak value of the mains supply voltage

Nominal mains supply voltage ≤150 V		Nominal mains supply voltage >150 V ≤300 V		Additional clearance mm			
Pollution degrees 1 and 2		Pollution degree 3		Pollution degrees 1, 2 and 3			
Maximum repetitive peak voltage V	Maximum repetitive peak voltage V	Maximum repetitive peak voltage V	Maximum repetitive peak voltage V	Basic Insulation	Reinforced Insulation		
210	(210)	210	(210)	420	(420)	0	0
298	(290)	294	(300)	493	(497)	0.1	0.2
386	(370)	379	(390)	567	(574)	0.2	0.4
474	(450)	463	(480)	640	(651)	0.3	0.6
562	(530)	547	(570)	713	(728)	0.4	0.8
650	(610)	632	(660)	787	(805)	0.5	1.0
738	(690)	716	(750)	860	(881)	0.6	1.2
826	(770)	800	(840)	933	(985)	0.7	1.4
914	(850)	–	–	1006	(1035)	0.8	1.6
1002	(930)	–	–	1080	(1112)	0.9	1.8
1090	(1010)	–	–	1153	(1189)	1.0	2.0
–	–	–	–	1226	(1266)	1.1	2.2
–	–	–	–	1300	(1343)	1.2	2.4
–	–	–	–	–	(1420)	1.3	2.6

**Table 4.6.5 Minimum clearances in secondary circuits,
Basic and Reinforced, mm**

Insulation working voltage up to and including		Circuits subject to installation Category I											
		Nominal mains supply voltage ≤ 150 V (Transient rating of secondary circuit 800 V)				Nominal mains supply voltage > 150 V ≤ 300 V (Transient rating of secondary circuit 1500 V)				Nominal mains supply voltage > 300 V ≤ 600 V (Transient rating of secondary circuit 2500 V)		Circuits not subjected to transient overvoltage	
V peak or d.c. V	Vr.m.s. (sine wave) V	Pollution degrees 1 and 2		Pollution degree 3		Pollution degrees 1 and 2		Pollution degree 3		Pollution degrees 1, 2, and 3		Pollution degrees 1 and 2 only	
		B	R	B	R	B	R	B	R	B	R	B	R
71	50	0.7 (0.4)	1.4 (0.8)	1.3 (1.0)	2.6 (2.0)	1.0 (0.7)	2.0 (1.4)	1.3 (1.0)	2.6 (2.0)	2.0 (1.7)	4.0 (3.4)	0.4	0.8
140	100	0.7 (0.6)	1.4 (0.8)	1.3 (1.0)	2.6 (2.0)	1.0 (0.7)	2.0 (1.4)	1.3 (1.0)	2.6 (2.0)	2.0 (1.7)	4.0 (3.4)	0.7 (0.6)	1.4 (1.2)
210	150	0.9 (0.6)	1.4 (0.8)	1.3 (1.0)	2.6 (2.0)	1.0 (0.7)	2.0 (1.4)	1.3 (1.0)	2.6 (2.0)	2.0 (1.7)	4.0 (3.4)	0.7 (0.6)	1.4 (1.2)
280	200	B 1.4 (1.1) R 2.8 (2.2)								2.0 (1.7)	4.0 (3.4)	1.1	2.2
420	300	B 1.9 (1.6) R 3.8 (3.2)								2.0 (1.7)	4.0 (3.4)	1.4	2.8
700	500	B 2.5 R 5.0											
840	600	B 3.2 R 5.0											
1400	1000	B 4.2 R 5.0											

B = Basic Insulation
R = Reinforced Insulation

4.7 Underwriter Laboratories Inc. Standard for Safety UL508: Industrial Control Equipment

UL 508 is a safety standard that covers the area of industrial control devices that include devices for starting, stopping, controlling, and protecting electric motors. This standard covers devices rated up to 1500 V or less and intended for use in an ambient of 0°C to 40°C (32°F to 104°F). Examples of other industrial control devices where this standard is applicable are solid state starters and controllers, solid state relays, control circuit switches and relays, programmable controllers, solid state logic controllers, proximity switches, etc.

In order to achieve clearance and creepage requirements UL 508 provides for two options. First option is the requirements listed in the UL 508 standard itself. Second option allows that clearance and creepage distances may be evaluated in accordance with the guidelines of UL 840. The UL 840 is a Standard for Insulation Coordination for Electrical Equipment. The safety standard requirements summarized in this section are based on the UL 508 standard. The safety requirements or compliance based on the insulation coordination standard UL 840 are summarized in another section of this regulatory guide.

According to UL these requirements are based upon sound engineering principles, research, field experience, installation, and use derived from consultation with and information obtained from manufacturers. The observance of the requirements of this Standard by a manufacturer is one of the conditions of the continued coverage of the manufacturer's product.

UL 508 safety standard requires a dielectric voltage withstand test for verification purpose. While at its maximum normal operating temperature, industrial control equipment shall withstand 1 minute/ 60 Hz or a d.c. potential without breakdown. The test potential shall be the following values for or 1.414 times the following values for d.c.:

- a) 500 V – For industrial control equipment rated not more than 50 V
- b) 1000 V plus twice the rated voltage of the equipment – For all other industrial control equipment rated more than 50 Volts.
- c) 1000 V – For industrial control equipment rated more than 50 V but not more than 250 V and intended for use in pollution degree 2.

A surge-controlled circuit shall withstand without breakdown a single 1.2 by 50 μ sec full-wave impulse with a crest value of 5.0 kV. The transient voltage surge shall not exceed 300 percent of the peak working voltage, or 300 V, whichever is greater (see *Techniques for High Voltage Testing, ANSI/IEEE 4-1978*). Figure 4.7.1 shows a typical impulse generator which can generate the requisite waveform for this test. The impulse generator is connected across the equipment for this test, while the equipment is connected to a single-phase source of supply at rated voltage.

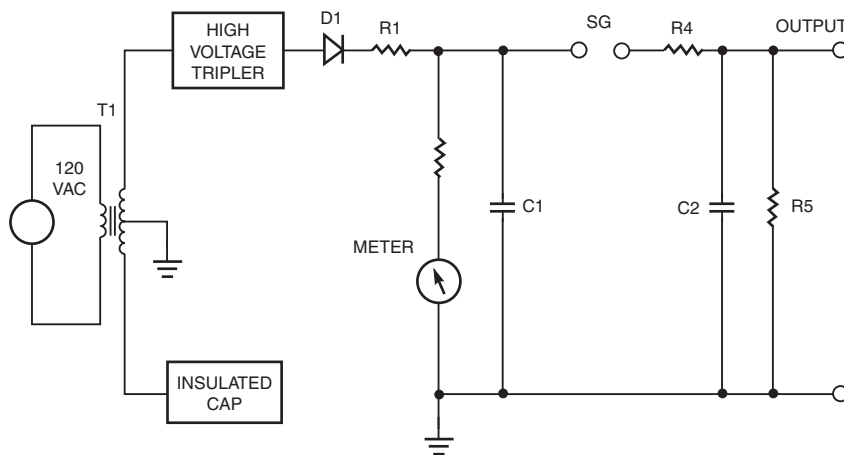

R4 IS 12 OHM SURGE RESISTOR
D1 IS DAMPER DIODE
T1 TRANSFORMER, 7500 VAC EACH SIDE OF CENTER TAP
SG SPARK GAP
R5 IS 350 OHM, 300 WATT

Figure 4.7.1 Typical Impulse Generator

**Table 4.7.1 UL 508 Creepage Requirements Between Traces of Opposite Polarity on Printed Wiring Boards
Safety Requirements for Industrial Control Equipment**

Volts** V rms or dc	Transient Voltages Not Limited		Transient Voltages Limited***	
	Coated**** mm	Uncoated mm	Coated**** mm	Uncoated mm
50	0.18	0.85	0.025	0.04
100	0.25	1	0.1	0.16
125	0.28	1.05	0.16	0.25
160	0.32	1.1	0.25	0.4
200	0.42	1.4	0.4	0.63
250	0.56	1.8	0.56	1
320	0.75	2.2	0.75	1.6
400	1	2.8	1	2
500	1.3	3.6	1.3	2.5
630	1.8	4.5	1.8	3.2
800	2.4	5.6	2.4	4
1000	3.2	7.1	3.2	5

NOTES:

1. This table is derived from Table IV of International Electrotechnical Commission, Publication 664A. Linear interpolation of values is permitted.

**2. Voltage between the traces where spacing is measured.

***3. The maximum recurring peak voltages shall not exceed the applicable value specified in Table 6.3 of UL 840 (see Table 4.7.2).

****4. The coating shall comply with the requirements of the Printed Wiring Board Coating Performance test, Section 12, in UL 840, or another equivalent method.

**Table 4.7.2 UL 508 Maximum Recurring Peak Voltage Related to Creepage on Printed Wiring Boards
Safety Requirements for Industrial Control Equipment**

Creepage Distance mm	Maximum Allowable Recurring Peak Voltage
0.025	330
0.1	360
0.2	400
0.25	450
0.4	600
0.5	640
0.75	800
1	913
1.3	1049
1.5	1140
1.8	1250
2	1314
2.4	1443
2.5	1475
3.2	1700
4	1922
5	2200

NOTES:

1. This table is derived from Table 6.3 of UL 840.

2. Voltage and creepage values may be interpolated linearly.

3. The maximum recurring peak voltages appearing across creepage distances on printed wiring boards shall be limited per this table.

**Table 4.7.3 UL 508 Minimum Acceptable Spacings
Safety Requirements for Industrial Control Equipment**

Potential Involved in Vrms or dc		Minimum Spacings (mm)							
		ABCD General Industrial Control Equipment			Devices having Limited Ratings*		Other Devices **		All Circuits ***
		50-150	151-300	301-600	51-300	301-600	51-150	151-300	0-50
Between any uninsulated live part and an uninsulated live part of opposite polarity, uninsulated grounded part other than the enclosure, or exposed metal part	Through air or oil (Clearance)	3.2	6.4	9.5	1.6	8.0	3.2	6.4	1.6
	Over Surface (Creepage)	6.4	9.5	12.7	3.2	9.5	6.4	6.4	1.6
Between any uninsulated live part and the walls of a metal enclosure including fitting for conduit or armored cable	Shortest Distance	12.7	12.7	12.7	6.4	12.7	6.4	6.4	6.4

NOTES:

*1. The spacings specified in column B of Table 4.7.3 are applicable to equipment:

(1) Rated 1 horsepower (746 W output) or equivalent FLA, or less, 720 volt-amperes break pilot duty or less; or not more than 15 amperes at 51 - 150 volts, 10 amperes at 151 - 300 volts, or 5 amperes at 301 - 600 volts.

(2) Of the type described in (1) which controls more than one load provided the total load connected to the line at one time does not exceed 2 horsepowers (1492 W output), 1440 volt-amperes, or have a current rating greater than 30 amperes at 51 - 150 volts, 20 amperes at 151 - 300 volts, or 10 amperes at 301 - 600 volts.

**2. The spacings specified in column C of table 4.7.3 apply only to equipment rated at 300 volts or less, and 1 horsepower (746 W output) or less or 2000 volt-amperes or less per pole and to a device that has a current rating per pole of 15 amperes or less at 51 -150 volts, 10 amperes at 301 -600 volts, or both.

***3. Spacings apply as indicated, except as specified in (4) and the spacings between the low potential circuit are in accordance with the requirements that are applicable to the high-potential circuit.

4. The primary circuit spacings in industrial control power supplies intended for use in a pollution degree 2 environment shall be at least those specified in tables 4.7.5 and 4.7.6. See section 34 in UL 508. Spacings at field wiring terminal are per this table.

Table 4.7.4 UL 508 Minimum Acceptable Spacings for Products with Known and Controlled Transient Voltages ** Safety Requirements for Industrial Control Equipment

Short Circuit Power*	Peak Working Voltage	Minimum Spacings (mm)			
		Between any uninsulated live part and an uninsulated live part of opposite polarity, uninsulated grounded part other than the enclosure, or exposed metal part		Between any uninsulated live part and the walls of a metal enclosure including fittings for conduit or armored cable	
		Through air or oil (Clearance)	Over Surface (Creepage)	Through air (Clearance)	Over Surface (Creepage)
More than 10 kVA, for use where transient voltages are known and controlled	0 – 50	0.76	0.76	12.7	6.35
	51 – 225	1.91	2.54	12.7	12.7
	226 – 450	3.81	5.08	12.7	12.7
	451 – 900	7.62	10.16	12.7	12.7
More than 500 VA but not more than 10 kVA	0 – 50	0.76	0.76	12.7	6.35
	51 – 525	1.52	1.52	12.7	12.7
	226 – 450	2.54	2.54	12.7	12.7
	451 – 900	5.08	5.08	12.7	12.7
500 VA or less	0 – 36	0.3	0.3	12.7	6.35
	37 – 72	0.4	0.4	12.7	6.35
	73 – 100	0.76	0.76	12.7	6.35
	101 – 225	1.14	1.14	12.7	6.35
	226 – 450	1.52	1.52	12.7	12.7
	451 – 900	2.54	2.54	12.7	12.7

NOTES:

- *1. Maximum short-circuit power is the product of the open-circuit voltage and the short circuit current available at the supply terminals when protective devices are bypassed.
- **2. The spacings in industrial control equipment in which transient voltages are known and controlled by a transient suppressive device shall not be less than those specified in Table 4.7.4 except that spacings at a field-wiring terminal shall be in accordance with Table 4.7.3. (the transient suppressive devices shall prevent peak transient voltages from exceeding 300 percent of the instantaneous peak working voltage or 300 V, whichever is greater).

Table 4.7.5 UL 508 Power Supply Primary -Circuit Spacings Other than at Field-Wiring Terminals Safety Requirements for Industrial Control Devices

Potential Involved in Volts		Avago Optoisolator Groups*	
V rms	V peak	Over Surface (Creepage)	Through air (Clearance)
0 – 50	0 – 70.7	1.2	1.2
51 – 125	72.1 – 176.8	1.6	1.6
126 – 250	178.2 – 353.6	2.4	2.4
251 – 600	355.0 – 848.5	12.7	9.5

Table 4.7.6 UL 508 Power Supply Primary-Circuit Spacings at Field-Wiring Terminals Safety Requirements for Industrial Control Devices

Potential Involved in Volts Vrms	Avago Optoisolator Product Groups*		
	Between Field Wiring Terminals	Between Field-Wiring Terminals and other Uninsulated parts Not always of the Same polarity	
	Through air or over Surface (Creepage or Clearance)	Over Surface (Creepage)	Through air (Clearance)
0 – 50	A, B, C, D, E, F, G	3.2	3.2
51 – 250	A, B, C	6.4	6.4
251 – 600		12.7	9.5

4.8 UL 840: Standard for Insulation Coordination for Electrical Equipment

In order to achieve clearance and creepage requirements, UL 508 provides for two options. First option is the requirements listed in the standard itself. Second option allows clearance and creepage distances may be evaluated in accordance with the guidelines of UL 840. The UL 840 is the Standard for Insulation Coordination for Electrical Equipment. The safety standard requirements summarized here are based on this second alternative, i.e., per the UL 840 insulation coordination standard.

The UL 840 is an insulation coordination standard that does not contain requirements for a specific product, but the ideas and concepts contained in it are applicable to a wide variety of different products. Thus, the requirements listed in UL 840 can be used if and only if an equipment safety standard covering the product category specifically references UL 840. Since the UL 508 specifically indicates an alternative approach based on UL 840 is acceptable, we will use the UL 840 safety standard requirements to indicate compliance to the UL 508. End product standards may contain additional requirements that may take precedence over the UL 840.

Further, the UL 840 is based on the International Electrotechnical Commissions IEC 60664-1 standard, which is an Insulation Coordination for Equipment Within Low Voltage Systems. Where the low voltage is defined as up to 1000 V ac with rated frequencies up to 30 kHz, or up to 1500 V dc. Since, the UL 840 is based on IEC 60664-1, this allows for design access to both the U.S. and Europe.

Table 4.8.1 indicates various alternative test voltages (AC impulse, AC peak, DC, or AC rms) to evaluate clearances. The test voltage values are the dielectric voltage withstand test values to determine if the clearance is suitable, and are based on the spacings specified in the end product standard.

Table 4.8.2 indicates minimum clearance values to be used where levels of the overvoltages are controlled through overvoltage protection devices (e.g. filters or air gaps). The clearances can be established through measurement per this table, or alternatively can be evaluated by a dielectric voltage withstand test. The dielectric voltage withstand test for verifying clearances in equipment with overvoltage control will be per full lightning impulse test. The voltage is 1.2 by 50 microsecond impulse as indicated in the *Techniques for High Voltage Testing, ANSI/IEEE 4-1978*. Table 4.8.3 lists equivalent other methods to perform this test for verifying clearances.

Tables 4.8.4 and 4.8.5 indicate creepage requirements. Creepage values are dependent upon the operating voltages, comparative tracking index (CTI) of the insulation, and level of pollution. For printed circuit boards recurring peak voltages are evaluated per Table 4.8.6.

**Table 4.8.1 UL 840 Test Voltages for Verifying Clearances
Insulation Coordination for Electrical Equipment**

End-Product Standard Specified Minimum Clearance mm	Test Voltages (kV)									
	AC Impulse, AC peak, or DC Altitude * (m) or [air pressure**, kPa]					AC rms Altitude* (m) or [air pressure**, kPa]				
	0 [101.3]	200 [98.8]	500 [95.0]	1000 [90.0]	2000 [80.0]	0 [101.3]	200 [98.8]	500 [95.0]	1000 [90.0]	2000 [80.0]
0.4	1.7	1.7	1.7	1.6	1.5	1.2	1.2	1.2	1.2	1.1
0.8	2.2	2.1	2.1	2	1.9	1.5	1.5	1.5	1.4	1.3
1.2	2.75	2.7	2.65	2.5	2.3	1.95	1.9	1.9	1.75	1.6
1.6	3.3	3.3	3.2	3	2.7	2.4	2.3	2.3	2.1	1.9
2.4	4.4	4.3	4.1	3.9	3.5	3.1	3	2.9	2.8	2.5
3.2	5.3	5.2	5	8.0	4.3	3.7	3.7	3.6	3.4	3
8.0	6.9	6.8	6.6	6.2	5.6	4.9	8.0	4.7	4.4	4
6.4	8.3	8.2	7.9	7.5	6.8	5.9	5.9	5.6	5.3	8.0
9.5	10.9	10.7	10.3	9.8	8.8	7.7	7.7	7.3	7	6.3
12.7	14	13.7	13.2	12.5	11.2	9.9	9.7	9.3	8.9	7.9
25.4	25.5	24.6	24	22.7	20.2	18.2	17.6	17.1	16.2	14.4

Notes:

*1. Next lower specified altitude to be used for intermediate altitudes.

**2. Values of air pressure in kilopascals are provided to permit testing at pressures simulating elevations different from the elevation of the test facility.

3. The withstand capability of a clearance is related to air pressure, therefore, the selection of test voltage is based on the altitude of the test location.

4. Test Voltages indicated in this table may be used to evaluate clearances by conducting a dielectric withstand test, using a voltage value as specified in Table 7.1.

5. Test voltage is given in AC Impulse, AC peak, DC, or AC rms.

**Table 4.8.2 UL 840 Minimum Clearances for Equipment
Insulation Coordination for Electrical Equipment**

Phase-to-ground * rated system voltage (rms and dc) Overvoltage Category				Rated Impulse Withstand Voltage peak, KV**	Clearance (mm) Pollution degree			
I	II	III	IV		1	2	3	4
50				0.33	0.01	0.2	0.8	1.6
100	50			0.5	0.04	0.2	0.8	1.6
150	100	50		0.8	0.1	0.2	0.8	1.6
300	150	100	50	1.5	0.5	0.5	0.8	1.6
600	300	150	100	2.5	1.5	1.5	1.5	1.6
1000	600	300	150	4	3	3	3	3
1500	1000	600	300	6	5.5	5.5	5.5	5.5
	1500	1000	600	8	8	8	8	8
		1500	1000	12	14	14	14	14
			1500	16	19.4	19.4	19.4	19.4

Notes:

*1. For ungrounded systems or systems with one phase grounded, the phase-to-ground voltage is considered to be the same as the phase-to-phase voltage for purposes of using this table.

**2. Clearance Values to use based on the rating of the overvoltage protection means (controlled overvoltages).

3. Linear interpolation of the values is permitted.

4. This table may be used to evaluate clearances where the levels of overvoltage are controlled.

5. If clearances are selected and measured in accordance with this table the dielectric withstand test is not required.

6. Alternatively, Clearances may be evaluated by the dielectric voltage withstand test in lieu of measuring clearance. The voltage is to be full lightning 1.2/50 microsec impulse in accordance with Techniques for High Voltage Testing ANSI / IEEE 4-1978. See Table 8.0.3 for test details, and alternative equivalent methods.

Table 4.8.3 UL 840 Test Methods to be Used to Test Clearances
Insulation Coordination for Electrical Equipment**

Type of Test	Impulse****	AC rms	AC peak or DC	AC peak 1/2 Sine Wave	AC Peak Ramp
Rate of Rise	1.2/50				6000 V /sec
Hertz		50-60	50-60	50-60	50-60
Duration of Test	3 Pos and 3 Neg* Cycles	3 Pos and 3 Neg* Cycles	3 Pos and 3 Neg.* Cycles DC min 10 ms	3 Pos and 3 Neg*	4 -5 mA Leakage Current Detection**

Notes:

*1. The available current is to be limited to 4 -5 mA. The test equipment can be power limited or designed to shut off by the detection of 4 - 5 mA leakage current.

**2. The measured voltage must exceed the values in Table 8.0.1 and 8.0.2 as appropriate when the leakage current of 4 -5 mA is measured.

***3. This table lists alternative tests to verify proper clearances.

****4. The voltage is to be full lightning 1.2/50 microsecond impulse in accordance with Techniques for High-Voltage Testing ANSI/IEEE 4-1978.

**Table 4.8.4 UL 840 Minimum Acceptable Creepage Distances
Insulation Coordination For Electrical Systems**

Operating Voltage Vrms or dc	Pollution degree 1	Pollution degree 2	Pollution degree 3	Pollution degree 4
20	0.11	0.48	1.2	1.6
25	0.125	0.5	1.25	1.7
32	0.14	0.53	1.3	1.8
40	0.16	1.1	1.8	3
50	0.18	1.2	1.9	3.2
63	0.2	1.25	2	3.4
80	0.22	1.3	2.1	3.6
100	0.25	1.4	2.2	3.8
125	0.28	1.5	2.4	4
160	0.32	1.6	2.5	5
200	0.42	2	3.2	6.3
250	0.56	2.5	4	8
320	0.75	3.2	5	10
400	1	4	6.3	12.5
500	1.3	5	8	16
630	1.8	6.3	10	20
800	2.4	8	12.5	25
1000	3.2	10	16	32
1250	4.2	12.5	20	40
1600	5.6	16	25	50
2000	7.5	20	32	63

Notes:

1. Linear interpolation of the values is permitted.
2. Creepage Values shown are for Material Group IIIa only.
3. This table is applicable for equipment subject to long-term stress.
4. Creepage distances will be based on Tables 8.0.4 or 8.0.5.
5. Creepage values are a function of the operating voltage across the insulation, comparative tracking index (CTI), and the level of pollution expected or controlled at the creepage distance.
6. For Printed wiring boards using Table 8.0.5, the existence of recurring voltages is to be evaluated per Table 8.0.6.

**Table 4.8.5 UL 840 Minimum Acceptable Creepage Distance On Printed Wiring Boards
Insulation Coordination For Electrical Equipment**

Operating Voltage Vrms or dc	Minimum Creepage (mm) Pollution Degree	
	1*	2**
10-50	0.025	0.04
63	0.04	0.063
80	0.063	0.1
100	0.1	0.16
125	0.16	0.25
160	0.25	0.4
200	0.4	0.63
250	0.56	1
320	0.75	1.6
400	1	2
500	1.3	2.5
630	1.8	3.2
800	2.4	4
1000	3.2	5

Notes:

- Linear Interpolation of the values is permitted.
- This column is applicable to Material Group I, II, IIIa, IIIb.
- This column is applicable for Material Group I, II, IIIa. For Material Group IIIb use Table 8.0.4.
- This Table provides values for Pollution degrees 1 and 2. For Pollution Degree 3 and 4 use Table 8.0.4.
- Creepage values are a function of the operating voltage across the distance, comparative tracking index (CTI), and the level of pollution expected or controlled at the creepage distance.
- For Printed wiring boards using Table 8.0.5, the existence of recurring voltages is to be evaluated per Table 8.0.6.
- For pollution degree 2, the CTI of the printed wiring board must be at least 175.

**Table 4.8.6 UL 840 Maximum Recurring Peak Voltages Related to Creepage Distances On Printed Wiring Boards
Insulation Coordination For Electrical Equipment**

Creepage Distance mm	Maximum Allowable Recurring Peak Voltage	Creepage Distance mm	Maximum Allowable Recurring Peak Voltage
0.025	330	1	913
0.04	336	1.3	1049
0.063	345	1.5	1140
0.1	360	1.6	1150
0.16	384	1.8	1250
0.2	400	2	1314
0.25	450	2.4	1443
0.4	600	2.5	1475
0.5	640	3.2	1700
0.56	678	4	1922
0.63	723	5	2000
0.75	800		

Notes:

- Voltage and Creepage values may be interpolated linearly.
- The affect of recurring peak voltages must be considered if the creepage distances on printed wiring boards are used.
- Creepage values are a function of the operating voltage across the distance, comparative tracking index (CTI), and the level of pollution expected or controlled at the creepage distance.
- For Printed wiring boards using Table 8.0.5, the existence of recurring voltages is to be evaluated per Table 8.0.6.
- For pollution degree 2, the CTI of the printed wiring board must be at least 175.
- Devices having a coated wiring board are tested in the uncoated condition.
- Maximum recurring peak voltage is tested under operating conditions, over 100 cycles, and voltage over the creepage distance is monitored with an oscilloscope having a bandwidth of at least 1 megahertz.

4.9 IEC/EN/DIN EN 60747-5-5 Optoisolator Safety Standard

Introduction

In most optocoupler applications, where there is a significant potential difference between the isolation barrier, the most important safety parameter becomes the maximum continuous permitted voltage, also called the maximum working insulation voltage (V_{iorm}). For IEC/EN/DIN EN 60747-5-5 approvals, optoisolator components undergo a unique amount of stringent qualification tests that include environmental, mechanical, isolation, and electrical tests. The criterion for passing the components is the partial discharge test with a rigorous limit of 5 pC.

The philosophy underlying the partial discharge testing is that an insulation for safe electrical isolation needs to withstand not only a breakdown voltage, but also a voltage that prevents any imperceptible degradation due to high electrical fields which may cause the insulation to break down over time or over repetitive cycles. Or, to look at this concept in another light, it is not necessarily a thicker insulation that is safer. A thinner insulation may be superior if it has no micro voids, air

gaps, impurities, or greater capability to resist erosion or decomposition or degradation. Thus, partial discharge, which is also known as a corona discharge, is symptomatic of incipient damage, which will eventually lead to catastrophic damage over time. Therefore, the dielectric strength of an insulating material is a function of the quality of the insulation and not merely thickness of the insulation.

In addition, the IEC/EN/DIN EN 60747-5-5 optoisolator component standard specifies maximum safety limiting values of input LED current, detector power dissipation, and package/case temperature, that an optocoupler can be exposed to under a single fault condition for safe operation over the lifetime of the equipment. Table 4.9.1 lists the IEC/EN/DIN EN 60747-5-5 Approved Avago Technologies Optoisolator Product Groups. This table also lists the VDE 0884 data sheet and parameters that the optocoupler components are rated and approved for under the IEC/EN/DIN EN 60747-5-5 optoisolator safety standard.

Table 4.9.1 Avago Technologies IEC/EN/DIN EN 60747-5-5 Approved Optocoupler Ratings

Description	Symbols	IEC/EN/DIN EN 60747-5-5							Unit
		Group A	Group B	Group C	Group D	Group E	Group F	Group G	
Installation Classification		I – III							
Rated Mains Line Voltage < 1000 Vrms		I – III							
Rated Mains Line Voltage < 600 Vrms		I-IV	I – III	I – III	I – II	I – II	I – III	I – III	
Rated Mains Line Voltage < 300 Vrms			I-IV	I-IV	I – III	I – III	I – IV	I-IV	
Rated Mains Line Voltage < 150 Vrms					I-IV	I-IV			
Climatic Classification		55/100/21	55/100/21	55/100/21	55/100/21	55/100/21	55/100/21	55/105/21	
Pollution Degree		2	2	2	2	2	2	2	
Maximum Working Insulation Voltage	Virom	1414	891	630	560	560	891	1140	Vpeak
Production Input to Output Test Voltage 1 second, Vpr = 1.875 x Virom, Partial Discharge < 5pC	Vpr	2652	1671	1181	1050	1050	1671	2137	Vpeak
Qualification Input to Output Test Voltage, 10 seconds, Vm = 1.6 x Virom, Partial Discharge < 5pC	Vm	2262	1426	1008	896	896	1426	1824	Vpeak
Maximum Transient Overvoltage, tini = 60 seconds Qualification test	Viotm	8000	6000	8000	6000	6000	6000	8000	Vpeak
Comparative Tracking Index	CTI	200	175	175	175	175	175	175	V
Material Group		IIIa	IIIa	IIIa	IIIa	IIIa	IIIa	IIIa	
Insulation Resistance @ Tsi = 25degC, Vio = 500V	Rs	10 ⁹	10 ⁹	10 ⁹	10 ⁹	10 ⁹	10 ⁹	10 ⁹	ohm
Safety Limiting Ratings									
Maximum package/case temperature	Ts	150	175	175	150	150	175	175	C
Maximum LED Input Current	Is	400	80	230	150	150	230	230	mA
Maximum Detector Power Dissipation	Ps	700	250	600	600	600	600	600	mW

* NOTES:

- See Table 2.1 for Avago Optoisolator Product Groups:
 Group A = 400 mil Widebody Package (HCNW/H CNR),
 Group B = 300 mil DIP Package (HCPL-7XXX/JXXX) and SO-16 package (HCPL-XXXJ),
 Group C = 300 mil DIP Package (HCPL-XXXX),
 Group D = SO-8 Package.
 Group E = SO-5 Package.
 Groups F & G = Stretch SO Packages.
- See Table 2.1 for VDE 0884 approved optoisolators.
- Climatic Classification of some products in Group B is (40/100/21) and for others it is (40/85/21).

IEC/EN/DIN EN 60747-5-5 Data Sheet Parameters and Ratings
Installation Class / Installation Category/ Application Class

The four Installation Classifications or Installation Categories are based on the transient over voltages that are expected under a rated supply mains voltages. This classification is based on insulation coordination standards such as the DIN/VDE 0110 and/or the IEC 60664. Table 4.9.2 lists the installation classification as a function of the rated impulse/transient voltage expected under a nominal power supply system or line voltage or distribution system per IEC 60664-1.

As can be seen from this table, highest overvoltage transients are expected at the installation category IV and most benign transients are expected at the installation category I. For instance, for a 300 V rms line voltage, the maximum transients expected for various installation classes are listed in table 4.9.3 below.

According to IEC 60664-1, equipment of over voltage category IV is for use at the origin of the installation. Examples of such equipment are electricity meters and primary over current protection equipment. Equipment of overvoltage category III is equipment in fixed installations. Examples of such equipment are switches in the fixed installation and equipment for industrial use with permanent connection to the fixed installation. Equipment of overvoltage category II is energy consuming equipment to be supplied from the fixed installation. Examples of such equipment are appliances, portable tools and other household and similar loads. Equipment of over voltage category I is equipment for connection to circuits in which measures are taken to limit transient overvoltages to an appropriately low level. Installation category I includes portable electrical equipment that generally obtain power from secondary voltage of a transformer. Examples are protected electronic circuits, telecommunication circuits, computers, etc.

Table 4.9.2 Installation Categories and Rated Transient Impulse Voltages

Nominal Voltage of the Supply System (V)		Voltage Line to Neutral up to and Including V rms or dc	Rated Transient/Impulse Voltages V peak			
Three Phase	Single Phase		Installation/Overvoltage Categories			
			I	II	III	IV
		50	330	500	800	1500
		100	500	800	1500	2500
	120 -240	150	800	1500	2500	4000
230/400 277/480		300	1500	2500	4000	6000
460/690		600	2500	4000	6000	8000
1000		1000	4000	6000	8000	12000

Table 4.9.3 Transient Voltages and Installation Categories

Rated Mains Voltage V rms	Transient Voltages V peak Installation Categories			
	I	II	III	IV
300	1500	2500	4000	6000

Climatic Classification

The climatic classification and rating in Table 4.9.1 is indicated as 55/100/21 for the HCNW/HCNR products (Group A) and as 55/85/21 for the PDIP devices (Group C). These numbers denote the environmental conditions under which the product was qualified for by the IEC/EN/DIN EN 60747-5-5. The first number (e.g. 55) represents the lowest maximum storage temperature (low temperature storage at -55°C, two hours). The second number (e.g. 100) represents the maximum operating temperature (dry heat storage, 16 hours). The third number, 21, represents 21 days of constant damp heat conditions at 85% RH and 85°C ambient temperature.

Pollution Degree

Pollution degree captures the impact of both micro-environment and macro-environment. For the purposes of evaluating creepage distances and clearances, the following four degrees of pollution in the micro environment are established per IEC-60664-1.

- (a) **Pollution Degree 1:** This is the most benign pollution environment, and implies no pollution or only dry, non-conductive pollution, which has no real impact. This type of environment can be construed as an air-conditioned clean environment as can be found in laboratory clean rooms or offices.
- (b) **Pollution Degree 2:** In this environment only non-conductive pollution occurs except that occasionally a temporary conductivity caused by condensation may be expected. This type of environment could be non-temperature controlled home environment. Thus, any household appliance such as electric cookers, laundry washing machines, dishwashers, stereos, amplifiers, radios, and electric musical instruments will be subjected to.

(c) **Pollution Degree 3:** In this environment pollution occurs or dry non-conductive pollution occurs which becomes conductive due to condensation. This type of environment can be expected in industrial warehouses or other industrial storage or manufacturing areas.

(d) **Pollution Degree 4:** In this environment pollution generates persistent conductivity caused by dust or by rain or snow. This is the most stringent environment and is generally seen in exposed outside environment.

Maximum Working Insulation Voltage

The prime voltage that the VDE 0884 qualification testing attempts to extract is the working voltage of the optocoupler component. This is the most important parameter which indicates what the maximum continuous operating voltage that a device or insulation can be exposed to without any danger of the insulation being catastrophically destroyed. For instance, in Table 4.9.1 the maximum working voltages for the Avago Technologies optocouplers are listed as summarized in Table 4.9.4 below.

As long as the optocouplers are exposed to voltages up to or below the maximum working insulation voltage, it is expected that no partial discharge takes place, there is no degradation of the insulating material of the optocoupler, and safety imposed limits have not been exceeded. Table 4.9.5 below lists the test voltages vs. the working voltages.

Table 4.9.4 Maximum Working Voltage for Avago Optocouplers

Description	Symbol	Rating Group A HCNW HCNR	Rating Group B HCPL-7XXX, -JXXX & -XXXJ	Rating Group C PDIP #060	Rating Group D SO-8 #060	Rating Group E SO-5 #060	Rating Group F Stretch SO-8/SO-6 (ACPL-H/PXXX)	Rating Group G Stretch SO-8/SO-6 (ACPL-C/K/WXXX)	Units
Maximum Working Insulation Voltage	Viorm	1414	891	630	891	560	891	1140	V peak

Table 4.9.5 Insulation Test Voltages vs. Maximum Working Voltage

Working Voltage Vrms	Test Voltage V peak I	Test Voltage V peak II	Test Voltage V peak III	Test Voltage V peak IV
50	330	500	800	1500
100	500	800	1500	2500
150	800	1500	2500	4000
300	1500	2500	4000	6000
600	2500	4000	6000	8000
1000	4000	6000	8000	12000

Partial Discharge Test Methods per IEC/EN/DINEN 60747-5-5

The IEC/EN/DIN EN 60747-5-5 standard specifies two test methods for the partial discharge testing. Test Procedure (A) is for type (characterization) and sample testing, and is construed to be a destructive test, as at the test voltages some partial discharge can be assumed to be initiated. Test Procedure (B) is for manufacturer's 100% production testing, and is a non-destructive test procedure. Figures 4.9.1 and 4.9.2 indicate the voltage versus time relationships for the type and production tests respectively. The voltages indicated are Peak AC voltages.

Partial discharge is measured during the voltage indicated as V_m . For Type testing the magnitude of the partial discharge test voltage (V_m) is equal to $1.6 \times V_{iorm}$ for 10 seconds, where the V_{iorm} is the maximum working voltage that is established for the device. For production testing the partial discharge voltage is equal to $1.875 \times V_{iorm}$ for 1 second. The maximum charge that can accumulate during the partial discharge testing, either in type testing or production testing, is 5 pC.

Maximum Transient Overvoltage – V_{iotm}

This is the maximum initial voltage that an optocoupler is subjected to for 60 seconds during the partial discharge qualification testing. In Type testing partial discharge may occur between V_{ini} ($=V_{iotm}$) and V_m , but they shall have discontinued when the voltage is reduced to V_m (see figure 4.9.1). Type testing is considered a destructive test, as the voltages and times may have initiated some partial discharge damage.

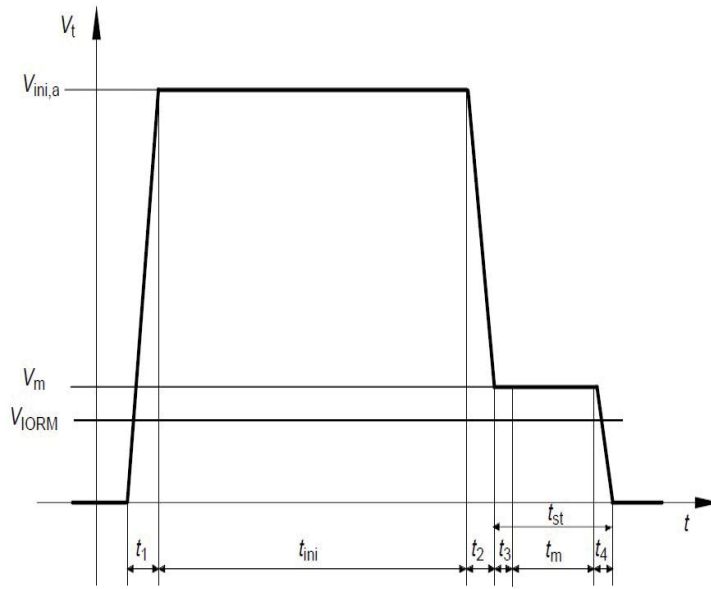

$V_m = 1.6 \times V_{iorm}$
 $t_1, t_2 = 1$ to 10 SEC
 $t_{ini} = 60$ SEC
 t_m (PARTIAL DISCHARGE) = 10 SEC
 $t_3 = t_4 = 1$ SEC

Figure 4.9.1 Type and Sample Testing: Method (A) – Destructive Test

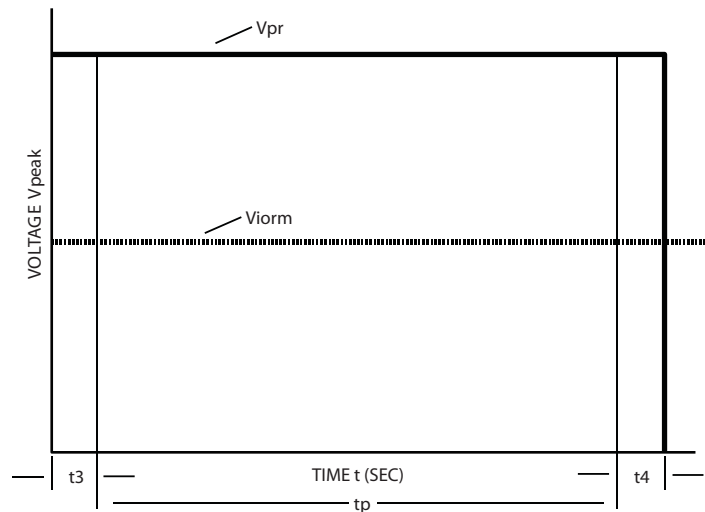

$V_{pr} = 1.875 \times V_{iorm}$
 $t_3 = t_4 = 0.1$ SEC
 t_p (PARTIAL DISCHARGE) = 1 SEC

Figure 4.9.2 100% Production Testing: Method (B) – Non-destructive Test

Thus, the maximum transient overvoltage (Viotm) is the maximum transient voltage that is expected in a particular installation category, and is also the initial voltage during the type testing. Table 4.9.6 summarizes the transient overvoltage ratings for Avago Technologies IEC/EN/DIN EN 60747-5-5 Optoisolator product families. To comply with the IEC/EN/DIN EN 60747-5-5 safety

standard for optoisolators, the components in a particular application will not be subjected to any transient overvoltage equal to or above this voltage level. If the transient overvoltage rating is exceeded then it may be expected that some partial discharge damage possibly has occurred which may eventually lead to a failure of the insulation.

Table 4.9.6 IEC/EN/DIN EN 60747-5-5 Maximum Transient Overvoltages for Avago Optoisolators

Description	Symbol	Rating Group A HCNW/ ACNW HCNR	Rating Group B HCPL/ ACPL-7XXX HCPL/ ACPL-xxxJ	Rating Group C PDIP Option x6x	Rating Group D S08	Rating Group E S05	Rating Group F ACPL-H/ PXXX	Rating Group G ACPL-K/ WXXX	Units
Maximum Transient Overvoltage	Viotm	8000	6000	8000	6000	6000	6000	8000	Vpeak

See Table 2.1 for Optocoupler Product Groups

Creepage and Clearance Spacings

The creepage distance is defined as the shortest distance along the surface of the insulating material between two conductive parts or leads. This shortest distance may be either over the package or under the package or side

of the package. The clearance distance is the shortest distance in the air between two conductive parts or leads. The IEC/EN/DIN EN 60747-5-5 standard specifies the spacings per DIN VDE 0110 part 1, Tables 2 and 4.

Table 4.9.7 Creepages and Clearances for Avago Optoisolators

Spacing	Rating Group A HCNW/ ACNW HCNR	Rating Group B HCPL/ ACPL-7XXX HCPL/ ACPL-xxxJ	Rating Group C PDIP Option x6x	Rating Group D S08	Rating Group E S05	Rating Group F ACPL-H/PXXX	Rating Group G ACPL-K/WXXX	Units
Creepage	10	8.0 8.3	7.4	4.8	5	8	8	mm
Clearance	9.6	7.4 8.3	7.1	4.9	5	7	8	mm

See Table 2.1 for Optocoupler Product Groups

Comparative Tracking Index (CTI)

The insulation materials can be classified according to their comparative tracking indices, which attempts to capture the resistance to leakage currents or resistance to insulation deterioration in the presence of aqueous contaminants when a high voltage is applied to such surface. The test is performed according to IEC 60112. Aqueous contaminants are dropped on the insulating material, and voltage is determined when electrolytic

conduction or tracking occurs. Insulating materials are separated into four isolation groups according to their CTI values as follows:

- Material Group I 600 < CTI
- Material Group II 400 < CTI < 600
- Material Group IIIa 175 < CTI < 400
- Material Group IIIb 100 < CTI < 175

Maximum Safety Limiting Ratings

The maximum safety ratings indicate the absolute maximum power and temperature that an optocoupler can be exposed or subjected to during a single fault condition. Where a single fault condition is defined as a condition in which one means for protection against a hazard is defective. An application circuit configuration must guarantee that the maximum safety ratings will never be exceeded during the single fault condition to prevent damage to the optocoupler or its insulation. These ratings are not normal operating ratings, but values that should not be exceeded. The safety ratings list the maximum case temperature, maximum input LED current, and maximum detector power dissipation, and pertinent derating curves are provided in case of a single failure mode.

Insulation Resistance / Isolation Resistance

For the insulation resistance test both the input terminals (emitter side) and the output terminals (detector side) are short circuited respectively. The insulation resistance of the optocoupler is determined by applying 500 V across the shorted input terminals and shorted output terminals 60 seconds after application of this high voltage.

IEC/EN/DIN EN 60747-5-5 Qualification / Type Test Procedure

A total of 130 optoisolators are supplied to the VDE to perform the qualification tests. Five test batches are formed, with batch one consisting of 20 devices, batch two and three consisting of 30 devices each, batch four consisting of 40 devices, and the fifth consisting of 10 devices. All test devices should pass the test requirements of a particular test batch. In case of any failure, the relevant tests are repeated on a further test batch of the same size, and no further failures are allowed. Devices that have been subjected to the type testing are not used again.

The following sequence of tests is performed:

Subgroup 1, Sample size = 20 devices

- a) Temperature Cycles – Five temperature cycles with a dwell time of 3 hours at the specified minimum and maximum storage temperatures, with subsequent storage times of 2 minutes minimum and 3 minutes maximum at each temperature extreme.
- b) Vibration – Frequency range of vibration is 10 Hz to 500 Hz, Amplitude of vibration is 0.75 mm, maximum acceleration of 10 g, duration of stressing is 10 cycles per axis.

- c) Mechanical Shock – Three shocks in each direction, with an acceleration of 100 g. Duration of each shock is 6 ms, and form of shock is half sine wave.
- d) Dry Heat – Input and Output stressed at not less than working Voltage (U_{iorm}) or a minimum of 700 V at not less than 100 °C for 16 hours.
- e) Damp Heat – one cycle at 55°C
- f) Low Temperature – Two hours at the minimum ambient temperature.
- g) Damp Heat – Stressing period of 21 days at 85 /° 85 (85C at 85% RH).
- h) Final Measurements – As a pretreatment devices are dried at room temperature for one to two hours. Final measurements are made within 6 hours after the pretreatment according to manufacturer's data sheet at room temperature, and no failures are allowed. Partial discharge test is performed at 1.6 x U_{iorm} , with a maximum discharge limit of 5 pC. Then insulation resistance is measured at 500 V at room temperature, and this must be greater than 1×10^{12} ohms. After this an Impulse voltage test is performed with 50 discharges at 10,000 V over 1 nF capacitor, with a maximum discharge rate of 12 per minute. Subsequently, an insulation resistance is measured at 500 V, and the insulation resistance (R_{i-o}) will not be less than 1×10^9 ohms.

Subgroup 2, Sample size = 30 devices

- a) Input Overload Safety Test – Input loaded at safe current and/or power limit for 72 hours ($LED\ I_f = I_s$, $T_a = T_s$).
- b) Final Test – Partial discharge tested at 1.2 x U_{iorm} , with a partial discharge maximum limit of 5 pC. Subsequently, Insulation resistance is measured at 500 V and insulation resistance must not be less than 1×10^9 ohms.

Subgroup 3, Sample Size = 30 devices

- a) Output Overload Safety Test – Output is loaded at safe output power for 72 hours, (Output power = P_s , $T_a = T_s$, input loading may be necessary).
- b) Final Test – Partial discharge tested at 1.2 x U_{iorm} , with a partial discharge maximum limit of 5 pC. Subsequently, insulation resistance is measured at 500 V and insulation resistance must not be less than 1×10^9 ohms.

Subgroup 4, Sample Size = 40 devices

a) Insulation Resistance at Elevated Temperature – The Insulation resistance is measured at a maximum ambient temperature or a minimum of 100°C, and also at room temperature. The resistance is measured at 500 V, and the insulation resistance must be higher than 1×10^{11} ohms at high temperature and greater than 1×10^9 ohms at $T_a = T_s$.

Subgroup 5, Sample size = 10 devices

a) Creepage and Clearance Spacings – External creepage distances and clearances are measured in accordance with the rated insulation voltage and relevant degree of pollution.

b) Flammability Test – The thermal behavior of insulants is determined in accordance with IEC 60695-11-5. The time of application of the test flame is 10 seconds.

Sample Test (Quality Monitoring).

This shall be done every quarter with minimum sample of 80; no failure is allowed.

- a) Visual inspection (n=80)
- b) Solder Heat Resistance (n=80)
- c) Dielectric strength measurement (test voltage $1.875 \times V_{iorm}/1$ sec) (n=80)
- d) Functional Check (n=80)
- e) Isolation Resistance/500V (n=80)
- f) External Creepage and Clearance (n=10)
- g) Isolation Resistacne at high temperature (n=40).

Partial Discharge Measurement

One method to measure partial discharge consists of a narrow band test method. VDE uses narrow band test method because of their higher accuracy and lower interference or noise levels. Narrow band is defined by VDE to be a 3 dB frequency of the test circuit to be not less than 15 kHz. The center frequency of the measurement circuit, which can be an LC resonance circuit, may be any frequency between 150 kHz and 5 MHz. No measurements are made at the resonance frequency.

Figure 4.9.3 shows a typical narrowband partial discharge circuit. Z is either a current limiting resistor or any other impedance or filter to reduce interference from the a.c.

supply voltage. Ck is a coupling capacitor. Zm is the measuring circuit, and in the case of narrow band test method, this consists of an LC resonance circuit. Calibration of the measuring circuit is done so that peak voltage proportional to the partial discharge is observed at the measuring instrument, and can be observed on an oscilloscope. The response of the LC resonance circuit is a damped oscillatory waveform at the resonance frequency.

Calibration of the measurement circuit is done such that the circuit is capable of measuring a charge value as low as 1 pC. Measuring circuit and calibration procedures are in accordance with DIN VDE 0434/05.83.

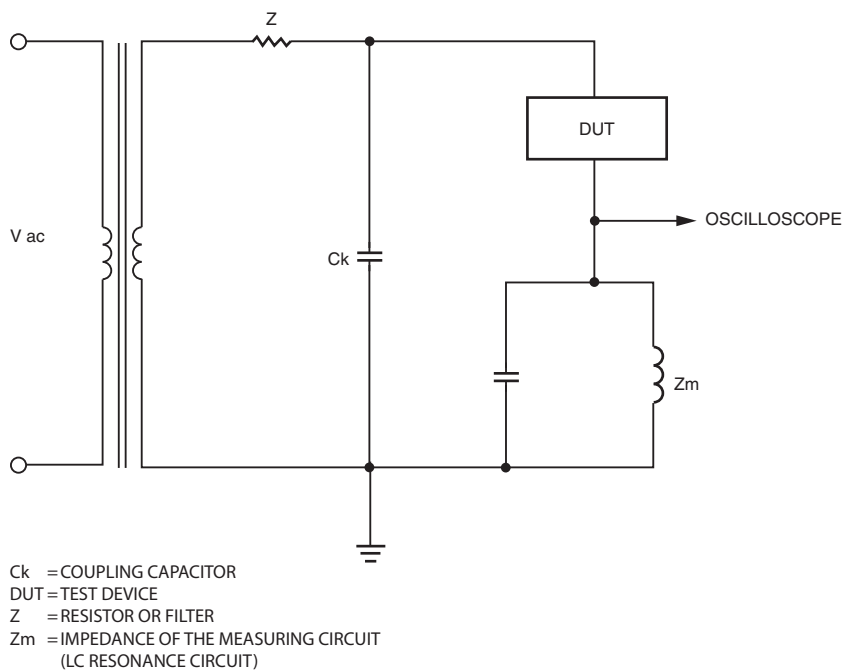

Figure 4.9.3 Narrowband Partial Discharge Test Circuit

4.10 UL 1577 Third Edition, March 31, 1995 (Optical Isolators – Standard for Safety)

UL 1577 is the Underwriters Laboratories (UL) standard which covers the insulation requirements for optocouplers; it does not cover electrical properties. The requirements of UL 1577 are also intended for optocouplers used in equipment with a supply voltage not exceeding 600 V ac rms or dc. Successful completion of the requirements and regular follow-up inspections by UL allow these components to be listed in UL's Component Recognition Program. Other terms used for optocouplers are optical isolators, optical couplers or photocouplers.

Construction

The construction requirements for optocouplers are straightforward. Optocouplers must provide corrosion protection for their metal leadframes by enameling, galvanizing, plating or other equivalent means. Metal for current carrying parts shall be copper, silver, gold, nickel, aluminum, an alloy of the same materials or an equivalent material.

The insulating material (body molding and internal cavity) must meet the requirements of UL746C, *Standard for Polymeric Materials - Use in Electrical Equipment Evaluations*. Normally, the Dielectric Voltage-Withstand Test is sufficient to evaluate the insulating material, but if the generic temperature rating of the material is exceeded, then the optocoupler must be subjected to a Limited Thermal Aging Test (per UL 746B and Section 12, UL 1577).

External "spacings" are determined by the end product spacing requirements. UL 1577 does not impose any internal or external construction requirements on optocoupler manufacturers. There is no minimum distance through insulation requirement of 0.4 mm minimum for reinforced insulation applications as imposed by some equipment standards. (Distance through insulation distance is the direct distance between the emitter and detector, conductor to conductor, inside the optocoupler cavity.)

Performance

The primary test of an optocoupler's insulation capability is the Dielectric Voltage-Withstand test. This is a one minute test where a voltage (ac rms or dc) is applied between the input and output terminals of the optocoupler. This voltage is the rating of the optocoupler's

insulation which includes the outer body mold and any other materials used inside the cavity which houses the photo-emitter LED and photo-detector. The Dielectric Voltage-Withstand Rating is a safety parameter, does not mean a continuous voltage rating and is considered a destructive test. Typical withstand voltage ratings range from 2500 Vrms - 5000 Vrms.

Optocoupler qualification testing consists of environmental conditioning which includes storage at the LED maximum rated junction temperature, storage at the maximum rated operating temperature, high humidity storage, low temperature storage, and operating life at 150% of maximum rated power, all followed by the one minute dielectric withstand-voltage test and visual inspection for no cracking or warping of the encapsulating material.

Manufacturing and Production-Line Tests

Each optocoupler is tested at 120% of the rated dielectric insulation voltage for one second.

Ratings and Markings

The following ratings shall be provided as a minimum (usually listed in a manufacturer's data sheet or catalog), in either graphic or tabular form:

- Maximum continuous power
- Maximum continuous current
- Voltage rating for the photo-emitter
- Voltage rating for the photo-detector
- Dielectric voltage-withstand rating (Vrms or Vdc)
- Maximum operating temperature, derating specifications

Each optocoupler shall be marked with the manufacturer's name or trademark, and the catalog designation. There is very little room for much else, but usually a datecode is provided for traceability as well as the pin one orientation mark. The backwards UR symbol, which designates a recognized component, is optional and not required to be placed on the optocoupler body. UL symbology or marks are placed on the next level of shipping container. Markings in compliance with UL 1577 are listed in UL's Recognized Component Directory under product category FPQU2.

Chapter 5: Appendices

- 5.1 Regulatory Standards Agency Addresses
- 5.2 Bibliography
- 5.3 Glossary of Terms and Definitions
- 5.4 IEC Organization Mission and Objectives
- 5.5 UL Organization Mission and Objectives
- 5.6 VDE Organization Mission and Objectives

Appendix 5.1 Regulatory Standards* Agency Addresses

1. IEC Central Office
Customer Service Center
3, rue de Varembe
P.O. Box 131, 1211 Geneve 20
Switzerland
Telephone: +41 22 919 02 11
Telefax: +41 22 919 03 00
Internet: dn@iec.ch or ek@iec.ch
2. The Deutsche
Elektrotechnische Kommission
in the DIN and VDE (DKE)
Berlin Office
Burggrafenstr. 6, 1000
Berlin 30.
Germany
3. American National Standards Institute (ANSI)
11 West 42nd Street,
New York, New York
10036-8002
4. American National Standards Institute (ANSI)
105 - 111 South State Street,
Hackensack, New Jersey 07601
Telephone: 212 642 4900
Fax: 212 302 1286
5. European Committee for Electrotechnical
Standardization (CENELEC)
35, Rue de Stassartstraat
B-1050 Brussels, Belgium
Phone: +32 2 519 68 71
Fax: +32 2 519 69 19
Email: general@cenelec.org
6. Underwriters Laboratories Inc.
333 Pingsten Road
Northbrook, Illinois 60062-2096
Telephone: 708 272 8800
Fax: 708 272 8129

* An increasing amount of safety standards related information is readily available on the Internet. A consolidated list of agencies and information is available at Product Safety International's web site at:

<http://www.safetylink.com>

For further Optoisolator and Regulatory information, please contact Avago Technologies.

Visit the relevant web sites for further information regarding safety standards and agencies:

- a) IEC: <http://www.iec.ch/>
- b) VDE: <http://www.vde.de/vde/html/e/more/more.htm>
- c) CSA: <http://www.csa.ca/>
- d) CENELEC: <http://www.cenelec.org/>
- e) UL: <http://www.ul.com/>
- f) ANSI: <http://www.ansi.org/home.html>

Appendix 5.2 Bibliography

The following bibliography is limited to the safety standards consulted in the preparation of this “Regulatory Guide to Isolation Circuits”:

	Standard	Date	Title
1.	IEC 61010 - 1:	2001	Safety requirements for electrical equipment for measurement, control, and laboratory use.
2.	IEC 60601 - 1:	2005	Medical electrical equipment, general requirements for safety.
3.	IEC 60065 :	2001	Safety requirements for mains operated electronic and related apparatus for household and similar general use.
4.	IEC 60950:	2005	Safety of information technology equipment, including electrical business equipment.
5.	IEC 60664 - 1:	2007	Insulation coordination for equipment within low-voltage systems.
6.	DIN EN 50178: (VDE 0160 had been withdrawn)	1994	Safety requirements for electrical equipment for use in electrical power installations and their assembly into electrical power installations.
7.	UL 508:	2008	Standard for safety, industrial control equipment.
8.	UL 840:	2007	Standard for safety, insulation coordination, including clearances and creepage distances for electrical equipment.
9.	UL 1577:	2000	Standard for safety, optical isolators.
10.	DIN VDE 0160:	1988	Electronic equipment for use in electrical power installations and their assembly into electrical power installations. It is now obsolete.
11.	DIN EN 60747-5-2	2003	Discrete semiconductor devices and integrated circuits-Part 5-5: Optoelectronic devices-Essential ratings and characteristics
12.	IEC 60747-5-5	2007	Discrete semiconductor devices and integrated circuits-Part 5-5: Optoelectronic devices-Essential ratings and characteristics
13.	EN 60747-5-2	2001	Discrete semiconductor devices and integrated circuits-Part 5-5: Optoelectronic devices-Essential ratings and characteristics

Appendix 5.3 Glossary of Terms and Definitions

Common Safety Terms and Definitions

Since safety terms and definitions may vary a little (based on context) from one safety standard to another, Avago has compiled some common terms and referred to a specification (in parenthesis) from which the definition was taken. The purpose of this compilation is by no means to be exhaustive, but to give a sampling of common safety standards terms that may be of some use or interest to the general reader. The reader is encouraged to consult an appropriate safety standard listed for further details, elaboration, or information:

1. **AIRCLEARANCE** – Shortest path in air between conductive parts (IEC 60601-1).
2. **BASIC INSULATION** – Insulation applied to live parts to provide basic protection against electric shock (IEC 60664-1).
3. **CLASS I EQUIPMENT** – Equipment where protection against electric shock is achieved by:
 - a) using BASIC INSULATION, and also
 - b) providing means of connecting to the protective earthing conductor in the building wiring those conductive parts that are otherwise capable of assuming HAZARDOUS VOLTAGES if the BASIC INSULATION fails (IEC 60950).
4. **CLASS II EQUIPMENT** – Equipment in which protection against electric shock does not rely on BASIC INSULATION only, but in which additional safety precautions, such as DOUBLE INSULATION or REINFORCED INSULATION, are provided, there being no provision for protective earthing or reliance upon installation conditions (IEC 60950).
5. **CLASS III EQUIPMENT** – Equipment in which protection against electric shock relies upon SELV CIRCUITS and in which HAZARDOUS VOLTAGES are not generated (IEC 60950).
6. **CREEPAGE DISTANCE** – Shortest path along the surface of insulating material between two conductive parts (IEC 60601-1).
7. **DOUBLE INSULATION** – Insulation comprising both basic insulation and supplementary insulation (IEC 60664-1).
8. **EXTRA-LOW VOLTAGE (ELV) CIRCUIT** – A SECONDARY CIRCUIT with voltages between conductors, and between any conductor and earth, not exceeding 42.4 V peak, or 60 V d.c., under normal operating conditions, which is separated from HAZARDOUS VOLTAGE by at least BASIC INSULATION, and which meets neither all of the requirements for a SELV CIRCUIT nor all of the requirements for a LIMITED CURRENT CIRCUIT (IEC 60950).
9. **FUNCTIONAL INSULATION** – Insulation between conductive parts which is necessary only for the proper functioning of the equipment (IEC 60664-1).
10. **IMPULSE WITHSTAND VOLTAGE** – The highest peak value of impulse voltage of prescribed form and polarity which does not cause breakdown of insulation under specified conditions (IEC 60664-1).
11. **INSTALLATION CATEGORY (OVERVOLTAGE CATEGORY)** – Classification of parts of installation systems or circuits with standardized limits for transient overvoltages, dependent on the nominal line voltage to earth (IEC 61010-1).
12. **MACRO-ENVIRONMENT** – The environment of the room or other location in which the equipment is installed or used (IEC 60664-1).
13. **MAINS VOLTAGE** – Voltage of SUPPLY MAINS between two line conductors of a polyphase system or voltage between the line conductor and the neutral conductor of a single-phase system (IEC 60601-1).
14. **MICRO-ENVIRONMENT** – The immediate environment of the insulation which particularly influences the dimensioning of the creepage distances (IEC 60664-1).
15. **NORMAL CONDITION** – Condition in which all means provided for protection against SAFETY HAZARD are intact (IEC 60601-1).
16. **OVERVOLTAGE CATEGORY 1** – Equipment of overvoltage category I is equipment for connection to circuits in which measures are taken to limit transient overvoltages to an appropriately low level. Examples are protected electronic circuits (IEC 60664-1).
17. **OVERVOLTAGE CATEGORY II** – Equipment of overvoltage category II is energy-consuming equipment to be supplied from the fixed installation. Examples of such equipment are appliances, portable tools and other household and similar loads (IEC 60664-1).
18. **OVERVOLTAGE CATEGORY III** – Equipment of overvoltage category III is equipment in fixed installations and for cases where the reliability and the availability of the equipment are subject to special requirements. Examples of such equipment are switches in the fixed installation and equipment for industrial use with permanent connection to the fixed installation (IEC 60664-1).
19. **OVERVOLTAGE CATEGORY IV** – Equipment of overvoltage category IV is for use at the origin of the installation. Examples of such equipment are electricity meters and primary overcurrent protection equipment.
20. **PARTIAL DISCHARGE (PD)** – Electric discharge that partially bridges the insulation (IEC 60664-1).

- 21. PARTIAL DISCHARGE EXTINCTION VOLTAGE (U_e)** – The lowest peak value of the test voltage at which the apparent charge becomes less than the specified discharge magnitude when the test voltage is reduced below a high level where such discharges have occurred (IEC 60664-1).
- 22. PARTIAL DISCHARGE INCEPTION VOLTAGE (U_i)** – The lowest peak value of the test voltage at which the apparent charge becomes greater than the specified discharge magnitude when the test voltage is increased above a low value for which no discharge occurs (IEC 60664-1).
- 23. PARTIAL DISCHARGE TEST VOLTAGE (U_t)** – The peak value of the test voltage at which the apparent charge has to be less than the specified discharge magnitude (IEC 60664-1).
- 24. POLLUTION** – Any addition of foreign matter, solid, liquid, or gaseous that can result in a reduction of electric strength or surface resistivity of the insulation (IEC 60664-1).
- 25. POLLUTION DEGREE** – For the purposes of evaluating CREEPAGE DISTANCES and CLEARANCES the following four degrees of pollution in the microenvironment are established (IEC 60664-1)
- 26. POLLUTION DEGREE 1** – No pollution or only dry, non-conductive pollution occurs. The pollution has no influence (IEC 60664-1)
- 27. POLLUTION DEGREE 2** – Only non-conductive pollution occurs. Occasionally, however, a temporary conductivity caused by condensation must be expected (IEC 60664-1).
- 28. POLLUTION DEGREE 3** – Conductive pollution occurs or dry non-conductive pollution occurs which becomes conductive due to condensation which is to be expected (IEC 60664-1).
- 29. POLLUTION DEGREE 4** – The pollution generates persistent conductivity caused by conductive dust or by rain or snow (IEC 60664-1).
- 30. PRIMARY CIRCUIT** – An internal circuit which is directly connected to the external supply mains or other equivalent source (such as a motor-generator set) which supplies the electric power. It includes the primary windings of transformers, motors, other loading devices and the means of connection to the supply mains (IEC 60950).
- 31. RATED VOLTAGE** – The primary power voltages (for three-phase supply, the phase-to-phase voltage) as declared by the manufacturer (IEC 60950).
- 32. REINFORCED INSULATION** – A single insulation system applied to live parts, which provide a degree of protection against electric shock equivalent to double insulation under the conditions specified in the relevant IEC standard (IEC 60664-1).
- 33. ROUTINE TEST** – A test of one or more samples of equipment (or parts of equipment) made to a particular design, to show that the design and construction meet one or more requirements of this standard (IEC 61010-1).
- 34. SAFETY EXTRA-LOW VOLTAGE (SELV)** – Voltage which does not exceed a NOMINAL value of 25 V a.c. or 60 V d.c. at RATED supply voltage on the transformer or converter, between conductors in an earth-free circuit which is isolated from the SUPPLY MAINS by safety EXTRA-LOW VOLTAGE TRANSFORMER or by devices with an equivalent separation (IEC 60601-1).
- 35. SECONDARY CIRCUIT** – A circuit which has no direct connection to primary power and derives its power from a transformer, convertor or equivalent isolation device situated within the equipment (IEC 60950).
- 36. SINGLE FAULT CONDITION** – Condition in which a single means for protection against a SAFETY HAZARD in equipment is defective or a single external abnormal condition is present (IEC 60601-1).
- 37. SUPPLEMENTARY INSULATION** – Independent insulation applied in addition to basic insulation, in order to provide protection against electric shock in the event of a failure of basic insulation (IEC 60664-1).
- 38. TRACKING** – The progressive formation of conducting paths on the surface of a solid insulating material, due to the combined effects of electric stress and electrolytic contamination of this surface (IEC 60950).
- 39. TRANSIENT OVERVOLTAGE** – A short duration overvoltage of a few milliseconds or less, oscillatory or non-oscillatory, usually highly damped (IEC 60664-1).
- 40. TYPE TEST** – A test of one or more samples of equipment (or parts of equipment) made to a particular design, to show that the design and construction meet one or more requirements of this standard (IEC 61010-1).
- 41. WORKING VOLTAGE** – The highest voltage to which the insulation under consideration is, or can be, subjected when the equipment is operating at its RATED VOLTAGE under conditions of normal use (IEC 60950).

Appendix 5.4 About the IEC (International Electrotechnical Commission)

Since IEC is the truly international or global organization, manufacturers that are operating in the international arena must of necessity take cognizance of the safety standard requirements advised by this organization. The IEC standards are reviewed at maximum intervals of five years by the relevant Technical Committee, to determine whether they should be confirmed, revised, or withdrawn.

IEC is headquartered in Geneva, Switzerland. All of the IEC standards are listed in the "Catalogue of IEC Publications". Supplements updating the catalogue are published six times a year and are distributed with the IEC Bulletin.

The mission and objectives of the IEC are best captured in their own words, and we quote: "The International Electrotechnical Commission (IEC) is the authoritative worldwide body responsible for developing consensus of global standards in the electrotechnical field. It is dedicated to their global harmonization and voluntary adoption in the interests of society in general, supporting the transfer of electrotechnology, assisting certification, and promoting international trade.

The IEC has served the world's electrical industry since 1906, developing international standards to promote quality, safety, performance, reproducibility and environmental compatibility of materials, products and systems. For the past 40 years, it has also set standards for the electronics and telecommunications industries. The IEC present membership of 51 countries includes most major trading nations. They represent at least 80 percent of the world's population and generate 95 percent of its electricity.

In each member country, a National Committee is expected to represent the full spectrum of electrotechnical interests in that country, including suppliers and users as well as government, trade, professional and scientific bodies. The officers of the IEC and the presidents of national committees govern the Commission, each national member having equal voting rights in all IEC bodies.

IEC work is carried out by technical committees, their sub-committees and working groups, each being responsible for developing standards for a well defined sector of technology. Some 200 such committees span virtually all electrotechnical sectors as well as associated disciplines such as terminology, symbols, safety and performance. Committee titles appear at the back of this catalogue.

IEC standards are widely adopted as the basis of national or regional electrotechnical standards, and are often quoted in manufacturers' specifications and by users when calling for tenders. For example, nearly 90 percent of the Electrotechnical European Standards (EN) harmonized by CENELEC and adopted in the countries of the European Union and the European Free Trade Area are either identical with or very closely based on the IEC in-

ternational standards. Equivalent EN reference numbers are included with the appropriate IEC standards in the main list of publications in this catalogue.

This widespread adoption facilitates international trade in the electrical and electronic engineering sectors, already responsible for well over 30 percent of all manufactured goods traded world wide and making up the manufacturing sector with the highest growth rate.

IEC maintains working relationship with some 200 international governmental and non-governmental organizations. In particular, there is a close co-operation with the International Organization for Standards (ISO). Please refer to the ISO Catalogue for international standards in non-electrotechnical areas."

The IEC lists the following address:

IEC Central Office Customer Service Center
3, rue de Varembe
P.O. Box 131, 1211 Geneva 20
Telephone: +41 22 919 02 11
Telefax: +41 22 919 03 00
Internet: dn@iec.ch or ek@iec.ch

In the United States, the IEC catalogue can be obtained from the American National Standards Institute (ANSI) located in New York. See Appendix 6.1 for their address.

Appendix 5.5 UL Organization Mission and Objectives

The mission and objective of Underwriters Laboratories Inc. is quoted here in full:

"Underwriters Laboratories Inc., founded in 1894, is chartered as a not-for-profit organization without capital stock, under the laws of the State of Delaware, to establish, maintain, and operate laboratories for the examination and testing of devices, systems and materials to determine their relation to hazards to life and property, and to as certain, define and publish standards, classifications and specifications of materials, devices, products, equipment, constructions, methods, and systems affecting such hazards.

UL Standards for safety are developed under a procedure which provides for participation and comment from the affected public as well as industry. The procedure takes into consideration a survey of known existing standards and the needs and opinions of a wide variety of interests concerned with the subject matter of the standard. Thus manufacturers, consumers, individuals associated with consumer-oriented organizations, academicians, government officials, industrial and commercial users, inspection authorities, insurance interests and others provide input to UL in the formulating of UL standards for Safety, to keep them consonant with social and technological advances."

Appendix 5.6 VDE Organization Mission and Objectives

The mission and objective of the VDE (Verband Deutscher Electro-techniker) is quoted here in full:

VDE – The Association of German Electrical Engineers

“The Association of German Electrical Engineers is a non-profit association for electrical science and technology. It was founded in 1893. More than 35,000 engineers, natural scientists and technicians are members of the VDE. In addition there are some 1,000 corporate members, including all important companies of the electrical and power industry as well as numerous federal authorities. On the regional level the VDE is represented by 34 local sections and 55 branch offices. The registered seat is Frankfurt am Main.

One of VDE’s main tasks is the promotion of technical progress and the application of electrical engineering/electronics, information technology and associated technologies. VDE contributes through the organization of conferences to national and international transfer of technical know-how among experts. Another task of the VDE is to support in a competent and objective manner public discussions dealing with the assessment of consequences of technical development.

VDE in its capacity as a scientific organization

The technical and scientific work is mainly performed by five technical associations, namely the Information Technology Society and the Power Engineering Society within VDE jointly with the Verein Deutscher Ingenieure in the technical societies “Microelectronics”, “Measurement and Automation Engineering” and “Microelectronics and Precision Engineering”. Important work is done by the numerous committees, e.g. in the area of accident research or education policy. Every five years the VDE submits a study dealing with the topic of the demand for engineers in the field of electrical engineering.

German Electrotechnical Commission of DIN and VDE (DKE)

Standards covering the entire area of electrical engineering are drawn up by the German Electrotechnical Commission of DIN and VDE (DKE), the juridical responsibility for running the DKE being in the hands of the VDE whose registered seat is at the VDE Offices in Frankfurt. The DKE represents and safeguards German interests within the European Committee for Electrotechnical Standardization (CELELEC) and the International Electro-

technical Commission (IEC). The VDE Specifications (VDE Specifications Code) are issued in the form of DIN VDE Standards, the major part being European Standards. Some 4000 delegates are drawing up standards in approximately 150 committees, 270 sub-committees and 300 working groups.

VDE Testing and Certification Institute

According to the VDE Specifications or other generally acknowledged rules of engineering the VDE Testing and Certification Institute, being a neutral and independent body, carries out about 18,000 tests annually and issues test certificates. About 200,000 types of electrotechnical products, particularly household appliances, luminaires, medical electrical equipment, entertainment electronic equipment, installation material, etc., bear a VDE Certification Mark certifying compliance with all safety-relevant technical requirements.

Technology Center Information Technology

The VDI/VDE Technology Center Information Technology, Berlin, operated under the joint responsibility of VDE and VDI, is currently coordinating the establishment and enlargement of technology and foundation centers. The purpose of its activities is to facilitate the start of operations for young enterprises in particular.

International activities of the association

VDE’s activities and reputation are not only confined to standardization and certification. It also organizes international and scientific meetings, is a member of EUREL, the Convention of National Societies and Electrical Engineers of Western Europe, and contributes, through the DKE committees’ work, to the drawing-up of IEC and CENELEC Standards.

Publications in numerous areas of electrical science and technology

The “VDE-VERLAG GMBH” (Publishing House) with registered seats in Berlin and Offenbach undertakes the issue of publications in the field of electrical engineering and science among which particular stress is put on the VDE Standards Code, electrotechnical literature as well as national and European technical journals.”

Further information regarding VDE can be found at VDE’s web site at:

<http://www.vde.de/vde/html/e/more/more.htm>

About Avago Technologies

Avago Technologies is a leading supplier of analog interface components for communications, industrial and consumer applications. By leveraging its core competencies in III-V compound and silicon semiconductor design and processing, the company provides an extensive range of analog, mixed signal and optoelectronics components and subsystems to more than 40,000 customers. Backed by strong customer service support, the company's products serve four diverse end markets: industrial and automotive, wired infrastructure, wireless communications, and computer peripherals. Avago has a global employee presence and heritage of technical innovation dating back 40 years to its Hewlett-Packard roots. Information about Avago is available on the Web at www.avagotech.com

For product information and a complete list of distributors, please go to our web site:

www.avagotech.com

www.avagotech.com/optocouplers

For technical support please email a Technical Response Center in your region:

United States: support@avagotech.com

Europe: info@promotionteam.de

Asia Pacific: pacrim.components@avagotech.com