

Application Note 5413

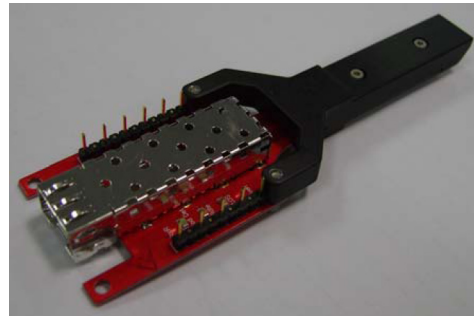

SFP Extender Board

The SFP extender board was designed to access SFP low speed control signals while a DUT SFP compliant to SFF-8074 is plugged into the target application system such as a network switch and router. TX and RX high speed signals are routed on the board with 50 Ω transmission lines to maintain signal integrity. The extender board is a useful tool for trouble shooting any problems associated with SFP's running in systems. This SFP extender board is not intended for SFP+ use however, it can still be used to monitor SFP+ low speed control signals.

I. SFP Extender board description

Top view of the extender board is shown in Figure 1. The extender board has probe pins to monitor the signals shown in Table.1. A black anodized housing shell supports the extender board with measurement equipment probes hooked up to the probe pins. The housing also helps the extender board to mate host connector with correct polarity.

The extender board PCB has two separate TX and RX GNDs, however they are tied together with a 0 Ω SMT resistor. The cage on the PCB is isolated from the circuit GND. The black anodized housing is also isolated from circuit GND.

LED's on the extender board turn on/off following the signal levels as shown in Table.1. LED's next to LOS, Rate Seletc, TX_Fault, SDA and SCL probe pins turn on when these signals are at TTL high level. LED's next to Mod_Def0 and TX_Disable are turned on when the signals are at TTL low state, indicating that module is present and TX is enabled respectively.

TX VCC and RX VCC probe pins have 330 Ω resistors in between the pins and power supply to protect host power supply from accidental shorting.

All signals other than VCC and GND pins are pulled up to RX VCC via 100 k Ω resistors to drive the LED driver IC U2. These 100 k Ω resistors are in parallel with host pull-up resistors. See the extender board schematic Figure 2 for the details.

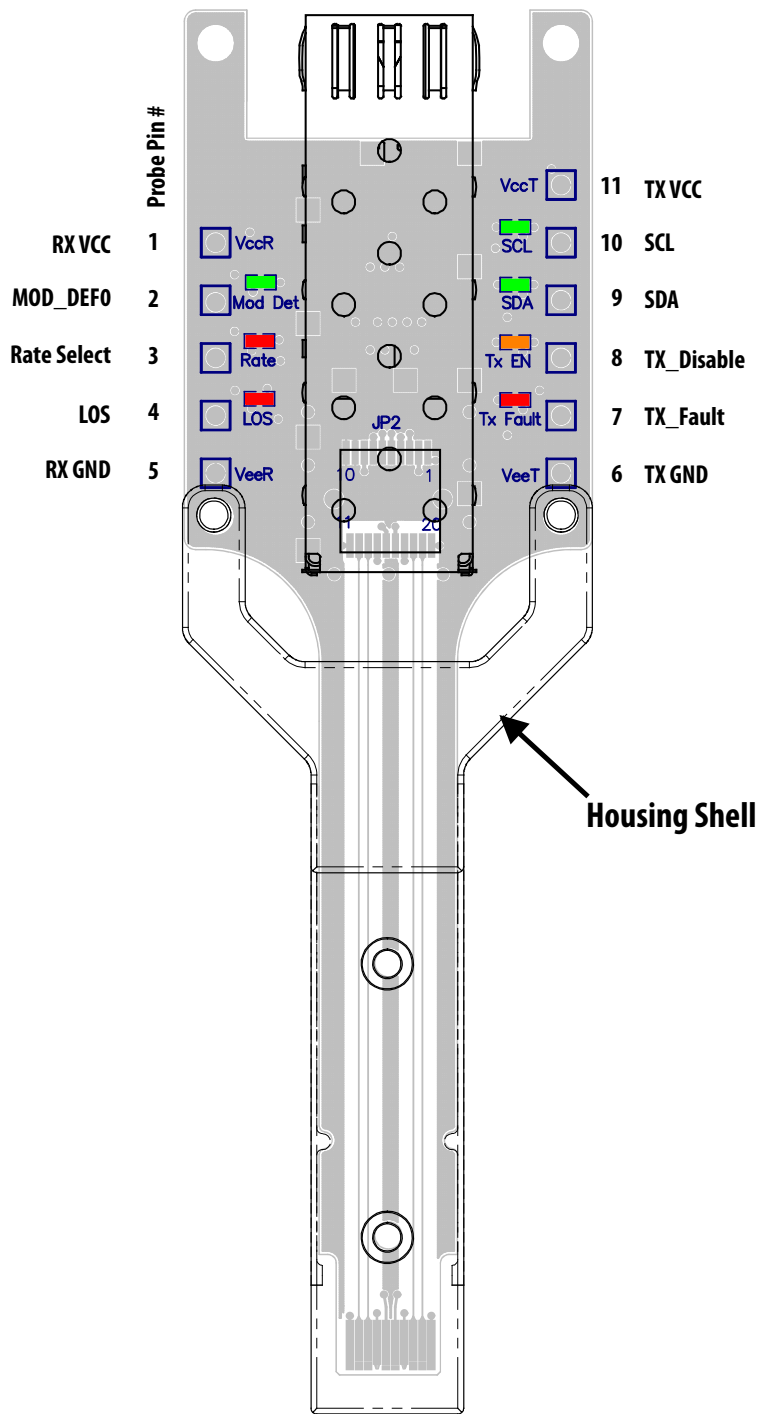

Figure 1. SFP Extender Board Top View

Table 1. Probe pins on SFP extender board

Probe Pin #	Signal Name	LED Color	LED ON when	Signals electrical connection on the board
1	VCCR			RX VCC via a 330 Ω protection resistor
2	Mod_def0	Green	Mod_def0 is low (module present)	Pulled up to VCCR with a 100 kΩ resistor
3	Rate_Select	Red	Rate_select is high	RS0 pulled up to VCCR with a 100 kΩ resistor
4	LOS	Red	LOS is high	Pulled up to VCCR with a 100 kΩ resistor
5	VEER			RX GND. Tied to TX GND with a 0 Ω SMT resistor
6	VEET			TX GND. Tied to RX GND with a 0 Ω SMT resistor
7	TX_Fault	Red	TX_Fault is high	Pulled up to VCCR with a 100 kΩ resistor
8	TX_Disable	Orange	TX_Disable is low	Pulled up to VCCR with a 100 kΩ resistor
9	SDA	Green	SDA is high	Two-wire serial data pulled up to VCCR with a 100 kΩ resistor
10	SCL	Green	SCL is high	Two-wire serial clock pulled up to VCCR with a 100 kΩ resistor
11	VCCT			TX VCC via a 330 Ω protection resistor

II. How to use AVAGO SFP Extender Board

The SFP Extender Board can be used to measure voltage level and timing of SFP interface signals. Various measurement equipment such as a digital voltmeter, oscilloscope and logic analyzer can be connected to the extender board probe pins 1 to 11 on Figure 1.

Plug the SFP extender board into the application system. Then plug the SFP module into the cage on the extender

board. Plug fiber optic cables to the SFP module optical ports if necessary. Connect the digital voltmeter leads to VCCR and VEER pins on the extender board as shown in Figure 2. Read the RX VCC voltage from the digital voltmeter and check the LED's on the extender board. Note that both VEER and VEET pins can be used as circuit GND as they are at the same GND potential.

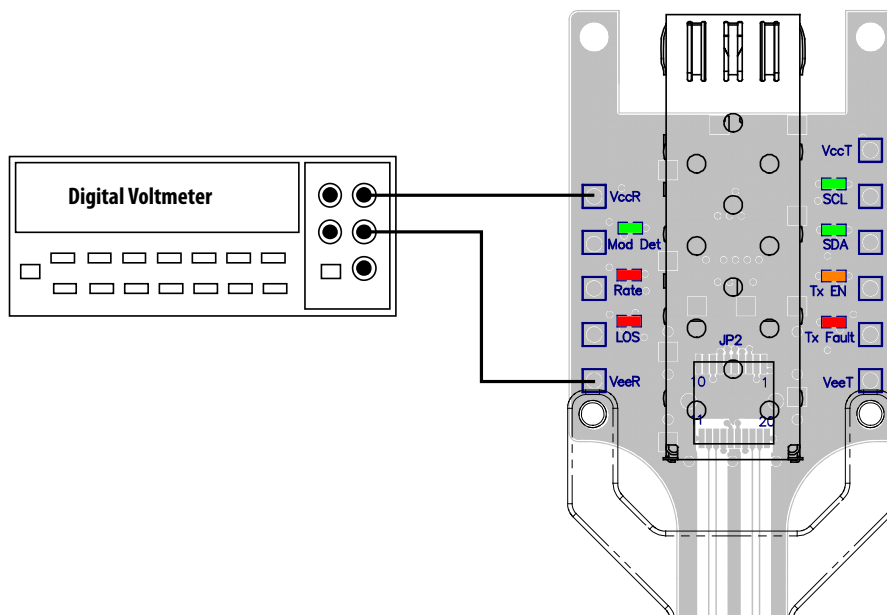

Figure 2. An example of how to use an SFP extender board to measure RX VCC voltage

III. Evaluation Board Schematic and Bill of Materials

The SFP Extender Board schematic is shown in Figure 3. Table 2 shows the bill of materials.

Table. 2 Bill of Material

Components	Foot Print	Quantity	Reference Designator
0.1 μ F	0603	3	C4 C5 C6
0	0603	1	R28
100 k Ω	0603	7	R6 R9 R10 R11 R29 R30 R31
330 Ω	0603	8	R1 R2 R7 R8 R12 R13 R27 R33 R32
Tyco electronics P/N 1367073-1 or Molex P/N 74441-0010	SFP Receptacle	1	JP1
LED	0603	3	D2, D3, D4 D5, D6, D7, D8
LVC240	SSOP20	1	U2
AMP P/N 4-103186	SIP1	1	J1, J2, J3, J4, J5, J6, J7, J9, J10, J11, J12
Molex 74737-0002	SFP Cage	1	

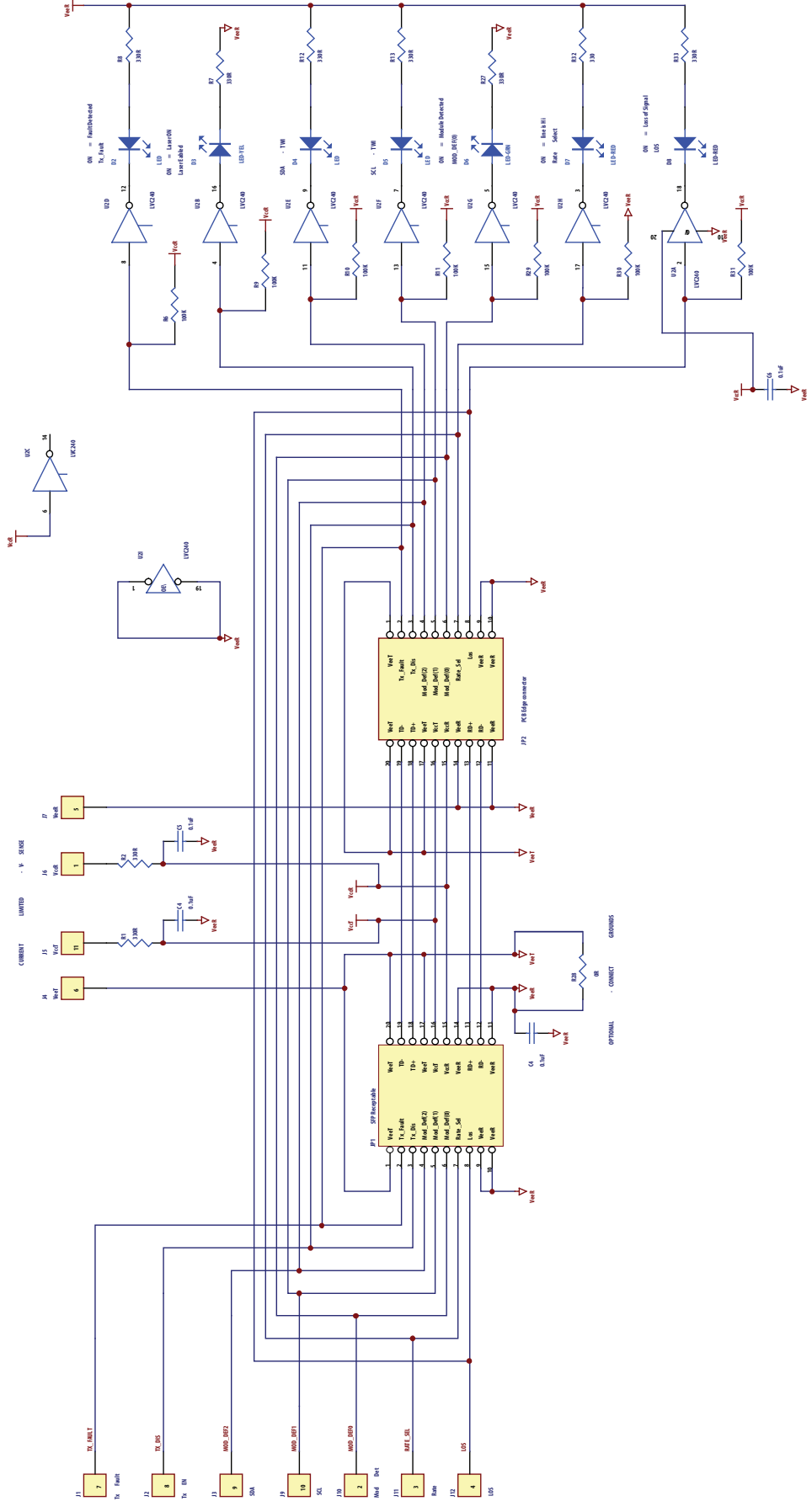

Figure3. SFP Extender Board Schematic Diagram

For product information and a complete list of distributors, please go to our web site: www.avagotech.com

Avago, Avago Technologies, and the A logo are trademarks of Avago Technologies in the United States and other countries.
Data subject to change. Copyright © 2005-2010 Avago Technologies. All rights reserved.
AV02-1696EN - August 3, 2010

