

## **HFBR-0507Z Series HFBR-15X7Z Transmitters HFBR-25X6Z Receivers 125-Megabaud Versatile Link Fiber-Optic Connection**

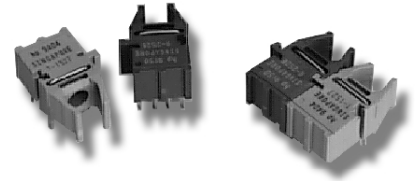

---

### **Description**

The 125-Mbaud Versatile Link (HFBR-0507Z Series) is the most cost-effective fiber-optic solution for transmission of 125-Mbaud data over 100 meters. The data link consists of a 650-nm LED transmitter, HFBR-15X7Z, and a PIN/preamp receiver, HFBR-25X6Z. These can be used with low-cost plastic or silica fiber. One-mm diameter plastic fiber provides the lowest-cost solution for distances under 25 meters. The lower attenuation of silica fiber allows data transmission over longer distance, for a small difference in cost. These components can be used for high-speed data links without the problems common with copper wire solutions, at a competitive cost.

The HFBR-15X7Z transmitter is a high-power 650-nm LED in a low-cost plastic housing that is designed to efficiently couple power into 1-mm diameter plastic optical fiber and 200- $\mu\text{m}$  hard-clad silica (HCS) fiber. With the recommended drive circuit, the LED operates at speeds from 1 to 125 Mbaud. The HFBR-25X6Z is a high bandwidth analog receiver containing a PIN photodiode and internal transimpedance amplifier. With the recommended application circuit for 125-Mbaud operation, the performance of the complete data link is specified for 0 to 25 meters with plastic fiber and 0 to 100 meters with 200- $\mu\text{m}$  HCS fiber. A wide variety of other digitizing circuits can be combined with the HFBR-0507Z Series to optimize performance and cost at higher and lower data rates.

### **Features**

- RoHS compliant
- Data transmission at signal rates of 1 to 125 Mbaud over distances of 100 meters
- Compatible with inexpensive, easily terminated plastic optical fiber, and with large-core silica fiber
- High voltage isolation
- Transmitter and receiver application circuit schematics and recommended board layouts available
- Interlocking feature for single-channel or duplex links, in a vertical or horizontal mount configuration

### **Applications**

- Intrasystem links: board-to-board, rack-to-rack
- Telecommunications switching systems
- Computer-to-peripheral data links, PC bus extension
- Industrial control
- Proprietary LANs
- Digitized video
- Medical instruments
- Reduction of lightning and voltage transient susceptibility

## HFBR-0507Z Series

### 125-Mbaud Data Link

Data-link operating conditions and performance are specified for the HFBR-15X7Z transmitter and HFBR-25X6Z receiver in the recommended applications circuits shown in [Figure 1](#). This circuit has been optimized for 125-Mbaud operation. The Applications Engineering Department in the Broadcom Optical Communication Division is available to assist in optimizing link performance for higher- or lower-speed operation.

### Recommended Operating Conditions for the Circuits in Figures 1 and 2

Parameter	Symbol	Min.	Max.	Unit	Reference
Ambient Temperature	$T_A$	0	70	°C	—
Supply Voltage	$V_{CC}$	+4.75	+5.25	V	—
Data Input Voltage – Low	$V_{IL}$	$V_{CC} - 1.89$	$V_{CC} - 1.62$	V	—
Data Input Voltage – High	$V_{IH}$	$V_{CC} - 1.06$	$V_{CC} - 0.70$	V	—
Data Output Load	$R_L$	45	55	$\Omega$	Note <sup>a</sup>
Signaling Rate	$f_S$	1	125	Mbaud	—
Duty Cycle	D.C.	40	60	%	Note <sup>b</sup>

a. If the output of U4C in [Figure 1](#) is transmitted via coaxial cable, terminate with a 50 $\Omega$  resistor to  $V_{CC} - 2V$ .

b. Run length-limited code with a maximum run length of 10  $\mu s$ .

## Link Performance

1 to 125 Mbaud, BER  $\leq 10^{-9}$ , under recommended operating conditions with recommended transmit and receive application circuits.

Parameter	Symbol	Min. <sup>a</sup>	Typ. <sup>b</sup>	Max.	Unit	Condition	Reference
Optical Power Budget, 1m POF	OPB <sub>POF</sub>	11	16	—	dB	—	Notes c, d, e
Optical Power Margin, 20m Standard POF	OPM <sub>POF,20</sub>	3	6	—	dB	—	Notes c, d, e
Link Distance with Standard 1-mm POF	l	20	27	—	m	—	—
Optical Power Margin, 25m Low Loss POF	OPM <sub>POF,25</sub>	3	6	—	dB	—	Notes c, d, e
Link Distance with Extra Low Loss 1-mm POF	l	25	32	—	m	—	—
Optical Power Budget, 1m HCS	OPB <sub>HCS</sub>	7	12	—	dB	—	Notes c, d, e
Optical Power Margin, 100m HCS	OPM <sub>HCS,100</sub>	3	6	—	dB	—	Notes c, d, e
Link Distance with HCS Cable	l	100	125	—	m	—	—

- a. Minimum link performance is projected based on the worst-case specifications of the HFBR-15X7Z transmitter, HFBR-25X6Z receiver, and POF cable, and the typical performance of other components (for example, logic gates, transistors, resistors, capacitors, quantizer, HCS cable).
- b. Typical performance is at 25°C, 125 Mbaud, and is measured with typical values of all circuit components.
- c. The standard cable is HFBR-RXXYYYY plastic optical fiber, with a maximum attenuation of 0.24 dB/m at 650 nm and NA = 0.5. Extra low loss cable is HFBR-EXXYYYY plastic optical fiber, with a maximum attenuation of 0.19 dB/m at 650 nm and NA = 0.5. The HCS cable is HFBR-H/VXYYYY glass optical fiber, with a maximum attenuation of 10 dB/km at 650 nm and NA = 0.37.
- d. The optical power budget (OPB) is the difference between the transmitter output power and the receiver sensitivity, measured after 1 meter of fiber. The minimum OPB is based on the limits of optical component performance over temperature, process, and recommended power supply variation.
- e. The optical power margin (OPM) is the available OPB after including the effects of attenuation and modal dispersion for the minimum link distance:  $OPM = OPB - (\text{attenuation power loss} + \text{modal dispersion power penalty})$ . The minimum OPM is the margin available for longterm LED LOP degradation and additional fixed passive losses (such as inline connectors) in addition to the minimum specified distance.

## Plastic Optical Fiber (1-mm POF) Transmitter Application Circuit

Performance of the HFBR-15X7Z transmitter in the recommended application circuit (Figure 1) for POF; 1 to 125 Mbaud, 25°C.

Parameter	Symbol	Typical	Unit	Condition	Note
Average Optical Power, 1-mm POF	$P_{avg}$	-9.7	dBm	50% Duty Cycle	Note <sup>a</sup> , Figure 3
Average Modulated Power, 1-mm POF	$P_{mod}$	-11.3	dBm	—	Note <sup>b</sup> , Figure 3
Optical Rise Time (10% to 90%)	$t_r$	2.1	ns	5 MHz	—
Optical Fall Time (90% to 10%)	$t_f$	2.8	ns	5 MHz	—
High Level LED Current (On)	$I_{F,H}$	19	mA	—	Note <sup>c</sup>
Low Level LED Current (Off)	$I_{F,L}$	3	mA	—	Note <sup>c</sup>
Optical Overshoot, 1-mm POF	—	45	%	—	—
Transmitter Application Circuit Current Consumption, 1-mm POF	$I_{CC}$	110	mA	—	Figure 1

- The average optical power is measured with an average power meter at 50% duty cycle, after 1 meter of fiber.
- To allow the LED to switch at high speeds, the recommended drive circuit modulates LED light output between two nonzero power levels. The modulated (useful) power is the difference between the high and low level of light output power (transmitted) or input power (received), which can be measured with an average power meter as a function of the duty cycle (see Figure 3). The average modulated power is defined as one half the slope of the average power versus the duty cycle:

$$\text{Average Modulated Power} = \frac{[P_{avg} @ 80\% \text{ duty cycle} - P_{avg} @ 20\% \text{ duty cycle}]}{(2) [0.80 - 0.20]}$$

- High- and low-level LED currents refer to the current through the HFBR-15X7Z LED. The low-level LED “off” current, sometimes referred to as “hold-on” current, is prebias supplied to the LED during the off state to facilitate fast switching speeds.

## Hard-Clad Silica Fiber (200- $\mu\text{m}$ HCS) Transmitter Application Circuit

Performance of the HFBR-15X7Z transmitter in the recommended application circuit (Figure 1) for HCS; 1 to 125 Mbaud, 25°C.

Parameter	Symbol	Typical	Unit	Condition	Note
Average Optical Power, 200- $\mu\text{m}$ HCS	$P_{\text{avg}}$	-14.6	dBm	50% Duty Cycle	Note <sup>a</sup> , Figure 3
Average Modulated Power, 200- $\mu\text{m}$ HCS	$P_{\text{mod}}$	-16.2	dBm	—	Note <sup>b</sup> , Figure 3
Optical Rise Time (10% to 90%)	$t_r$	3.1	ns	5 MHz	—
Optical Fall Time (90% to 10%)	$t_f$	3.4	ns	5 MHz	—
High Level LED Current (On)	$I_{F,H}$	60	mA	—	Note <sup>c</sup>
Low Level LED Current (Off)	$I_{F,L}$	6	mA	—	Note <sup>c</sup>
Optical Overshoot, 200- $\mu\text{m}$ HCS	—	30	%	—	—
Transmitter Application Circuit Current Consumption, 200- $\mu\text{m}$ HCS	$I_{\text{CC}}$	130	mA	—	Figure 1

- a. The average optical power is measured with an average power meter at 50% duty cycle, after 1 meter of fiber.
- b. To allow the LED to switch at high speeds, the recommended drive circuit modulates LED light output between two nonzero power levels. The modulated (useful) power is the difference between the high and low level of light output power (transmitted) or input power (received), which can be measured with an average power meter as a function of the duty cycle (see Figure 3). The average modulated power is defined as one half the slope of the average power versus the duty cycle:

$$\text{Average Modulated Power} = \frac{[P_{\text{avg}} @ 80\% \text{ duty cycle} - P_{\text{avg}} @ 20\% \text{ duty cycle}]}{(2) [0.80 - 0.20]}$$

- c. High- and low-level LED currents refer to the current through the HFBR-15X7Z LED. The low-level LED “off” current, sometimes referred to as “hold-on” current, is prebias supplied to the LED during the off state to facilitate fast switching speeds.

## Plastic and Hard-Clad Silica Optical Fiber Receiver Application Circuit

Performance<sup>a</sup> of the HFBR-25X6Z receiver in the recommended application circuit ([Figure 1](#)); 1 to 125 Mbaud, 25°C, unless otherwise stated.

Parameter	Symbol	Typical	Unit	Condition	Note
Data Output Voltage - Low	$V_{OL}$	$V_{CC} - 1.7$	V	$R_L = 50\Omega$	Note <sup>b</sup>
Data Output Voltage - High	$V_{OH}$	$V_{CC} - 0.9$	V	$R_L = 50\Omega$	Note <sup>b</sup>
Receiver Sensitivity to Average Modulated Optical Power, 1-mm POF	$P_{min}$	-27.5	dBm	50% eye opening	Note <sup>c</sup>
Receiver Sensitivity to Average Modulated Optical Power, 200- $\mu$ m HCS	$P_{min}$	-28.5	dBm	50% eye opening	Note <sup>c</sup>
Receiver Overdrive Level of Average Modulated Optical Power, 1-mm POF	$P_{max}$	-7.5	dBm	50% eye opening	Note <sup>c</sup>
Receiver Overdrive Level of Average Modulated Optical Power, 200- $\mu$ m HCS	$P_{max}$	-10.5	dBm	50% eye opening	Note <sup>c</sup>
Receiver Application Circuit Current Consumption	$I_{CC}$	85	mA	$R_L = \infty$	<a href="#">Figure 1</a>

- a. Performance in response to a signal from the HFBR-15X7Z transmitter driven with the recommended circuit at 1 to 125 Mbaud over 1 meter of HFBR-RZ/EXXYYYY plastic optical fiber or 1 meter of HFBR-H/VXXYYY hard-clad silica optical fiber.
- b. Terminated through a 50 $\Omega$  resistor to  $V_{CC} - 2V$ .
- c. If there is no input optical power to the receiver, electrical noise can result in false triggering of the receiver. In typical applications, data encoding and error detection prevent random triggering from being interpreted as valid data. Refer to [Application Note 1066](#) for design guidelines.

Figure 1: Transmitter and Receiver Application Circuit with +5V ECL Inputs and Outputs

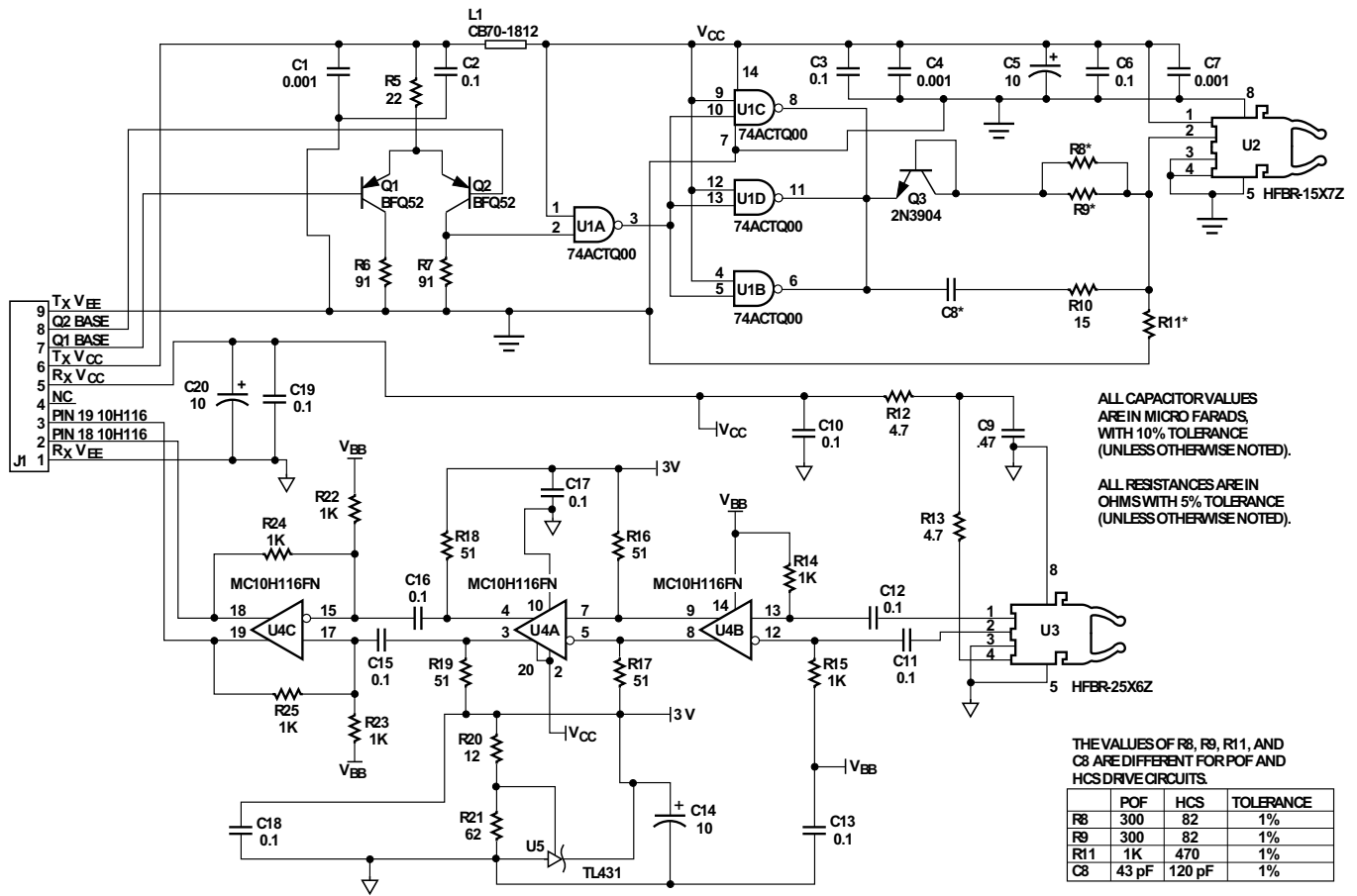

Figure 2: Recommended Power Supply Filter and +5V ECL Signal Terminations for the Transmitter and Receiver Application Circuit of Figure 1

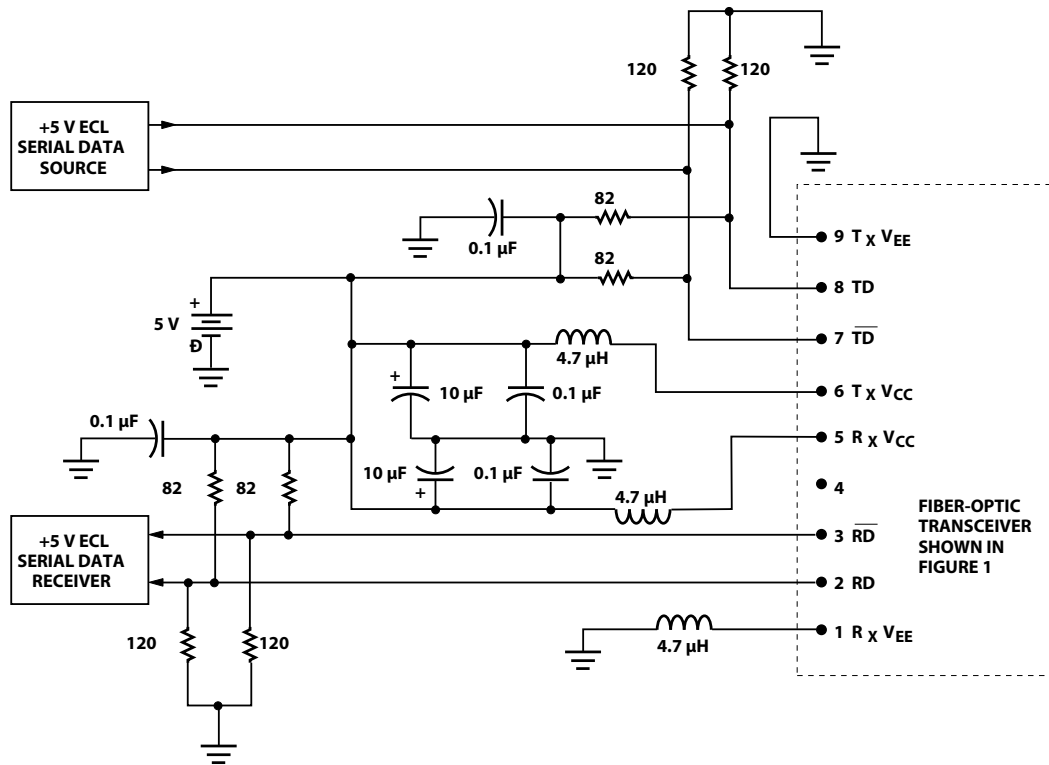

Figure 3: Average Modulated Power

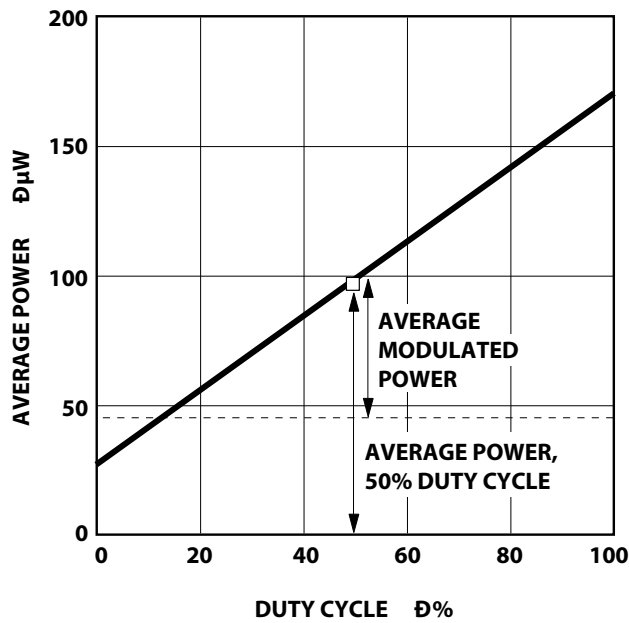
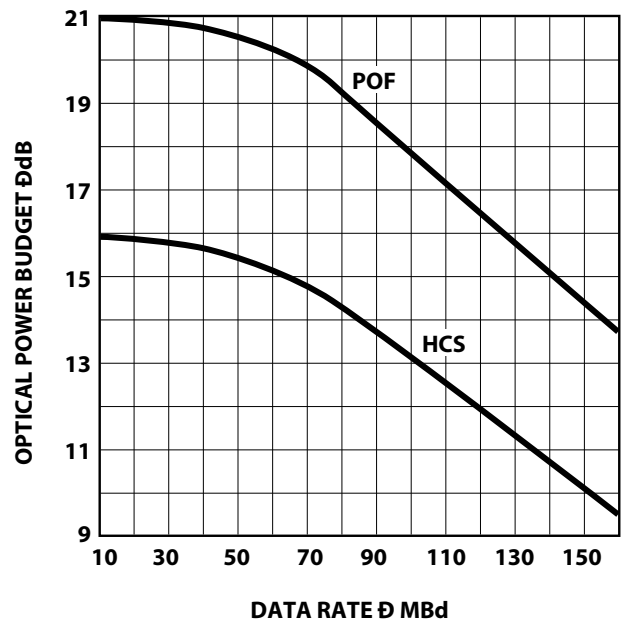

Figure 4: Typical Optical Power Budget vs. Data Rate





# 125-Megabaud Versatile Link Transmitter

## HFBR-15X7Z Series

### Description

The HFBR-15X7Z transmitters incorporate a 650-nm LED in a horizontal (HFBR-1527Z) or vertical (HFBR-1537Z) gray housing. The HFBR-15X7Z transmitters are suitable for use with current peaking to decrease response time, and they can be used with HFBR-25X6Z receivers in data links operating at signal rates from 1 to 125 megabaud over 1-mm diameter plastic optical fiber or 200- $\mu$ m diameter hard-clad silica glass optical fiber. Refer to [Application Note 1066](#) for details on recommended interface circuits.

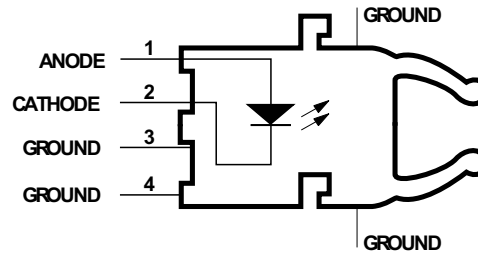

**NOTE:** Pins 5 and 8 are primarily for mounting and retaining purposes, but are electrically connected; pins 3 and 4 are electrically unconnected. It is recommended that pins 3, 4, 5, and 8 all be connected to ground to reduce coupling of electrical noise.

### Absolute Maximum Ratings

Parameter	Symbol	Min.	Max.	Unit	Reference
Storage Temperature	$T_S$	-40	85	$^{\circ}\text{C}$	—
Operating Temperature	$T_O$	-40	70	$^{\circ}\text{C}$	—
Lead Soldering Temperature Cycle Time	—	—	260	$^{\circ}\text{C}$	Note <sup>a, b</sup>
	—	—	10	s	
Transmitter High Level Forward Input Current	$I_{F,H}$	—	120	mA	50% Duty Cycle $\geq 1$ MHz
Transmitter Average Forward Input Current	$I_{F,AV}$	—	60	mA	—
Reverse Input Voltage	$V_R$	—	3	V	—

a. 1.6 mm below the seating plane. To guard against solder process fluctuations, the recommended nominal soldering time is 5 seconds.

b. The moisture sensitivity level (MSL) is 3.

**CAUTION!** The small junction sizes inherent to the design of this component increase the component's susceptibility to damage from electrostatic discharge (ESD). It is advised that normal static precautions be taken in handling and assembly of this component to prevent damage and/or degradation that may be induced by ESD.

**WARNING!** When viewed under some conditions, the optical port may expose the eye beyond the maximum permissible exposure recommended in ANSI Z136.2, 1993. Under most viewing conditions, there is no eye hazard.

## Electrical/Optical Characteristics

0 to 70°C, unless otherwise stated.

Parameter	Symbol	Min.	Typ. <sup>a</sup>	Max.	Unit	Condition	Note
Transmitter Output Optical Power, 1-mm POF	$P_T$	-9.5	-7.0	-4.8	dBm	$I_{F,dc} = 20 \text{ mA}, 25^\circ\text{C}$ 0–70°C	Note <sup>b</sup>
		-10.4	—	-4.3			
Transmitter Output Optical Power, 1-mm POF	$P_T$	-6.0	-3.0	-0.5	dBm	$I_{F,dc} = 60 \text{ mA}, 25^\circ\text{C}$ 0–70°C	Note <sup>b</sup>
		-6.9	—	0.0			
Transmitter Output Optical Power, 200- $\mu\text{m}$ HCS	$P_T$	-14.6	-13.0	-10.5	dBm	$I_{F,dc} = 60 \text{ mA}, 25^\circ\text{C}$ 0–70°C	Note <sup>b</sup>
		-15.5	—	-10.0			
Output Optical Power Temperature Coefficient	$\Delta P_T/\Delta T$	—	-0.02	—	dB/°C	—	—
Peak Emission Wavelength	$\lambda_{PK}$	640	650	660	nm	—	—
Peak Wavelength Temperature Coefficient	$\Delta\lambda/\Delta T$	—	0.12	—	nm/°C	—	—
Spectral Width	FWHM	—	21	—	nm	Full Width, Half Maximum	—
Forward Voltage	$V_F$	1.8	2.1	2.4	V	$I_F = 60 \text{ mA}$	—
Forward Voltage Temperature Coefficient	$\Delta V_F/\Delta T$	—	-1.8	—	mV/°C	—	—
Transmitter Numerical Aperture	NA	—	0.5	—	—	—	—
Thermal Resistance, Junction to Case	$\theta_{jc}$	—	140	—	°C/W	—	Note <sup>c</sup>
Reverse Input Breakdown Voltage	$V_{BR}$	3.0	13	—	V	$I_{F,dc} = -10 \mu\text{A}$	—
Diode Capacitance	$C_O$	—	60	—	pF	$V_F = 0\text{V}$ , $f = 1 \text{ MHz}$	—
Unpeaked Optical Rise Time, 10% – 90%	$t_r$	—	12	—	ns	$I_F = 60 \text{ mA}$ $f = 100 \text{ kHz}$	Figure 1 Note <sup>d</sup>
Unpeaked Optical Fall Time, 90% – 10%	$t_f$	—	9	—	ns	$I_F = 60 \text{ mA}$ $f = 100 \text{ kHz}$	Figure 1 Note <sup>d</sup>

- Typical data is at 25°C.
- The optical power is measured at the end of 0.5 meter of 1-mm diameter plastic or 200- $\mu\text{m}$  diameter hard-clad silica optical fiber with a large area detector.
- The typical value is measured from the junction to the PC board solder joint for the horizontal mount package, HFBR-1527Z.  $\theta_{jc}$  is approximately 30°C/W higher for the vertical mount package, HFBR-1537Z.
- Optical rise and fall times can be reduced with the appropriate driver circuit; refer to [Application Note 1066](#).

Refer to the *Versatile Link Family Fiber Optic Cable and Connectors* technical data sheet for cable connector options for 1-mm plastic optical fiber and 200- $\mu\text{m}$  HCS fiber.

The LED current peaking necessary for high-frequency circuit design contributes to electromagnetic interference (EMI). Care must be taken in circuit board layout to minimize emissions for compliance with governmental EMI emissions regulations. Refer to [Application Note 1066](#) for design guidelines.

**Figure 5: Test Circuit for Measuring Unpeaked Rise and Fall Times**

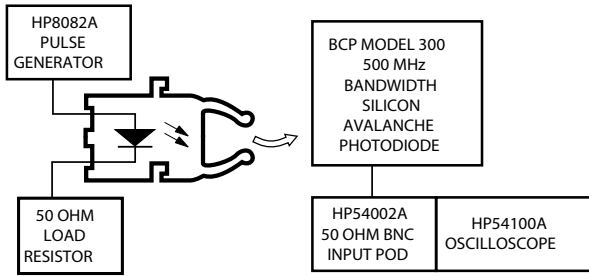

**Figure 6: Typical Spectra Normalized to the 25°C Peak**

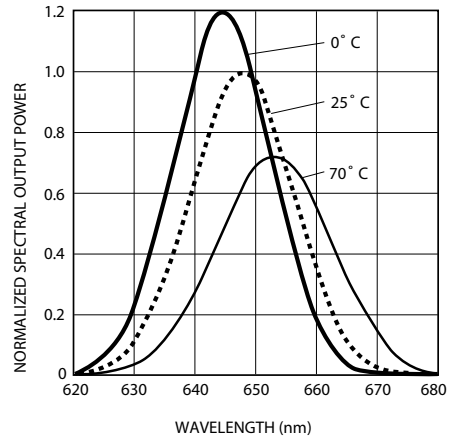

**Figure 7: Typical Forward Voltage vs. Drive Current**

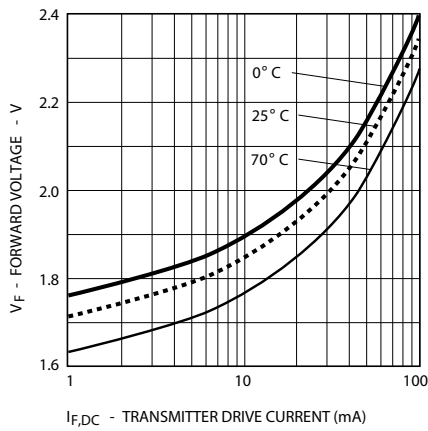

**Figure 8: Typical Normalized Output Optical Power vs. Drive Current**

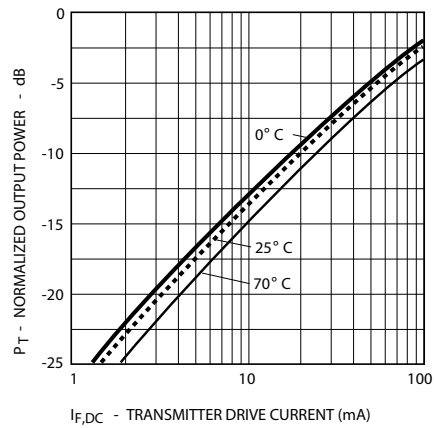

# 125-Megabaud Versatile Link Receiver

## HFBR-25X6Z Series

### Description

The HFBR-25X6Z receivers contain a PIN photodiode and transimpedance preamplifier circuit in a horizontal (HFBR-2526Z) or vertical (HFBR-2536Z) blue housing, and they are designed to interface to 1-mm diameter plastic optical fiber or 200- $\mu\text{m}$  hard-clad silica glass optical fiber. The receivers convert a received optical signal to an analog output voltage. Follow-on circuitry can optimize link performance for a variety of distance and data rate requirements. Electrical bandwidth greater than 65 MHz allows design of high-speed data links with plastic or hard-clad silica optical fiber. Refer to [Application Note 1066](#) for details on recommended interface circuits.

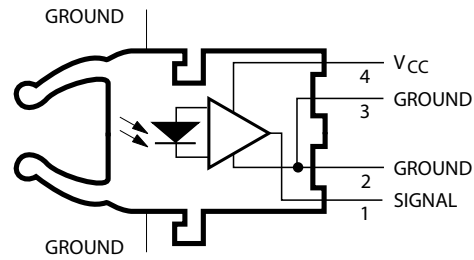

#### NOTE:

- The signal output is an emitter follower, which does not reject noise in the power supply. The power supply must be filtered as in [Figure 1](#).
- Pin 1 should be AC coupled to a load  $\geq 510\Omega$  with a load capacitance less than 5 pF.
- Pins 5 and 8 are primarily for mounting and retaining purposes, but are electrically connected. It is recommended that these pins be connected to ground to reduce coupling of electrical noise.

### Absolute Maximum Ratings

Parameter	Symbol	Min.	Max.	Unit	Reference
Storage Temperature	$T_S$	-40	+75	$^{\circ}\text{C}$	—
Operating Temperature	$T_A$	0	+70	$^{\circ}\text{C}$	—
Lead Soldering Temperature	—	—	260	$^{\circ}\text{C}$	Note <sup>a, b</sup>
Cycle Time	—	—	10	s	
Signal Pin Voltage	$V_O$	-0.5	$V_{CC}$	V	—
Supply Voltage	$V_{CC}$	-0.5	6.0	V	—
Output Current	$I_O$	—	25	mA	—

a. 1.6 mm below the seating plane. To guard against solder process fluctuations, the recommended nominal soldering time is 5 seconds.

b. The moisture sensitivity level (MSL) is 4.

**CAUTION!** The small junction sizes inherent to the design of this component increase the component's susceptibility to damage from electrostatic discharge (ESD). It is advised that normal static precautions be taken in handling and assembly of this component to prevent damage and/or degradation that may be induced by ESD.

## Electrical/Optical Characteristics

0 to 70°C; 5.25V ≥ V<sub>CC</sub> ≥ 4.75V; power supply must be filtered (see Figure 1, Note a).

Parameter	Symbol	Min.	Typ. <sup>b</sup>	Max.	Unit	Test Condition	Note
AC Responsivity, 1-mm POF	R <sub>P,APF</sub>	1.7	3.9	6.5	mV/μW	650 nm	Note <sup>c</sup>
AC Responsivity, 200-μm HCS	R <sub>P,HCS</sub>	4.5	7.9	11.5	mV/μW		
RMS Output Noise	V <sub>NO</sub>	—	0.46	0.69	mV <sub>RMS</sub>	—	Note <sup>d</sup>
Equivalent Optical Noise Input Power, RMS, 1-mm POF	P <sub>N,RMS</sub>	—	-39	-36	dBm	—	Note <sup>c</sup>
Equivalent Optical Noise Input Power, RMS, 200-μm HCS	P <sub>N,RMS</sub>	—	-42	-40	dBm	—	Note <sup>c</sup>
Peak Input Optical Power, 1-mm POF	P <sub>R</sub>	—	—	-5.8	dBm	5 ns PWD	Note <sup>e</sup>
		—	—	-6.4	dBm	2 ns PWD	
Peak Input Optical Power, 200-μm HCS	P <sub>R</sub>	—	—	-8.8	dBm	5 ns PWD	Note <sup>d</sup>
		—	—	-9.4	dBm	2 ns PWD	
Output Impedance	Z <sub>O</sub>	—	30	—	Ω	50 MHz	Note <sup>b</sup>
DC Output Voltage	V <sub>O</sub>	0.8	1.8	2.6	V	P <sub>R</sub> = 0 μW	—
Supply Current	I <sub>CC</sub>	—	9	15	mA	—	—
Electrical Bandwidth	BW <sub>E</sub>	65	125	—	MHz	-3 dB electrical	—
Bandwidth * Rise Time	—	—	0.41	—	Hz * s	—	—
Electrical Rise Time, 10–90%	t <sub>r</sub>	—	3.3	6.3	ns	P <sub>R</sub> = -10 dBm peak	—
Electrical Fall Time, 90–10%	t <sub>f</sub>	—	3.3	6.3	ns	P <sub>R</sub> = -10 dBm peak	—
Pulse Width Distortion	PWD	—	0.4	1.0	ns	P <sub>R</sub> = -10 dBm peak	Note <sup>f</sup>
Overshoot	—	—	4	—	%	P <sub>R</sub> = -10 dBm peak	Note <sup>g</sup>

- a. The signal output is an emitter follower, which does not reject noise in the power supply. The power supply must be filtered as in Figure 1.
- b. Typical data is at 25°C.
- c. Pin 1 should be AC coupled to a load ≥ 510Ω with a load capacitance less than 5 pF.
- d. Measured with a 3-pole Bessel filter with a 75-MHz, -3dB bandwidth.
- e. The maximum peak input optical power is the level at which the pulse width distortion is guaranteed to be less than the PWD listed under the test condition. P<sub>R,Max</sub> is given for PWD = 5 ns for designing links at ≤ 50-Mbaud operation and also for PWD = 2 ns for designing links up to 125 Mbaud (for both POF and HCS input conditions).
- f. 10-ns pulse width, 50% duty cycle, at the 50% amplitude point of the waveform.
- g. The percent overshoot is defined as follows:

$$\frac{(V_{PK} - V_{100\%})}{V_{100\%}} \times 100\%$$

If there is no input optical power to the receiver (no transmitted signal), electrical noise can result in false triggering of the receiver. In typical applications, data encoding and error detection prevent random triggering from being interpreted as valid data. Refer to Application Note 1066 for design guidelines.

Figure 9: Recommended Power Supply Filter Circuit

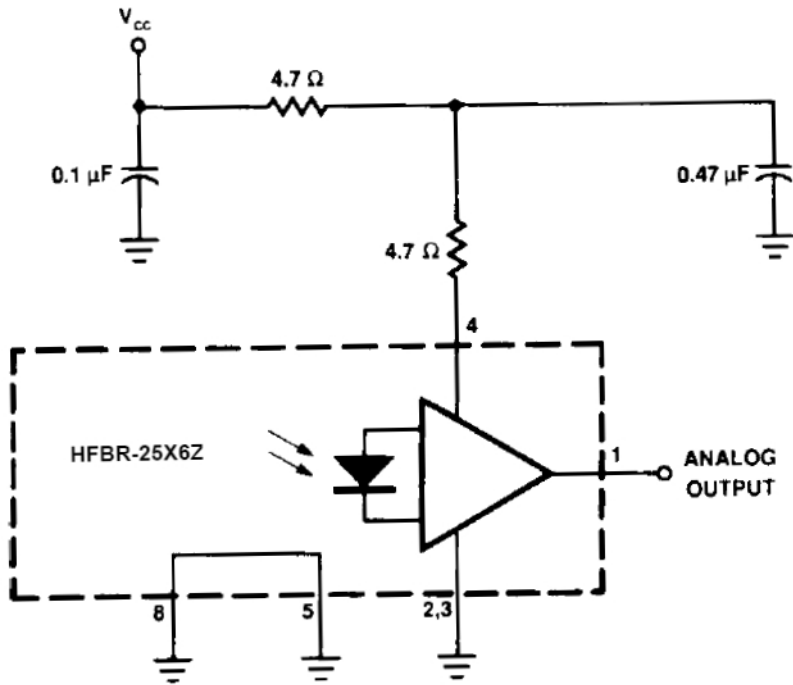

Figure 10: Simplified Receiver Schematic

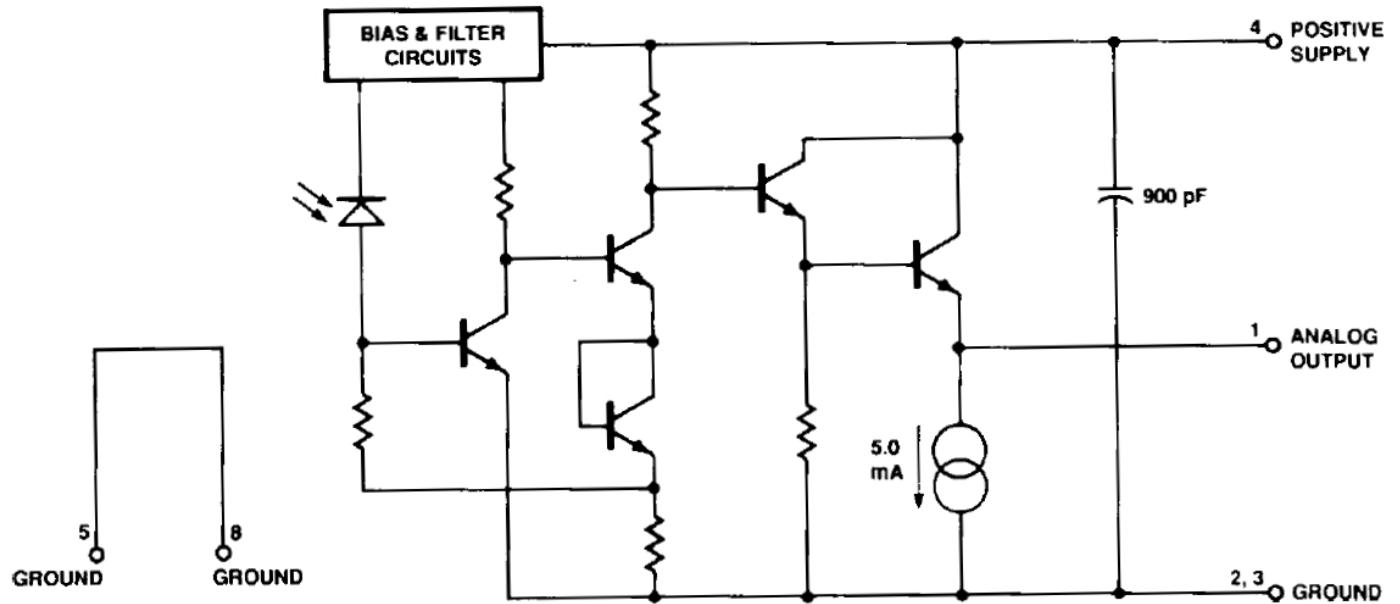

Figure 11: Typical Pulse Width Distortion vs. Peak Input Power

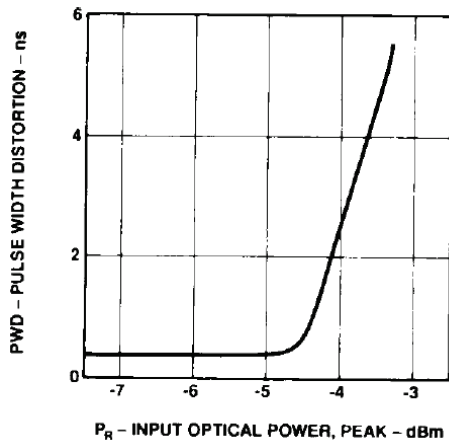

Figure 12: Typical Output Spectral Noise Density vs. Frequency

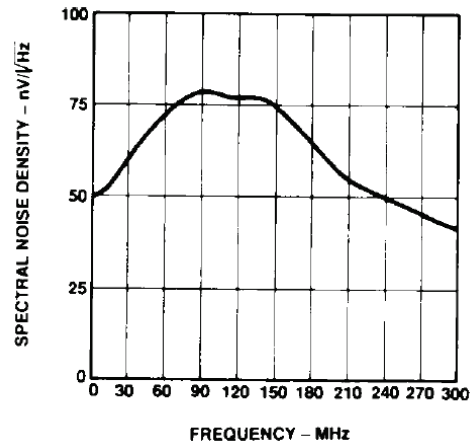
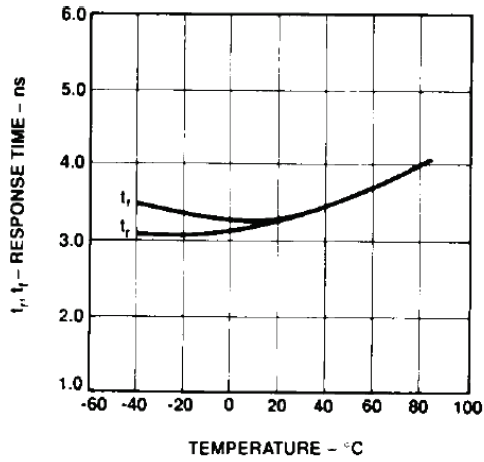

Figure 13: Typical Rise and Fall Time vs. Temperature



# Versatile Link Mechanical Dimensions

## HORIZONTAL MODULES

HFBR-1527Z  
 HFBR-2526Z

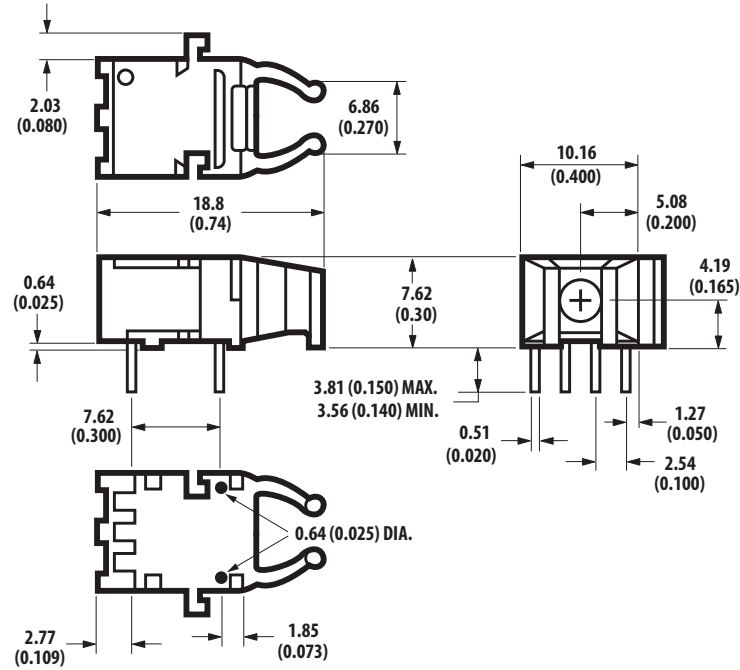

## HORIZONTAL MODULES

HFBR-1537Z  
 HFBR-2526Z

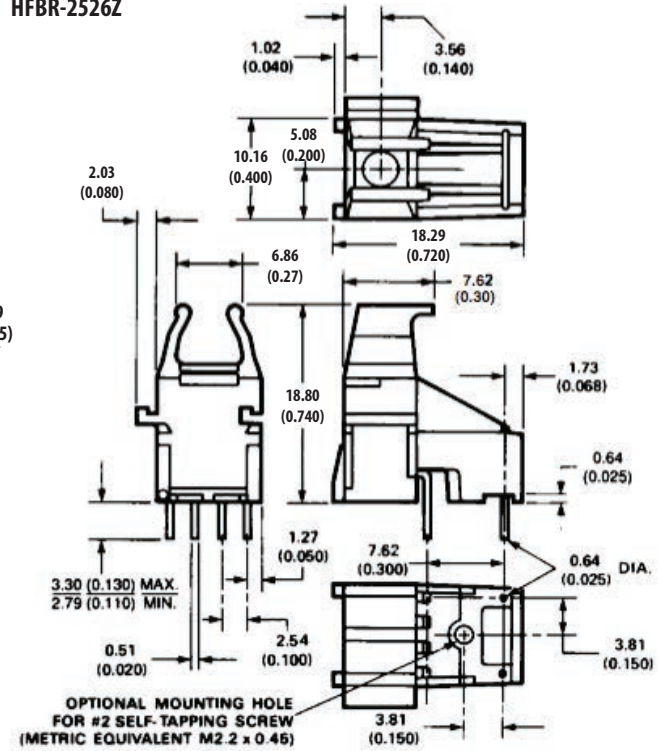



# Versatile Link Printed Circuit Board Layout Dimensions

## TOP VIEWS

### HORIZONTAL MODULE

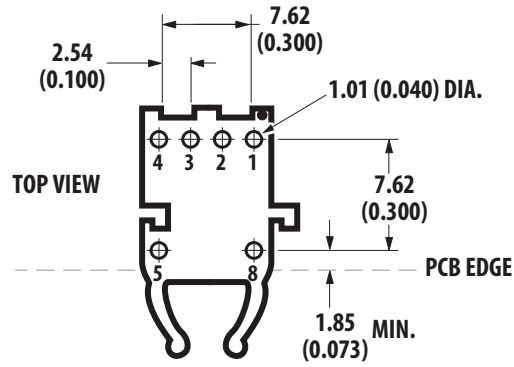

### VERTICAL MODULE

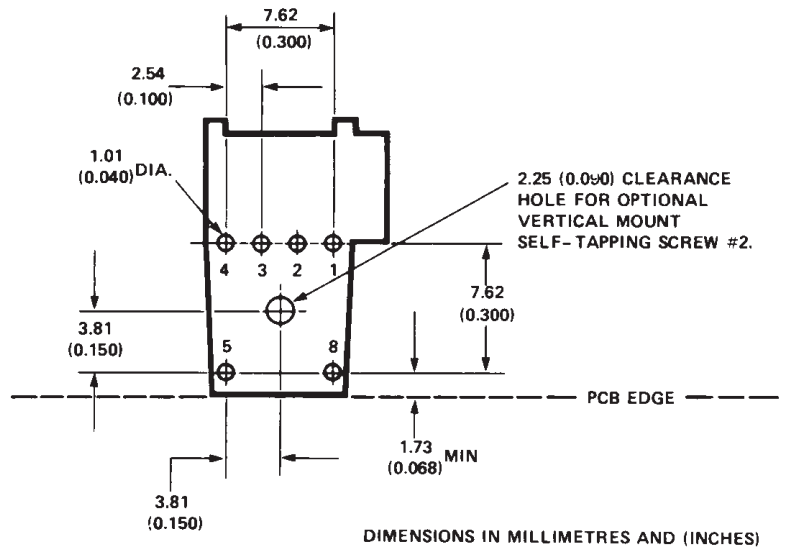

DIMENSIONS IN MILLIMETERS (INCHES).

### ELECTRICAL PIN FUNCTIONS

PIN NO.	TRANSMITTERS HFBR-15x7Z	RECEIVERS HFBR-25x6Z
1	ANODE	SIGNAL
2	CATHODE	GROUND
3	GROUND*	GROUND
4	GROUND*	V <sub>CC</sub> (+5 V)
5	GROUND**	GROUND**
8	GROUND**	GROUND**

\*NO INTERNAL CONNECTION.

\*\*PINS 5 AND 8 CONNECTED INTERNALLY TO EACH OTHER ONLY.

Copyright © 2005–2023 Broadcom. All Rights Reserved. The term “Broadcom” refers to Broadcom Inc. and/or its subsidiaries. For more information, go to [www.broadcom.com](http://www.broadcom.com). All trademarks, trade names, service marks, and logos referenced herein belong to their respective companies.

Broadcom reserves the right to make changes without further notice to any products or data herein to improve reliability, function, or design. Information furnished by Broadcom is believed to be accurate and reliable. However, Broadcom does not assume any liability arising out of the application or use of this information, nor the application or use of any product or circuit described herein, neither does it convey any license under its patent rights nor the rights of others.