

4N35

General Purpose Phototransistor Optocoupler

Description

The Broadcom® 4N35 is an optocoupler for general purpose applications. It contains a light-emitting diode optically coupled to a phototransistor. It is packaged in a 6-pin DIP package and is available in a wide-lead spacing option and a lead-bend SMD option. Response time, t_r , is typically 3 μ s and minimum CTR is 100% at an input current of 10 mA.

Schematic

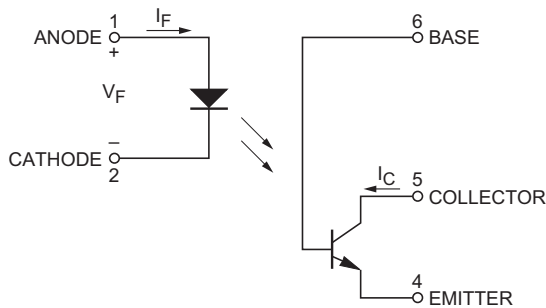

Functional Diagram

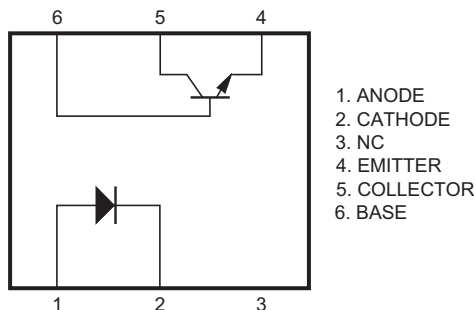

Features

- High current transfer ratio (CTR): minimum 100% at $I_F = 10\text{mA}$, $V_{CE} = 10\text{V}$
- Input-output isolation voltage (V_{iso}): 3550 Vrms
- Response time (t_r): typical, 3 μ s at $V_{CE} = 10\text{V}$, $I_C = 2\text{mA}$, $R_L = 100\Omega$
- Dual inline package
- UL approved
- CSA approved
- IEC/EN/DIN EN 60747-5-5 approved
- Options available:
 - Leads with 0.4 in. (10.16 mm) spacing (W00)
 - Leads bend for surface mounting (300)
 - Tape and reel for SMD (500)
 - IEC/EN/DIN EN 60747-5-5 approvals (060)

Applications

- I/O interfaces for computers
- System appliances, measuring instruments
- Signal transmission between circuits of different potentials and impedances

CAUTION! Take normal static precautions in the handling and assembly of this component to prevent damage and/or degradation that might be induced by electrostatic discharge (ESD). The components featured in this data sheet are not to be used in military or aerospace applications or environments.

Ordering Information

4N35-xxxx is UL Recognized with 3550 Vrms for 1 minute per UL1577 and is approved under CSA Component Acceptance Notice #5, File CA 88324.

Part Number	RoHS Component Option	Package	Surface Mount	Gull Wing	Tape and Reel	IEC/EN/DIN EN 60747-5-5	Quantity
	Rank '0', 100% < CTR						
4N35	-000E	300-mil DIP-6	—	—	—	—	65 pieces per tube
	-300E	300-mil DIP-6	X	X	—	—	65 pieces per tube
	-500E	300-mil DIP-6	X	X	X	—	1000 pieces per reel
	-060E	300-mil DIP-6	—	—	—	X	65 pieces per tube
	-360E	300-mil DIP-6	X	X	—	X	65 pieces per tube
	-560E	300-mil DIP-6	X	X	X	X	1000 pieces per reel
	-W00E	400-mil DIP-6	—	—	—	—	65 pieces per tube
	-W60E	400-mil DIP-6	—	—	—	X	65 pieces per tube

To order, choose a part number from the part number column and combine it with the desired option from the Option column to form an order entry.

Example: Select 4N35-360E to order the product consisting of a 300-mil DIP-6 DC gull wing surface mount package in tube packaging with 100%<CTR, IEC/EN/DIN EN 60747-5-5 safety approval that is RoHS compliant.

Example: Select 4N35-W00E to order the product consisting of a 400-mil DIP-6 DC package in tube packaging with 100%<CTR that is RoHS compliant.

Option data sheets are available. Contact your Broadcom sales representative or authorized distributor for information.

Package Outline Drawings

4N35-000E

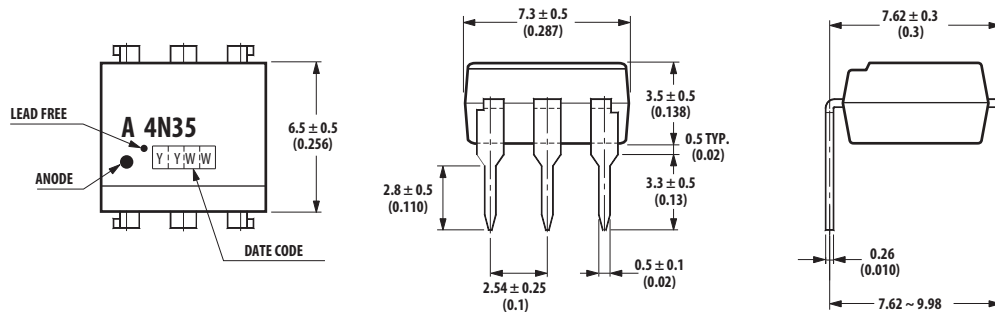

NOTE: Dimensions are in millimeters (inches).

4N35-060E

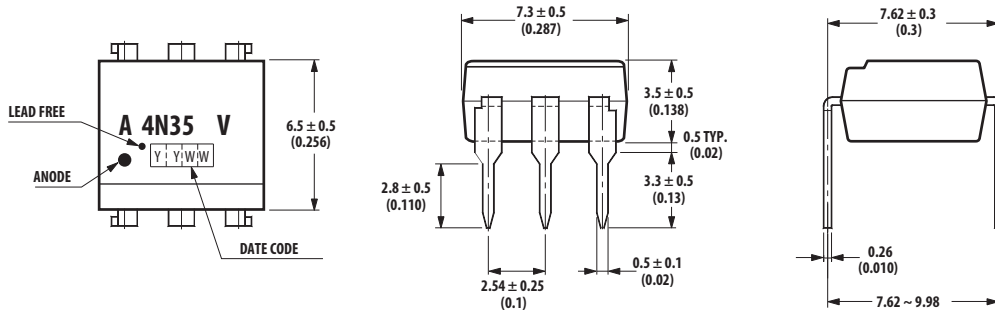

NOTE: Dimensions are in millimeters (inches).

4N35-W00E

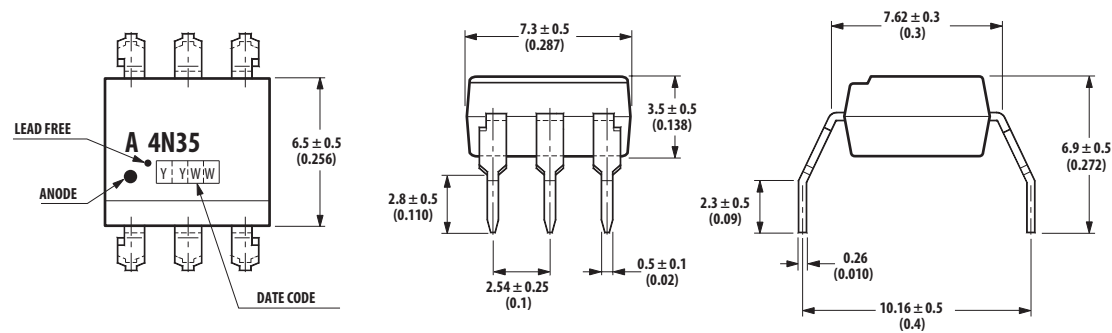

NOTE: Dimensions are in millimeters (inches).

4N35-300E

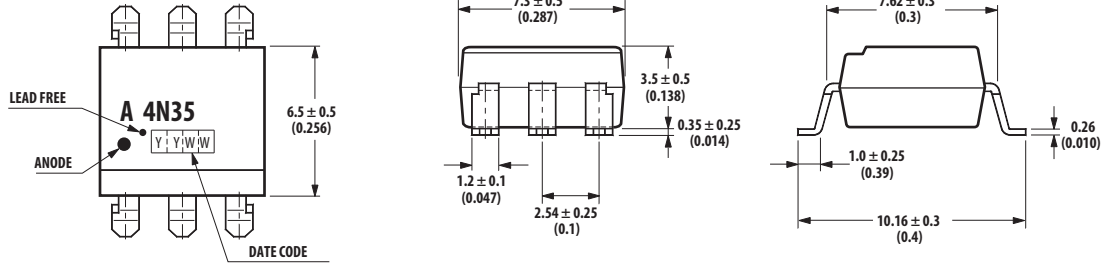

NOTE: Dimensions are in millimeters (inches).

Solder Reflow Profile

Recommended reflow conditions are as per JEDEC Standard, J-STD-020 (latest revision). Use non-halide flux.

Absolute Maximum Ratings

Parameter	Symbol	Value
Storage Temperature	T_S	-55°C to +150°C
Operating Temperature	T_A	-55°C to +100°C
Lead Solder Temperature, maximum; 1.6 mm below seating plane	—	260°C for 10 seconds
Average Forward Current	I_F	60 mA
Reverse Input Voltage	V_R	6V
Input Power Dissipation	P_I	100 mW
Collector Current	I_C	100 mA
Collector-Emitter Voltage	V_{CEO}	30V
Emitter-Collector Voltage	V_{ECO}	7V
Collector-Base Voltage	V_{CBO}	70V
Collector Power Dissipation	—	300 mW
Total Power Dissipation	—	350 mW
Isolation Voltage; AC for 1 minute, RH = 40% ~ 60%	V_{iso}	3550 Vrms

Electrical Specifications ($T_A = 25^\circ\text{C}$)

Parameter	Symbol	Min.	Typ.	Max.	Units	Test Conditions
Forward Voltage	V_F	—	1.2	1.5	V	$I_F = 10 \text{ mA}$
Reverse Current	I_R	—	—	10	μA	$V_R = 4\text{V}$
Terminal Capacitance	C_t	—	50	—	pF	$V = 0, f = 1 \text{ KHz}$
Collector Dark Current	I_{CEO}	—	—	50	nA	$V_{CE} = 10\text{V}, I_F = 0, T_A = 25^\circ\text{C}$
		—	—	500	μA	$V_{CE} = 30\text{V}, I_F = 0, T_A = 100^\circ\text{C}$
Collector-Emitter Breakdown Voltage	BV_{CEO}	30	—	—	V	$I_C = 0.1 \text{ mA}, I_F = 0$
Emitter-Collector Breakdown Voltage	BV_{ECO}	7	—	—	V	$I_E = 10 \mu\text{A}, I_F = 0$
Collector-Base Breakdown Voltage	BV_{CBO}	70	—	—	V	$I_C = 0.1 \text{ mA}, I_F = 0$
Collector Current	I_C	10	—	—	mA	$I_F = 10 \text{ mA}$
Current Transfer Ratio ^a	CTR	100	—	—	%	$V_{CE} = 10\text{V}$
Collector-Emitter Saturation Voltage	$V_{CE(sat)}$	—	—	0.3	V	$I_F = 50 \text{ mA}, I_C = 2 \text{ mA}$
Response Time (Rise)	t_r	—	3	10	μs	$V_{CC} = 10\text{V}, I_C = 2 \text{ mA}$
Response Time (Fall)	t_f	—	3	10	μs	$R_L = 100\Omega$
Isolation Resistance	R_{iso}	5×10^{10}	1×10^{11}	—	W	DC 500V, 40 ~ 60% RH
Floating Capacitance	C_f	—	1	2.5	pF	$V = 0, f = 1 \text{ MHz}$

a. Current transfer ratio in percent is defined as the ratio of collector current, I_C , to the average forward current, I_F , times 100.

Figure 1: Forward Current vs. Temperature

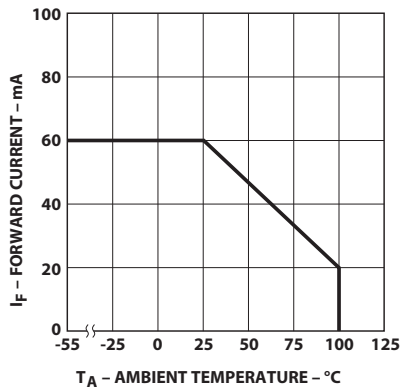

Figure 2: Collector Power Dissipation vs. Temperature

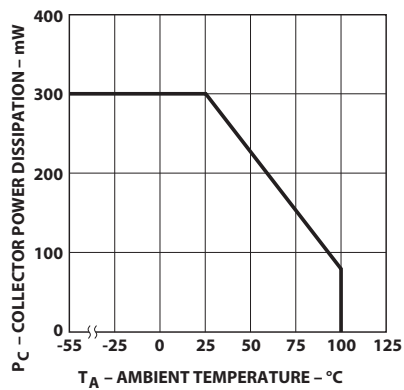

Figure 3: Forward Current vs. Forward Voltage

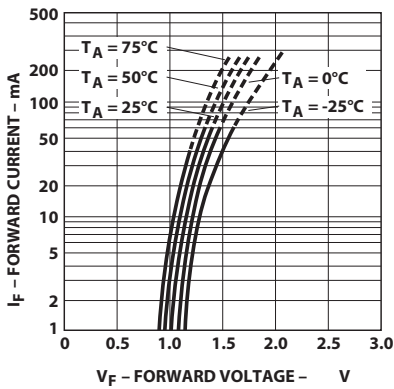

Figure 4: Current Transfer Ratio vs. Forward Current

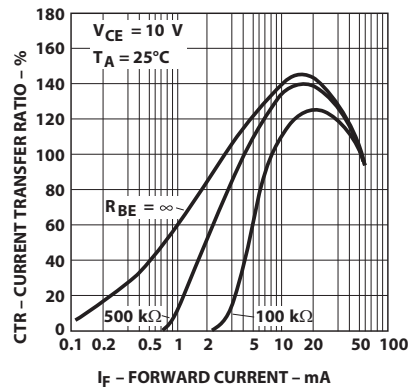

Figure 5: Collector Current vs. Collector-Emitter Voltage

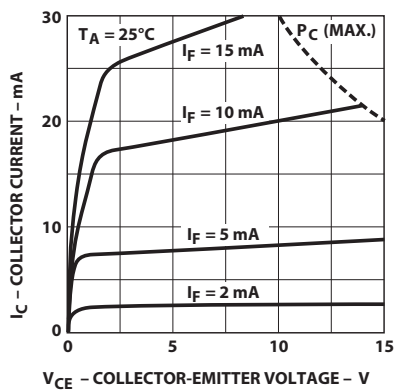

Figure 6: Relative Current Transfer Ratio vs. Temperature

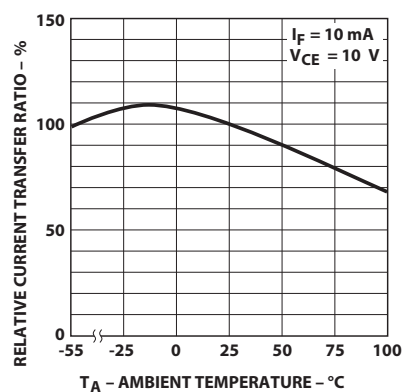

Figure 7: Collector-Emitter Saturation Voltage vs. Temperature

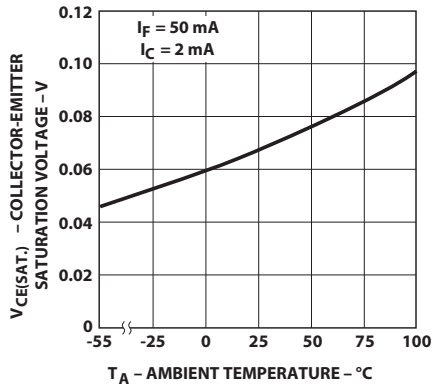

Figure 8: Collector Dark Current vs. Temperature

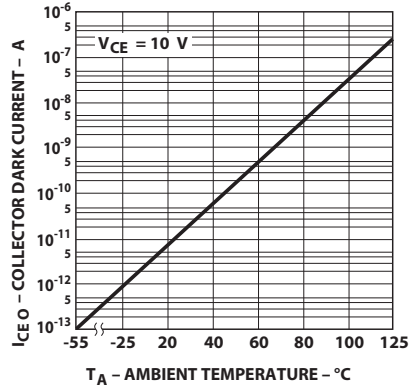

Figure 9: Response Time vs. Load Resistance

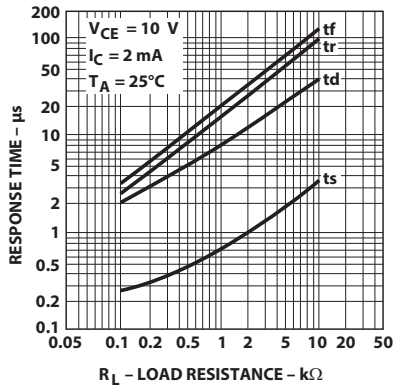

Figure 10: Frequency Response

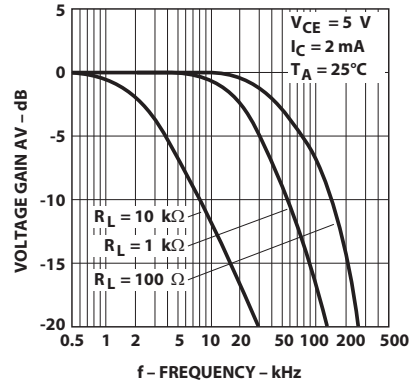
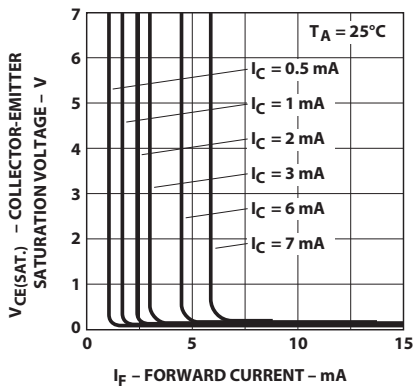
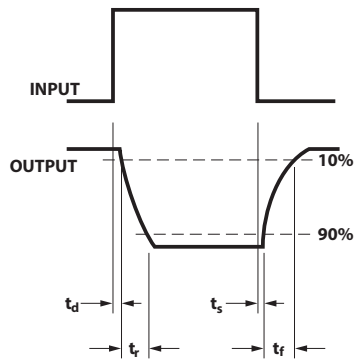
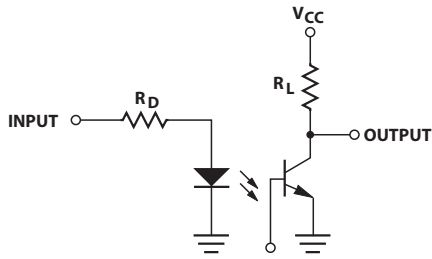

Figure 11: Collector-Emitter Saturation Voltage vs. Forward Current



Test Circuit for Response Time



Test Circuit for Frequency Response

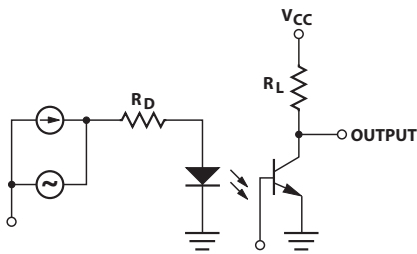

Copyright © 2007–2023 Broadcom. All Rights Reserved. The term “Broadcom” refers to Broadcom Inc. and/or its subsidiaries. For more information, go to www.broadcom.com. All trademarks, trade names, service marks, and logos referenced herein belong to their respective companies.

Broadcom reserves the right to make changes without further notice to any products or data herein to improve reliability, function, or design. Information furnished by Broadcom is believed to be accurate and reliable. However, Broadcom does not assume any liability arising out of the application or use of this information, nor the application or use of any product or circuit described herein, neither does it convey any license under its patent rights nor the rights of others.

