

## ASMT-SWBM-Nxxxx

### Surface Mount LED Indicator



### Description

The Broadcom<sup>®</sup> Long-Life White PLCC-4 SMT LED is an extension of the White PLCC-4 packages. In addition to its higher flux output, the Long-Life White PLCC-4 is designed to work under a wide range of environmental conditions with reliable and stable performance. The structure and materials used for the Long-Life White PLCC-4 enable the packages to endure minimal degradation and, hence, consistent performance throughout the product lifetime. Moreover, the Long-Life White PLCC-4 SMT LED is an 8-binned product for color, an enhanced feature from the previous PLCC-4 White, which is binned with 6 color binning only. This tighter color binning ensures better color grouping with better uniformity.

The Long-Life White PLCC-4 SMT LED is suitable to be used in interior automotive applications, and electronics signs and signals applications. In addition, the super wide viewing angle at 120° makes these LEDs ideally suited for instrument cluster panel, push button, or general backlighting in automotive interior, office equipment, industrial equipment, and home appliances. The flat top emitting surface makes it easy for these LEDs to mate with light pipes. With the built-in reflector pushing up the intensity of the light output, these super high brightness LEDs can be used in localized area ambience lighting in applications such as vanity mirror light, cabin light, and car door puddle light. The white color backlighting is suitable to backlight color LCD screens in applications such as GPS (global positioning system) screen in cars.

To facilitate easy pick and place assembly, the LEDs are packed in EIA-compliant tape and reel. Every reel is shipped in single intensity and color bin, to provide close uniformity.

These LEDs are compatible with IR solder reflow process.

### Features

- Industry-standard PLCC-4
- High reliability LED package
- Long life, up to 50,000 hours at 25°C
- High brightness using InGaN dice technologies
- High optical efficiency
- Super wide viewing angle at 120°
- Tight white color binning: 8 bins
- Available is 8-mm carrier tape on 7-inch reel
- Stable and consistent performance with minimum degradation with silicone encapsulation
- JEDEC MSL 2a

### Applications

- Interior and exterior automotive
  - Instrument panel backlighting
  - Central console backlighting
  - Navigation and audio system backlighting
  - Dome/Map lighting
  - Push button backlighting
  - Number plate illumination
  - Rear reverse lamp indicator
- Electronic signs and signals
  - Decorative lighting
- Office automation, home appliances, industrial equipment
  - Front panel backlighting
  - Push button backlighting

**CAUTION!** HSMW-A40x-xxxxx LEDs are Class 2 ESD sensitive. Please observe appropriate precautions during handling and processing. Refer to Application Note AN-1142 for additional details.

## Package Drawing

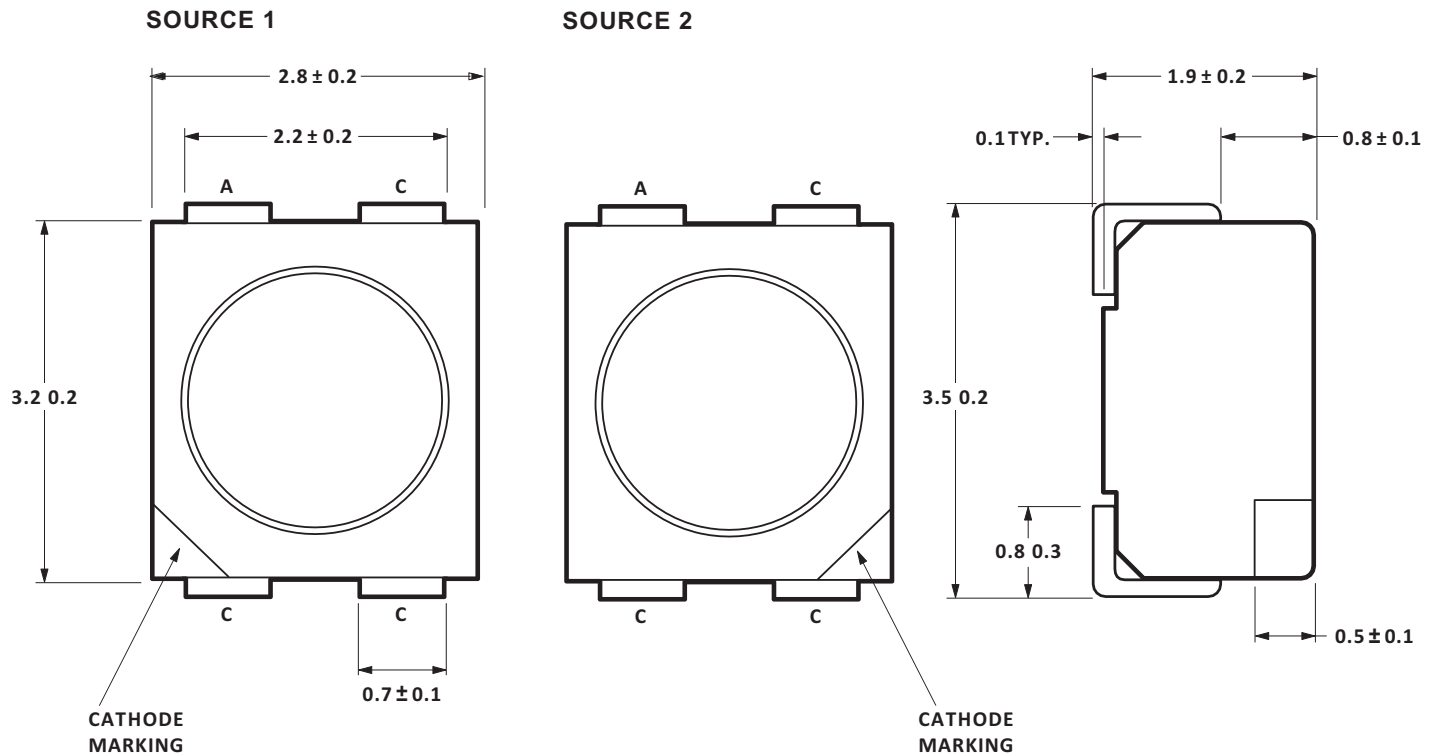

### NOTE:

1. All dimensions in millimeters (mm).
2. Tolerance is  $\pm 0.20$  mm unless otherwise specified.
3. Encapsulation = silicone.
4. Terminal finish = silver plating.

## Device Selection Guide

Color	Part Number	Luminous Intensity, $I_V$ (mcd) <sup>a, b</sup>			Test Current (mA)	Dice Technology
		Min.	Typ.	Max.		
White	ASMT-SWBM-NU803	560.00	1100.00	1400.00	30	InGaN
White	ASMT-SWBM-NV803	900.00	—	2240.00	30	InGaN

a. The luminous intensity,  $I_V$ , is measured at the mechanical axis of the lamp package. The actual peak of the spatial radiation pattern may not be aligned with this axis.

b.  $I_V$  tolerance  $\pm 12\%$ .

## Part Numbering System

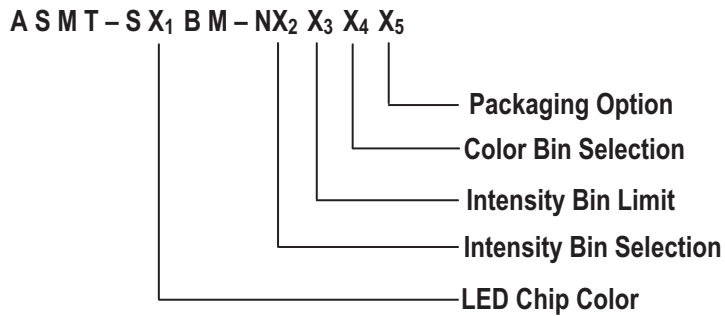

## Absolute Maximum Ratings ( $T_A = 25^\circ\text{C}$ )

Parameters	ASMT-SWBM-Nxxxx
DC Forward Current <sup>a</sup>	50 mA
Peak Forward Current <sup>b</sup>	300 mA
Power Dissipation	215 mW
Reverse Voltage	4V
Junction Temperature	125°C
Operating Temperature	-40°C to +100°C
Storage Temperature	-40°C to +100°C

a. Derate linearly as shown in [Figure 4](#).

b. Duty factor = 0.5%, Frequency = 500 Hz.

## Optical Characteristics ( $T_A = 25^\circ\text{C}$ )

Color	Part Number	Dice Technology	Typical Chromaticity Coordinates <sup>a</sup>		Viewing Angle $2\theta_{1/2}$ <sup>b</sup> (Degrees)	Luminous Efficacy $\eta_e$ (lm/W)	Total Flux <sup>c</sup> / Luminous Intensity $\Phi_V$ (lm)/ $I_V$ (cd)
			x	y	Typ.	Typ.	Typ.
White	ASMT-SWBM-Nxxxx	InGaN	0.318	0.318	120	27	2.7

a. The chromaticity coordinates are derived from the CIE 1931 Chromaticity Diagram and represent the perceived color of the device.

b.  $\theta_{1/2}$  is the off-axis angle where the luminous intensity is  $1/2$  the peak intensity.

c.  $\Phi_V$  is the total luminous flux output as measured with an integrating sphere at mono pulse conditions.  $\Phi$

## Electrical Characteristics ( $T_A = 25^\circ\text{C}$ )

Part Number	Forward Voltage $V_F$ (Volts) at $I_F = 30 \text{ mA}^a$		Reverse Voltage $V_R$ at $10 \mu\text{A}$	Thermal Resistance $R\theta_{J-P}$ ( $^\circ\text{C}/\text{W}$ )
	Typ.	Max.	Min.	
ASMT-SWBM-Nxxxx	3.2	3.8	4	110

a. Tolerance =  $\pm 0.1\text{V}$ .

## Targeted Mean Lifetime

Conditions	Mean Luminous Maintenance (L50)	Unit
$I_F = 25 \text{ mA}$ , $T_A = 85^\circ\text{C}$	25,000	Operating hours
$I_F = 25 \text{ mA}$ , $T_A = 25^\circ\text{C}$	50,000	Operating hours

### Notes:

The typical data or calculated correlations can only reflect statistical figures; hence they can be used for reference only.

All data shown is based on Thermal Resistance  $R\theta_{J-A} = 300^\circ\text{C}/\text{W}$ .

Due to technical improvements, Broadcom reserves right to change the typical data without any further notice.

Figure 1: Relative Intensity vs. Wavelength

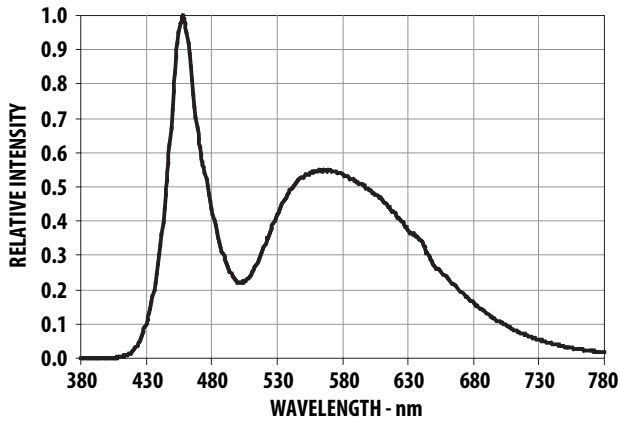

Figure 2: Forward Current vs. Forward Voltage

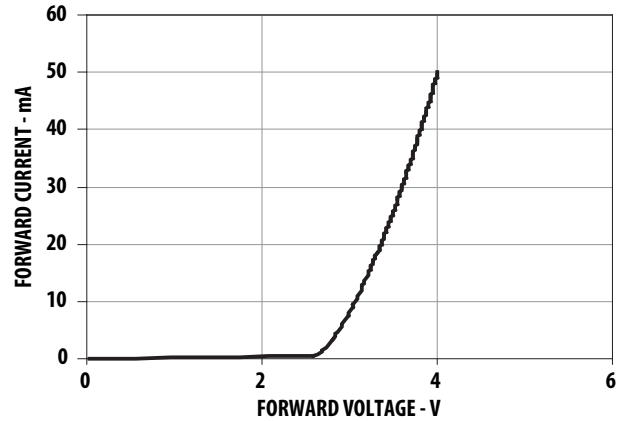

Figure 3: Relative Intensity vs. Forward Current

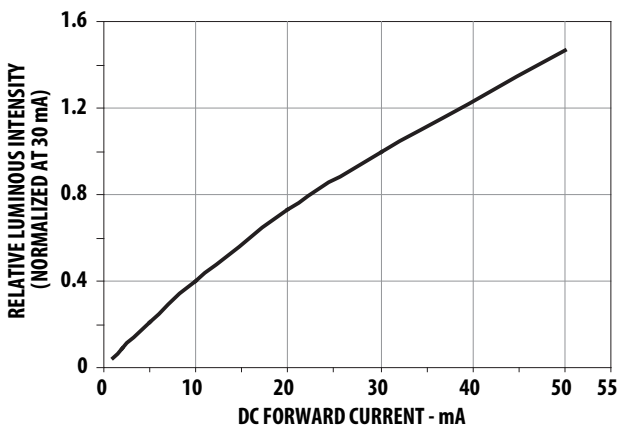

Figure 4: Maximum Forward Current vs. Ambient Temperature, Derated Based on  $T_{JMAX}=125^{\circ}C$ ,  $R_{\theta J-A}=300^{\circ}C/W$

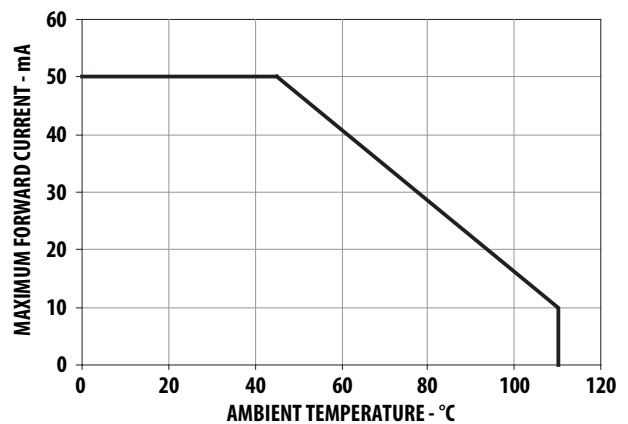

Figure 5: Maximum Forward Current vs. Solder Point Temperature, Derated Based on  $T_{JMAX}=125^{\circ}C$ ,  $R_{\theta J-A}=110^{\circ}C/W$

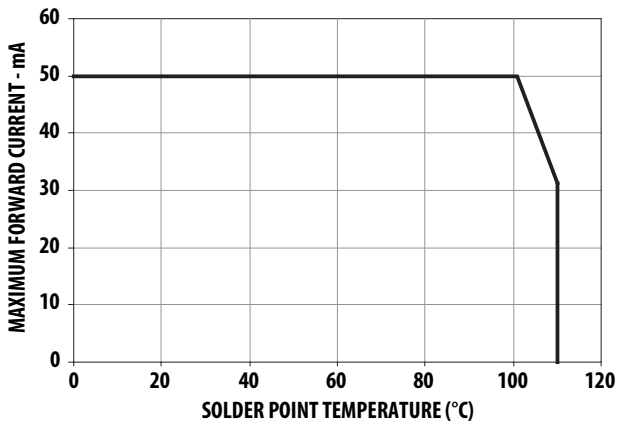

Figure 6: Radiation Pattern

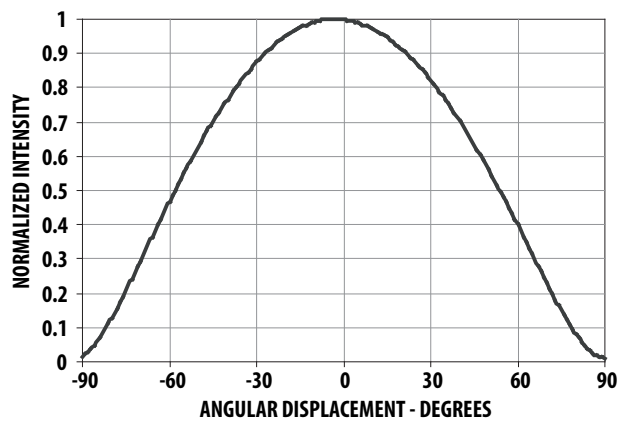

Figure 7: Recommended Pick and Place Nozzle Size

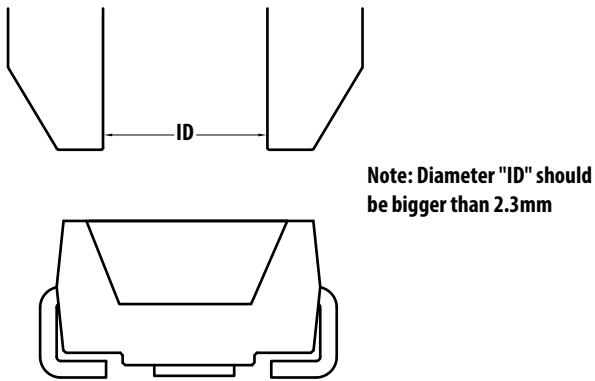

Figure 8: Recommended Pb-Free Reflow Soldering Profile

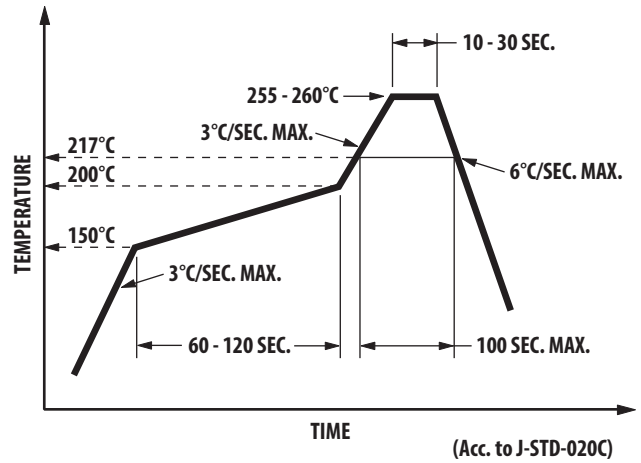

Figure 9: Recommended Soldering Pad Pattern

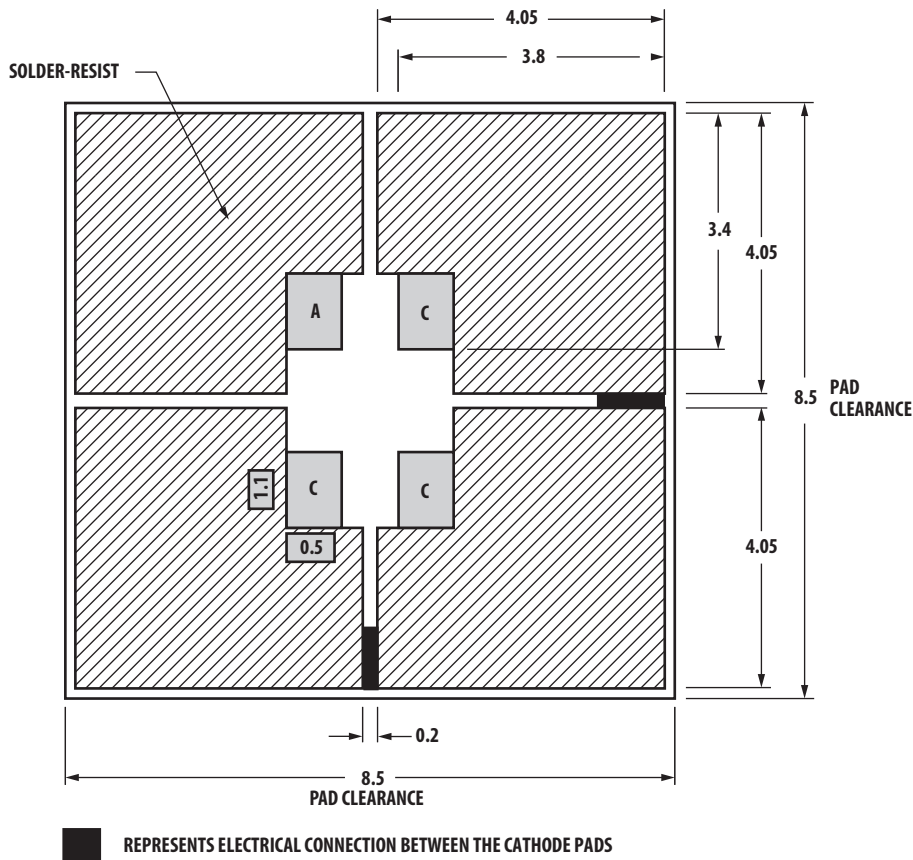

Figure 10: Tape Leader and Trailer Dimensions

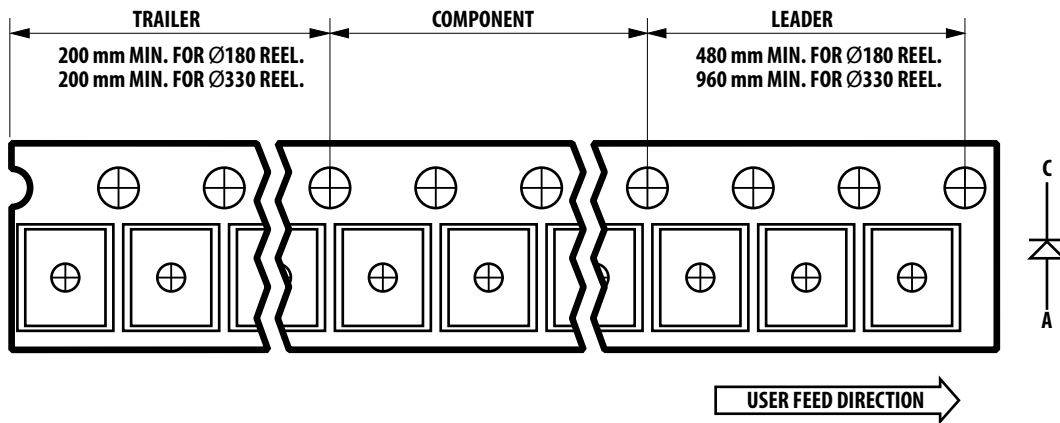

Figure 11: Tape Dimensions

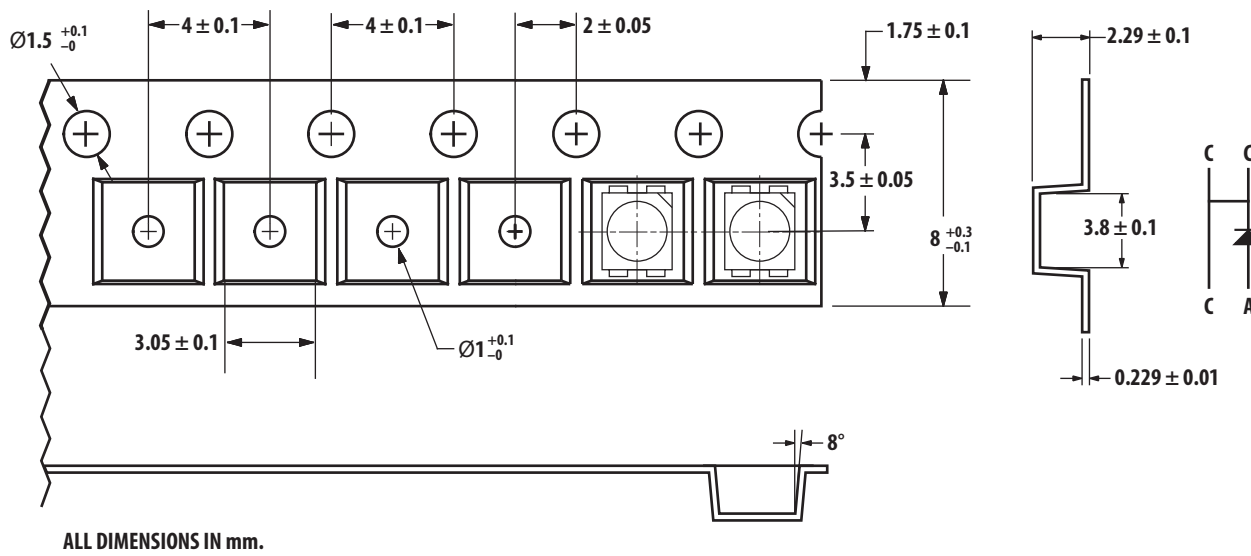
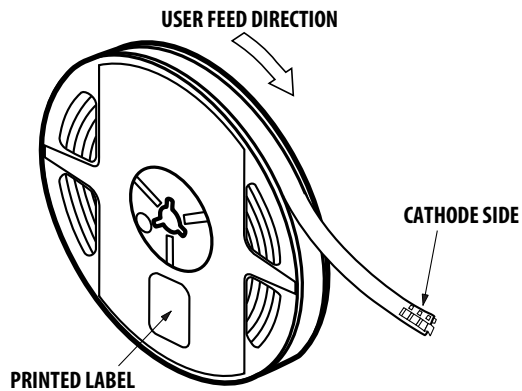

Figure 12: Reeling Orientation



# Precautionary Notes

## Soldering

- Do not perform reflow soldering more than twice. Observe necessary precautions of handling moisture-sensitive device as stated in the following section.
- Do not apply any pressure or force on the LED during reflow and after reflow when the LED is still hot.
- Use reflow soldering to solder the LED. Use hand soldering only for rework if unavoidable, but it must be strictly controlled to following conditions:
  - Soldering iron tip temperature = 315°C max.
  - Soldering duration = 3 sec max.
  - Number of cycles = 1 only.
  - Power of soldering iron = 50W max.
- Do not touch the LED package body with the soldering iron except for the soldering terminals, as it can cause damage to the LED.
- Confirm beforehand whether the functionality and performance of the LED is affected by soldering with hand soldering.

Figure 13: Recommended Lead-Free Reflow Soldering Profile

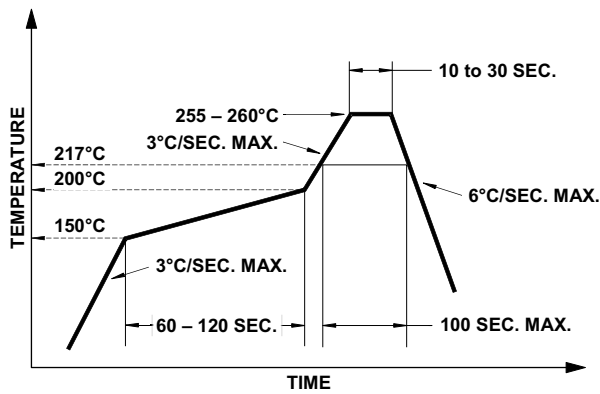
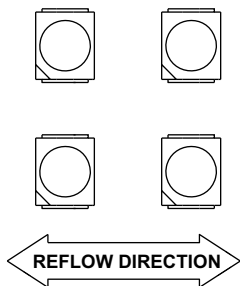

Figure 14: Recommended Board Reflow Direction



# Handling Precautions

The encapsulation material of the LED is made of silicone for better product reliability. Compared to epoxy encapsulant that is hard and brittle, silicone is softer and flexible. Observe special handling precautions during assembly of silicone encapsulated LED products. Failure to comply might lead to damage and premature failure of the LED. Refer to Application Note AN5288, *Silicone Encapsulation for LED: Advantages and Handling Precautions*, for additional information.

- Do not poke sharp objects into the silicone encapsulant. Sharp objects, such as tweezers or syringes, might apply excessive force or even pierce through the silicone and induce failures to the LED die or wire bond.
- Do not touch the silicone encapsulant. Uncontrolled force acting on the silicone encapsulant might result in excessive stress on the wire bond. Hold the LED only by the body.
- Do not stack assembled PCBs together. Use an appropriate rack to hold the PCBs.
- The surface of the silicone material attracts dust and dirt easier than epoxy due to its surface tackiness. To remove foreign particles on the surface of silicone, use a cotton bud with isopropyl alcohol (IPA). During cleaning, rub the surface gently without putting too much pressure on the silicone. Ultrasonic cleaning is not recommended.
- For automated pick and place, Broadcom has tested the following nozzle size with OD 1.5 mm to work with this LED. However, due to the possibility of variations in other parameters, such as pick and place machine maker/model and other settings of the machine, verify that the nozzle selected will not cause damage to the LED.

# Handling of Moisture-Sensitive Devices

This product has a Moisture Sensitive Level 3 rating per JEDEC J-STD-020. Refer to Application Note AN5305, *Handling of Moisture Sensitive Surface Mount Devices*, for additional details and a review of proper handling procedures.

- **Before use:**
  - An unopened moisture barrier bag (MBB) can be stored at <40°C/90% RH for 12 months. If the actual shelf life has exceeded 12 months and the humidity indicator card (HIC) indicates that baking is not required, it is safe to reflow the LEDs per the original MSL rating.



- Do not open the MBB prior to assembly (for example, for IQC). If unavoidable, MBB must be properly resealed with fresh desiccant and HIC. The exposed duration must be taken in as floor life.
- **Control after opening the MBB:**
  - Read the HIC immediately upon opening the MBB.
  - Keep the LEDs at <30°C/60% RH at all times, and complete all high temperature-related processes, including soldering, curing, or rework within 168 hours.
- **Control for unfinished reel:**  
Store unused LEDs in a sealed MBB with desiccant or desiccator at <5% RH.
- **Control of assembled boards:**  
If the PCB soldered with the LEDs is to be subjected to other high-temperature processes, store the PCB in a sealed MBB with desiccant or desiccator at <5% RH to ensure that all LEDs have not exceeded their floor life of 168 hours.
- **Baking is required if the following conditions exist:**
  - The HIC indicator indicates a change in color for 10% and 5%, as stated on the HIC.
  - The LEDs are exposed to conditions of >30°C/60% RH at any time.
  - The LED floor life exceeded 168 hours.

The recommended baking condition is 60°C ± 5°C for 20 hours.

Baking can only be done once.
- **Storage:**  
The soldering terminals of these Broadcom LEDs are silver plated. If the LEDs are exposed in ambient environment for too long, the silver plating might be oxidized, thus affecting its solderability performance. As such, keep unused LEDs in a sealed MBB with desiccant or in desiccator at <5% RH.

## Application Precautions

- The drive current of the LED must not exceed the maximum allowable limit across temperature as stated in the data sheet. Constant current driving is recommended to ensure consistent performance.
- Circuit design must cater to the whole range of forward voltage ( $V_F$ ) of the LEDs to ensure the intended drive current can always be achieved.
- The LED exhibits slightly different characteristics at different drive currents, which might result in larger variation of performance (meaning intensity,

wavelength, and forward voltage). Set the application current as close as possible to the test current to minimize these variations.

- Do not use the LED in the vicinity of material with sulfur content, or in environments of high gaseous sulfur compounds and corrosive elements. Examples of material that might contain sulfur are rubber gaskets, room-temperature vulcanizing (RTV) silicone rubber, rubber gloves, and so on. Prolonged exposure to such environments can affect the optical characteristics and product life.
- White LEDs must not be exposed to acidic environments and must not be used in the vicinity of any compound that might have acidic outgas, such as, but not limited to, acrylate adhesive. These environments have an adverse effect on LED performance.
- Avoid rapid change in ambient temperatures, especially in high-humidity environments, because this causes condensation on the LED.
- If the LED is intended to be used in outdoor or harsh environments, protect the LED against damages caused by rain water, water, dust, oil, corrosive gases, external mechanical stress, and so on.

## Thermal Management

The optical, electrical, and reliability characteristics of the LED are affected by temperature. Keep the junction temperature ( $T_J$ ) of the LED below the allowable limit at all times.  $T_J$  can be calculated as below:

$$T_J = T_A + R_{\theta J-A} \times I_F \times V_{Fmax}$$

where:

$T_A$  = Ambient temperature (°C)

$R_{\theta J-A}$  = Thermal resistance from LED junction to ambient (°C/W)

$I_F$  = Forward current (A)

$V_{Fmax}$  = Maximum forward voltage (V)

The complication of using this formula lies in  $T_A$  and  $R_{\theta J-A}$ . Actual  $T_A$  is sometimes subjective and hard to determine.  $R_{\theta J-A}$  varies from system to system depending on design and is usually not known.

Another way of calculating  $T_J$  is by using solder point temperature  $T_S$  as follows:

$$T_J = T_S + R_{\theta J-S} \times I_F \times V_{Fmax}$$

where:

$T_S$  = LED solder point temperature as shown in the following figure ( $^{\circ}\text{C}$ )

$R_{\theta_{J-S}}$  = Thermal resistance from junction to solder point ( $^{\circ}\text{C}/\text{W}$ )

$I_F$  = Forward current (A)

$V_{Fmax}$  = Maximum forward voltage (V)

**Figure 15: Solder Point Temperature on PCB**

Source 1

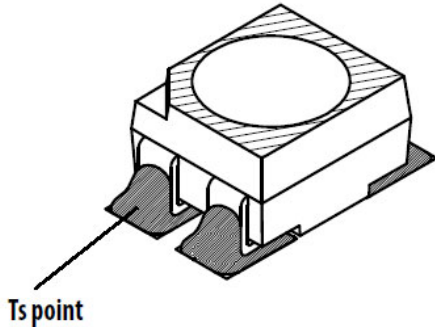

Source 2

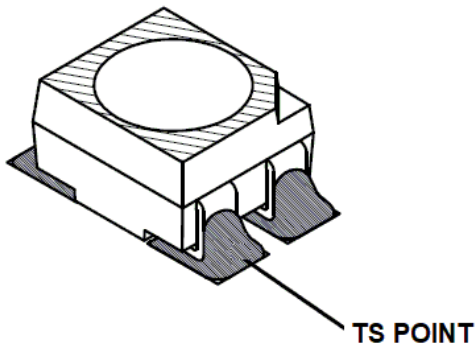

$T_S$  can be measured easily by mounting a thermocouple on the soldering joint as shown in the preceding figure, while  $R_{\theta_{J-S}}$  is provided in the data sheet. Verify the  $T_S$  of the LED in the final product to ensure that the LEDs are operating within all maximum ratings stated in the data sheet.

## Bin Information

### Intensity Bin Select ( $X_2X_3$ )

Individual reel will contain parts from one half bin only.

$X_2$	Min. $I_V$ Bin
$X_3$	
0	Full Distribution
2	2 half bins starting from $X_21$
3	3 half bins starting from $X_21$
4	4 half bins starting from $X_21$
5	5 half bins starting from $X_21$
6	2 half bins starting from $X_22$
7	3 half bins starting from $X_22$
8	4 half bins starting from $X_22$
9	5 half bins starting from $X_22$

### Intensity Bin Limits

Bin ID	Min. (mcd)	Max. (mcd)
N1	28.50	35.50
N2	35.50	45.00
P1	45.00	56.00
P2	56.00	71.50
Q1	71.50	90.00
Q2	90.00	112.50
R1	112.50	140.00
R2	140.00	180.00
S1	180.00	224.00
S2	224.00	285.00
T1	285.00	355.00
T2	355.00	450.00
U1	450.00	560.00
U2	560.00	715.00
V1	715.00	900.00
V2	900.00	1125.00
W1	1125.00	1400.00
W2	1400.00	1800.00

Tolerance of each bin limit =  $\pm 12\%$ .

## Color Bin Select ( $X_4$ )

Individual reel will contain parts from one full bin only.

$X_4$	
0	Full Distribution
A	1 and 2 only
B	2 and 3 only
C	3 and 4 only
D	4 and 5 only
E	5 and 6 only
F	6 and 7 only
G	1, 2, and 3 only
H	2, 3, and 4 only
J	3, 4, and 5 only
K	4, 5, and 6 only
L	5, 6, and 7 only
M	1, 2, 3, and 4 only
N	2, 3, 4, and 5 only
P	3, 4, 5, and 6 only
Q	4, 5, 6, and 7 only
R	1, 2, 3, 4, and 5 only
S	2, 3, 4, 5, and 6 only
T	3, 4, 5, 6, and 7 only
U	1, 2, 3, 4, 5, and 6 only
V	2, 3, 4, 5, 6, and 7 only
Z	Special Color Bin

### Color Bin Limits

Bin ID	Limits (Chromaticity Coordinates)				
		x	y	z	w
1	x	0.296	0.291	0.310	0.313
	y	0.259	0.268	0.297	0.284
2	x	0.291	0.285	0.307	0.310
	y	0.268	0.279	0.312	0.297
3	x	0.313	0.310	0.330	0.330
	y	0.284	0.297	0.330	0.310
4	x	0.310	0.307	0.330	0.330
	y	0.297	0.312	0.347	0.330
5	x	0.330	0.330	0.338	0.352
	y	0.310	0.330	0.342	0.344
6	x	0.330	0.330	0.347	0.345
	y	0.330	0.347	0.371	0.352
7	x	0.352	0.338	0.364	0.360
	y	0.344	0.342	0.380	0.357
8	x	0.345	0.347	0.367	0.364
	y	0.352	0.371	0.401	0.380

Tolerance of each bin limit =  $\pm 0.02$ .

## Packaging Option (X<sub>5</sub>)

Option	Test Current	Package Type	Reel Size
3	30 mA	Top Mount	7 inch

## V<sub>F</sub> Bin Limits

Bin ID	Min.	Max.
S2	2.60	3.20
S3	3.20	3.80

Tolerance of each bin limit =  $\pm 0.1V$ .

## Color Coordinates Chart

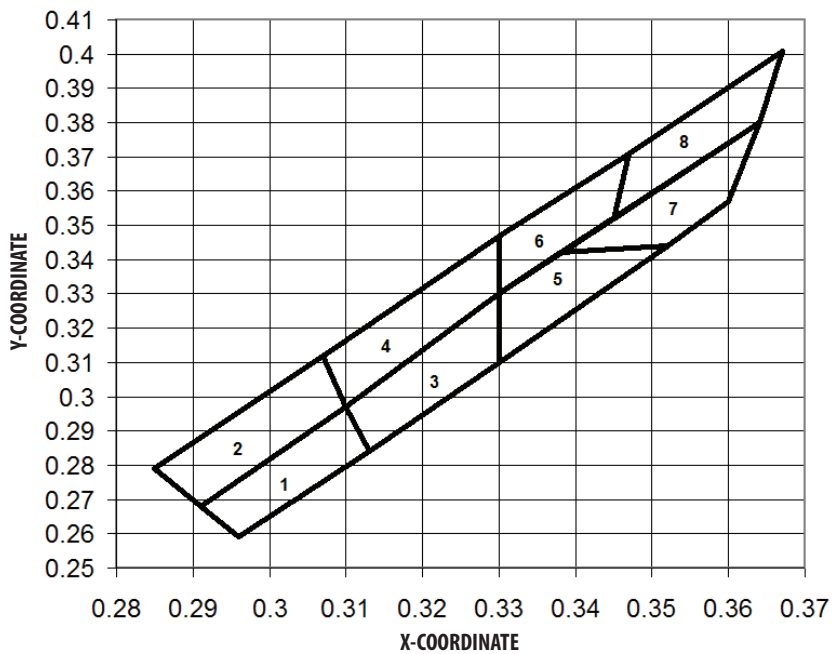

Broadcom, the pulse logo, Connecting everything, Avago Technologies, Avago, and the A logo are among the trademarks of Broadcom and/or its affiliates in the United States, certain other countries, and/or the EU.

Copyright © 2005–2019 Broadcom. All Rights Reserved.

The term “Broadcom” refers to Broadcom Inc. and/or its subsidiaries. For more information, please visit [www.broadcom.com](http://www.broadcom.com).

Broadcom reserves the right to make changes without further notice to any products or data herein to improve reliability, function, or design. Information furnished by Broadcom is believed to be accurate and reliable. However, Broadcom does not assume any liability arising out of the application or use of this information, nor the application or use of any product or circuit described herein, neither does it convey any license under its patent rights nor the rights of others.



Lead (Pb) Free  
RoHS 6 fully  
compliant