

# ASSR-1218, ASSR-1219, and ASSR-1228

## Form A, Solid State Relay (Photo MOSFET) (60V/0.2A/10Ω)

### Description

The Broadcom<sup>®</sup> ASSR-12XX Series consists of an AlGaAs infrared light-emitting diode (LED) input stage that is optically coupled to a high-voltage output detector circuit. The detector consists of a high-speed photovoltaic diode array and driver circuitry to switch on/off two discrete high-voltage MOSFETs. The relay turns on (contact closes) with a minimum input current of 3 mA through the input LED. The relay turns off (contact opens) with an input voltage of 0.8V or less.

The single channel configurations, ASSR-1218 and ASSR-1219, are equivalent to 1 Form A Electromechanical Relays (EMR), and the dual-channel configuration, ASSR-1228, is equivalent to 2 Form A EMR. They are available in 4-pin SO, 6-pin DIP, 8-pin DIP, and gull wing surface mount for DIP packages.

ASSR-1219 enables AC/DC and DC-only output connections. For DC-only connection, the output current,  $I_O$ , increases to 0.4A and the On-Resistance,  $R_{(ON)}$  reduces to 2.5Ω.

### Features

- Compact solid-state bidirectional signal switch
- Single and dual-channel normally-off Single-Pole-Single-Throw (SPST) relay
- 60V output withstand voltage
- 0.2A or 0.4A current rating
  - See schematics for ASSR-1219 Connection A and Connection B
- Low input current: CMOS compatibility
- Low On-Resistance
  - 0.25Ω typical for DC-only
  - 1Ω typical for AC/DC
- High input-to-output insulation voltage (safety and regulatory approved)
  - 3750 V<sub>rms</sub> for 1 minute per UL1577
  - CSA Component Acceptance

### Applications

- Telecommunications switching
- Data communications
- Industrial controls
- Medical systems
- Security systems
- EMR/Reed Relay replacement

**CAUTION!** It is advised that normal static precautions be taken in handling and assembly of this component to prevent damage and degradation which may be induced by ESD.

The components featured in this data sheet are not to be used in military or aerospace applications or environments. The components are not AEC-Q100 qualified and are not recommended for automotive applications.

## Functional Diagram

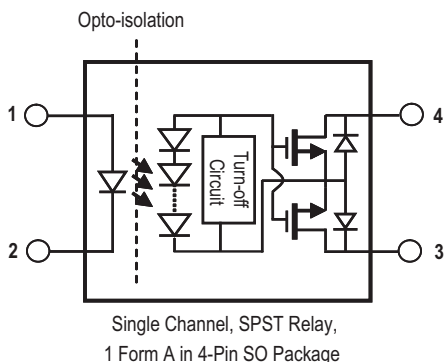

## Truth Table

LED	Output
Off	Open
On	Close

## Ordering Information

ASSR-xxx is UL Recognized with 3750 V<sub>rms</sub> for 1 minute per UL1577 and is approved under CSA Component Acceptance Notice #5.

Part Number	Option	Package	Surface Mount	Gull Wing	Tape and Reel	Quantity
	RoHS Compliant					
ASSR-1218	-003E	SO-4	X	—	—	100 units per tube
	-503E		X	—	X	1500 units per reel
ASSR-1219	-001E	300-mil	—	—	—	50 units per tube
	-301E	DIP-6	X	X	—	50 units per tube
	-501E		X	X	X	1000 units per reel
ASSR-1228	-002E	300-mil	—	—	—	50 units per tube
	-302E	DIP-8	X	X	—	50 units per tube
	-502E		X	X	X	1000 units per reel

To order, choose a part number from the Part Number column and combine it with the desired option from the Option column to form an order entry.

**Example:** Select ASSR-1219-501E to order the product consisting of a 300-mil DIP-6 gull wing surface mount package in tape and reel packaging that is RoHS compliant.

**Example:** Select ASSR-1228-002E to order the product consisting of a 300-mil DIP-8 package in tube packaging that is RoHS compliant.

Option data sheets are available. Contact your Broadcom sales representative or authorized distributor for information.

# Schematics

## ASSR-1218

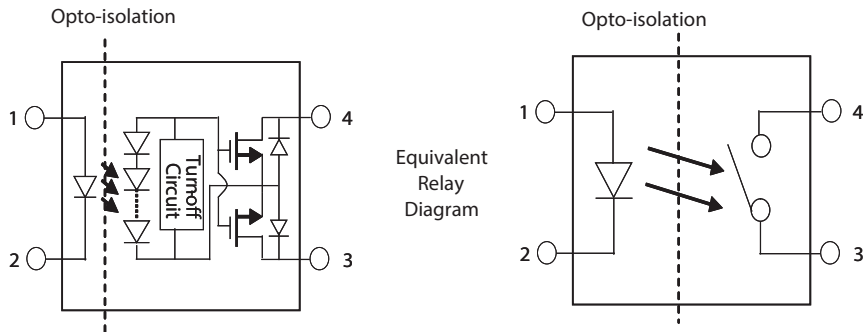

## ASSR-1219 Connection A

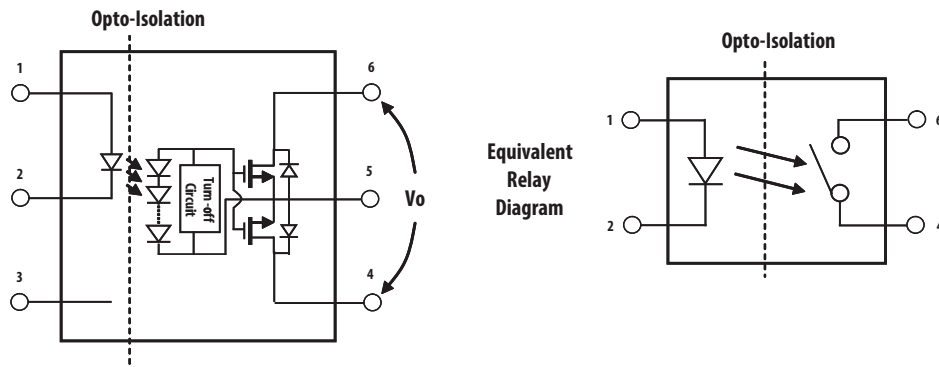

## ASSR-1219 Connection B

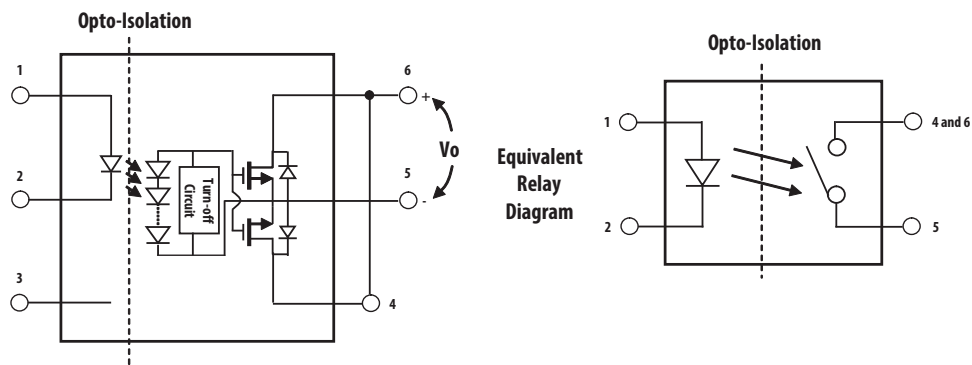

# ASSR-1228

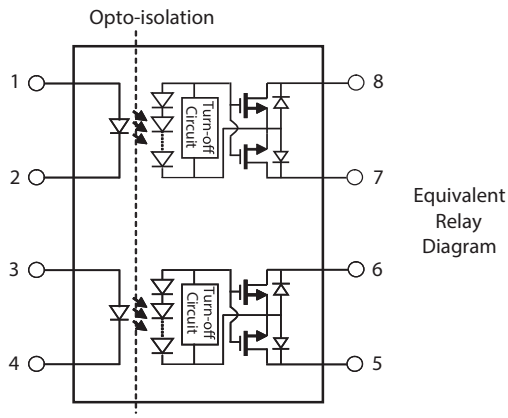

Equivalent Relay Diagram

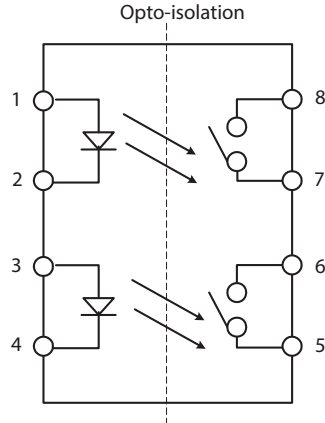

## Package Outline Drawings

### ASSR-1218 4-Pin Small Outline Package

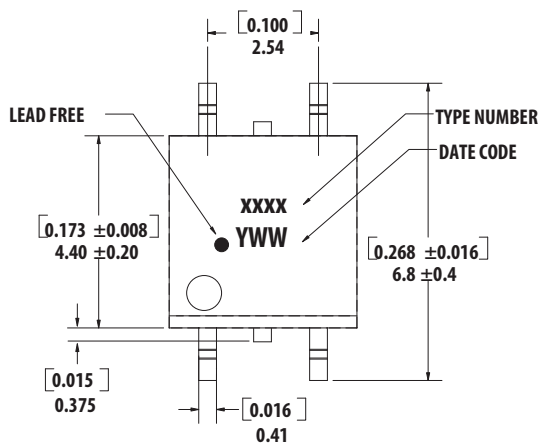

#### LAND PATTERN RECOMMENDATION

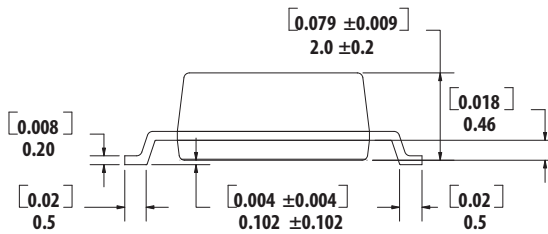
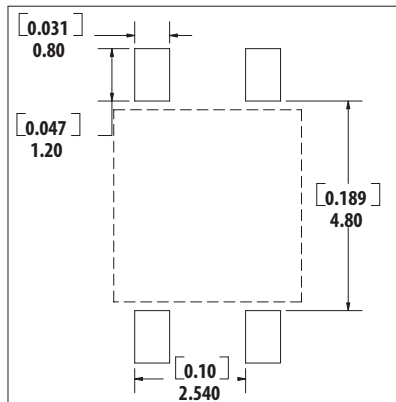

DIMENSIONS IN MILLIMETERS AND [INCHES]  
OPTION NUMBER 500 AND UL RECOGNITION NOT MARKED

# ASSR-1219 6-Pin DIP Package

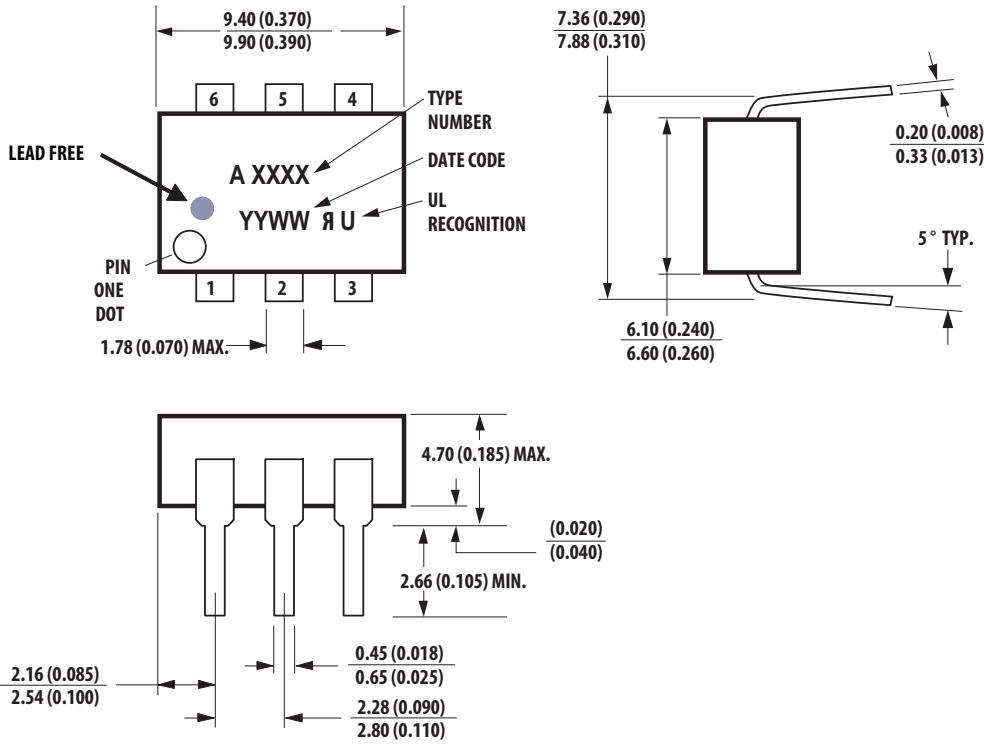

DIMENSIONS IN MILLIMETERS AND (INCHES).

# ASSR-1219 6-Pin DIP Package with Gull Wing Surface Mount Option 300

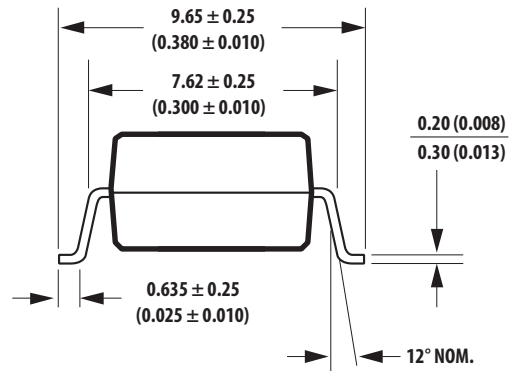
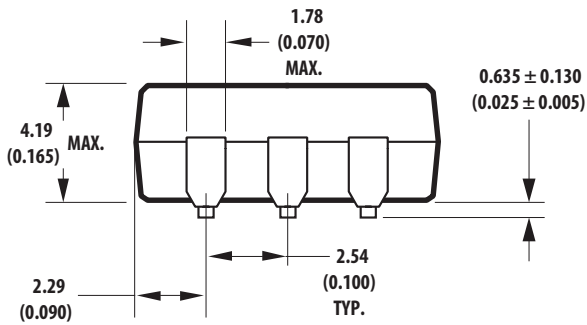
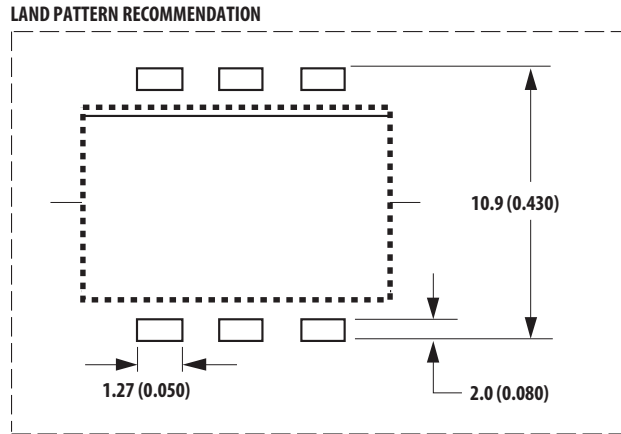
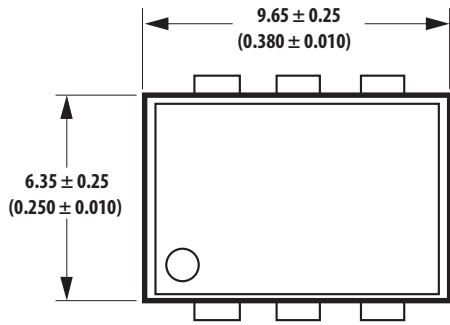

NOTE: FLOATING LEAD PROTRUSION IS 0.25 mm (10 mils) MAX.

# ASSR-1228 8-Pin DIP Package

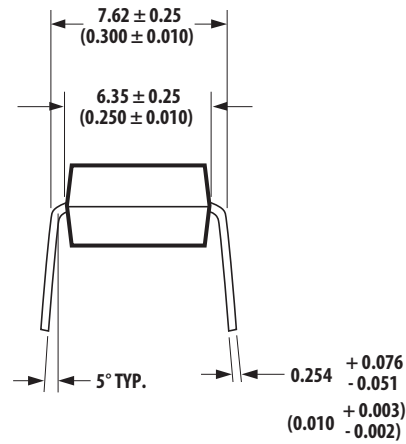
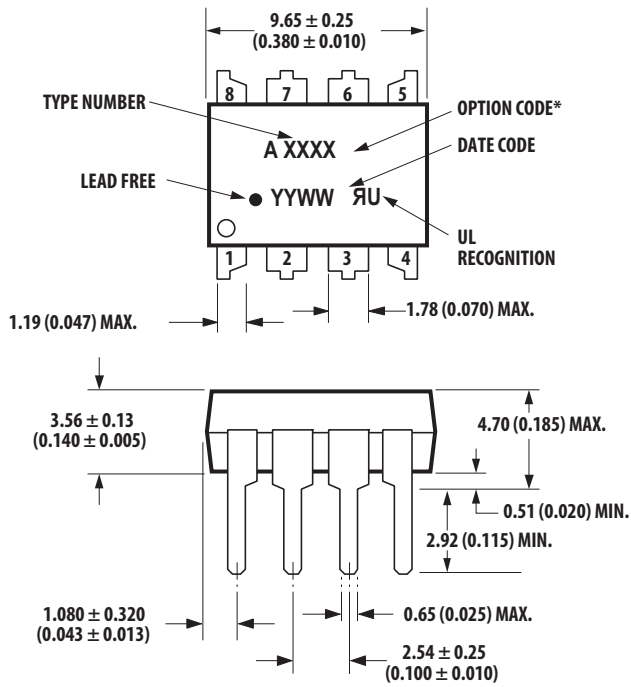

DIMENSIONS IN MILLIMETERS AND (INCHES).  
OPTION NUMBERS 300 AND 500 NOT MARKED.

## ASSR-1219 6-Pin DIP Package with Gull Wing Surface Mount Option 300

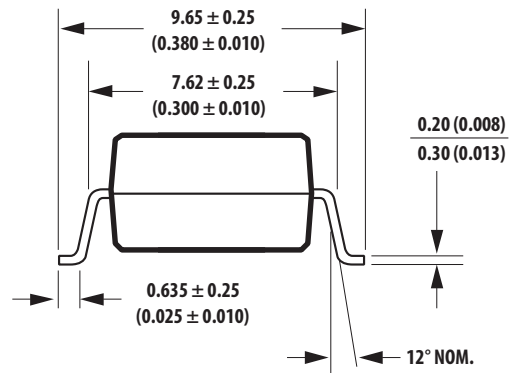
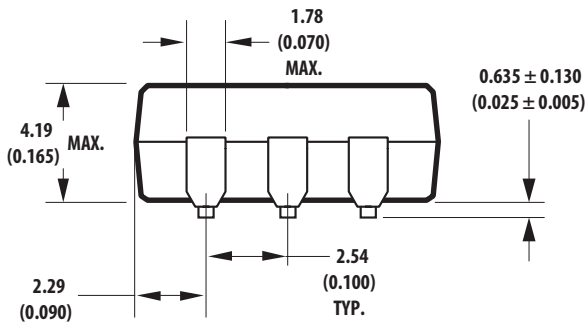
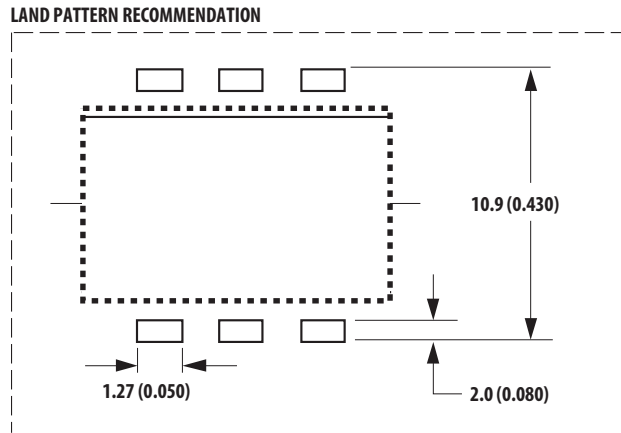
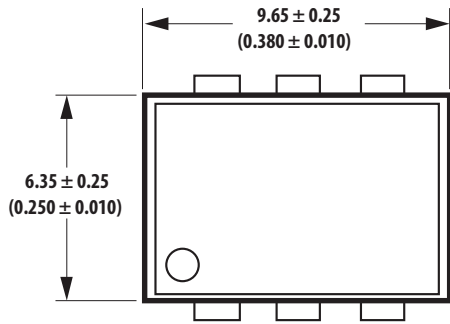

NOTE: FLOATING LEAD PROTRUSION IS 0.25 mm (10 mils) MAX.



## Solder Reflow Profile

The recommended reflow soldering conditions are per JEDEC Standard J-STD-020 (latest revision). Use non-halide flux.

## Regulatory Information

The ASSR-1218, ASSR-1219, and ASSR-1228 are approved by the following organizations:

UL	Approval under UL 1577, component recognition program up to $V_{ISO} = 3750 V_{rms}$ .
CSA	Approval under CSA Component Acceptance Notice #5.

## Insulation-Related and Safety-Related Specifications

Parameter	Symbol	ASSR-1218	ASSR-1219 ASSR-1228	Unit	Conditions
Minimum External Air Gap (Clearance)	L(101)	4.9	7.1	mm	Measured from input terminals to output terminals, shortest distance through air.
Minimum External Tracking (Creepage)	L(102)	4.9	7.4	mm	Measured from input terminals to output terminals, shortest distance path along body.
Minimum Internal Plastic Gap (Internal Clearance)	—	0.08	0.08	mm	Through insulation distance conductor to conductor, usually the straight line distance thickness between the emitter and detector.
Tracking Resistance (Comparative Tracking Index)	CTI	175	175	V	DIN IEC 112/VDE 0303 Part 1.
Isolation Group (DIN VDE0109)	—	IIIa	IIIa	—	Material Group (DIN VDE 0109).

## Absolute Maximum Ratings

Parameter	Symbol	Min.	Max.	Unit	Note
Storage Temperature	$T_S$	-55	125	°C	
Operating Temperature	$T_A$	-40	85	°C	
Junction Temperature	$T_J$	—	125	°C	
Lead Soldering Cycle	Temperature	—	260	°C	
	Time	—	10	s	
Input Current	Average	—	25	mA	
	Surge	—	50		
	Transient	—	1000		
Reversed Input Voltage	$V_R$	—	5	V	
Input Power Dissipation	ASSR-1218	$P_{IN}$	—	40	mW
	ASSR-1219	$P_{IN}$	—	40	mW
	ASSR-1228	$P_{IN}$	—	80	mW
Output Power Dissipation	ASSR-1218	$P_O$	—	400	mW
	ASSR-1219	$P_O$	—	400	mW
	ASSR-1228	$P_O$	—	800	mW

Parameter	Symbol	Min.	Max.	Unit	Note
Average Output Current ( $T_A = 25^\circ\text{C}$ , $T_C \leq 100^\circ\text{C}$ )	$I_O$	—	0.20	A	a
	ASSR-1219 Connection B	$I_O$	—	0.40	A
Output Voltage ( $T_A = 25^\circ\text{C}$ )	$V_O$	-60	60	V	b
	ASSR-1219 Connection B	$V_O$	0	60	V
Solder Reflow Temperature Profile	See <a href="#">Solder Reflow Profile</a> .				

- a. For derating, refer to [Figure 1](#), [Figure 2](#), [Figure 3](#), and [Figure 4](#).
- b. The voltage across the output terminals of the relay should not exceed this rated withstand voltage. Overvoltage protection circuits should be added in some applications to protect against overvoltage transients.

## Recommended Operating Conditions

Parameter	Symbol	Min.	Max.	Unit	Note
Input Current (ON)	$I_{F(\text{ON})}$	3	20	mA	a
Input Voltage (OFF)	$V_{F(\text{OFF})}$	0	0.8	V	
Operating Temperature	$T_A$	-40	+85	$^\circ\text{C}$	

- a. Threshold to switch device is  $I_F \geq 0.5$  mA, however, for qualified device performance over temperature range, it is recommended to operate at  $I_F = 5$  mA.

## Package Characteristics

Unless otherwise specified,  $T_A = 25^\circ\text{C}$ .

Parameter	Symbol	Min.	Typ.	Max.	Unit	Conditions	Note	
Input-Output Momentary Withstand Voltage	$V_{ISO}$	3750	—	—	$V_{rms}$	$RH \leq 50\%$ , $t = 1$ minute	a, b	
Input-Output Resistance	$R_{I-O}$	—	$10^{12}$	—	$\Omega$	$V_{I-O} = 500$ Vdc		
Input-Output Capacitance	ASSR-1218	$C_{I-O}$	—	0.4	—	pF	$V_{I-O} = 0$ Vdc, $f = 1$ MHz	a
	ASSR-1219	$C_{I-O}$	—	0.5	—	pF	$V_{I-O} = 0$ Vdc, $f = 1$ MHz	
	ASSR-1228	$C_{I-O}$	—	0.8	—	pF	$V_{I-O} = 0$ Vdc, $f = 1$ MHz	

- a. Device is considered a two-terminal device: ASSR-1218: pin 1, 2 shorted and pin 3, 4 shorted; ASSR-1219: pin 1, 2, 3 shorted and pin 4, 5, 6 shorted, ASSR-1228: pin 1, 2, 3, 4 shorted and pin 5, 6, 7, 8 shorted.
- b. The Input-Output Momentary Withstand Voltage is a dielectric voltage rating that should not be interpreted as an input-output continuous voltage rating. For the continuous voltage rating, refer to the IEC/EN/DIN EN 60747-5-2 Insulation Characteristics Table (if applicable), your equipment level safety specification, or Broadcom Application Note 1074, *Optocoupler Input-Output Endurance Voltage*.

## Electrical Specifications (DC)

For operating  $T_A = +25^\circ\text{C}$ .

Parameter	Symbol	Min.	Typ.	Max.	Unit	Conditions	Fig.	Note	
Output Withstand Voltage	$ V_{O(OFF)} $	60	65	—	V	$V_F = 0.8\text{V}$ , $I_O = 250 \mu\text{A}$	5		
Output Leakage Current	$I_{O(OFF)}$	—	—	1	$\mu\text{A}$	$V_F = 0.8\text{V}$ , $V_O = 60\text{V}$			
Input Reverse Breakdown Voltage	$V_R$	5	—	—	V	$I_R = 10 \mu\text{A}$			
Input Forward Voltage	$V_F$	1.1	1.3	1.6	V	$I_F = 5$ mA	6, 7		
Output On-Resistance		$R_{(ON)}$	—	0.2	10	$\Omega$	$I_F = 5$ mA, $I_O = 200$ mA, Pulse $\leq 30$ ms	8, 9	a
	ASSR-1219 Connection B		—	0.1	2.5	$\Omega$	$I_F = 5$ mA, $I_O = 400$ mA, Pulse $\leq 30$ ms		

- a. During the pulsed  $R_{(ON)}$  measurement ( $I_O$  duration  $\leq 30$  ms), ambient ( $T_A$ ) and case temperature ( $T_C$ ) are equal.

## Switching Specifications (AC)

For operating  $T_A = +25^\circ\text{C}$ .

Parameter	Symbol	Min.	Typ.	Max.	Unit	Conditions
Turn On Time	$T_{ON}$	—	0.13	5.0	ms	$I_F = 5$ mA, $I_O = 200$ mA
Turn Off Time	$T_{OFF}$	—	0.06	5.0	ms	$I_F = 5$ mA, $I_O = 200$ mA

# Application Information

## On-Resistance and Derating Curves

The Output On-Resistance,  $R_{(ON)}$ , specified in this data sheet is the resistance measured across the output contact when a pulse current signal ( $I_O = 200 \text{ mA}$ ) is applied to the output pins. The use of a pulsed signal ( $\leq 30 \text{ ms}$ ) implies that each junction temperature is equal to the ambient and case temperatures. The steady-state resistance,  $R_{SS}$ , on the other hand, is the value of resistance measured across the output contact when a DC current signal is applied to the output pins for a duration sufficient to reach thermal equilibrium.  $R_{SS}$  includes the effects of the temperature rise in the device.

Figure 1, Figure 2, Figure 3, and Figure 4 specify the maximum average output current allowable for a given ambient temperature. The maximum allowable output current and power dissipation are related by the following expression, from which  $R_{SS}$  is calculated:

$$R_{SS} = P_{O(max)} \div (I_{O(max)})^2$$

Staying within the safe area assures that the steady state MOSFET junction temperature remains less than  $125^\circ\text{C}$ .

**Figure 1: Maximum Output Current Rating vs. Ambient Temperature (ASSR-1218-003E)**

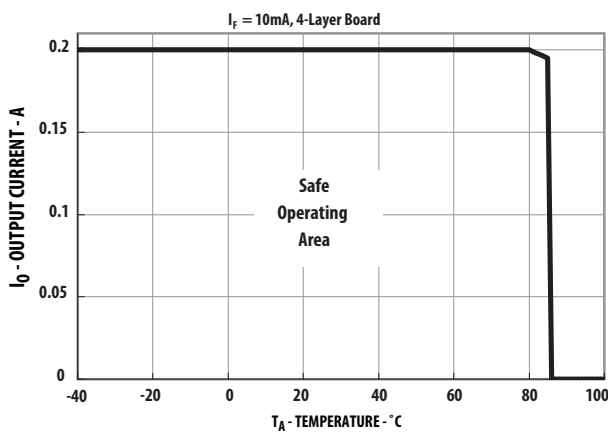

**Figure 2: Maximum Output Current Rating vs. Ambient Temperature (ASSR-1219-001E)**

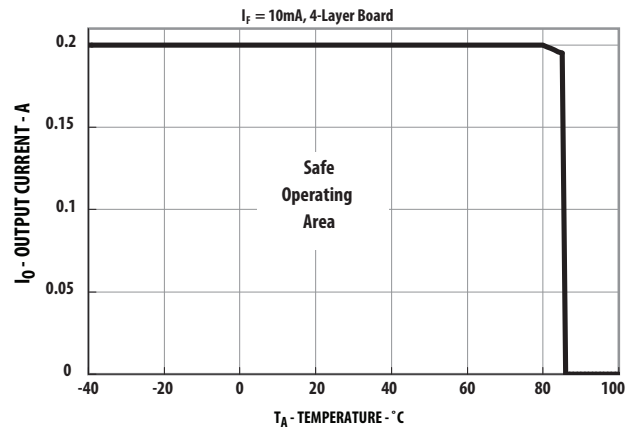

**Figure 3: Maximum Output Current Rating vs. Ambient Temperature (ASSR-1219-001E DC Connection)**

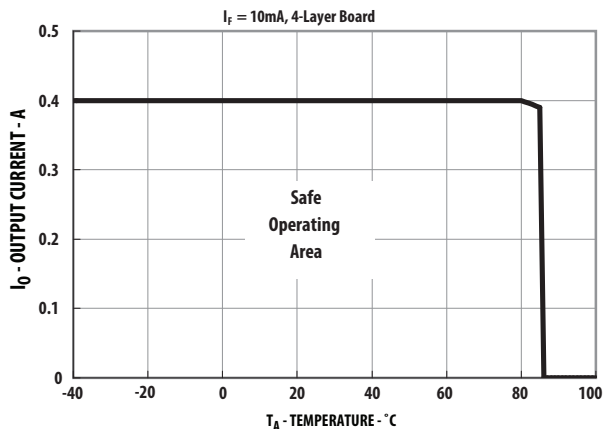

**Figure 4: Maximum Output Current Rating vs. Ambient Temperature (ASSR-1228-002E)**

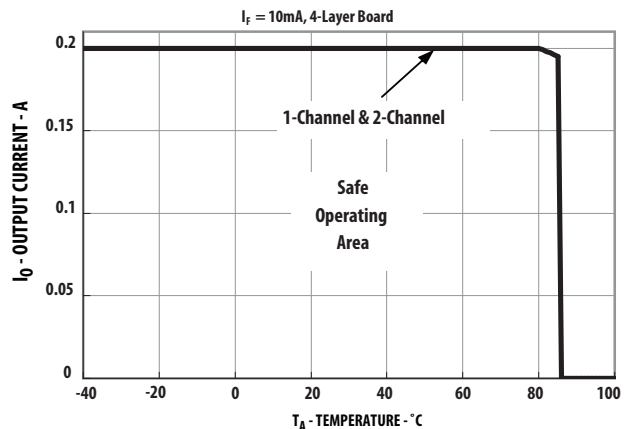

Figure 5: Normalized Output Withstand Voltage vs. Temperature

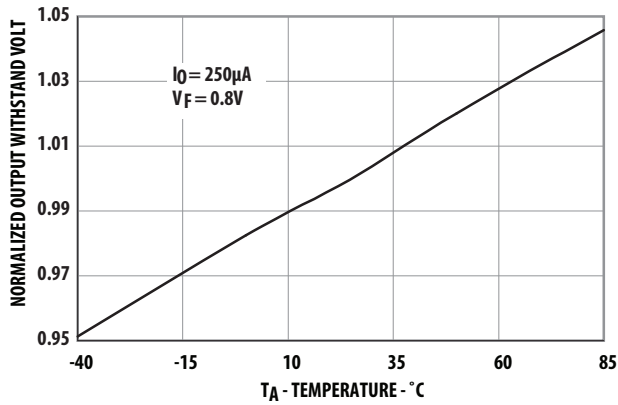

Figure 6: Typical Forward Voltage vs. Temperature

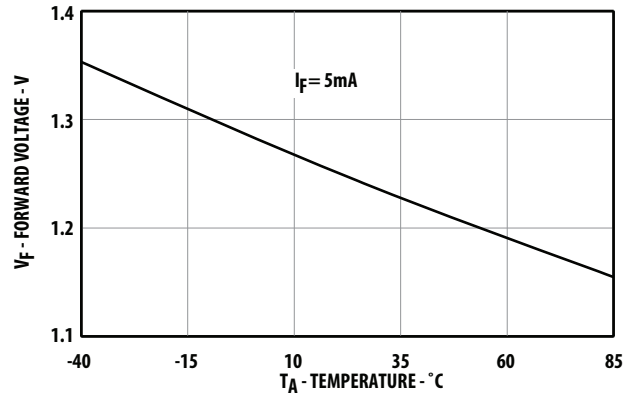

Figure 7: Typical Forward Current vs. Forward Voltage

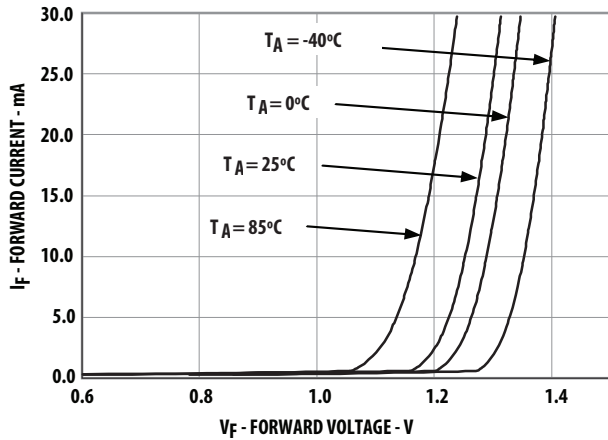

Figure 8: Typical On-Resistance vs. Temperature

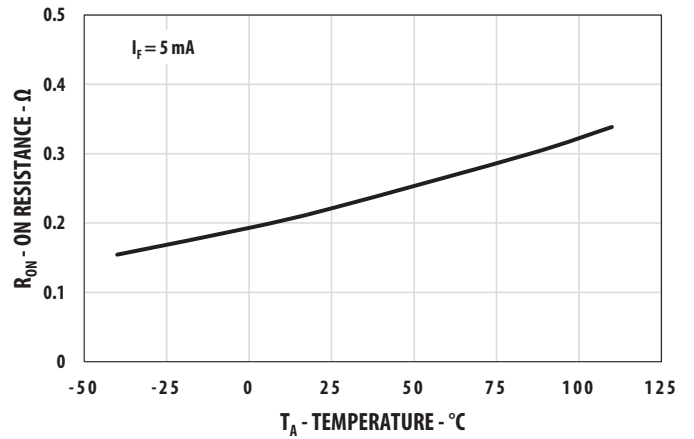
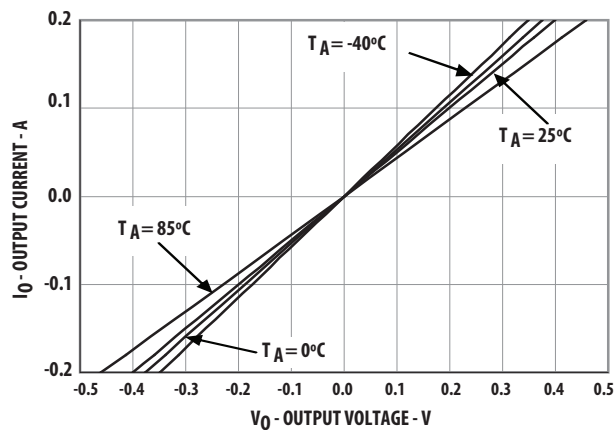

Figure 9: Typical Output Current vs. Output Voltage



Copyright © 2012–2023 Broadcom. All Rights Reserved. The term “Broadcom” refers to Broadcom Inc. and/or its subsidiaries. For more information, go to [www.broadcom.com](http://www.broadcom.com). All trademarks, trade names, service marks, and logos referenced herein belong to their respective companies.

Broadcom reserves the right to make changes without further notice to any products or data herein to improve reliability, function, or design. Information furnished by Broadcom is believed to be accurate and reliable. However, Broadcom does not assume any liability arising out of the application or use of this information, nor the application or use of any product or circuit described herein, neither does it convey any license under its patent rights nor the rights of others.

