

AFCT-5745NPZ/UPZ

Family of Single-Mode SFP Transceivers for Long Reach SONET OC-48 and SDH/STM-16 with Digital Diagnostic Monitoring (DDM) Interface
Part of the Avago METRAK family

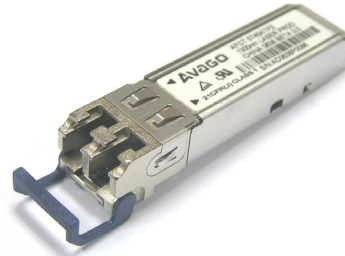

Data Sheet



Description

The AFCT-5745Z are high performance, cost effective modules for serial optical data communications applications that range from 125 Mb/s to 2.7 Gb/s. They are designed to provide SONET/SDH compliant connections for 2488 Mb/s at links up to 40 km and 80 km. All modules are designed for single mode fiber and operate at a nominal wavelength of 1300 nm. The transmitter section of the AFCT-5745NPZ incorporates a 1300 nm Distributed Feedback (DFB) laser. The transmitter in the AFCT-5745UPZ uses a 1550 nm Distributed Feedback (DFB) Laser.

For each device the receiver section uses an Avalanche Photodiode (APD). A positive-ECL logic interface simplifies interface to external circuitry.

The AFCT-5745Z adds digital diagnostic monitoring to standard SFP functionality, enabling fault isolation, components monitoring and failure prediction capabilities.

The diagnostic features allow the host to observe real time temperature, supply voltage, laser bias current, laser average output power and received input average power through the legacy SFP two wire serial memory interface. Conventional memory information found in legacy SFPs is also available in these enhanced transceivers.

Hot-plugging is ensured by design and by 3-stage pin sequencing at the electrical interface.

Part Number Options

The AFCT-5745Z SFP family consists of the following products:

Part Number	Link Distance	Temperature*	Latch Design
AFCT-5745NPZ	40km	Extended	Bail
AFCT-5745ANPZ	40km	Industrial	Bail
AFCT-5745UPZ	80km	Extended	Bail
AFCT-5745AUPZ	80km	Industrial	Bail

* Extended Temperature Range is -10 to 85 °C
Industrial Temperature Range is -40 to 85 °C

Features

- RoHS-6 Compliant
- Compliant with SFF-8472, internally calibrated diagnostic monitoring for optical transceivers
 - Transceiver optical output power
 - Receiver average optical power
 - Laser bias current
 - Device temperature
 - Supply voltage
- Compliant with SFF-8074i SFP transceiver specification
- Compliant with ITU-T G957 STM-16 L-16.1 (40km) and L-16.2 (80km)
- Compliant with Telcordia GR253 LR-1 (40km) and LR-2 (80km)
- Class 1 CDRH/IEC 825 eye safety compliant
- Operating case temperature:
 - 10 °C to +85 °C
 - 40 °C to +85 °C
- Multirate operation from 125 Mb/s to 2.7 Gb/s
- LC duplex fiber connector
- Manufactured in an ISO 9001 compliant facility

Applications

- SONET ADMs (Add/Drop Multiplexers)
- Multi-Service Edge & Aggregation Platforms
- ATM switches and routers
- SONET/SDH switch infrastructure
- xDSL applications
- Metro edge switching

Related Products

- AFCT-5765xZ family of OC3 SFP transceivers with DMI
- AFCT-5755xZ family of OC12 SFP transceivers with DMI

Functional Description

Receiver Section Design

The receiver section for the AFCT-5745Z contains an In-GaAs/InP photo detector and a preamplifier mounted in an optical subassembly. This optical subassembly is coupled to a postamplifier/decision circuit on a circuit board. The postamplifier is ac coupled to the preamplifier. The coupling capacitors are chosen to pass the SONET/SDH test pattern at 155 Mb/s, 622 Mb/s and 2.488 Gb/s without significant distortion or performance penalty.

For multirate applications the sensitivity will meet the maximum SONET specification for OC48 across all data-rates (-28dBm) for 2²³-1 PRBS patterns as well as for dc balanced codes, e.g. 8B/10B. For codes that have a significantly lower frequency content, jitter and pulse distortion could be degraded.

Loss of Signal

The Loss of Signal (LOS) output indicates that the optical input signal to the receiver does not meet the minimum detectable level for compliant signals. When LOS is high it indicates loss of signal. When LOS is low it indicates normal operation. The Loss of Signal thresholds are set to indicate a definite optical fault has occurred (eg., disconnected or broken fiber connection to receiver, failed transmitter).

Transmitter Section Design

A schematic diagram for the transmitter is shown in Figure 1. The AFCT-5745NPZ incorporates a 1310nm DFB laser as its optical source, the AFCT-5745UPZ incorporates a 1550nm DFB laser as its optical source. All part numbers have been designed to be compliant with IEC 825 and CDRH eye safety requirements. The optical output is controlled by a custom IC that detects the laser output via the monitor photodiode. This IC provides both dc and ac current drive to the laser to ensure correct modulation, eye diagram and extinction ratio over temperature, supply voltage and operating life.

TX_FAULT

The AFCT-5745Z modules feature a transmit fault control signal output which when high indicates a laser transmit fault has occurred and when low indicates normal laser operation. A transmitter fault condition can be caused by deviations from the recommended module operating conditions or by violation of eye safety conditions. A fault is cleared by cycling the TX_DISABLE control input.

TX_DISABLE

The AFCT-5745Z accepts a transmit disable control signal input which shuts down the transmitter. A high signal implements this function while a low signal allows normal laser operation. In the event of a fault (eg., eye safety circuit activated), cycling this control signal resets the module. The TX_DISABLE control should be actuated upon initialization of the module.

Digital Diagnostic Interface and Serial Identification (EEPROM)

The AFCT-5745Z complies with both SFF-8074i (SFP) and SFF-8472 (Digital Diagnostic SFP) specifications available from the SFF Committee at <http://www.sffcommittee.org>. The AFCT-5745Z adds digital diagnostic monitoring to standard SFP functionality, enabling failure prediction, fault isolation, and component monitoring capabilities. The transceiver continues to use the 2-wire I²C compatible serial interface. Standard SFP EEPROM bytes 0-255 are addressed per SFF-8074i at memory address 0xA0 (A0h). New digital diagnostic information is accessed per SFF-8472 using EEPROM bytes 0-255 at memory address 0xA2 (A2h).

The AFCT-5745Z provides real time access to transceiver internal supply voltage and temperature, transmitter output power, laser bias current and receiver average input power, allowing a host to predict system compliance issues.

These 5 parameters are reported "internally" calibrated as described in SFF-8472.

Module Description

The transceiver meets the Small Form Pluggable (SFP) industry standard package utilizing an integral LC-Duplex optical interface connector. The hot-pluggable capability of the SFP package allows the module to be installed at any time - even with the host system operating and on-line. This allows for system configuration changes or maintenance without system down time.

Module Diagrams

Figure 1 illustrates the major functional components of the AFCT-5745Z. The connection diagram of the module is shown in Figure 2. Figure 3 depicts the external configuration of the module. Figure 4 depicts the MSA recommended power supply filter.

Installation

The AFCT-5745Z can be installed in or removed from any Multisource Agreement (MSA) –compliant Small Form Pluggable port regardless of whether the host equipment is operating or not. The module is simply inserted, electrical interface first, under finger pressure. Controlled hot-plugging is ensured by design and by 3-stage pin sequencing at the electrical interface. The module housing makes initial contact with the host board EMI shield mitigating potential damage due to Electro-Static Discharge (ESD). The 3-stage pin contact sequencing involves (1) Ground, (2) Power, and then (3) Signal pins, making contact with the host board surface mount connector in that order.

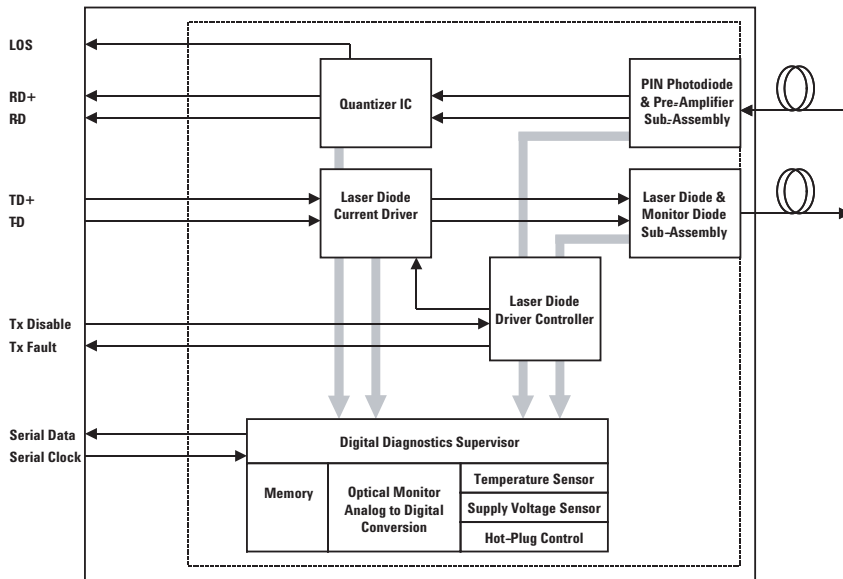

Figure 1. Transceiver Functional Block Diagram

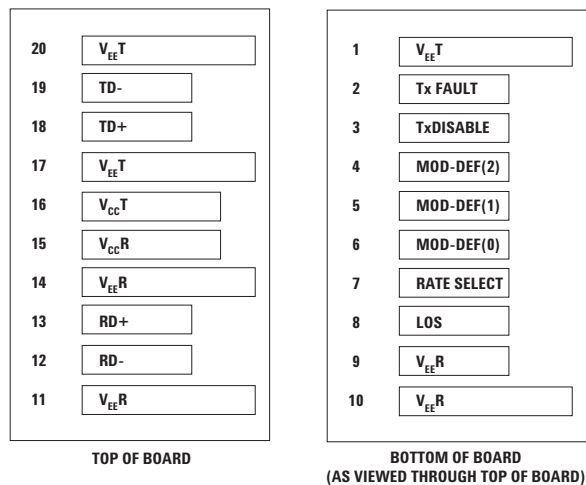

Figure 2. Connection Diagram of Module Printed Circuit Board

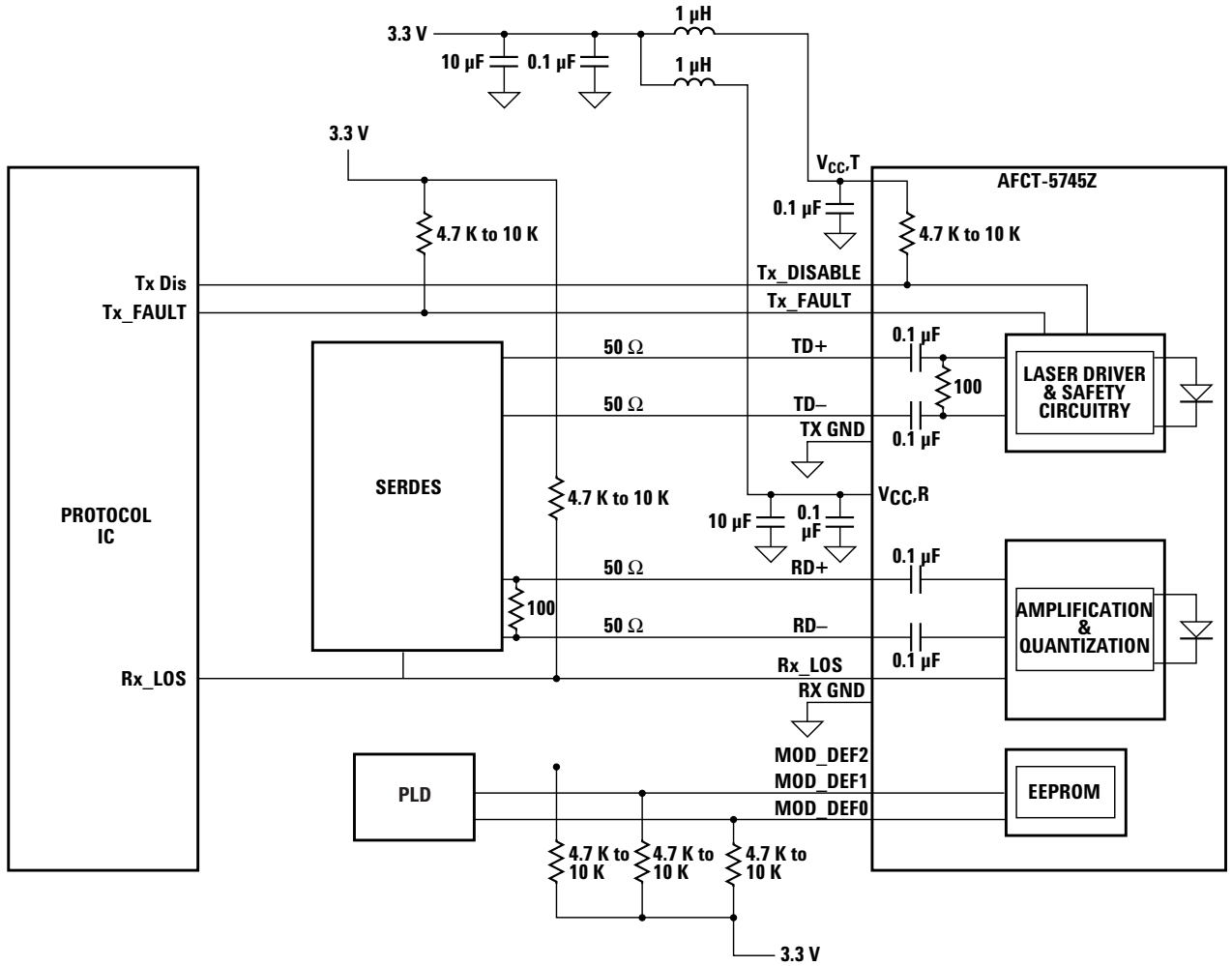
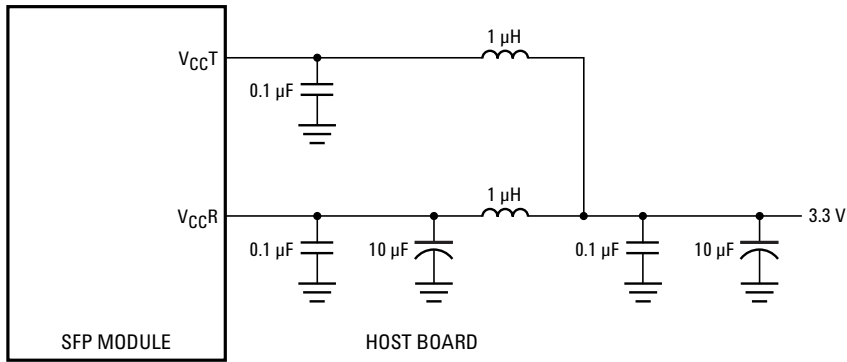

Figure 3. Recommended Application Configuration



NOTE: INDUCTORS MUST HAVE LESS THAN 1 Ω SERIES RESISTANCE PER MSA.

Figure 4. Recommended MSA power supply filter

Table 1. Pin-out Table

The pin arrangement and definition of this product meets SFP MSA. Table 1 lists the pin description.

Pin	Name	Function/Description	Notes
1	VEET	Transmitter Ground	
2	TX_FAULT	Transmitter Fault Indication	Note 1
3	TX_DISABLE	Transmitter Disable - Module disables on high or open	Note 2
4	MOD-DEF 2	Module Definition 2 - Two wire serial ID interface	Note 3
5	MOD-DEF 1	Module Definition 1 - Two wire serial ID interface	Note 3
6	MOD-DEF 0	Module Definition 0 - Grounded in module	Note 3
7	Rate Select	Not Connected	
8	LOS	Loss of Signal	Note 4
9	VEER	Receiver Ground	Note 5
10	VEER	Receiver Ground	Note 5
11	VEER	Receiver Ground	Note 5
12	RD-	Inverse Received Data Out	Note 6
13	RD+	Received Data Out	Note 6
14	VEER	Receiver Ground	Note 5
15	VCCR	Receiver Power - 3.3 V \pm 5%	Note 7
16	VCC T	Transmitter Power - 3.3 V \pm 5%	Note 7
17	VEET	Transmitter Ground	Note 5
18	TD+	Transmitter Data In	Note 8
19	TD-	Inverse Transmitter Data In	Note 8
20	VEET	Transmitter Ground	Note 5

Notes:

- TX_FAULT is an open collector/drain output which should be pulled up externally with a 4.7 – 10 K Ω resistor on the host board to a supply < V_{CC} +0.3 V. When high, this output indicates a laser fault of some kind. Low indicates normal operation. In the low state, the output will be pulled to < 0.8 V.
- TX disable input is used to shut down the laser output per the state table below (internal 10 K Ω pull-up resistor).

Low (0 – 0.8 V):	Transmitter on
Between (0.8 V and 2.0 V):	Undefined
High (2.0 – 3.465 V):	Transmitter Disabled
Open:	Transmitter Disabled
- Mod-Def 0,1,2. These are the module definition pins. They should be pulled up with a 4.7-10 K Ω resistor on the host board to a supply less than V_{CC T} +0.3 V or V_{CC R} +0.3 V.
 Mod-Def 0 is grounded by the module to indicate that the module is present
 Mod-Def 1 is clock line of two wire serial interface for optional serial ID
 Mod-Def 2 is data line of two wire serial interface for optional serial ID
- LOS (Loss of Signal) is an open collector/drain output which should be pulled up externally with a 4.7 – 10 K Ω resistor on the host board to a supply < V_{CC T,R}+0.3 V. When high, this output indicates the received optical power is below the worst case receiver sensitivity (as defined by the standard in use). Low indicates normal operation. In the low state, the output will be pulled to < 0.8 V. Please see later section for LOS timing.
- V_{EE R} and V_{EE T} are internally connected within the SFP module
- RD-/+: These are the differential receiver outputs. They are ac coupled 100 Ω differential lines which should be terminated with 100 Ω differential at the user SERDES. The ac coupling is done inside the module and is thus not required on the host board. The voltage swing on these lines will be between 370 and 2000 mV differential (185 – 1000 mV single ended) when properly terminated.
- V_{CC R} and V_{CC T} are the receiver and transmitter power supplies. They are defined as 3.1 – 3.5 V at the SFP connector pin. The maximum supply current is 300 mA. V_{CC R} and V_{CC T} are internally connected. See the Application Note for further recommendations on power supply filtering.
- TD-/+: These are the differential transmitter inputs. They are ac coupled differential lines with 100 Ω differential termination inside the module. The ac coupling is done inside the module and is thus not required on the host board. The inputs will accept differential swings of 500 – 2400 mV (250 – 1200 mV single ended).

Table 2. EEPROM Serial ID Memory Contents - Address A0h

Address	Hex	Notes/ASCII	Address	Hex	Notes/ASCII	Address	Hex	Notes/ASCII
0	03	SFP physical device	27	20		54	20	
1	04	SFP function defined by serial ID only	28	20		55	20	
2	07	LC optical connector	29	20		56	20	
3	00		30	20		57	20	
4	Table 3	Sonet Reach Specifier	31	20		58	20	
5	00		32	20		59	20	
6	00		33	20		60	Table 3	Hex byte of laser wavelength (Note 2)
7	00		34	20		61	Table 3	Hex byte of laser wavelength (Note 2)
8	00		35	20		62	00	
9	00		36	00		63		Checksum for Bytes 0-62 (Note 3)
10	00		37	00	Hex Byte of Vendor OUI (Note 1)	64	00	
11	05	SONET Scrambled	38	17	Hex Byte of Vendor OUI (Note 1)	65	1A	Hardware SFP Tx_Disable, Tx_Fault & Rx_LOS
12	19	2488 Mbit/sec nominal bit rate	39	6A	Hex Byte of Vendor OUI (Note 1)	66	00	Upper Bit Rate Margin
13	00		40	41	A	67	00	Lower Bit Rate Margin
14	Table 3	Link length 9 μ in km	41	46	F	68-83		Vendor Specific Serial Number ASCII characters (Note 4)
15	Table 3	Link length 9 μ in m	42	43	C	84-91		Vendor Date Code ASCII characters (Note 5)
16	00		43	54	T	92	68	Digital Diagnostics, Internal Cal, Rx PAV
17	00		44	2D	-	93	F0	Soft SFP Tx_Disable, Tx_Fault & Rx_LOS
18	00		45	35	5	94	01	SFF-8472 Compliance to Revision 9.0
19	00		46	37	7	95		Checksum for Bytes 64-94 (Note 3)
20	41	A	47	34	4	96-127	00	Vendor specific EEPROM
21	56	V	48	35	5	128-255	00	Reserved
22	41	A	49	Table 3				
23	47	G	50	20				
24	4F	0	51	20				
25	20		52	20				
26	20		53	20				

Notes:

1. The IEEE Organizationally Unique Identifier (OUI) assigned to Avago is 00-17-6A (3 bytes of hex).
2. Laser wavelength is represented in 16 unsigned bits. The hex representation of 1310 nm and 1550 nm are 051E and 600E respectively.
3. Addresses 63 and 95 are checksums calculated (per SFF-8472 and SFF-8074) and stored prior to product shipment.
4. Addresses 68-83 specify the AFCT-5745Z ASCII serial number and will vary on a per unit basis.
5. Addresses 84-91 specify the AFCT-5745Z ASCII date code and will vary on a per date code basis.
6. Module is compatible with both internal and external DMI Calibration math at host end.

Table 3. Individual Identifiers

AFCT-5745NPZ			AFCT-5745ANPZ			AFCT-5745UPZ			AFCT-5745AUPZ		
Address	Hex	Notes/ASCII	Address	Hex	Notes/ASCII	Address	Hex	Notes/ASCII	Address	Hex	Notes/ASCII
4	14	LR-1	4	14	LR-1	4	0C	LR-2	4	0C	LR-2
14	28	40km	14	28	40km	14	50	80km	14	50	80km
15	FF	40000m	15	FF	40000m	15	FF	80000m	15	FF	80000m
49	4E	N	49	41	A	49	55	U	49	41	A
50	50	P	50	4E	N	50	50	P	50	55	U
51	5A	Z	51	50	P	51	5A	Z	51	50	P
52	20		52	5A	Z	52	20		52	5A	Z
60	05	13	60	05	13	60	06	15	60	60	15
61	1E	10	61	1E	10	61	0E	50	61	0E	5

Table 4. EEPROM Serial ID Memory Contents - Address A2h

Byte # Decimal	Notes	Byte # Decimal	Notes	Byte # Decimal	Notes
0	Temp H Alarm MSB ¹	26	Tx Pwr L Alarm MSB ⁴	104	Real Time Rx PAV MSB ⁵
1	Temp H Alarm LSB ¹	27	Tx Pwr L Alarm LSB ⁴	105	Real Time Rx PAV LSB ⁵
2	Temp L Alarm MSB ¹	28	Tx Pwr H Warning MSB ⁴	106	Reserved
3	Temp L Alarm LSB ¹	29	Tx Pwr H Warning LSB ⁴	107	Reserved
4	Temp H Warning MSB ¹	30	Tx Pwr L Warning MSB ⁴	108	Reserved
5	Temp H Warning LSB ¹	31	Tx Pwr L Warning LSB ⁴	109	Reserved
6	Temp L Warning MSB ¹	32	Rx Pwr H Alarm MSB ⁵	110	Status/Control - see Table 5
7	Temp L Warning LSB ¹	33	Rx Pwr H Alarm LSB ⁵	111	Reserved
8	VCC H Alarm MSB ²	34	Rx Pwr L Alarm MSB ⁵	112	Flag Bits - see Table 6
9	VCC H Alarm LSB ²	35	Rx Pwr L Alarm LSB ⁵	113	Flag Bit - see Table 6
10	VCC L Alarm MSB ²	36	Rx Pwr H Warning MSB ⁵	114	Reserved
11	VCC L Alarm LSB ²	37	Rx Pwr H Warning LSB ⁵	115	Reserved
12	VCC H Warning MSB ²	38	Rx Pwr L Warning MSB ⁵	116	Flag Bits - see Table 6
13	VCC H Warning LSB ²	39	Rx Pwr L Warning LSB ⁵	117	Flag Bits - see Table 6
14	VCC L Warning MSB ²	40-55	Reserved	118	Reserved
15	VCC L Warning LSB ²	56-94	External Calibration Constants ⁶	119	Reserved
16	Tx Bias H Alarm MSB ³	95	Checksum for Bytes 0-947	120-122	Reserved
17	Tx Bias H Alarm LSB ³	96	Real Time Temperature MSB ¹	123	
18	Tx Bias L Alarm MSB ³	97	Real Time Temperature LSB ¹	124	
19	Tx Bias L Alarm LSB ³	98	Real Time Vcc MSB ²	125	
20	Tx Bias H Warning MSB ³	99	Real Time Vcc LSB ²	126	
21	Tx Bias H Warning LSB ³	100	Real Time Tx Bias MSB ³	127	Reserved ⁸
22	Tx Bias L Warning MSB ³	101	Real Time Tx Bias LSB ³	128-247	Customer Writable ⁹
23	Tx Bias L Warning LSB ³	102	Real Time Tx Power MSB ⁴	248-254	Vendor Specific
24	Tx Pwr H Alarm MSB ⁴	103	Real Time Tx Power LSB ⁴	255	
25	Tx Pwr H Alarm LSB ⁴				

Notes:

1. Temperature (Temp) is decoded as a 16 bit signed twos compliment integer in increments of 1/256 °C.
2. Supply voltage (V_{CC}) is decoded as a 16 bit unsigned integer in increments of 100 μV.
3. Laser bias current (Tx Bias) is decoded as a 16 bit unsigned integer in increments of 2 μA.
4. Transmitted average optical power (Tx Pwr) is decoded as a 16 bit unsigned integer in increments of 0.1 μW.
5. Received average optical power (Rx Pwr) is decoded as a 16 bit unsigned integer in increments of 0.1 μW.
6. Bytes 55-94 are not intended for use with AFCT-5745Z, but have been set to default values per SFF-8472.
7. Bytes 95 is a checksum calculated (per SFF-8472) and stored prior to product shipment.
8. Byte 127 accepts a write but performs no action (reserved legacy byte).
9. Bytes 128-247 are write enabled (customer writable).
10. Byte 255 bits 2 and 3 control laser margining (per Table 7) when an enabling password is entered into bytes 123-126.

Table 5. EEPROM Serial ID Memory Contents - Address A2h, Byte 110

Bit #	Status/Control Name	Description
7	Tx Disable State	Digital state of SFP Tx Disable Input Pin (1 = Tx_Disable asserted)
6	Soft Tx Disable	Read/write bit for changing digital state of SFP Tx_Disable function Note 1)
5	Reserved	
4	Rx Rate Select State	Digital state of SFP Rate Select Input Pin (1 = full bandwidth of 2.488 Gbit) (Note 2)
3	Reserved	
2	Tx Fault State	Digital state of the SFP Tx Fault Output Pin (1 = Tx Fault asserted)
1	Rx LOS State	Digital state of the SFP LOS Output Pin (1 = LOS asserted)
0	Data Ready (Bar)	Indicates transceiver is powered and real time sense data is ready (0 = Ready)

Notes:

1. Bit 6 is logic OR'd with the SFP Tx_Disable input pin 3 ... either asserted will disable the SFP transmitter.
2. AFCT-5745Z does not respond to state changes on Rate Select Input Pin. It is internally hardwired to full bandwidth.

Table 6. EEPROM Serial ID Memory Contents - Address A2h, Bytes 112, 113, 116, 117

Byte	Bit #	Flag Bit Name	Description
112	7	Temp High Alarm	Set when transceiver internal temperature exceeds high alarm threshold.
	6	Temp Low Alarm	Set when transceiver internal temperature exceeds alarm threshold.
	5	VCC High Alarm	Set when transceiver internal supply voltage exceeds high alarm threshold.
	4	VCC Low Alarm	Set when transceiver internal supply voltage exceeds low alarm threshold.
	3	Tx Bias High Alarm	Set when transceiver laser bias current exceeds high alarm threshold.
	2	Tx Bias Low Alarm	Set when transceiver laser bias current exceeds low alarm threshold.
	1	Tx Power High Alarm	Set when transmitted average optical power exceeds high alarm threshold.
	0	Tx Power Low Alarm	Set when transmitted average optical power exceeds low alarm threshold.
113	7	Rx Power High Alarm	Set when received P_Avg optical power exceeds high alarm threshold.
	6	Rx Power Low Alarm	Set when received P_Avg optical power exceeds low alarm threshold.
	0-5	Reserved	
116	7	Temp High Warning	Set when transceiver internal temperature exceeds high warning threshold.
	6	Temp Low Warning	Set when transceiver internal temperature exceeds low warning threshold.
	5	VCC High Warning	Set when transceiver internal supply voltage exceeds high warning threshold.
	4	VCC Low Warning	Set when transceiver internal supply voltage exceeds low warning threshold.
	3	Tx Bias High Warning	Set when transceiver laser bias current exceeds high warning threshold.
	2	Tx Bias Low Warning	Set when transceiver laser bias current exceeds low warning threshold.
	1	Tx Power High Warning	Set when transmitted average optical power exceeds high warning threshold.
	0	Tx Power Low Warning	Set when transmitted average optical power exceeds low warning threshold.
117	7	Rx Power High Warning	Set when received P_Avg optical power exceeds high warning threshold.
	9	Rx Power Low Warning	Set when received P_Avg optical power exceeds low warning threshold.
	0-5	Reserved	

Electrical Parameters

Absolute Maximum Ratings

Absolute maximum ratings are those values beyond which functional performance is not intended, device reliability is not implied, and damage to the device may occur.

Parameter	Symbol	Minimum	Maximum	Unit	Notes
Storage Temperature (non-operating)	T _S	-40	+85	°C	
Relative Humidity	RH	0	85	%	
Supply Voltage	V _{CC}	-0.5	3.63	V	
Input Voltage on any Pin	V _I	-0.5	V _{CC}	V	
Receiver Optical Input	P _{IN} ABS		6	dBm	

Recommended Operating Conditions

Typical operating conditions are those values for which functional performance and device reliability is implied.

Parameter	Symbol	Minimum	Typical	Maximum	Unit	Notes
Case Operating Temperature						
AFCT-5745NPZ/UPZ	T _C	-10		+85	°C	11
AFCT-5745ANPZ/AUPZ	T _C	-40		+85	°C	
Supply Voltage	V _{CC}	3.1	3.3	3.5	V	

Transceiver Electrical Characteristics

Parameter	Symbol	Minimum	Typical	Maximum	Unit	Notes
Module supply current	I _{CC} T			300	mA	2
Power Dissipation	P _{DISS}			1000	mW	
AC Electrical Characteristics						
Power Supply Noise Rejection	PSNR	100			mV	3
In-rush Current				30	mA	
DC Electrical Characteristics						
Signal Outputs:						
Transmit Fault (TX_FAULT) Loss of Signal (LOS)	V _{OH}	2.0		3.5	V	4
	V _{OL}	0		0.8	V	
Signal Inputs:						
Transmitter Disable (TX_DISABLE) MOD-DEF1, 2	V _{IH}	2.0		3.5	V	7
	V _{IL}	0		0.8	V	
Data Input:						
Transmitter Single Ended Input Voltage (TD±)	V _I	250		1200	mV	5
Data Output:						
Receiver Single Ended Output Voltage (RD±)	V _O	185		1000	mV	6

Notes:

1. Operating conditions: +70°C ambient, air flow 0.5m/s
2. MSA gives max current at 300 mA.
3. MSA filter is required on host board 10 Hz to 2 MHz.
4. LVTTTL, External 4.7-10 kΩ pull up resistor required on host board to voltage less than V_{CC}+0.3 V.
5. Internally ac coupled and terminated (100 Ω differential).
6. Internally ac coupled and load termination located at the user SERDES.
7. Minimum input to MOD-DEF1,2 is 0.7*V_{CC}

Transmitter Optical Characteristics

Parameter		Symbol	Min.	Typ.	Max.	Unit	Reference
Output Optical Power 9 μ m SMF		P _{OUT}	-2		+3	dBm	1
Center Wavelength	AFCT-5745NPZ/ANPZ	λ_C	1270		1360	nm	
	AFCT-5745UPZ/AUPZ		1500		1580	nm	
-20dB Spectral Width		$\Delta\lambda_{20}$			1	nm	7
SMSR			30			dB	
Optical Rise Time		t _r			150	ps	3
Optical Fall Time		t _f			200	ps	3
Extinction Ratio		E _R	8.2			dB	
Back Reflection Sensitivity					-8.5	dB	4
Jitter Generation		pk to pk			70	mUI	5
		RMS			7	mUI	5
Path Penalty					2	dB	

Receiver Optical Characteristics

Parameter		Symbol	Min.	Typ.	Max.	Unit	Reference
Receiver Sensitivity		P _{IN} MIN			-28	dBm avg.	6
Receiver Overload		P _{IN} MAX	-9			dBm avg.	6
Input Operating Wavelength		λ	1260		1580	nm	
LOS - Deasserted		P _{LOSD}			-28.5	dBm avg.	
LOS - Asserted		P _{LOSA}	-45			dBm avg.	
LOS - Hysteresis		P _H	0.5		4	dB	
Reflectance					-27	dB	

Notes:

1. The output power is coupled into a 1 m single mode fiber. Minimum output optical level is at end of life.
2. The relationship between FWHM and RMS values for spectral width can be derived from the assumption of a Gaussian shaped spectrum which results in RMS = FWHM/2.35.
3. These are unfiltered 20 - 80% values.
4. This meets the "desired" requirement in SONET specification (GR253). The figure given is the allowable mismatch for 1 dB degradation in receiver sensitivity.
5. For the jitter measurements, the device was driven with SONET OC-48C data pattern filled with a 2²³-1 PRBS payload.
6. P_{IN} represents the typical optical input sensitivity of the receiver. Minimum sensitivity (P_{IN}MIN) and saturation (P_{IN}MAX) levels for a 2²³-1 PRBS test pattern. Over the range the receiver is guaranteed to provide output data with a Bit Error Rate better than or equal to 1 x 10⁻¹⁰. For multirate applications the sensitivity will meet the maximum SONET specification for OC-48 across all datarates (-19 dBm).
7. Spectral width of main laser peak measured 20 dB below peak spectral density.

Transceiver Digital Diagnostic Monitor (Real Time Sense) Characteristics

($T_C = -10\text{ }^\circ\text{C}$ to $+85\text{ }^\circ\text{C}$, $V_{CC1, R} = 3.1\text{ V}$ to 3.5 V)

Parameter	Symbol	Min.	Typ.	Max.	Unit	Reference
Transceiver Internal Temperature Accuracy	T_{INT}	-3.0		+3.0	$^\circ\text{C}$	1
Transceiver Internal Supply Voltage Accuracy	V_{INT}	-3.0		+3.0	%	2
Transmitter Laser dc Bias Current Accuracy	I_{INT}	-10		+10	%	3
Transmitted Average Optical Output Power Accuracy	P_T	-3.0		+3.0	dB	
Received Average Optical Input Power Accuracy	P_R	-3.0		+3.0	dB	

Notes:

1. Temperature was measured internal to the transceiver. Valid from $-10\text{ }^\circ\text{C}$ to $+85\text{ }^\circ\text{C}$. For calibration to an external temperature, please contact Avago.
2. Reference voltage is 3.3 V.
3. Valid from 0 to 50 mA, avg.

Transceiver Timing Characteristics

Parameter	Symbol	Minimum	Typical	Maximum	Unit	Notes
Tx Disable Assert Time	t_{off}			10	μs	1
Tx Disable Negate Time	t_{on}			1	ms	2
Time to initialize, including reset of Tx-Fault	t_{init}			300	ms	3
Tx Fault Assert Time	t_{fault}			100	μs	4
Tx Disable to Reset	t_{reset}	10			μs	5
LOS Assert Time	t_{loss_on}	2.3		100	μs	6
LOS Deassert Time	t_{loss_off}			100	μs	7
Serial ID Clock Rate	f_{serial_clock}			100	kHz	

Notes:

1. Time from rising edge of Tx Disable to when the optical output falls below 10% of nominal.
2. Time from falling edge of Tx Disable to when the modulated optical output rises above 90% of nominal.
3. From power on or negation of Tx Fault using Tx Disable.
4. Time from fault to Tx fault on.
5. Time Tx Disable must be held high to reset Tx_fault .
6. Time from LOS state to Rx LOS assert.
7. Time from non-LOS state to RX LOS deassert. With RX input power less than -6 dBm and greater than -21 dBm .

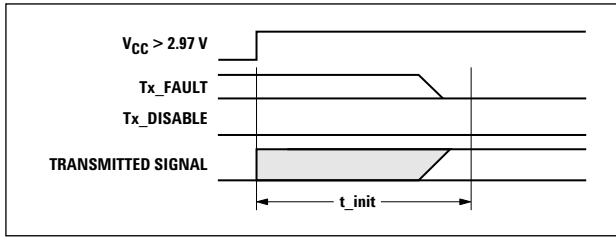

t-init: TX DISABLE NEGATED

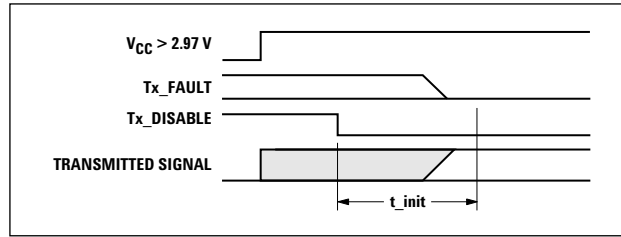

t-init: TX DISABLE ASSERTED

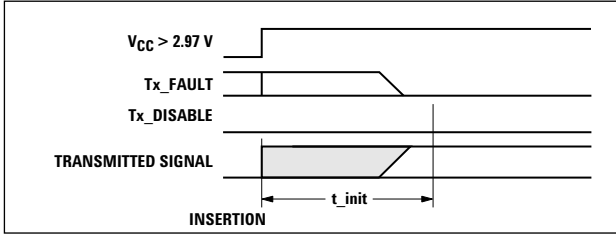

t-init: TX DISABLE NEGATED, MODULE HOT PLUGGED

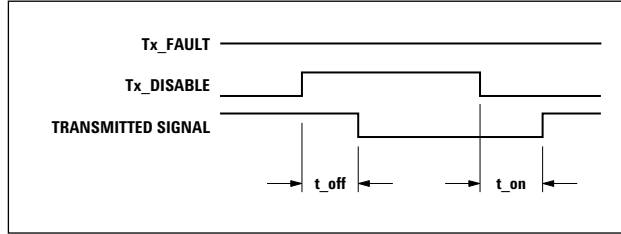

t-off & t-on: TX DISABLE ASSERTED THEN NEGATED

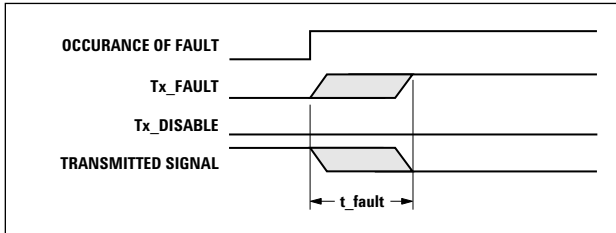

t-fault: TX FAULT ASSERTED, TX SIGNAL NOT RECOVERED

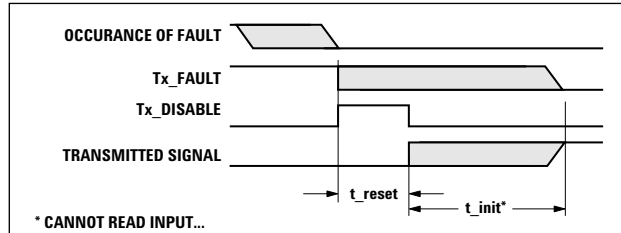

t-reset: TX DISABLE ASSERTED THEN NEGATED, TX SIGNAL RECOVERED

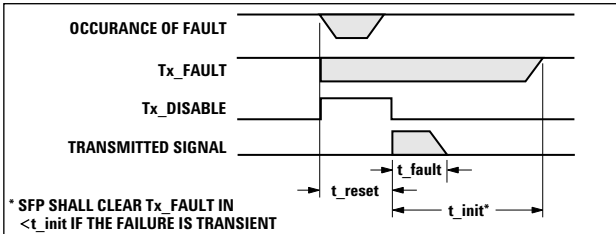

t-fault: TX DISABLE ASSERTED THEN NEGATED, TX SIGNAL NOT RECOVERED

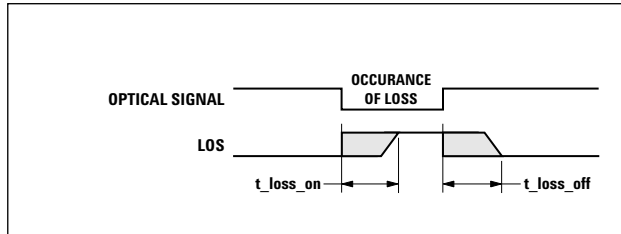

t-loss-on & t-loss-off

Figure 5. Transceiver Timing Diagrams (Module installed except where noted).

Regulatory Compliance

Electrostatic Discharge

There are two conditions in which immunity to ESD damage is important. The first condition is during handling of the transceiver prior to insertion into the transceiver port. To protect the transceiver, it is important to use normal ESD handling precautions. The ESD sensitivity of the AFCT-5745Z is compatible with typical industry production environments. The second condition is static discharges to the exterior of the host equipment chassis after installation. To the extent that the duplex LC optical interface is exposed to the outside of the host equipment chassis, it may be subject to system-level ESD requirements. The ESD performance of the AFCT-5745Z exceeds typical industry standards.

Immunity

Equipment hosting the AFCT-5745Z modules will be subjected to radio-frequency electro-magnetic fields in some environments. These transceivers have good immunity to such fields due to their shielded design.

Eye Safety

These 1300 nm FP and DFB based transceivers provide Class 1 eye safety by design. Avago has tested the transceiver design for compliance with the requirements listed in Table 2 under normal operating conditions and under a single fault condition.

Flammability

The AFCT-5745Z transceiver housing is made of metal and meets UL E173874 standard for flame retardancy.

Electromagnetic Interference (EMI)

Most equipment designs utilizing these high-speed transceivers from Avago will be required to meet the requirements of FCC in the United States, CENELEC EN55022 (CISPR 22) in Europe and VCCI in Japan.

The metal housing and shielded design of the AFCT-5745Z minimize the EMI challenge facing the host equipment designer. These transceivers provide superior EMI performance. This greatly assists the designer in the management of the overall system EMI performance.

Regulatory Compliance

Feature	Test Method	Performance
Electrostatic Discharge (ESD) to the Electrical Pins	MIL-STD-883C Method 3015.4	Class 1 (2000 Volts)
Electrostatic Discharge (ESD) to the Duplex LC Receptacle	Variation of IEC 61000-4-2 - Direct ESD (ie. front panel connector receptacle).	15 kV (air discharge) and 8 kV (contact). Transceiver shall perform properly during test.
	Variation of IEC 61000-4-2 - Indirect ESD (contact discharge to coupling plane)	15 kV (contact discharge applied to coupling plane). Transceiver shall perform properly during test with no data loss.
Electromagnetic Interference (EMI)	FCC Class B CENELEC EN55022 Class B (CISPR 22A) VCCI Class 1	
Immunity	Variation of IEC 61000-4-3	Typically show no measurable effect from a 10 V/m field swept from 80 to 1000 MHz applied to the transceiver without a chassis enclosure.
Eye Safety	US FDA CDRH AEL Class 1	CDRH certification # 9521220-139
	EN (IEC) 60825-1, 2, EN60950 Class 1	TUV file # 933/21205741/11
Component Recognition	Underwriter's Laboratories and Canadian Standards Association Joint Component Recognition for Information Technology Equipment Including Electrical Business Equipment	UL file # E173874
RoHS Compliance		Reference to EU RoHS Directive 2002/95/EC

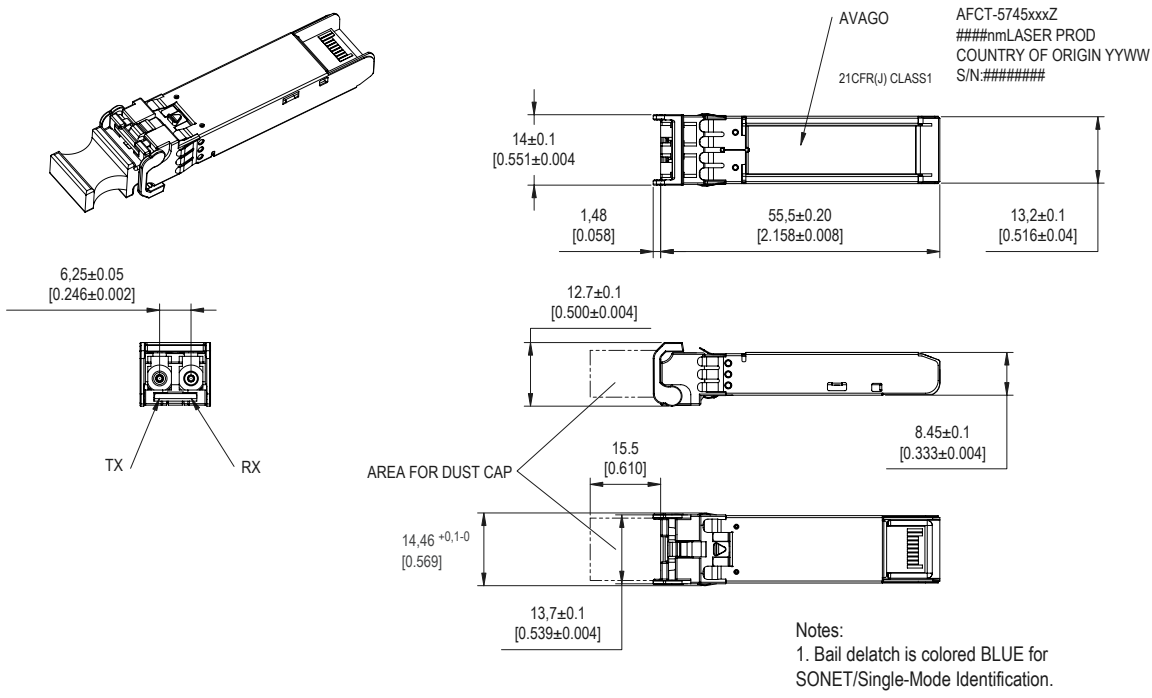

Note 1. Bail delatch is colored BLUE for SONET/Single-Mode Identification.

Figure 6. Module Drawing

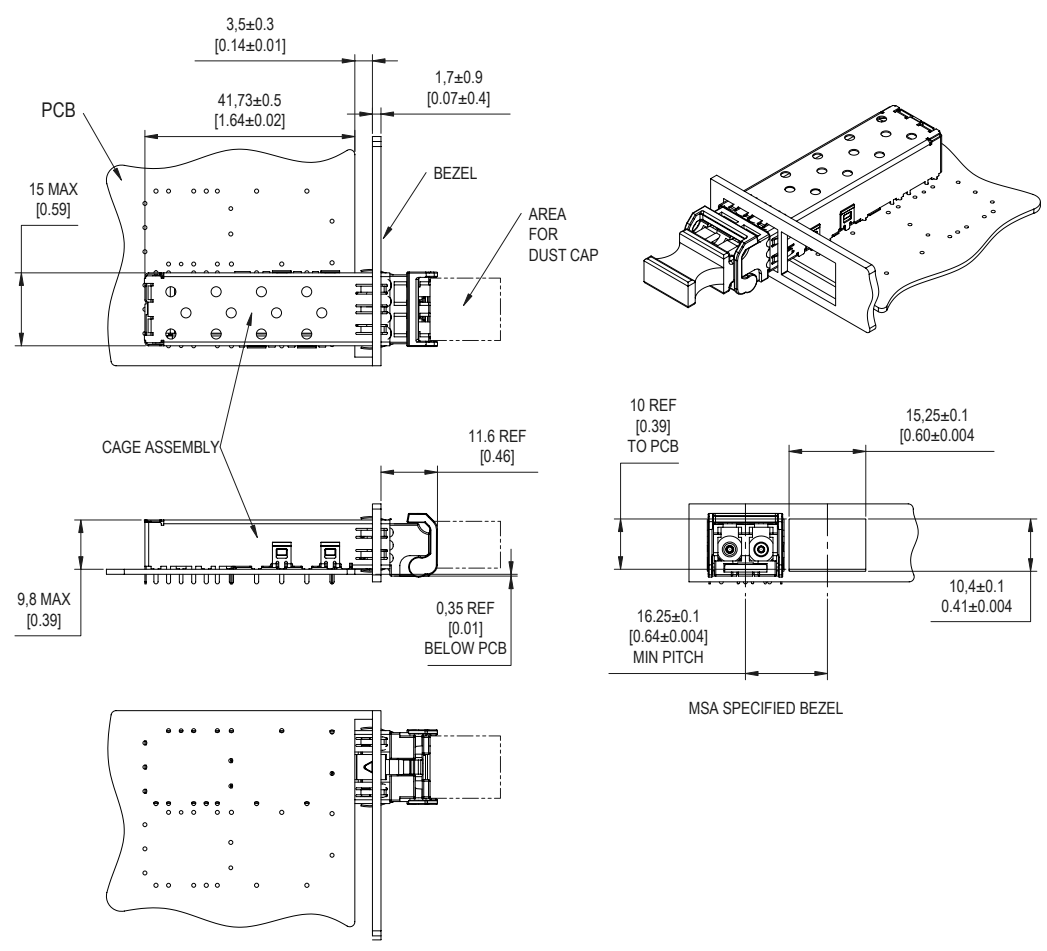

DIMENSION ARE IN MILLIMETERS [INCHES]

Figure 7. Assembly Drawing

Application Information

The Applications Engineering Group at Avago is available to assist you with technical understanding and design trade-offs associated with these transceivers. You can contact them through your Avago sales representative.

The following information is provided to answer some of the most common questions about the use of parts.

Optical Power Budget

The worst-case Optical Power Budget (OPB) in dB for a fiber-optic link is determined by the difference between the minimum transmitter output optical power (dBm avg) and the lowest receiversensitivity (dBm avg). This OPB provides the necessary optical signal range to establish a working fiber-optic link. The OPB is allocated for the fiber-optic cable length and the corresponding link penalties. For proper link performance, all penalties that affect the link performance must be accounted for within the link optical power budget.

Process Plug

This transceiver is supplied with a process plug for protection of the optical port within the LC connector receptacle. This process plug prevents contamination during standard process handling, shipping and storage.

LC SFP Cleaning Recommendations

In the event of contamination of the optical ports, the recommended cleaning process is the use of forced nitrogen. If contamination is thought to have remained, the optical ports can be cleaned using a NTT international Cletop stick type (diam. 1.25 mm) and HFE7100 cleaning fluid.

Customer Manufacturing Processes

This module is pluggable and is not designed for aqueous wash, IR reflow or wave soldering processes.

Caution

There are no user serviceable parts nor any maintenance required for the AFCT-5745Z. Tampering with or modifying the performance of the AFCT-5745Z will result in voided product warranty. It may also result in improper operation of the AFCT-5745Z circuitry, and possible overstress of the laser source. Device degradation or product failure may result. Connection of the AFCT-5745Z to a non-approved optical source, operating above the recommended absolute maximum conditions or operating the AFCT-5745Z in a manner inconsistent with its design and function may result in hazardous radiation exposure and may be considered an act of modifying or manufacturing a laser product. The person(s) performing such an act are required by law to re-certify and re-identify the laser product under the provisions of U.S. 21 CFR (Subchapter J) and the TUV.

Ordering Information

1310nm FP Laser

Operating case temperature: -10 °C to +85 °C

AFCT-5745NPZ LR-1, Plastic Bail Delatch

Operating case temperature: -40 °C to +85 °C

AFCT-5745ANPZ LR-1, Plastic Bail Delatch

1310nm DFB Laser

Operating case temperature: -10 °C to +85 °C

AFCT-5745UPZ LR-2, Plastic Bail Delatch

Operating case temperature: -40 °C to +85 °C

AFCT-5745AUPZ LR-2, Plastic Bail Delatch

EEPROM Content and / or Label Options

AFCT-5745NPZ-YYY LR-1, Plastic Bail Delatch, -10°C to +85°C

AFCT-5745ANPZ-YYY LR-1, Plastic Bail Delatch, -40°C to +85°C

AFCT-5745UPZ-YYY LR-2, Plastic Bail Delatch, -10°C to +85°C

AFCT-5745AUPZ-YYY LR-2, Plastic Bail Delatch, -40°C to +85°C

Where "YYY" is Customer specific

Class 1 Laser Product: This product conforms to the applicable requirements of 21 CFR 1040 at the date of manufacture
Date of Manufacture:
Avago Technologies Inc., No 1 Yishun Ave 7, Singapore

Handling Precautions

1. The AFCT-5745xPZ can be damaged by current surges or overvoltage. Power supply transient precautions should be taken.
2. Normal handling precautions for electrostatic sensitive devices should be taken.

For product information and a complete list of distributors, please go to our web site: www.avagotech.com

Avago, Avago Technologies, and the A logo are trademarks of Avago Technologies, Limited in the United States and other countries. Data subject to change. Copyright © 2007 Avago Technologies Limited. All rights reserved.
AV02-0071EN - June 25, 2007

AVAGO
TECHNOLOGIES