

Isolation Products in Motor Control Systems

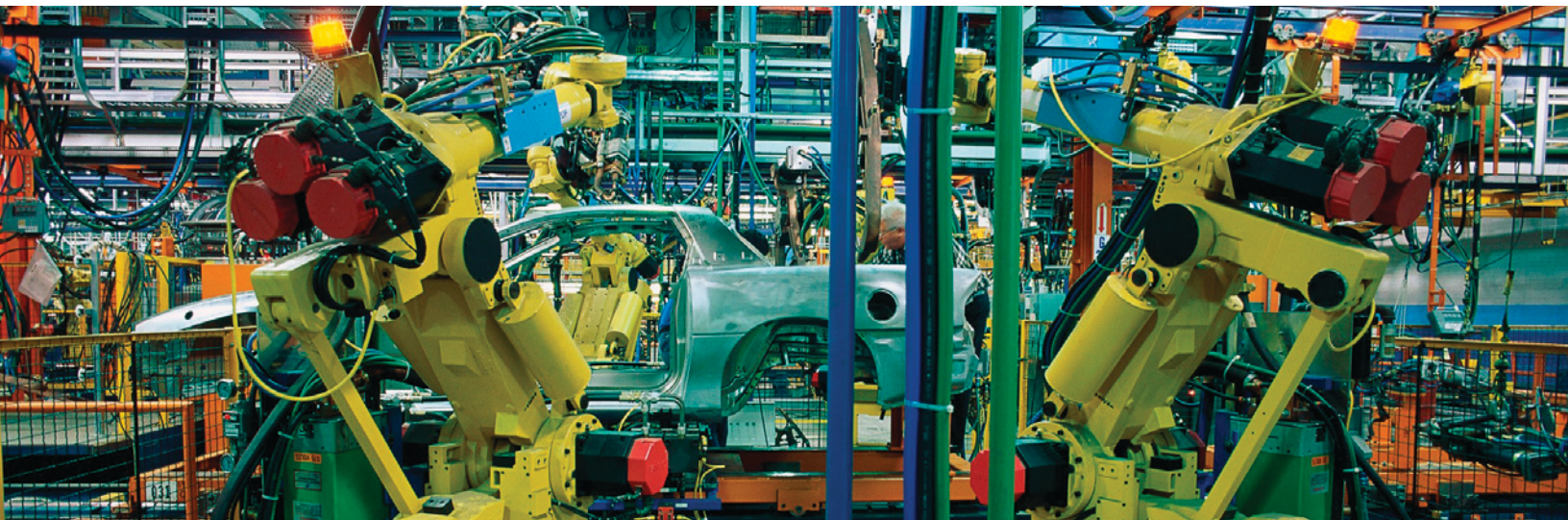

Reference Guide

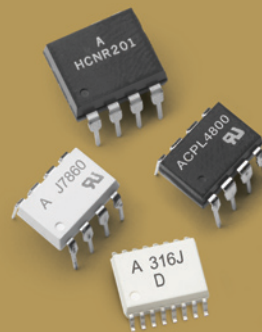

Introduction

Today's highly competitive market demands motor control solutions that offer higher performance, greater functionality and efficiency, and reduced cost. In a motor drive system where high voltages, magnetic fields and noise are commonly present, reliability is critical to avoiding downtime. Optocouplers are used to insulate high voltages and isolate unwanted signals. A wide range of isolation products from Avago Technologies are now available to suit a range of motor control applications.

Avago Technologies offers the most comprehensive line of Intelligent Power Module (IPM) Interface Optocoupler, Integrated Gate Drive Optocoupler and Miniature Isolation Amplifier solutions. Its leading Digital Optocoupler products are highly robust and reliable - even in the harshest environments - and feature leading isolation technology and Common-Mode-Rejection-Ratio (CMR) performance. Avago Technologies' high-linearity analog parts are suitable for systems demanding high accuracy, while its voltage-detection parts detect and isolate interfaces. Avago optocouplers fully comply with regulatory standards worldwide, including IEC (International Electrotechnical Commission), UL (Underwriters Laboratories, Inc.), CSA (Canadian Standard Association) and EN (European Union) approvals. For your motor control system isolation needs, you can't go wrong by choosing Avago Technologies.

Main Components of Motor Control System

In a motor control system there are typically 5 key components: a controller with I/O interface block, gate drivers, sensors, an inverter (power stage), and a motor (Figure 1). The controller (usually an MCU, DSP or embedded processor) processes the requirements of the application, such as torque, speed, direction, and position, and converts this information into a Pulse-Width-Modulation (PWM) signal that is fed to the gate driver. The gate driver turns on the power inverter transistors (IGBT/Power MOSFET/IPM) at very high switching frequency; thereby allowing current to flow. This current then drives the motor at variable speeds, depending on the user-specified target speed. For a stable system, a closed-loop feedback on current, shaft position, temperature, speed, rotation direction, and back EMF is required.



Figure 1 - Motor Control System Block Diagram

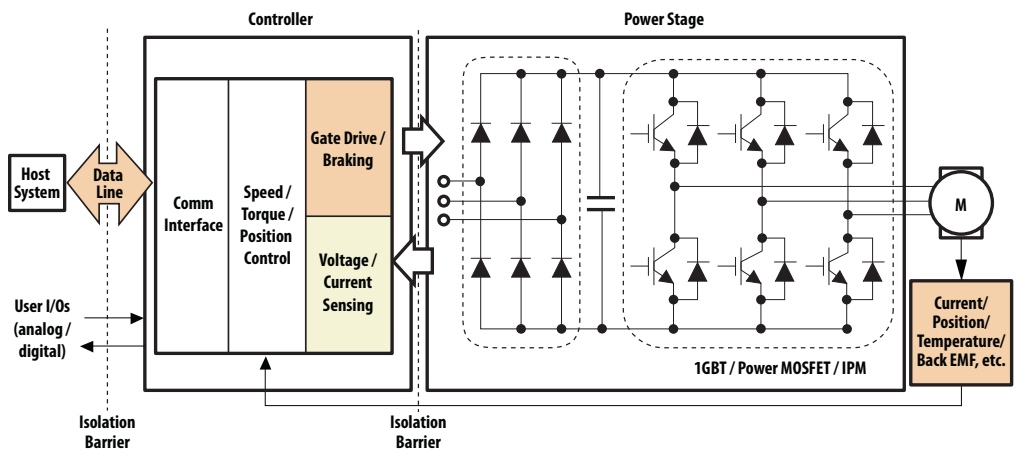
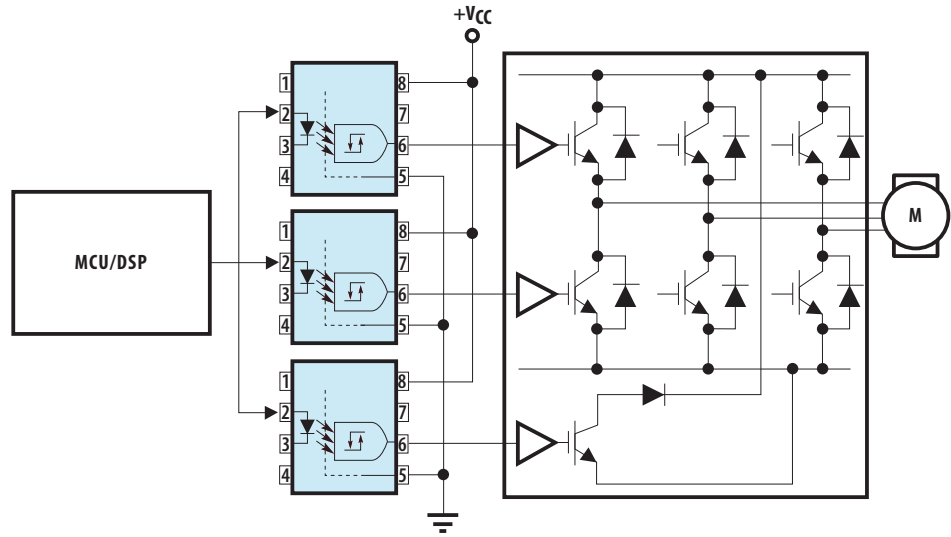

Figure 3 – ACPL-4800 Application Diagram



IPM and Gate Drive Interface Optocouplers

In addition to discrete power switch elements, Intelligent Power Modules have become popular in advanced motor control design, such as in the inverter. An IPM consists of high-performance IGBT power devices with integrated gate drive and protection circuits in one package. The advantages of the IPM include reduced design time, smaller size and improved reliability and manufacturability. Avago’s IPM and gate drive interface optocouplers provide isolation between MCU/PWM controllers and IPMs. Examples include the HCPL-4506 (transistor output) and ACPL-4800 (logic gate output) devices (Figure 3). Each is designed with low drive current, high CMR capabilities and insulation voltage, and operate over a wide temperature range (-40 to 100°C). Both devices also feature a wide supply voltage (4.5 to 30 V), which meets current IPM industrial requirements.

Feedback and Protection

Bus and Phase Current Feedback

Isolating the precision analog signal from the motor current-sensing element is an ongoing challenge facing circuit designers. Avago’s HCPL-7800 high CMR isolation amplifier offers a cost effective replacement for traditional motor sensing devices (e.g. Hall-Effect devices). Even in an extremely high electrical noise environment, it provides both the precision and stability needed to accurately monitor motor current for tighter control in motor control applications. The HCPL-7800 isolation amplifier requires a simple interface circuit which includes a current sensing resistor (Figure 4). Compared to Hall-Effect sensors, HCPL-7800 has excellent gain and offset characteristics, including very low drift over temperature. It also features a very high CMR specification of 15,000 V/μs at 1000-Vpeak voltage, is not affected by external magnetic fields and does not exhibit residual magnetization effects which may affect offset. These versatile features enable the designer to use the same circuit and layout for sensing different motor current ranges; all that’s required is a simple substitution of different current-shunts. Such functionality makes HCPL-7800 an excellent choice for sensing current in a wide range of motor control applications up to 200 A or more.

Figure 4. Optically Isolated Current Sensing Circuit with HCPL-7800 Isolation Amplifier

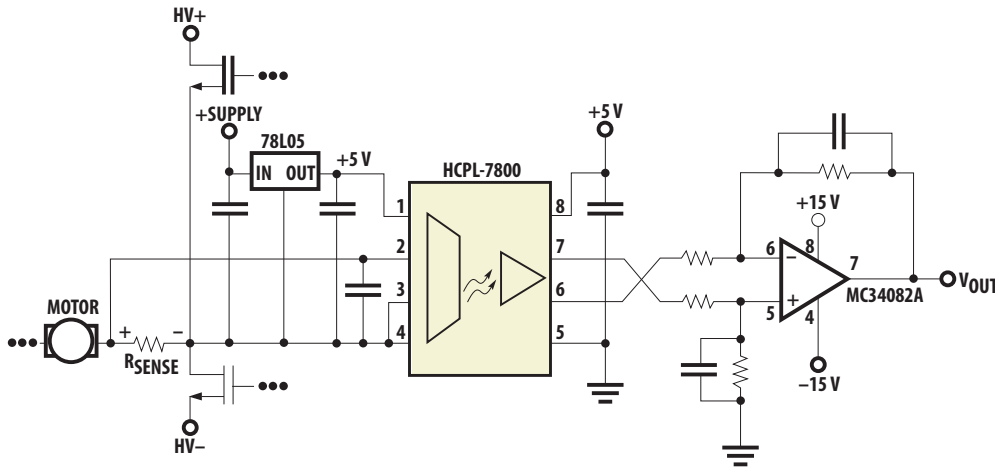

Avago's HCPL-788J, HCPL-7510 and HCPL-7520 isolation amplifiers are recommended for circuit designers who want to have a single-ended output to interface directly with the A/D port of the microcontroller. For those designers who prefer a digital output or an isolated A/D converter, HCPL-7860/786J and HCPL-7560 together with HCPL-0872 offer the ideal solution.

DC and AC Voltage Feedback

Avago's HCPL-7800 and HCPL-7510 isolation amplifiers can also be used for sensing the rectified DC power supply voltage in a power inverter. Since these devices have a maximum specification of 300-mV input voltage before clipping, the DC power supply voltage should be converted to a proportionally smaller voltage. Figure 5 shows a simple resistor divider stage (R1 and R2) before the input of the HCPL-7800. Here the output of HCPL-7800 is proportional to the high-voltage dc power supply.

Figure 5 - Optically Isolated Voltage Sensing Circuit with HCPL-7800 Isolation Amplifier

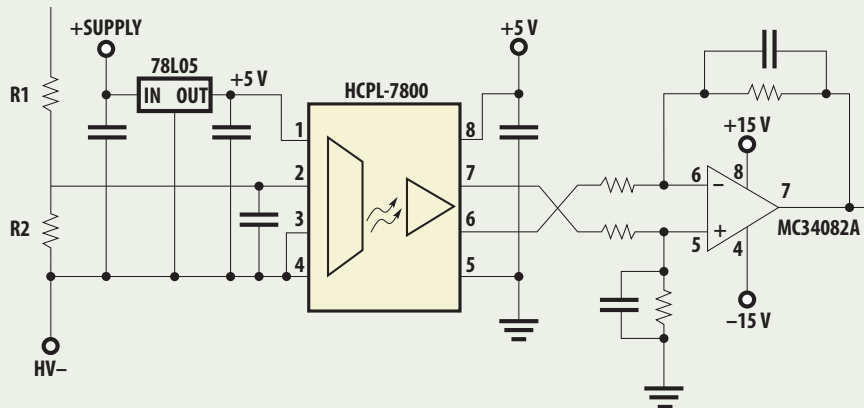

Figure 6 - HCPL-0370/3700/3760 AC Input Configuration

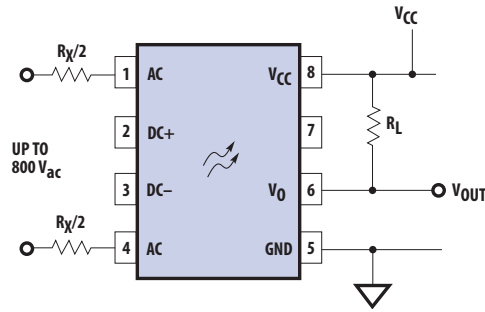
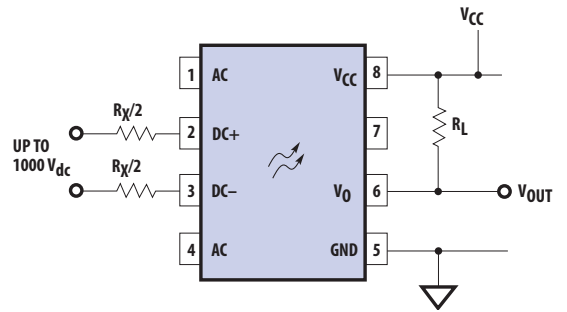

Figure 7 - HCPL-0370/3700/3760 DC Input Configuration



Avago’s HCPL-0370/3700/3760 Threshold-Sensing Optocoupler can be used for sensing the AC/DC power on/off condition (Figures 6 and 7). To limit the current, a pair of series resistors ($R_X/2$) is required at the optocoupler input. The AC signal can be filtered with a capacitor at either the input or the output of the optocoupler. The value of R_X determines the threshold sensing voltage.

Analog Isolation for Temperature, Back EMF, Back EMF Zero Crossing, Speed, and Positioning Feedback

The high linearity analog optocoupler, HCNR201, can be used as a high-speed, low-cost isolation amplifier in the feedback of temperature, back EMF, back EMF zero crossing, speed, positioning and others. It is ideal for use in applications where high bandwidth, low cost, and stable gain are required, but where accuracy is not critical. A common schematic of the analog optoisolation block is shown in Figure 8.

Connectivity

Besides user I/Os for local control, a motor control communication interface provides connectivity between the motor control unit and host system in an industrial control and automation environment. Fieldbus and networking technologies, based on dedicated twisted pair cables or RS-485 cabling, are commonly used in the motor control digital communication interface.

The interface devices used in a motor control system, especially those used in industrial applications to transmit data throughout the network or portion of the system through the bus line, need to be robust and reliable to perform in typically harsh environments. High CMR performance and isolation voltage are a few of the features highly desirable in these applications. Avago’s optocouplers provide the necessary electrical isolation required in this environment. Avago’s offering includes miniature surface-mount optocoupler packages for high-density applications, as well as multi-channel, bi-directional optocouplers.

Figure 8 - Simplified Analog Isolation Block

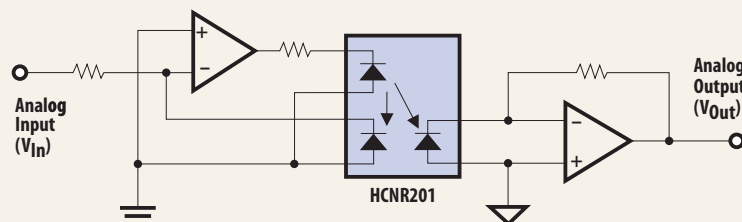
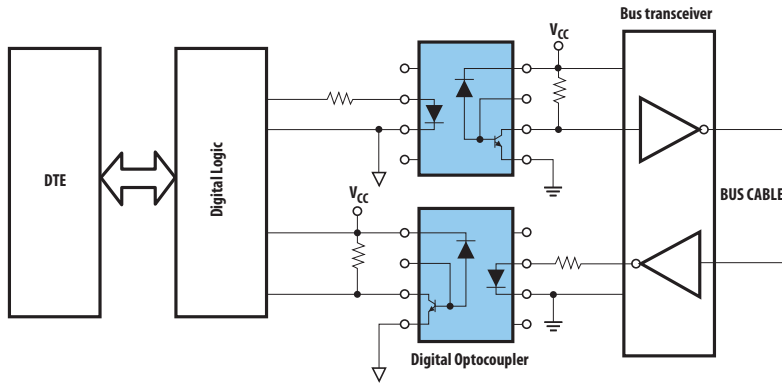

Figure 9 – Serial Bus Interface Isolation Block Diagram



Serial Bus Interface Isolation RS-232, RS-422 and RS-485

Avago's digital optocouplers offer speeds from 100 kBd to 10 MBd/15 MBd (5 V/3.3 V) and are used in serial digital data transmission and communications, such as RS-232, RS-422 and RS-485 (Figure 9). Two such devices, HCPL-063L (3.3 V, dual channels, 15 MBd) and HCPL-0661 (5V, dual channels, 10 MBd), provide isolation between bus transceivers and other digital logic with bus controllers. Both parts meet serial data communication requirements such as noise elimination (due to high CMR functions) and low power consumption (due to low drive current) with high insulation voltage. Avago's digital optocouplers are offered in DIP8 packages (HCPL-263L/HCPL-4661).

Fieldbus Networks Profibus/RS-485 and DeviceNet/CAN

Avago's high-speed CMOS optocouplers are commonly used in Industrial Fieldbus applications with speeds of up to 50 MBd. These optocouplers use the latest CMOS IC technology to achieve outstanding performance with very low power consumption. In the isolated multipoint transmission application circuit shown in Figure 10, two different optoisolators are utilized (HCPL-0721 and HCPL-061N). Benefits of this configuration include low input drive current that maximizes Light Emitting Diode (LED) lifetime/reliability and optimized speed for Profibus and RS-485 applications.



Figure 10 – Fieldbus Network Profibus Block Diagram

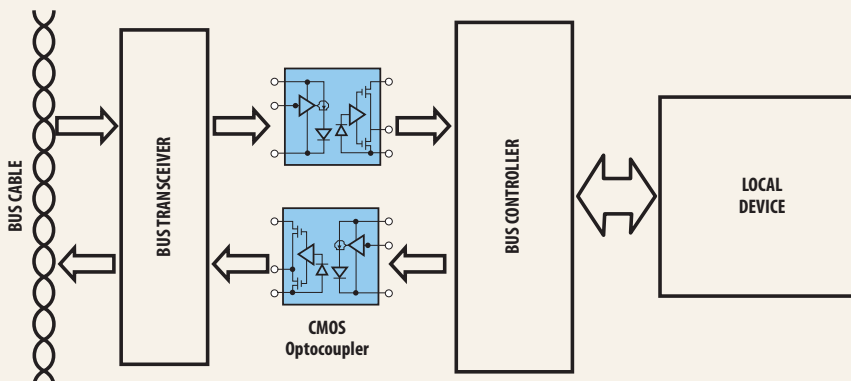

About Avago Technologies

Avago Technologies is a leading global supplier of analog, mixed-signal and optoelectronic components and subsystems. The company serves three primary product categories comprising optoelectronics, RF/microwave components and enterprise ASICs.

Avago Technologies' product solutions include fiber optic transceivers and ICs for storage, computing and networking. For mobile handsets, Avago offers RF components, infrared transceivers, light and proximity sensors, CMOS image sensors, and LEDs for camera flash as well as keypad and display backlighting. Avago's optoelectronics solutions include a broad range of LEDs, the world's most comprehensive line of isolation devices, an illumination and color management system for backlighting LCD flat-panel TVs, motion control components for office automation and industrial systems, optical navigation sensors for computer mice, and fiber optics transmitters and receivers for industrial and automotive applications.

Avago Technologies combines the capabilities and track record of an established global leader with the vigor and responsiveness of a startup. Avago's heritage of technical innovation dates back 40 years to its Agilent/Hewlett-Packard roots. During those years, the company amassed more than 2,000 patents and applications, and a reputation for innovation, quality and superior customer service.

For product information and a complete list of distributors, please go to our web site:

www.avagotech.com
www.avagotech.com/optocouplers

Avago, Avago Technologies, and the A logo are trademarks of Avago Technologies limited in the United States and other countries.
Data subject to change. Copyright © 2006 Avago Technologies
AV00-0074EN 8/23/06

