

## ASCQxx60 Series

### Mono Color Top-Mount Lens PLCC-4

---

#### Description

The Broadcom<sup>®</sup> ASCQxx60 series is a PLCC-4 package with a 3.5 mm × 3.15 mm footprint. The LEDs are made with an advanced optical grade epoxy for superior performance in outdoor sign applications. The black outer appearance enables better display contrast without sacrificing the brightness.

To facilitate easy pick-and-place assembly, the LEDs are packed in tape and reel form. Every reel is shipped in single intensity and color bin to ensure uniformity.

#### Features

- Available in Red, Orange, and Amber
- Nominal viewing angle: 55°
- Frosted lens with white surface and black outer appearance
- MSL 3

#### Applications

- Sign and symbol display
- Variable message signs

**CAUTION!** This LED is ESD sensitive. Observe appropriate precautions during handling and processing. Refer to the *Premium InGaN LEDs Safety Handling Fundamentals ESD Application Note AN-1142* for additional details.

Figure 1: Package Drawing for Black Outer Appearance (BOA) ASCQFx60 Series

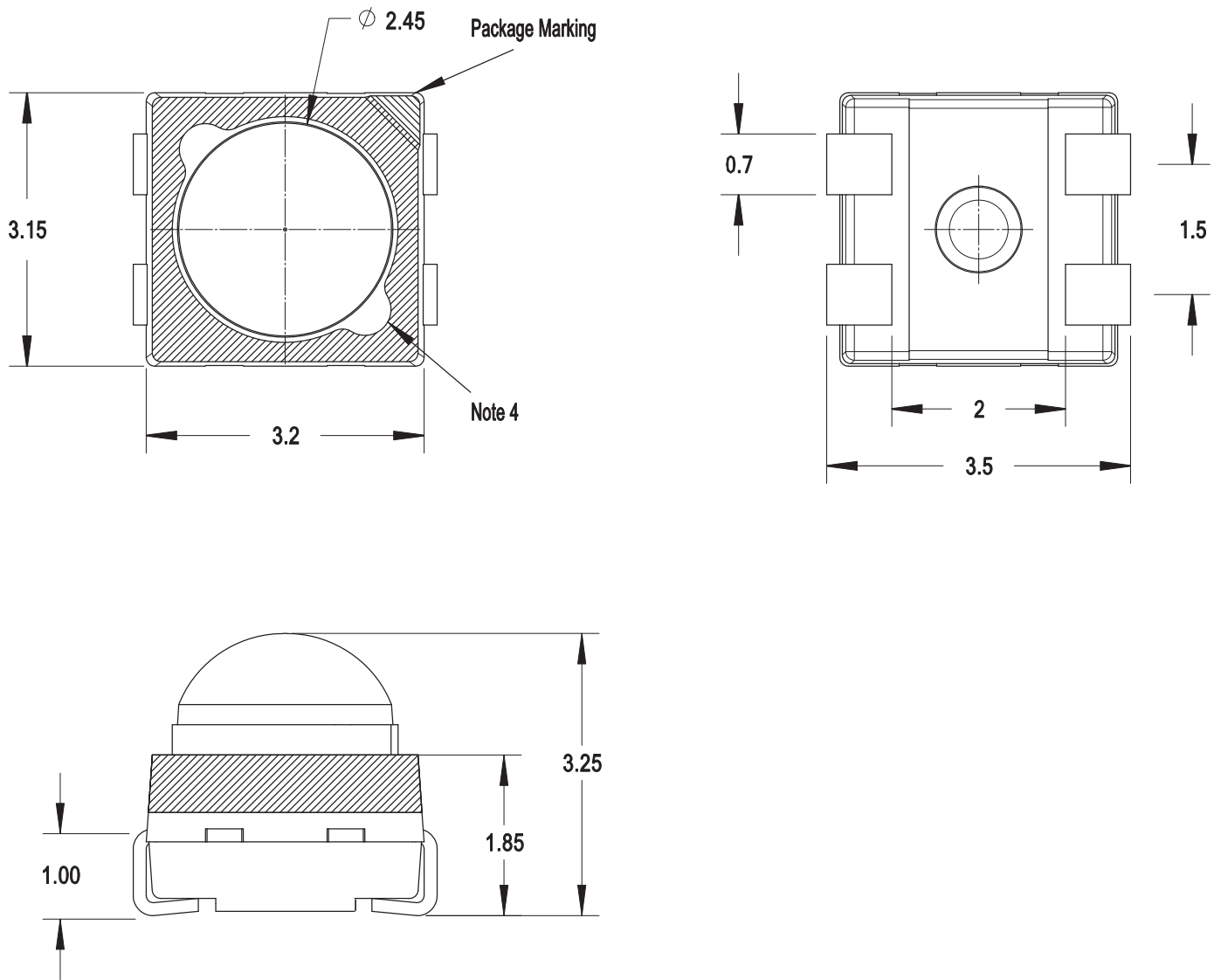

**NOTE:**

1. All dimensions are in millimeters (mm).
2. Tolerance is  $\pm 0.20$  mm unless otherwise specified.
3. Terminal finish = silver plating.
4. The molding feature can be either on the left or right side of the lens.

Figure 2: Package Drawing for White Surface ASCQDx60 Series

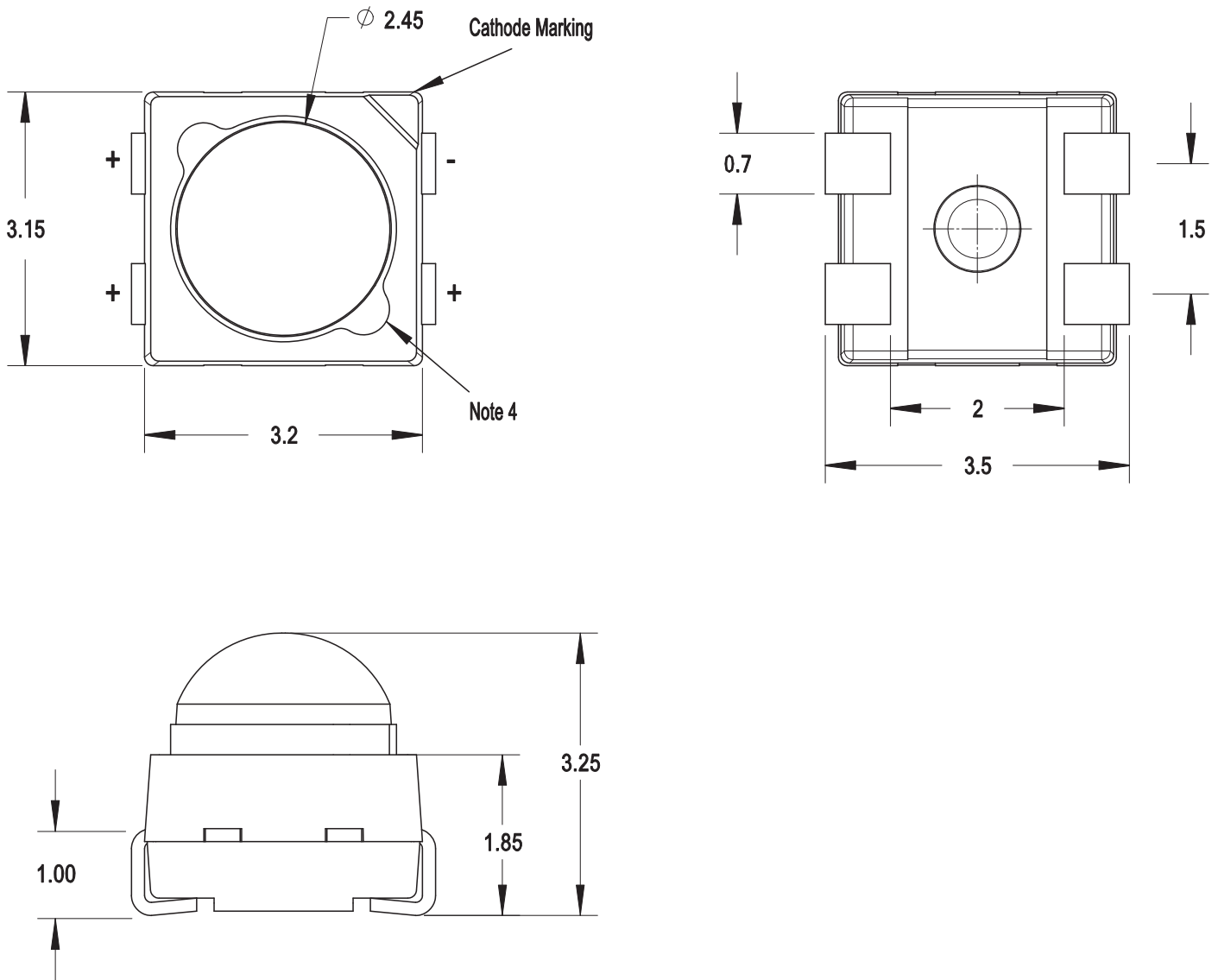

**NOTE:**

1. All dimensions are in millimeters (mm).
2. Tolerance is  $\pm 0.20$  mm unless otherwise specified.
3. Terminal finish = silver plating.
4. The molding feature can be either on the left or right side of the lens.

## Device Selection Guide ( $T_J = 25^\circ\text{C}$ )

| Parameters           | Appearance          | Color  | Luminous Intensity, $I_V$<br>(mcd) <sup>a, b</sup> |       | Dominant Wavelength,<br>$\lambda_d$ (nm) <sup>c</sup> |      | Test Current<br>(mA) |
|----------------------|---------------------|--------|--|-------|---|------|----------------------|
|                      |                     |        | Min.   | Max.  | Min.  | Max. |                      |
| ASCQFR60-BZ211R0R105 | Black Outer Surface | Red    | 5600   | 9000  | 618   | 628  | 50                   |
| ASCQFJ60-B1112J1J505 | Black Outer Surface | Orange | 7150   | 11250 | 599   | 610  | 50                   |
| ASCQFA60-B1112A2A305 | Black Outer Surface | Amber  | 7150   | 11250 | 587   | 593  | 50                   |
| ASCQDR60-BZ211R0R105 | White Surface       | Red    | 5600   | 9000  | 618   | 628  | 50                   |
| ASCQDJ60-B1112J1J505 | White Surface       | Orange | 7150   | 11250 | 599   | 610  | 50                   |
| ASCQDA60-B1112A2A305 | White Surface       | Amber  | 7150   | 11250 | 587   | 593  | 50                   |

- a. The luminous intensity,  $I_V$ , is measured at the mechanical axis of the package and it is tested with a single current pulse condition. The actual peak of the spatial radiation pattern may not be aligned with the axis.
- b. Tolerance is  $\pm 12\%$ .
- c. The dominant wavelength,  $\lambda_d$ , is derived from the CIE Chromaticity Diagram and represents the perceived color of the device.

## Absolute Maximum Ratings

| Parameters                        | Red  | Orange | Amber | Unit             |
|-----------------------------------|--|--------|-------|------------------|
| DC Forward Current <sup>a</sup>   | 70   | 70     | 70    | mA               |
| Peak Forward Current <sup>b</sup> | 100  | 100    | 100   | mA               |
| Power Dissipation                 | 185.5                                      | 192.5  | 192.5 | mW               |
| Reverse Voltage                   | Not recommended for reverse bias operation |        |       |                  |
| LED Junction Temperature          | 110  | 110    | 110   | $^\circ\text{C}$ |
| Operating Temperature Range       | -40 to +100                                |        |       | $^\circ\text{C}$ |
| Storage Temperature Range         | -40 to +100                                |        |       | $^\circ\text{C}$ |

- a. Derate linearly as shown in [Figure 11](#).
- b. Duty factor = 10%, frequency = 1 kHz,  $T_A = 25^\circ\text{C}$ .

## Optical and Electrical Characteristics ( $T_J = 25^\circ\text{C}$ )

| Parameters  | Min.  | Typ.  | Max.  | Unit               | Test Condition                |
|---|-------|-------|-------|--------------------|-------------------------------|
| Dominant Wavelength, $\lambda_d$ <sup>a</sup>     |       |       |       |                    |                               |
| Red   | 618.0 | 623.0 | 628.0 | nm                 | $I_F = 50\text{ mA}$          |
| Orange  | 599.0 | 605.0 | 610.0 | nm                 | $I_F = 50\text{ mA}$          |
| Amber   | 587.0 | 590.0 | 593.0 | nm                 | $I_F = 50\text{ mA}$          |
| Peak Wavelength, $\lambda_p$                      |       |       |       |                    |                               |
| Red   | —     | 632.0 | —     | nm                 | $I_F = 50\text{ mA}$          |
| Orange  | —     | 611.0 | —     | nm                 | $I_F = 50\text{ mA}$          |
| Amber   | —     | 593.0 | —     | nm                 | $I_F = 50\text{ mA}$          |
| Forward Voltage, $V_F$ <sup>b</sup>               |       |       |       |                    |                               |
| Red   | 2.00  | 2.20  | 2.65  | V                  | $I_F = 50\text{ mA}$          |
| Orange  | 2.00  | 2.40  | 2.75  | V                  | $I_F = 50\text{ mA}$          |
| Amber   | 2.10  | 2.40  | 2.75  | V                  | $I_F = 50\text{ mA}$          |
| Reverse Voltage, $V_R$ <sup>c</sup>               | 4.00  | —     | —     | V                  | $I_R = 10\text{ }\mu\text{A}$ |
| Thermal Resistance, $R_{\theta J-S}$ <sup>d</sup> |       |       |       |                    |                               |
| Red   | —     | 150.0 | —     | $^\circ\text{C/W}$ | LED junction to pin           |
| Orange  | —     | 150.0 | —     | $^\circ\text{C/W}$ | LED junction to pin           |
| Amber   | —     | 150.0 | —     | $^\circ\text{C/W}$ | LED junction to pin           |

a. The dominant wavelength,  $\lambda_d$ , is derived from the CIE Chromaticity Diagram and represents the perceived color of the device.

b. Forward voltage tolerance is  $\pm 0.1\text{V}$ .

c. Indicates product final test condition. Long-term reverse bias is not recommended.

d. Thermal resistance from the LED junction to the pin.

# Part Numbering System

A S C Q 

|                |                |
|----------------|----------------|
| x <sub>1</sub> | x <sub>2</sub> |
|----------------|----------------|

 6 0 - 

|                |                |                |                |                |                |                |                 |                 |                 |                 |
|----------------|----------------|----------------|----------------|----------------|----------------|----------------|-----------------|-----------------|-----------------|-----------------|
| x <sub>3</sub> | x <sub>4</sub> | x <sub>5</sub> | x <sub>6</sub> | x <sub>7</sub> | x <sub>8</sub> | x <sub>9</sub> | x <sub>10</sub> | x <sub>11</sub> | x <sub>12</sub> | x <sub>13</sub> |
|----------------|----------------|----------------|----------------|----------------|----------------|----------------|-----------------|-----------------|-----------------|-----------------|

| Code                            | Description           | Option  |                              |
|---------------------------------|-----------------------|---|------------------------------|
| x <sub>1</sub>                  | Appearance            | D   | White Surface                |
|                                 |                       | F   | Black Outer Appearance (BOA) |
| x <sub>2</sub>                  | Color                 | A   | Amber                        |
|                                 |                       | J   | Orange                       |
|                                 |                       | R   | Red                          |
| x <sub>3</sub>                  | Die Technology        | B   | AllnGaP                      |
| x <sub>4</sub> x <sub>5</sub>   | Minimum Intensity Bin | Refer to <a href="#">Intensity Bin Limits (CAT)</a> . |                              |
| x <sub>6</sub> x <sub>7</sub>   | Maximum Intensity Bin |   |                              |
| x <sub>8</sub> x <sub>9</sub>   | Minimum Color Bin     | Refer to <a href="#">Color Bin Limits (BIN)</a> .     |                              |
| x <sub>10</sub> x <sub>11</sub> | Maximum Color Bin     |   |                              |
| x <sub>12</sub>                 | Forward Voltage Bin   | 0   | Full Distribution            |
| x <sub>13</sub>                 | Test Current          | 5   | 50 mA                        |

## Bin Information

### Intensity Bin Limits (CAT)

| Bin ID | Luminous Intensity, $I_V$ (mcd) |       |
|--------|---------------------------------|-------|
|        | Min.                            | Max.  |
| Z2     | 5600                            | 7150  |
| 11     | 7150                            | 9000  |
| 12     | 9000                            | 11250 |

Tolerance =  $\pm 12\%$ .

### Forward Voltage Bin Limits ( $V_F$ )

| Bin ID | Forward Voltage, $V_F$ (V) |      |
|--------|----------------------------|------|
|        | Min.                       | Max. |
| VA     | 2.00                       | 2.15 |
| VB     | 2.10                       | 2.25 |
| VC     | 2.20                       | 2.35 |
| VD     | 2.30                       | 2.45 |
| VE     | 2.40                       | 2.55 |
| VG     | 2.50                       | 2.65 |
| VH     | 2.60                       | 2.75 |

Tolerance =  $\pm 0.1V$ .

### Color Bin Limits (BIN)

| Bin ID        | Dominant Wavelength, $\lambda_d$ (nm) |       |
|---------------|---------------------------------------|-------|
|               | Min.                                  | Max.  |
| <b>Red</b>    |                                       |       |
| R0            | 618.0                                 | 623.0 |
| R1            | 623.0                                 | 628.0 |
| <b>Orange</b> |                                       |       |
| J1            | 599.0                                 | 602.0 |
| J2            | 601.0                                 | 604.0 |
| J3            | 603.0                                 | 606.0 |
| J4            | 605.0                                 | 608.0 |
| J5            | 607.0                                 | 610.0 |
| <b>Amber</b>  |                                       |       |
| A2            | 587                                   | 590   |
| A3            | 590                                   | 593   |

Tolerance =  $\pm 1.0$  nm.

Example of bin information on reel and packaging label:

CAT: 22           – Intensity bin 22  
 BIN: A2           – Amber color bin A2

Figure 3: Spectral Power Distribution

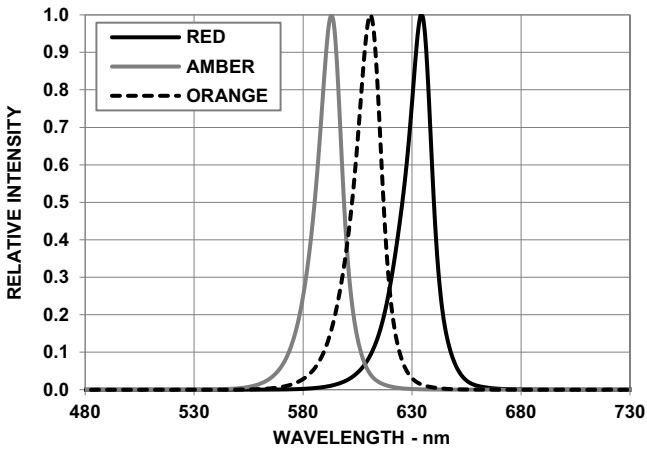

Figure 4: Forward Current vs. Forward Voltage

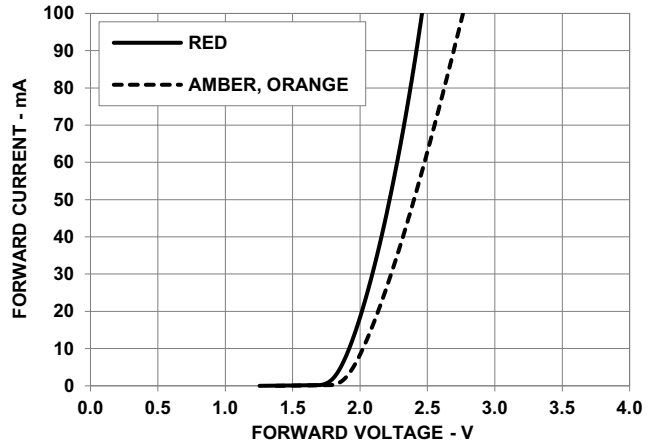

Figure 5: Relative Luminous Intensity vs. Mono Pulse Current

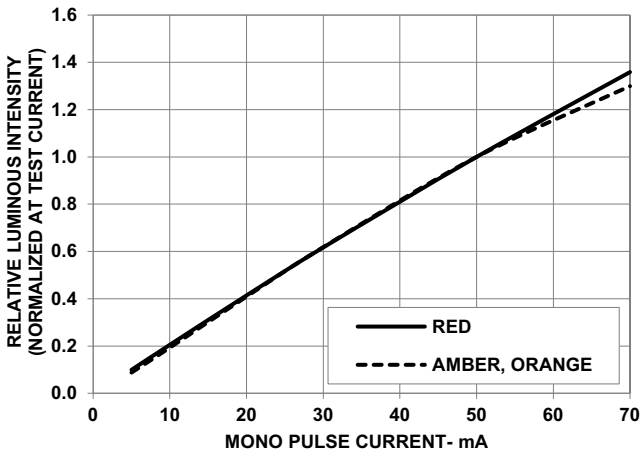

Figure 6: Dominant Wavelength Shift vs. Mono Pulse Current

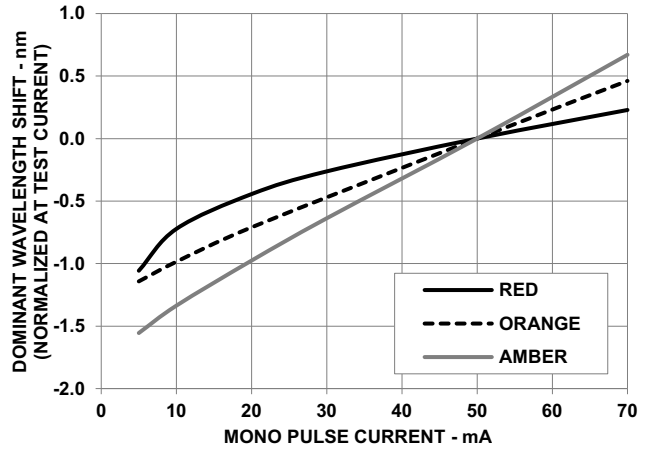

Figure 7: Radiation Pattern

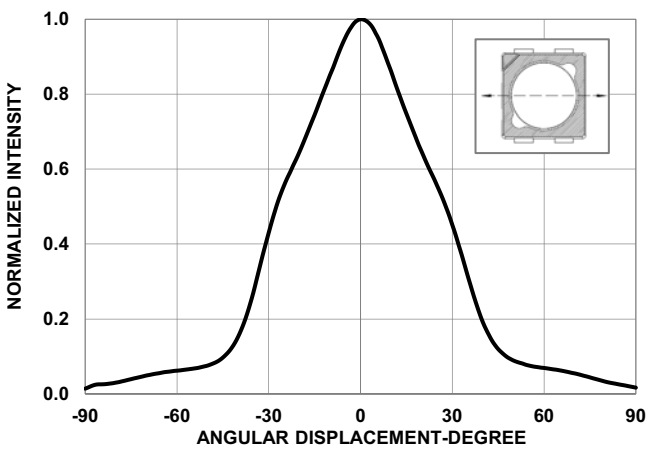

Figure 8: Relative Light Output vs. Junction Temperature

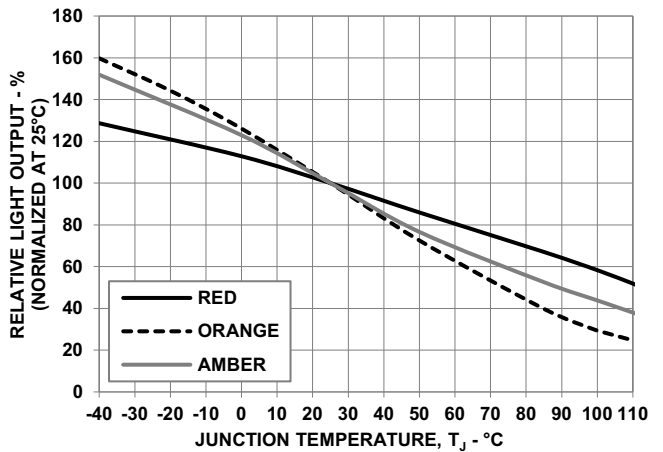



Figure 9: Forward Voltage Shift vs. Junction Temperature

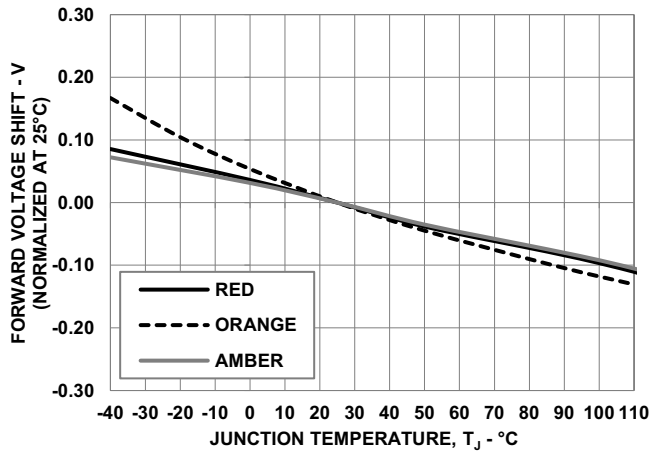

Figure 10: Dominant Wavelength Shift vs. Junction Temperature

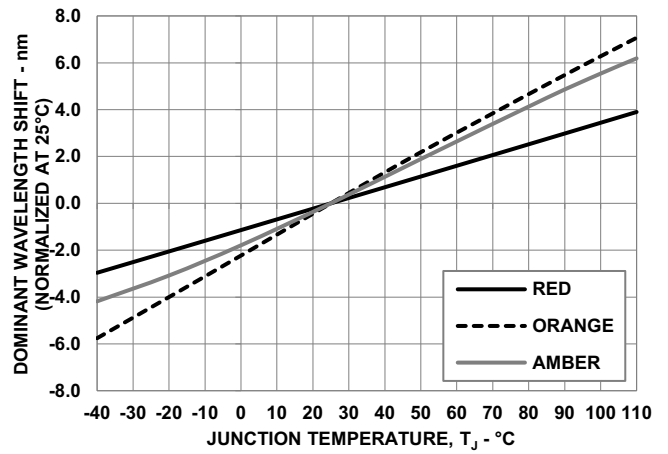

Figure 11: Maximum Forward Current vs. Temperature

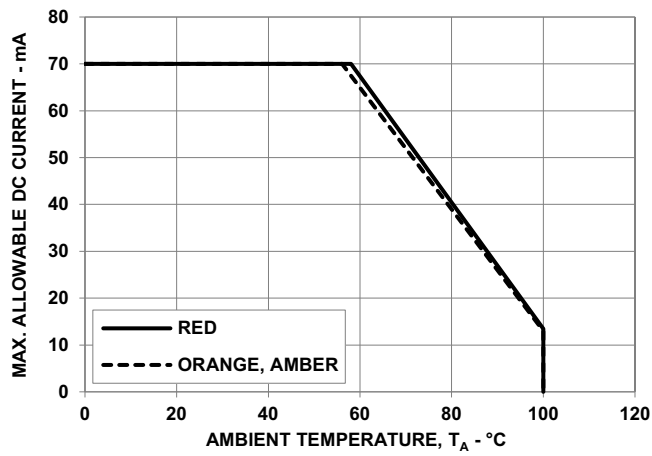
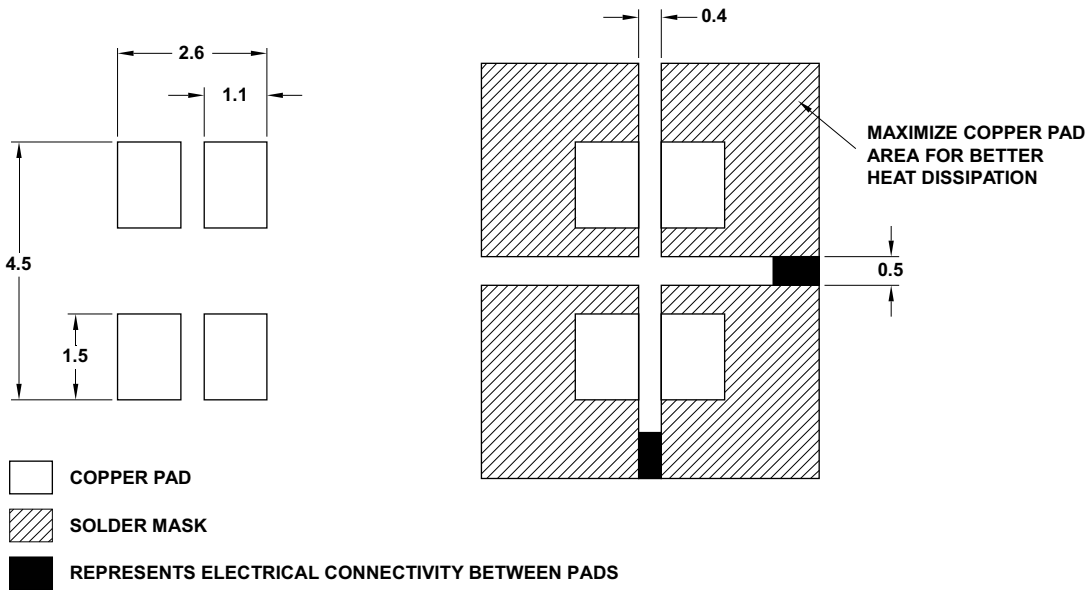
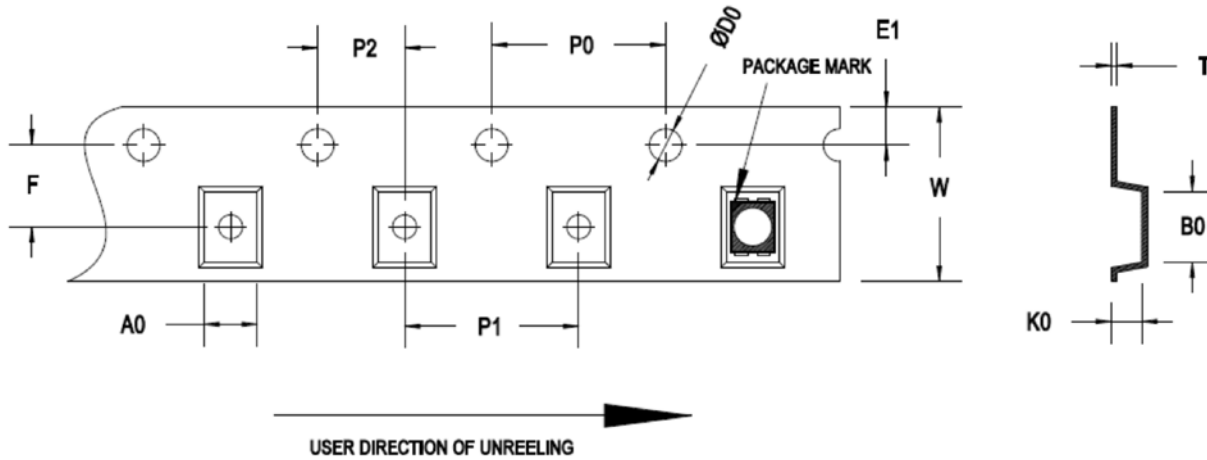

Figure 12: Recommended Soldering Pad Pattern



NOTE: All dimensions are in millimeters (mm).

Figure 13: Carrier Tape Drawing



| F        | E1         | P0        | P1       | P2        | DO        | W          |
|----------|------------|-----------|----------|-----------|-----------|------------|
| 5.5 ±0.1 | 1.75 ±0.10 | 4.0 ±0.10 | 8.0 ±0.1 | 2.0 ±0.05 | 1.50 +0.1 | 12.0 ±0.30 |

| T         | B0       | A0        | K0        |
|-----------|----------|-----------|-----------|
| 0.3 ±0.05 | 3.7 ±0.1 | 3.35 ±0.1 | 3.30 ±0.1 |

NOTE:

1. All dimensions are in millimeters (mm).
2. LED quantity per reel is 2000 pieces.

Figure 14: Reel Drawing

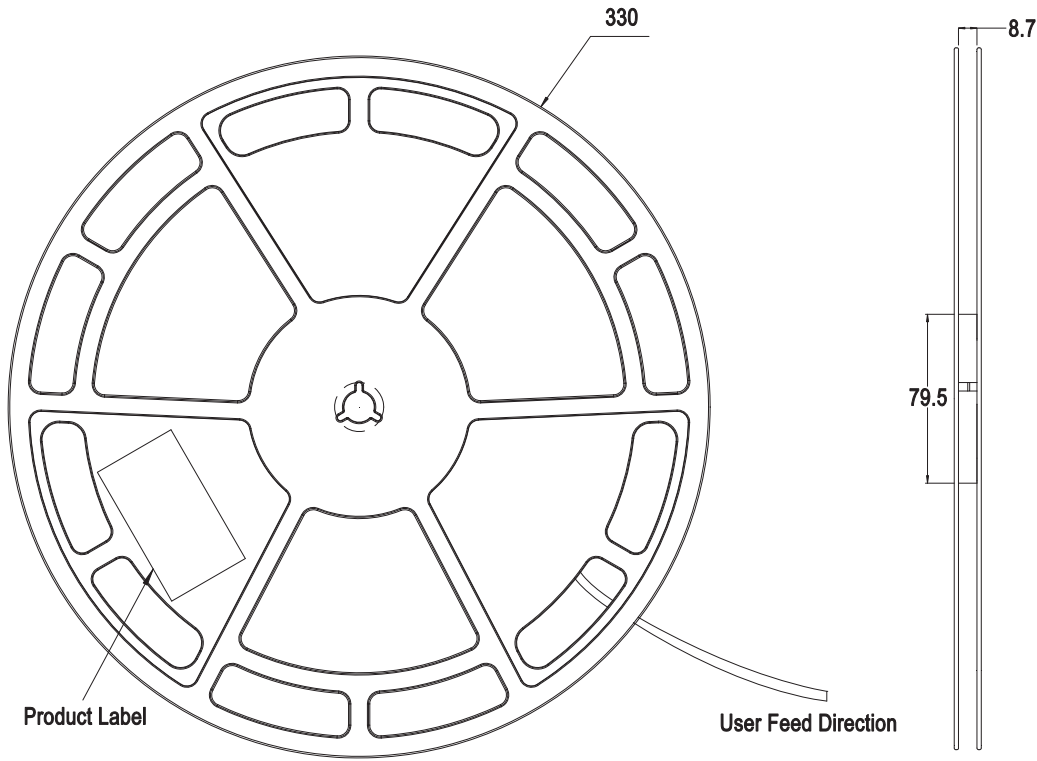

**NOTE:** All dimensions are in millimeters (mm).

# Precautionary Notes

## Soldering

- Do not perform reflow soldering more than twice. Observe necessary precautions of handling moisture-sensitive devices as stated in the following section.
- Do not apply any pressure or force on the LED during reflow and after reflow when the LED is still hot.
- Use reflow soldering to solder the LED. Use hand soldering only for rework if unavoidable, but it must be strictly controlled to the following conditions:
  - Soldering iron tip temperature = 315°C maximum.
  - Soldering duration = 3 seconds maximum.
  - Number of cycles = 1 only.
  - Power of soldering iron = 50W maximum.
- Do not touch the LED package body with the soldering iron except for the soldering terminals because it may cause damage to the LED.
- Confirm beforehand whether the functionality and performance of the LED is affected by soldering with hand soldering.

Figure 15: Recommended Lead-Free Reflow Soldering Profile

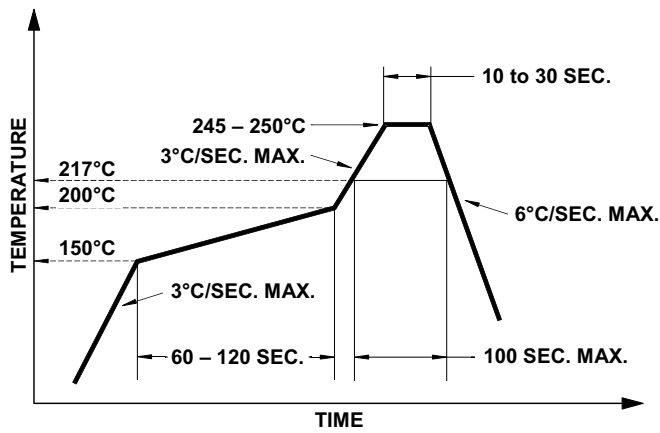

## Handling Precautions

For automated pick and place, Broadcom has tested nozzle size with ID = 2.65 mm to work with this LED. However, due to the possibility of variations in other parameters such as pick-and-place machine maker/model, and other settings of the machine, verify that the selected nozzle performs as per requirements.

Figure 16: Recommended LED Placement

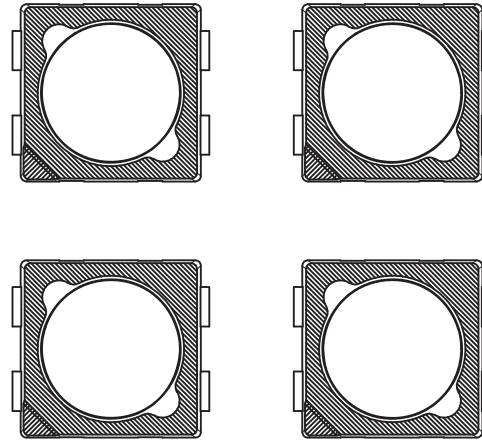

## Handling of Moisture-Sensitive Devices

This product has a Moisture Sensitive Level 3 rating per JEDEC J-STD-020. Refer to Broadcom Application Note AN5305, *Handling of Moisture Sensitive Surface Mount Devices*, for additional details and a review of proper handling procedures.

- Before use:
  - An unopened moisture barrier bag (MBB) can be stored at <math>40^{\circ}\text{C}/90\% \text{ RH}</math> for 12 months. If the actual shelf life has exceeded 12 months and the humidity indicator card (HIC) indicates that baking is not required, it is safe to reflow the LEDs per the original MSL rating.
  - Do not open the MBB prior to assembly (for example, for IQC). If unavoidable, the MBB must be properly resealed with fresh desiccant and HIC. The exposed duration must be taken in as floor life.
- Control after opening the MBB:
  - Read the HIC immediately upon opening of the MBB.
  - Keep the LEDs at <math>30^{\circ}\text{C}/60\% \text{ RH}</math> at all times, and complete all high temperature-related processes, including soldering, curing or rework within 168 hours.
- Control for unfinished reel:
 

Store unused LEDs in a sealed MBB with desiccant or a desiccator at <math>5\% \text{ RH}</math>.
- Control of assembled boards:
 

If the PCB soldered with the LEDs is to be subjected to other high-temperature processes, store the PCB in a sealed MBB with desiccant or desiccator at <math>5\% \text{ RH}</math> to ensure that all LEDs have not exceeded their floor life of 168 hours.
- Baking is required if the following conditions exist:
  - The HIC indicator indicates a change in color for 10% and 5%, as stated on the HIC.
  - The LEDs are exposed to conditions of <math>30^{\circ}\text{C}/60\% \text{ RH}</math> at any time.
  - The LED's floor life exceeded 168 hours.

The recommended baking condition is  $65^{\circ}\text{C} \pm 5^{\circ}\text{C}$  for 24 hours.

Baking can only be done once.

- Storage:
 

The soldering terminals of these Broadcom LEDs are silver plated. If the LEDs are exposed in ambient environments for too long, the silver plating might be oxidized, thus affecting its solderability performance. As such, keep unused LEDs in a sealed MBB with desiccant or in a desiccator at <math>5\% \text{ RH}</math>.

## Application Precautions

- The drive current of the LED must not exceed the maximum allowable limit across temperature as stated in the data sheet. Constant current driving is recommended to ensure consistent performance.
- The circuit design must cater to the entire range of forward voltage ( $V_F$ ) of the LEDs to ensure the intended drive current can always be achieved.
- The LED exhibits slightly different characteristics at different drive currents, which may result in a larger variation of performance (such as intensity, wavelength, and forward voltage). Set the application current as close as possible to the test current to minimize these variations.
- The LED is not intended for reverse bias. Use other appropriate components for such purposes. When driving the LED in matrix form, ensure that the reverse bias voltage does not exceed the allowable limit of the LED.
- Avoid rapid changes in ambient temperatures, especially in high-humidity environments because they cause condensation on the LED.
- If the LED is intended to be used in a harsh or an outdoor environment, protect the LED against damages caused by rain water, water, dust, oil, corrosive gases, external mechanical stresses, and so on.

## Thermal Management

The optical, electrical, and reliability characteristics of the LED are affected by temperature. Keep the junction temperature ( $T_J$ ) of the LED below the allowable limit at all times.  $T_J$  can be calculated as follows:

$$T_J = T_A + R_{\theta J-A} \times I_F \times V_{Fmax}$$

where:

$$T_A = \text{Ambient temperature (}^\circ\text{C)}$$

$$R_{\theta J-A} = \text{Thermal resistance from LED junction to ambient (}^\circ\text{C/W)}$$

$$I_F = \text{Forward current (A)}$$

$$V_{Fmax} = \text{Maximum forward voltage (V)}$$

The complication of using this formula lies in  $T_A$  and  $R_{\theta J-A}$ . Actual  $T_A$  is sometimes subjective and hard to determine.  $R_{\theta J-A}$  varies from system to system depending on design and is usually not known.

Another way of calculating  $T_J$  is by using the solder point temperature,  $T_S$  as follows:

$$T_J = T_S + R_{\theta J-S} \times I_F \times V_{Fmax}$$

where:

$$T_S = \text{LED solder point temperature as shown in the following figure (}^\circ\text{C)}$$

$$R_{\theta J-S} = \text{Thermal resistance from junction to solder point (}^\circ\text{C/W)}$$

$$I_F = \text{Forward current (A)}$$

$$V_{Fmax} = \text{Maximum forward voltage (V)}$$

Figure 17: Solder Point Temperature on PCB

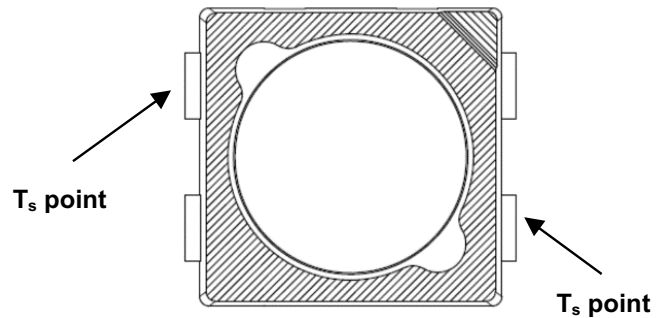

$T_S$  can be easily measured by mounting a thermocouple on the soldering joint as shown in preceding figure, while  $R_{\theta J-S}$  is provided in the data sheet. Verify the  $T_S$  of the LED in the final product to ensure that the LEDs are operating within all maximum ratings stated in the data sheet.

## Eye Safety Precautions

LEDs may pose optical hazards when in operation. Do not look directly at operating LEDs because it might be harmful to the eyes. For safety reasons, use appropriate shielding or personal protective equipment.

## Disclaimer

Broadcom's products and software are not specifically designed, manufactured, or authorized for sale as parts, components, or assemblies for the planning, construction, maintenance, or direct operation of a nuclear facility or for use in medical devices or applications. The customer is solely responsible, and waives all rights to make claims against Broadcom or its suppliers, for all loss, damage, expense, or liability in connection with such use.

Copyright © 2022-2024 Broadcom. All Rights Reserved. The term "Broadcom" refers to Broadcom Inc. and/or its subsidiaries. For more information, go to [www.broadcom.com](http://www.broadcom.com). All trademarks, trade names, service marks, and logos referenced herein belong to their respective companies.

Broadcom reserves the right to make changes without further notice to any products or data herein to improve reliability, function, or design. Information furnished by Broadcom is believed to be accurate and reliable. However, Broadcom does not assume any liability arising out of the application or use of this information, nor the application or use of any product or circuit described herein, neither does it convey any license under its patent rights nor the rights of others.



Lead (Pb) Free  
RoHS Compliant