

## AR25DP

### Smart Programmable 25-Bit Absolute Encoder ASIC in a Dust Protection Package

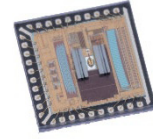

#### Overview

The Broadcom<sup>®</sup> AR25DP is a miniature absolute encoder ASIC that is designed to meet the growing demand for space-constraint applications. Utilizing advanced reflective optical encoding technology, the AR25DP series delivers high positional accuracy through a correction algorithm that magnetic encoders cannot achieve.

The AR25DP encoder is a one-chip solution that supports a wide range of overall diameters, ranging from 30 mm to 55 mm. The AR25DP also supports through-hole solutions up to a 30-mm inner diameter. User-programmable resolutions range from 15-bit to 25-bit single-turn absolute outputs. Additionally, the AR25DP provides differential analog sine/cosine or digital incremental ABIUVW signals with configurable counts per revolution (CPR) and pole-pair settings. Its state-of-the-art auto-calibration feature simplifies integration into end-user systems.

The AR25DP series is compatible with the Broadcom proprietary battery-less Energy-Harvesting Multi-Turn (EHMT) solution. It also supports alternative multi-turn mechanisms, such as gear-based systems and battery-backed counters, via a dedicated multi-turn (MT) interface port.

For power, the ASIC supports dual-mode operation at either 3.3V or 5V, making it suitable for versatile integration into a wide range of industrial applications. It operates reliably across a wide temperature range of  $-40^{\circ}\text{C}$  to  $125^{\circ}\text{C}$ , ideal for most industrial environments. To enhance design flexibility, the AR25DP offers a variety of user-selectable communication protocols. Supported protocols include Encoder Serial Link (ESL), RS-485 half-duplex, SSI, BiSS-C, and SPI 4-wire.

**CAUTION!** Except as expressly indicated in writing, this product is not designed or warranted to be suitable for use in safety-related or life critical applications where its failure or malfunction can reasonably be expected to result in injury, death, or severe equipment damage. Customers are solely responsible for determining the suitability of this product for its intended application and solely liable for all loss, damage, expense, or liability in connection with such use.

#### Features

- Miniature surface-mount QFN package: 6 mm (L) × 6 mm (W) × 0.7 mm (H)
- User-programmable resolutions:
  - Absolute output: 15 bits to 25 bits
  - Incremental (ABI) output: 1 CPR to  $2^{20}$  CPR
  - Commutation signals (UVW): 1 to 32 pole pairs
- High temperature range of  $-40^{\circ}\text{C}$  to  $125^{\circ}\text{C}$
- Dual-mode operating voltages of 3.3V and 5V
- Multi-turn integration: EHMT, gear, or battery backup
- Optical radius (ROP) flexibility: Blind hollow or through hole
  - Code-wheel ID up to 30 mm
- Built-in line transceiver for protocol with selectable driveability strength
- Easy signal optimization with calibration built in
- Accuracy calibration with a constant speed rotation or with a reference encoder
- Selectable communication protocols:
  - RS-485 (2.5/5/10 Mb/s)
  - ESL (2.5/5/10 Mb/s)
  - SSI 2-wire (up to 10 MHz)
  - SPI 4-wire (up to 10 MHz)
  - BiSS-C (up to 10 MHz)
- Up to 128 Kb of external user-accessible EEPROM memory
- Built-in temperature sensor
- RoHS compliant

# Applications

- Robotic automation and engineering
- Factory automation and drones
- Medical and dentistry devices and equipment
- High-accuracy portable and handheld devices
- Miniature motors, servo motors, and linear actuators
- Through-shaft motors, gear motors, and speed reducers

**NOTE:** The AR25DP series encoders are not halogen-free products.

# Functional Description

**Figure 1: AR25DP Block Diagram**

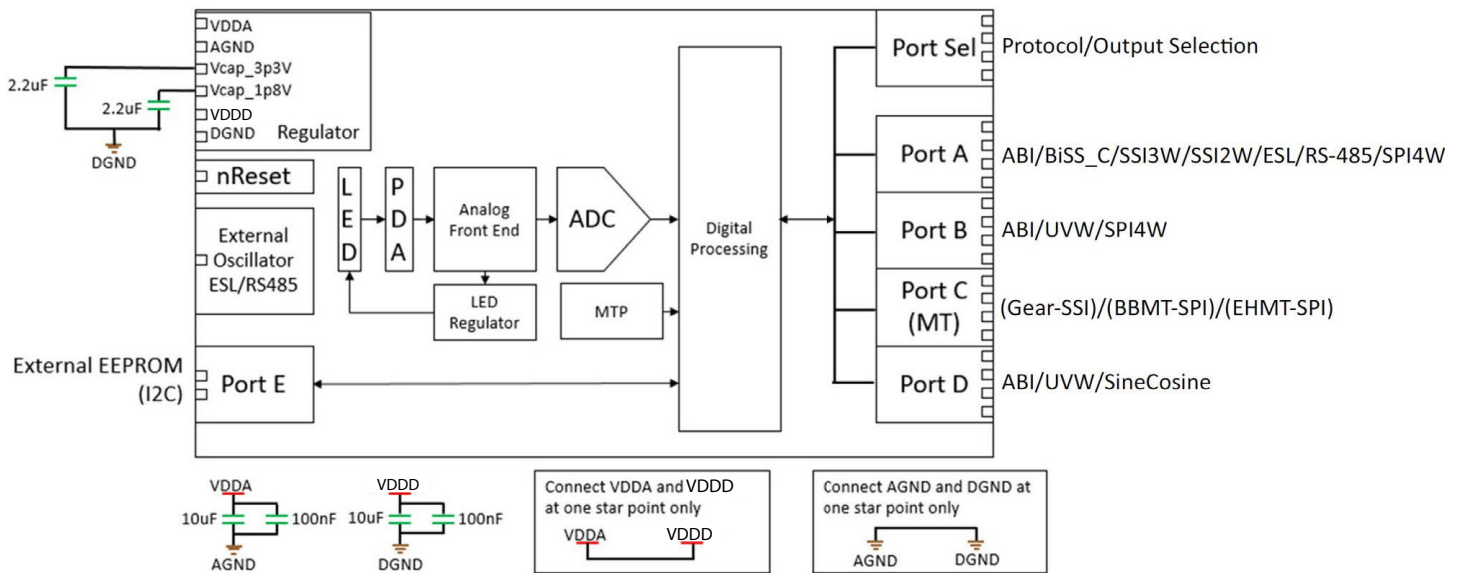

**Figure 2: AR25DP External Oscillator Connection Diagram**

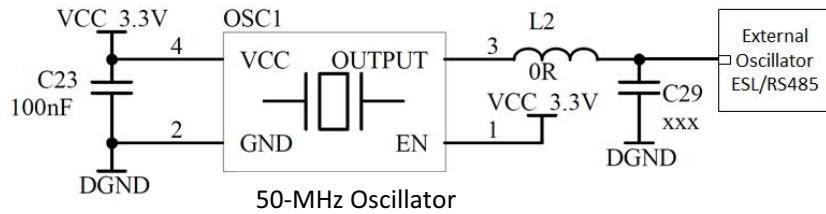

**NOTE:** For 5V applications, OSC1 Vcc 3.3V can be supplied from the Vcap\_3p3V pin.

Figure 3: AR25DP External EEPROM Connection Diagram

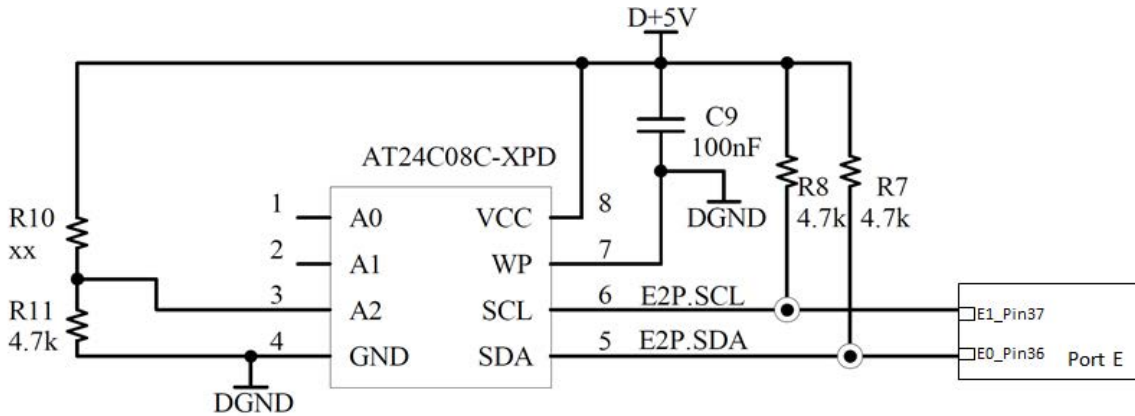
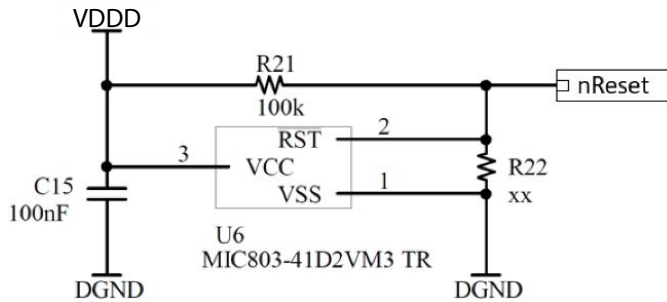

Figure 4: AR25DP External nReset Connection Diagram



**NOTE:** For more design details, refer to the AR25DP series application note.

## Selection Pin Recommendations

Figure 5: Example of a High and Low Selection Circuit

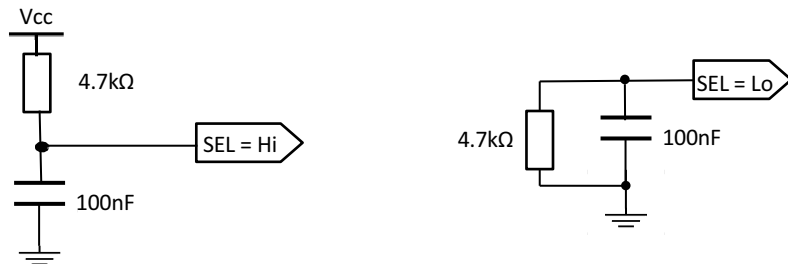

**NOTE:** It is recommended to include capacitors at the SEL pins to prevent or eliminate any unwanted disturbance or signal coupling that could impact the operating mode selection of the AR25DP encoders and lead to unwanted behavior of the encoder device.

## Voltage Divider Circuit

Figure 6: Example of a Voltage Divider Circuit

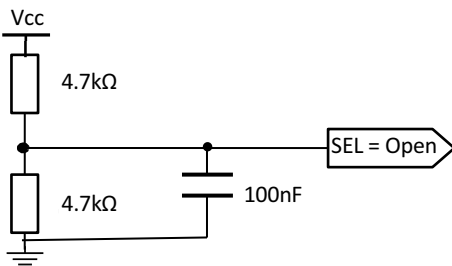

**NOTE:** It is recommended to use  $2 \times 4.7\text{-k}\Omega$  resistors (VDDA-GND).

## I/O Pins Considerations

### I/O Contention

Do not apply voltage or current to the I/O pins before the AR25DP encoder is powered up. There are ESD diodes and I/O multiplexing in the ASIC device pads, and any undue voltage or current going into the device can partially power up the device and bring it to an unknown state or cause an undue collection of charges prior to a proper power-up. Proper power sequencing is required to ensure proper operation of the encoder device.

### Output Load

The AR25DP encoder is designed for a wide range of applications, and as such, it provides different modes of functional selections. Carefully consider the external load to prevent unwanted overshoot, ringing, and even device instability. Select a proper RC load at the output for the mode selected in the application. It is generally not recommended to directly drive a capacitive or inductive load.

# Mechanical Dimensions

Figure 7: Overall Package Dimensions and Pinout

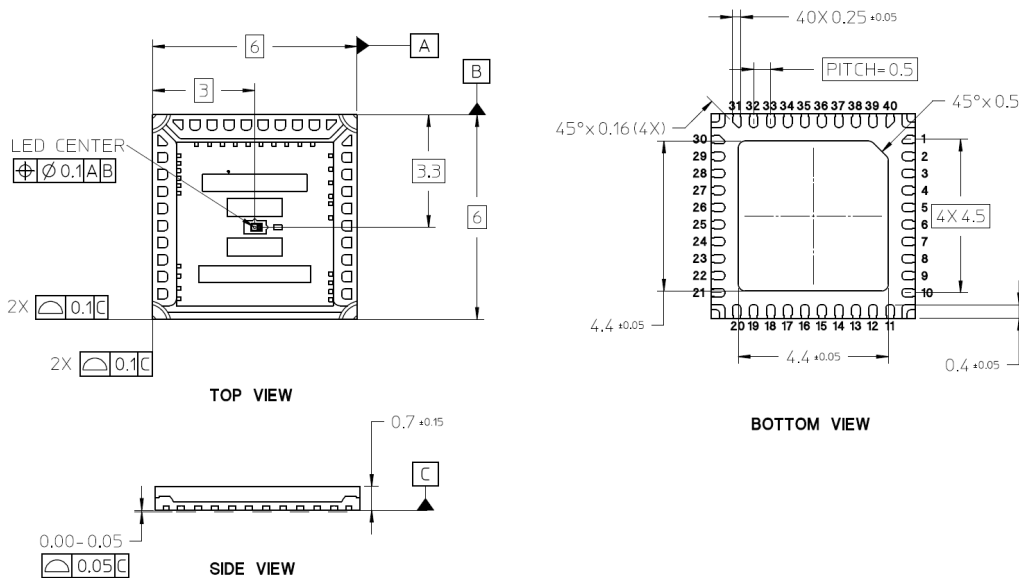

**NOTE:** All dimensions are in millimeters (mm).

Table 1: Pinout

Pin	Name	Function
1	Port_B3	The I/O protocol depends on Port_SEL[3:0] or internal register selection.
2	Port_B2	
3	Port_B1	
4	Port_B0	
5	VDDD	Digital power 3.3V/5V
6	DGND	Digital ground
7	Port_A3	The I/O protocol depends on Port_SEL[3:0] or internal register selection.
8	Port_A2	
9	Port_A1	
10	Port_A0	
11	No Connection	Open/no connection
12	No Connection	
13	No Connection	
14	No Connection	
15	No Connection	
16	No Connection	
17	No Connection	
18	No Connection	
19	No Connection	
20	No Connection	

Pin	Name	Function
21	Port_C0	The multi-turn I/O protocol depends on Port_SEL[3:0] or internal register selection.
22	Port_C1	
23	Port_C2	
24	Port_C3	
25	AGND	Analog ground
26	VDDA	Analog power 3.3V/5V
27	Port_D0	Incremental and analog output depends on Port_SEL[3:0] or internal register selection.
28	Port_D1	
29	Port_D2	
30	Port_D3	
31	nRESET	Power-up delay or ASIC reset pin
32	Port_SEL0	Protocol selection or output selection pin. Refer to the AR25DP series application note for selection details.
33	Port_SEL1	
34	Port_SEL2	
35	Port_SEL3	
36	Port_E0	I <sup>2</sup> C SDA external EEPROM
37	Port_E1	I <sup>2</sup> C SCL external EEPROM
38	VDDcap_1p8V	Buffer capacitor 1.8V
39	VDDcap_3p3V	Buffer capacitor 3.3V
40	External Oscillator	50-MHz external oscillator input

**NOTE:**

1. For more details on the PORT\_SEL[3:0] selection, refer to the AR25DP series application note.
2. VDDD and VDDA must be connected to the same voltage level of 3.3V or 5V.

## Package Marking

Figure 8: Product Marking Information

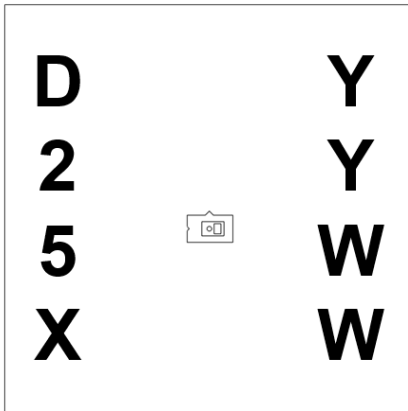

### MARKING CONFIGURATION

PART NUMBER	PROTOCOL	MARKING
AR25S	STANDARD	D25S
AR25B	BISS	D25B

YYWW: YEAR, WORK WEEK

## Encoder Mounting

Figure 9: Encoder Mounting Details

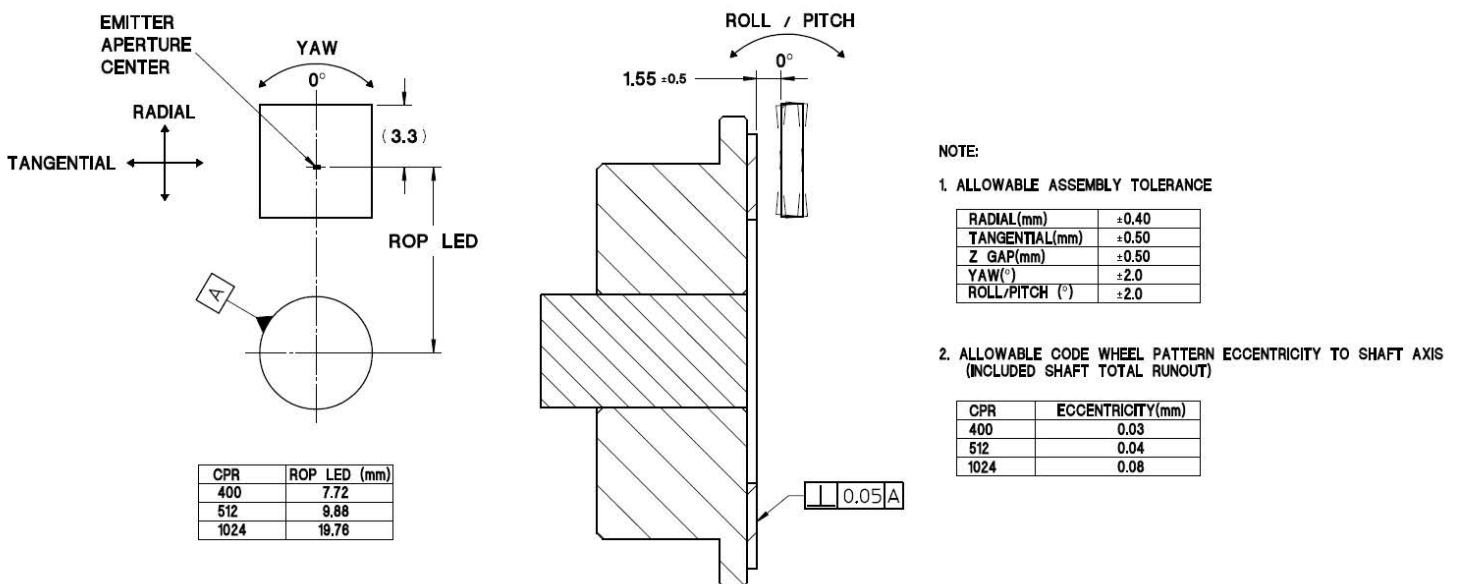

### NOTE:

1. The assembly of the encoder requires a clean room condition, Class 100K or better.
2. For optimal protection against external contamination, the encoder requires an enclosure rated IP50 higher.
3. For more mechanical design requirements, refer to the AR25DP series application note.
4. Contact Broadcom for nonstandard code-wheel designs.

## Code-Wheel Specifications

Table 2: Encoder Product Size Design Guide

Parameter	Code-Wheel Inner Diameter (Max.)	Code-Wheel Outer Diameter (Min.)	Product Outer Diameter (Min.)	Motor Shaft (Max.)	Unit
400 CPR	10	20	30	6	mm
512 CPR	15	25	35	12	mm
1024 CPR	35	45	55	30	mm

Table 3: Recommended Code-Wheel and Code-Strip Characteristics

Parameter	Symbol	Min.	Typical	Max.	Unit	Notes
Specular Reflectance	$R_f$	80%	—	—	—	Reflective area
		—	—	5%	V	Nonreflective area

**NOTE:** Characteristics are based on Broadcom-qualified code-wheel suppliers. Contact Broadcom for qualified reflective code-wheel suppliers.

Figure 10: Metal (Stainless Steel or Aluminum) Code-Wheel and Code-Strip Structure

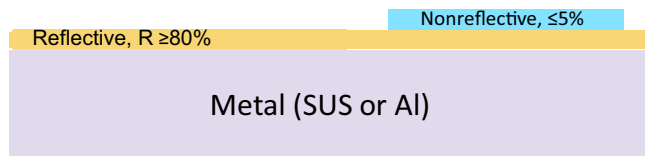



## Moisture Sensitivity Level

The AR25DP package is specified to a moisture sensitive level 3 (MSL 3). Take precautions when handling this moisture-sensitive product to ensure the reliability of the product.

- Storage before use:
  - An unopened moisture barrier bag (MBB) can be stored at  $<40^{\circ}\text{C}/90\% \text{ RH}$  for 12 months.
  - Open the MBB just prior to assembly.
- Control after opening the MBB:
  - The encoder that will be subjected to reflow solder must be mounted within 168 hours and kept in factory conditions of  $<30^{\circ}\text{C}/60\% \text{ RH}$ .
- Control for unfinished reels:
  - Store unused encoders in a sealed MBB with desiccant or a desiccator at  $<5\% \text{ RH}$ .
- Baking is required if any of the following conditions exist:
  - The humidity indicator card (HIC) is  $>10\%$  when read at  $23^{\circ}\text{C} \pm 5^{\circ}\text{C}$ .
  - The encoder's floor life has exceeded 168 hours.

The recommended baking condition is  $40^{\circ}\text{C} \pm 5^{\circ}\text{C}$  for 22 hours (tape and reel) or  $125^{\circ}\text{C} \pm 10^{\circ}\text{C}$  for 1 hour (loose units).

Figure 12: Recommended SMT Reflow Soldering Profile

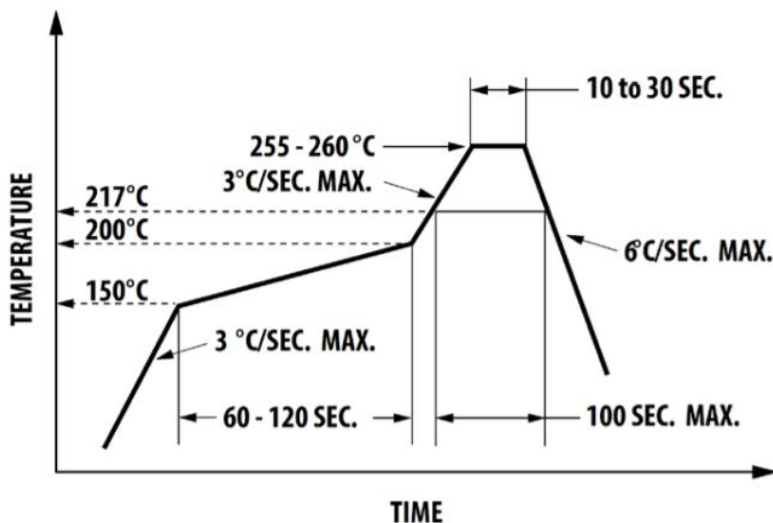

### NOTE:

1. Use the lead-free SMT reflow soldering profile per JEDEC standard J-STD-020D.
2. Use infrared reflow and no cleaning process to prevent contamination.

# Product Specifications

## Absolute Maximum Ratings

Table 4: Absolute Maximum Ratings

Parameter	Symbol	Value
Storage Temperature	$T_S$	-40°C to 125°C
Operating Temperature	$T_A$	-40°C to 125°C
Supply Voltage	$V_{DD}$	6.5V
ESD (HBM), JS-001-2014	—	±2 kV
Moisture Sensitive Level	MSL	3 (Maximum floor life = 168 hours)

### NOTE:

1. Proper operation of the encoder cannot be guaranteed if the maximum ratings are exceeded.
2. Take precautions to always keep the encoder ASIC clean. Assemble in a clean room condition, Class 100k or better.
3. Some particles might be present on the encoder ASIC surface. The presence of these particles can degrade the performance of the encoder.

**CAUTION!** Anti-static discharge precautions should be taken when handling the encoder to avoid damage and/or degradation induced by ESD.

Subjecting the product to stresses beyond those listed in this section can cause permanent damage to the devices. These are stress ratings only and do not imply that the devices will function beyond these ratings. Exposure to the extremes of these conditions for extended periods can affect product reliability.

## Electrical Specifications

Table 5: Recommended Operating Conditions

Parameter	Symbol	Min.	Typ.	Max.	Unit	Notes
DC Supply Voltage 5V	$V_{DD}$	+4.5	+5.0	+5.5	V	
DC Supply Voltage 3.3V	$V_{DD}$	+3.0	+3.3	+3.6	V	
Ripple of Supply Voltage	—	—	—	100	mVpp	100 kHz
Output Current per Channel	—	—	—	±5	mA	Single-ended digital output
Rise Time	$t_r$	—	30	—	ns	$C_L = 50$ pF
Fall Time	$t_f$	—	30	—	ns	$R_L = 1.2$ kΩ
Ambient Temperature	$T_{amb}$	—	+25	—	°C	
Operational Temperature	$T_{PCB}$	-40	+25	+125	°C	PCB (FR4-4 layers) temperature
Storage Temperature	$T_S$	-40	+25	+125	°C	
Humidity	RH	—	—	85	%	Temperature = 40°C
INC Operating Frequency	f	—	—	128	kHz	Velocity (RPM) × CPR/60
Encoder Shaft Speed	SRPM	—	—	15,000	RPM	With a 512-CPR code wheel
Radial Misalignment	—	-500	Nominal	+500	μm	
Tangential Misalignment	—	-400	Nominal	+400	μm	
Gap	—	-500	Nominal	+500	μm	
Temperature Sensor Accuracy	—	—	±3	—	°C	At 125°C

## DC Characteristics

**Table 6: DC Characteristics over Recommended Operating Range, Typical at 25°C**

Parameter	Symbol	Conditions	Min.	Typ.	Max.	Unit	Notes
V <sub>DD</sub> Supply Current	I <sub>DD</sub>	V <sub>DD</sub> = 3.3V	—	65	—	mA	
		V <sub>DD</sub> = 5.0V	—	65	—	mA	
Absolute Single-Turn Resolution	ST <sub>bits</sub>	—	15	—	25 <sup>a</sup>	Bit	
Incremental Resolution	—	—	1	—	2 <sup>n<sub>max</sub></sup>	CPR	n <sub>max</sub> = 20
Protocol I/O Drive Strength	I <sub>DIO</sub>	V <sub>DD</sub> = 3.3V/5V	5	20	40	mA	Differential driver
Differential Transceiver Hysteresis	V <sub>hys</sub>	V <sub>DD</sub> = 3.3V/5V	—	100	—	mV	220Ω termination
Differential Transceiver Opening	V <sub>open</sub>	V <sub>DD</sub> = 3.3V/5V	200	—	—	mV	
Differential Transceiver Voltage Peak-to-Peak	V <sub>pp</sub>	V <sub>DD</sub> = 3.3V/5V	—	2	—	V	
Output High Voltage	V <sub>OH</sub>	V <sub>DD</sub> = 3.3V	2.4	—	—	V	No load
Output Low Voltage	V <sub>OL</sub>		—	5	0.4	V	
Input High Voltage	V <sub>IH</sub>		—	—	2	V	
Input Low Voltage	V <sub>IL</sub>		0.8	—	—	V	
Output High Voltage	V <sub>OH</sub>	V <sub>DD</sub> = 5.0V	4.4	—	—	V	No load
Output Low Voltage	V <sub>OL</sub>		—	5	0.5	V	
Input High Voltage	V <sub>IH</sub>		—	—	3.5	V	
Input Low Voltage	V <sub>IL</sub>		1.5	—	—	V	

a. Maximum number of bits able to be set in the AR25DP.

## Encoder Characteristics

**Table 7: Incremental Encoder Characteristics over Recommended Operating Condition, at 25°C with Interpolation Factor of 32X<sup>a</sup>**

ABI Parameter	Symbol	Min.	Typ.	Max. <sup>b</sup>	Unit
Cycle Error	$\Delta C$	—	—	45	°e
State Error	$\Delta S$	—	—	45	°e
Index Pulse Width	Po	—	90, 180, 270, 360	—	°e

a. Base CPR = 512 CPR, and the incremental output =  $32 \times 512 = 16,384$  CPR.

b. Maximum values represent the encoder performance across the range of recommended mounting tolerances.

**Table 8: Commutation Characteristic over Recommended Operating Condition, at 25°C with 32 Pole Pairs**

Commutation (UVW) Parameter	Symbol	Min.	Typ.	Max. <sup>a</sup>	Unit
Commutation Accuracy (Middle of channel I to channel U)	$\Delta I$	-0.1	—	+0.1	°mechanical
Commutation Accuracy (Channel U, V, and W)	$\Delta UVW$	-0.1	—	+0.1	°mechanical

a. Maximum values represent the encoder performance across the range of recommended mounting tolerances.

**Table 9: Rotary Encoder Raw Accuracy Characteristics over Recommended Operating Condition, at 25°C**

Parameter	Symbol	Min.	Typ. <sup>a</sup>	Max.	Unit
Raw Accuracy (AR25DP)	—	—	$\pm 350$	—	arcsecond
Accuracy_AutoCal (Speed) <sup>b</sup>	—	—	$\pm 120$	—	arcsecond
Accuracy_ManualCal (Reference Encoder) <sup>c</sup>	—	—	$\pm 30$	—	arcsecond

a. Typical values represent encoder performance with shaft  $T_{IR} < 10 \mu\text{m}$ ,  $\phi 5.991 \text{ mm}$  to  $5.996 \text{ mm}$ ; code-wheel hub ID =  $\phi 6.000 \text{ mm}$  to  $6.008 \text{ mm}$ .

b. Typical values represent calibration with a motor speed ripple of  $< 0.1\%$ .

c. Typical values represent the accuracy and repeatability when calibrated with a reference encoder having  $10\times$  higher accuracy than the AR25DP (reference encoder accuracy  $\leq 3$  arcseconds).

## Analog Signal Characteristics

Figure 13: Analog Waveform

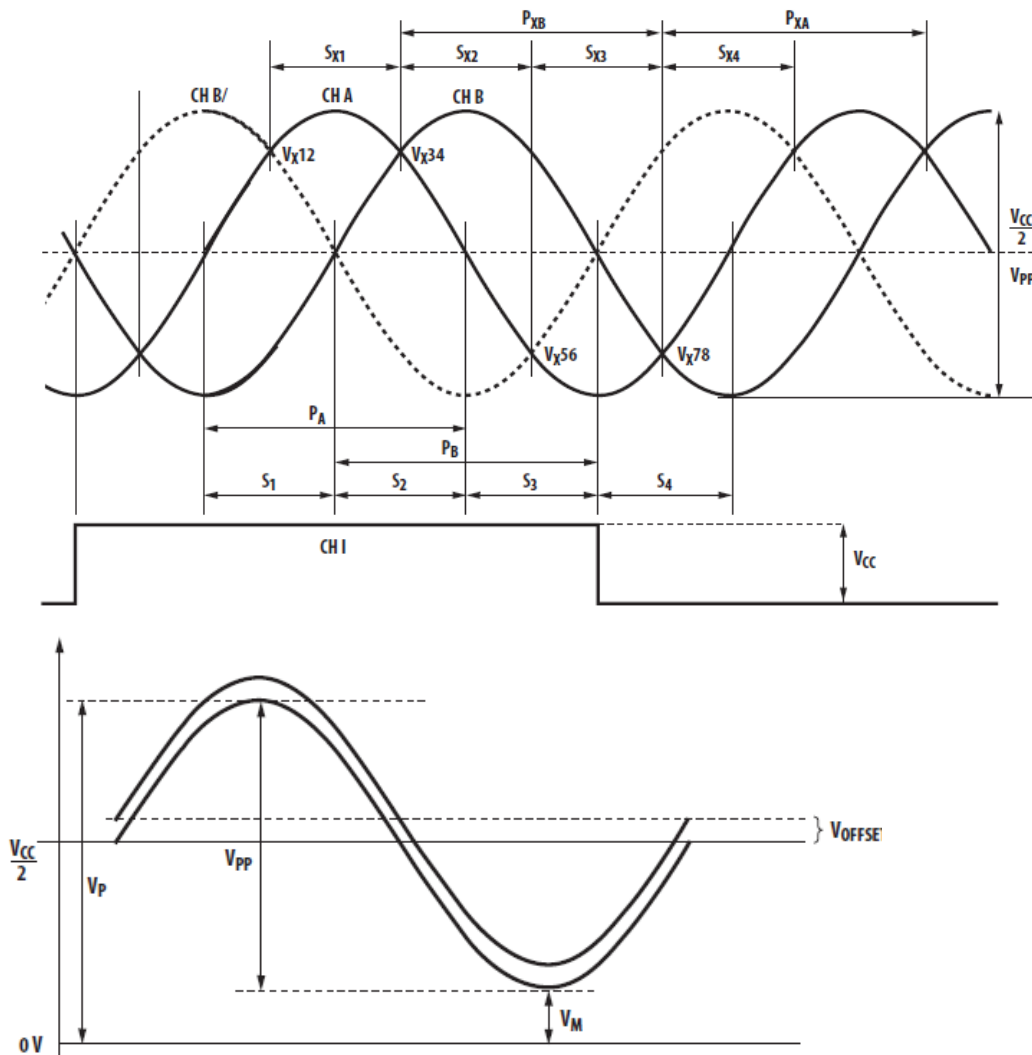

Table 10: Test Parameter Definitions

Parameter	Symbol	Description
Analog Peak-to-Peak	$V_{pp}$	The peak-to-peak signal magnitude in V of the analog signal.
Analog Offset	$V_{OFFSET}$	The offset in mV from the midpoint of the analog peak-to-peak signal to the zero-voltage point.
Analog Peak/Valley Voltage	$V_{PA}, V_{PB}, V_{MA}, V_{MB}$	The value in V of the peak/valley of the analog signal, which is a one-sided reading.
Analog Peak-to-Peak Voltage	$V_{PPA}, V_{PPB}$	The absolute difference between $V_P$ and $V_M$ of channel A or B.
Analog Crosspoint Voltage	$V_{X12}, V_{X34}, V_{X56}, V_{X78}$	The intersections in V of the channel A analog waveform with that of either channel B or its component.
Analog Offset Voltage	$V_{OFFSETA}, V_{OFFSETB}$	The offset in mV from the midpoint of the analog peak-to-peak signal to $V_{pp}/2$ .

**Table 11: Analog Signal Characteristics**

Parameter	Symbol	Min.	Typical	Max.	Unit
Peak-to-Peak Voltage (Average)	$V_{PPA}, V_{PPB}$	0.9	1	1.1	V
Analog Offset Voltage	$V_{OFFSETA}, V_{OFFSETB}$	0.45 $V_{CC}$	0.5 $V_{CC}$	0.55 $V_{CC}$	V
Voltage Reference (Midpoint of Signal $V_{pp}$ )	$V_{ref}$	—	$V_{CC}/2$	—	V
Index Pulse Width	I	—	360/270/180/90	—	°e
State Width Error	$\Delta S$	—	$\pm 10$	—	°e
Pulse Width Error	$\Delta P$	—	$\pm 10$	—	°e
State X Width Error	$\Delta S_x$	—	$\pm 5$	—	°e
Pulse X Width Error	$\Delta P_x$	—	$\pm 5$	—	°e

**NOTE:**

1. Typical values represent the average value of encoder performance in our factory-based setup conditions.
2. The optimal performance of the encoder depends on the motor/system setup conditions of the individual customer.

# Tape and Reel Packing Information

Figure 14: AR25DP Carrier Tape Dimensions

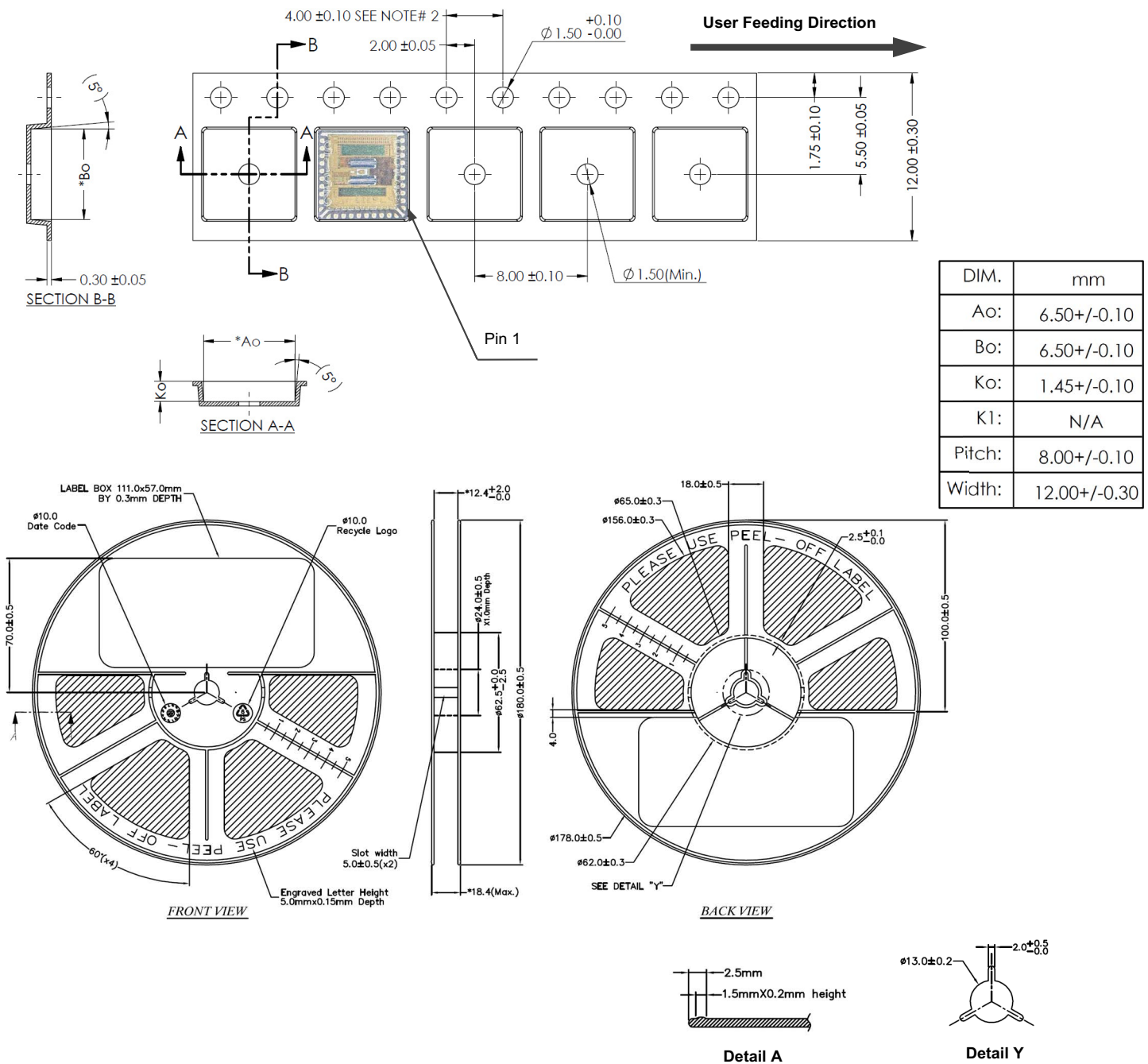

**NOTE:** All dimensions are in millimeters (mm).

**Table 12: Encoder Packing Information**

Device	Tape and Reel Quantity	Inner Box: 248 mm × 230 mm × 26 mm	Option 1: Outer Box 340 mm × 275 mm × 75 mm		Option 2: Outer Carton Box 340 mm × 270 mm × 250 mm	
		Weight	Weight	Note	Weight	Note
AR25DP-Ax01-TR01	100	215g	703g	Maximum 200 pieces per box	2.49 kg	Maximum 10,000 pieces per box
AR25DP-Ax01-TR02	1000	310g	891g	Maximum 2000 pieces per box	3.43 kg	Maximum 100,000 pieces per box

**Figure 15: Encoder Tape Packing, Inner Box, and Outer Carton Box Information**

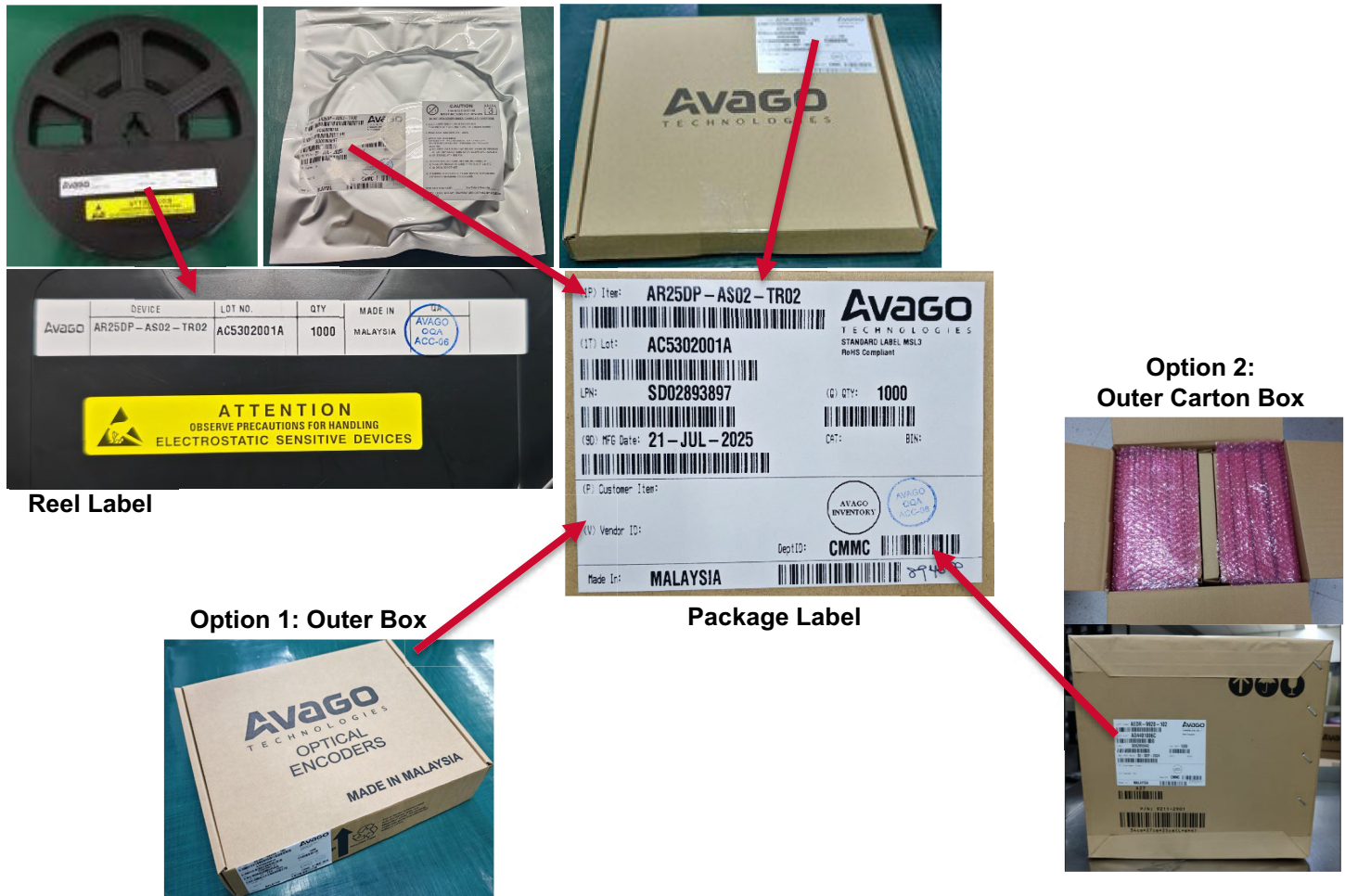

# Evaluation Board and Accessories

Figure 16: AR25-E01 Calibration Kit and Software User Interface

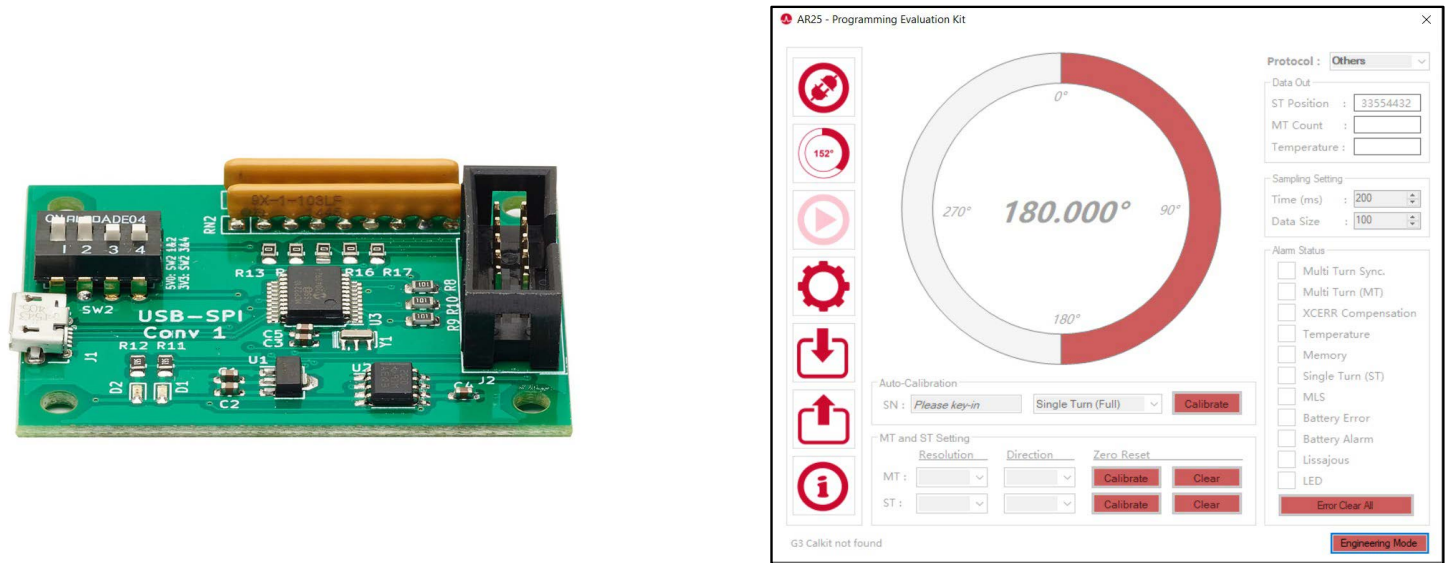
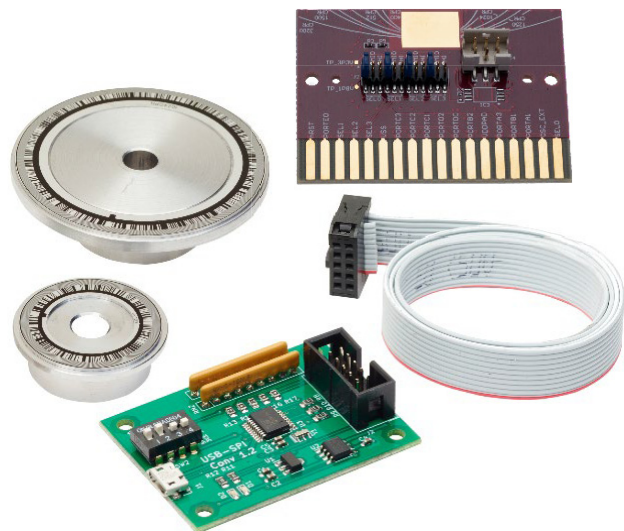

Figure 17: AR25DP-EVB-AxxT Encoder Evaluation Board with Metal Code Wheel



Figure 18: AR25DP-PRGEVB-A12T with Programming Kit, Evaluation Board, and Metal Code Wheel



## Ordering Information

A R 2 5 D P - A X 0 Y - T R 0 Z

Code	Description	Option	
X	Communication Protocol	B	BiSS-C (10 MHz)
		S	SSI (10 MHz) SPI 4-wire (10 MHz) ESL (10 Mb/s) RS-485 (2.5/5/10 Mb/s)
Y, Z	Tape and Reel Quantity	1	100 pieces
		2	1000 pieces

Part Number	Description
<b>Encoder ASIC Package</b>	
AR25DP-AS02-TR02	25-bit absolute ASIC up to 60 mm, SSI/SPI/485/ESL, tape and reel, 1000 pieces
AR25DP-AS01-TR01	25-bit absolute ASIC up to 60 mm, SSI/SPI/485/ESL, tape and reel, 100 pieces
AR25DP-AB02-TR02	25-bit absolute ASIC up to 60 mm, BiSS-C, tape and reel, 1000 pieces
AR25DP-AB01-TR01	25-bit absolute ASIC up to 60 mm, BiSS-C, tape and reel, 100 pieces
<b>Evaluation PCBA, Through-Hole Rotary Code Wheel</b>	
AR25DP-EVB-A12T	AR25DP PCBA with 512-CPR code wheel, 6-mm through-hollow, all protocols
AR25DP-EVB-A13T	AR25DP PCBA with 512-CPR code wheel, 8-mm through-hollow, all protocols
AR25DP-EVB-A18T	AR25DP PCBA with 512-CPR code wheel, 12-mm through-hollow, all protocols
AR25DP-EVB-A20T	AR25DP PCBA with 1024-CPR code wheel, 20-mm through-hollow, all protocols
AR25DP-EVB-A30T	AR25DP PCBA with 1024-CPR code wheel, 30-mm through-hollow, all protocols
<b>Evaluation Set with Programming Kit, PCBA, Through-Hole Rotary Code Wheel</b>	
AR25DP-PRGEVB-A12T	AR25DP evaluation set with AR25-E01 SPI-4W interface, electronic calibration kit, evaluation PCBA, 6-mm hub, 512-CPR code wheel
AR25DP-PRGEVB-A13T	AR25DP evaluation set with AR25-E01 SPI-4W interface, electronic calibration kit, evaluation PCBA, 8-mm hub, 512-CPR code wheel
AR25DP-PRGEVB-A18T	AR25DP evaluation set with AR25-E01 SPI-4W interface, electronic calibration kit, evaluation PCBA, 12-mm hub, 512-CPR code wheel
AR25DP-PRGEVB-A20T	AR25DP evaluation set with AR25-E01 SPI-4W interface, electronic calibration kit, evaluation PCBA, 20-mm hub, 1024-CPR code wheel
AR25DP-PRGEVB-A30T	AR25DP evaluation set with AR25-E01 SPI-4W interface, electronic calibration kit, evaluation PCBA, 30-mm hub, 1024-CPR code wheel
<b>Through-Hole Rotary Code Wheel</b>	
AR25-A12T	512-CPR code wheel, through-hollow, 6-mm inner diameter
AR25-A13T	512-CPR code wheel, through-hollow, 8-mm inner diameter
AR25-A18T	512-CPR code wheel, through-hollow, 12-mm inner diameter
AR25-A15T	1024-CPR code wheel, through-hollow, 15-mm inner diameter
AR25-A20T	1024-CPR code wheel, through-hollow, 20-mm inner diameter
AR25-A30T	1024-CPR code wheel, through-hollow, 30-mm inner diameter

Part Number	Description
<b>Programming Kit</b>	
AR25-E01	AR25/AR25DP reference design programming and calibration kit and software interface (SPI 4-wire)
<b>Programming and Accuracy Calibration Station</b>	
AR25-AC25	Accuracy calibration station for AR18/AR25/AR35/AR49/AR25DP series rotary reflective encoder Contents: Mechanical setup including servo motor control, high-accuracy reference encoder, programming kits, associated cable assemblies (for PC interface, motor handler communication, DUT encoder connection), and the associated GUI programming software

Copyright © 2025–2026 Broadcom. All Rights Reserved. The term “Broadcom” refers to Broadcom Inc. and/or its subsidiaries. For more information, go to [www.broadcom.com](http://www.broadcom.com). All trademarks, trade names, service marks, and logos referenced herein belong to their respective companies.

Broadcom reserves the right to make changes without further notice to any products or data herein to improve reliability, function, or design. Information furnished by Broadcom is believed to be accurate and reliable. However, Broadcom does not assume any liability arising out of the application or use of this information, nor the application or use of any product or circuit described herein, neither does it convey any license under its patent rights nor the rights of others.