

## APDS-9250

### Digital RGB, IR, and Ambient Light Sensor

#### Description

The Broadcom<sup>®</sup> APDS-9250 device uses four individual channels of red, green, blue, and IR (RGB+IR) in a specially designed matrix arrangement. This allows the device to have optimal angular response and accurate RGB spectral response with high lux accuracy over various light sources. The APDS-9250 supports the I<sup>2</sup>C interface and has a programmable interrupt controller that frees up micro-controller resources.

The device detects light intensity under a variety of lighting conditions and through a variety of attenuation materials, including dark glass. The APDS-9250 could be configured as an ambient light sensor and a RGB+IR sensor. The color-sensing feature is useful in applications, such as LED RGB backlight control, solid-state lighting, reflected LED color sampler, or fluorescent light color temperature detection. The integrated IR blocking filter makes this device an excellent ambient light sensor and color temperature monitor sensor together with the temperature compensation that allows output to have less variation over the temperature.

#### Ordering Information

Part Number	Packaging	Quantity
APDS-9250	Tape and Reel	5000 per reel

#### Features

- RGB and ambient light sensing (RGB and ALS)
  - Accuracy of correlated color temperature (CCT)
  - Individual channels for red, green, blue, and infrared
  - Approximates human eye response with green channel
  - Red, green, blue, infrared, and ALS sensing
  - High sensitivity in low lux condition – ideally suited for operation behind dark glass
  - Wide dynamic range: 18,000,000: 1
  - Up to 20-bit resolution
- Power management
  - Low active current
  - Low standby current
- I<sup>2</sup>C-bus fast mode compatible interface
  - Up to 400 kHz (I<sup>2</sup>C fast-mode)
  - Dedicated interrupt pin
- Small package L 2.0 mm x W 2.0 mm x H 0.65 mm

#### Applications

- OLED display control
- RGB LED backlight control
- Ambient light color temperature sensing

# Functional Block Diagram

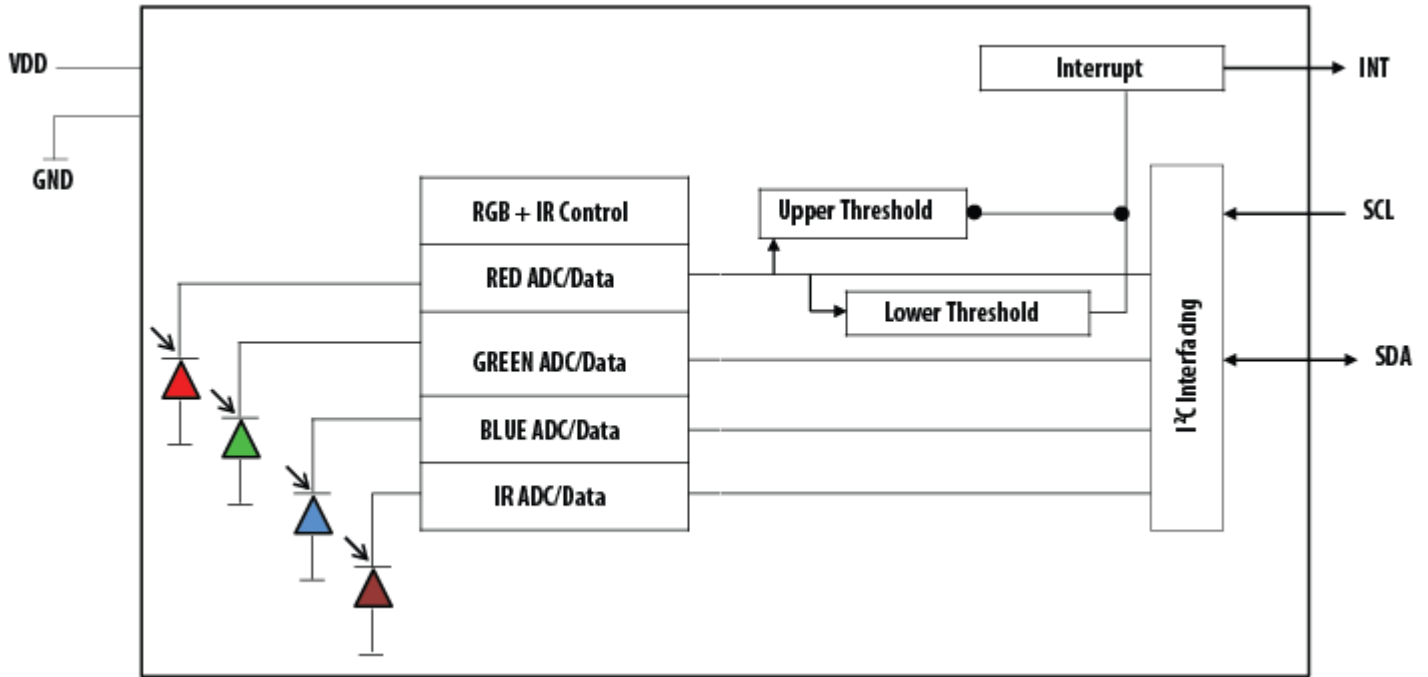

## Description

The APDS-9250 device contains multiple photodiodes for light sensor (R, G, B, IR channel) that are designed in a matrix placement to achieve optimal angular response at the fall of incident light angle.

The device provides on-chip multiple diodes, ADCs, state machine, nonvolatile memory, and an I<sup>2</sup>C interface.

Integration of all color sensing channels occurs simultaneously. Upon completion of the conversion cycle, the conversion result is transferred to the corresponding data registers. Communication with the device is accomplished through a fast (up to 400 kHz), two-wire I<sup>2</sup>C serial bus for easy connection to a microcontroller or embedded controller.

The APDS-9250 provides a separate pin for interrupts. When interrupts are enabled and a preset value is exceeded, the interrupt pin is asserted and remains asserted until cleared by the controlling firmware. The interrupt feature simplifies and improves system efficiency by eliminating the need to poll a sensor for a light intensity. An interrupt is generated after completion of new conversion of the light sensor channels where the light sensor interrupt

source can work on any of the red, green, blue, or IR channels. Additionally, a programmable interrupt persistence feature allows the user to determine how many consecutive exceeded thresholds are necessary to trigger an interrupt.

## I/O Pins Configuration

Pin	Name	Type	Description
1	SCL	I	I <sup>2</sup> C Serial Clock Input Terminal – Clock Signal for I <sup>2</sup> C Serial Data
2	SDA	I/O	Serial Data I/O for I <sup>2</sup> C
3	VDD	Supply	Power Supply Voltage
4	INT	O	Interrupt – Open Drain
5	NC		No Connect
6	GND	Ground	Power Supply Ground. All voltages are referenced to GND.

## Absolute Maximum Ratings

Over operating free-air temperature range (see Note).

Parameter	Symbol	Min.	Max.	Units	Conditions
Power Supply Voltage <sup>a</sup>	$V_{DD}$	—	3.8	V	
Digital Voltage Range		-0.5	3.8	V	
Storage Temperature Range	$T_{stg}$	-40	85	°C	

a. All voltages are with respect to GND.

**NOTE:** Stresses beyond those listed under [Absolute Maximum Ratings](#) may cause permanent damage to the device. These are stress ratings only and functional operation of the device at these or any other conditions beyond those indicated under [Recommended Operating Conditions](#) is not implied. Exposure to absolute-maximum-rated conditions for extended periods may affect device reliability.

## Recommended Operating Conditions

Parameter	Symbol	Min.	Typ.	Max.	Units
Operating Ambient Temperature	$T_A$	-40	—	85	°C
Supply Voltage	$V_{DD}$	1.7	—	3.6	V
Supply Voltage Accuracy, $V_{DD}$ total error including transients		-3	—	3	%

## Operating Characteristics

$V_{DD} = 2.8V$ ,  $T_A = 25^\circ C$  (unless otherwise noted).

Parameter	Symbol	Min.	Typ.	Max.	Units	Test Conditions
Active Mode Current	$I_{CS}$	—	130	—	$\mu A$	$V_{DD} = 2.8V$ , Gain Mode 3
Standby Current	$I_{STBY}$	—	1	2	$\mu A$	In Standby Mode. No active I <sup>2</sup> C communication
SCL, SDA Input High Voltage	$V_{IH}$	1.5	—	$V_{DD}$	V	
SCL, SDA Input Low Voltage	$V_{IL}$	0	—	0.4	V	
$V_{OL}$ INT, Output Low Voltage	$V_{OL}$	0	—	0.4	V	
$I_{LEAK}$ Leakage Current, SDA, SCL, INT Pins	$I_{LEAK}$	-5	—	5	$\mu A$	

## Optical Characteristics

$V_{DD} = 2.8V$ ,  $T_A = 25^\circ C$  (unless otherwise noted).

Parameter	Test Condition	RED Channel		Green Channel		Blue Channel		IR Channel		Unit
		Min.	Max.	Min.	Max.	Min.	Max.	Min.	Max.	
Irradiance Response	$\lambda = 465^a$	0	5	6	20	80	120	0	4	% <sup>b</sup>
	$\lambda = 525^c$	3	10	80	120	10	30	0	3	
	$\lambda = 625^d$	80	120	18	37	0	3	0	3	
	$\lambda = 850^e$	0	3	0	3	0	3	80	120	

- The 465 nm input irradiance is supplied by an InGaN light-emitting diode with the following characteristics: dominant wavelength  $\lambda_D = 465$  nm, spectral halfwidth  $\lambda_{1/2} = 22$  nm.
- The percentage shown represents the ratio of the respective red, green, or blue channel value to the IR channel value.
- The 525 nm input irradiance is supplied by an InGaN light-emitting diode with the following characteristics: dominant wavelength  $\lambda_D = 525$  nm, spectral halfwidth  $\lambda_{1/2} = 35$  nm.
- The 625 nm input irradiance is supplied by a AlInGaP light-emitting diode with the following characteristics: dominant wavelength  $\lambda_D = 625$  nm, spectral halfwidth  $\lambda_{1/2} = 15$  nm.
- The 850 nm input irradiance is supplied by a AlInGaP light-emitting diode with the following characteristics: dominant wavelength  $\lambda_D = 850$  nm, spectral halfwidth  $\lambda_{1/2} = 40$  nm.

## RGB Characteristics

$V_{DD} = 2.8V$ ,  $T_A = 25^\circ C$  (unless otherwise noted).

Parameter	Min.	Typ.	Max.	Units	Test Conditions
Dark Count	0	—	3	counts	
ADC Integration Time	2.97	3.125	3.28	ms	
Full Scale ADC Counts Per Step	—	8192	—	counts	13 bit
Full Scale ADC Count Value	—	—	262,143	counts	18 bit, 100 ms, G = 1x

## ALS Characteristics

$V_{DD} = 2.8V$ ,  $T_A = 25^\circ C$  (unless otherwise noted).

Parameter	Symbol	Min.	Typ.	Max.	Units	Test Conditions
Peak Wavelength	$\lambda_p$	—	550	—	nm	
Min. Integration Time	$T_{intmin1}$	—	3.125	—	ms	
	$T_{intmin2}$	—	50	—	ms	With 50 Hz/60 Hz rejection
Max. Integration Time	$T_{intmax}$	—	400	—	ms	With 50 Hz/60 Hz rejection
Output Resolution	$RES_{ALS}$	13	18	20	bit	Programmable
ADC Count Value		—	1000	—	counts	$\lambda = 530$ nm, 50 ms, Gain=3x, $E_e = 62 \mu W/cm^2$

Figure 1: Normalized ALS PD Angular Response

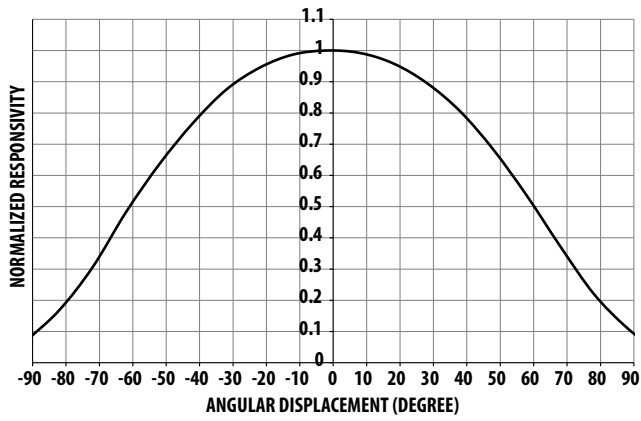

Figure 2: Normalized PD Spectral Response

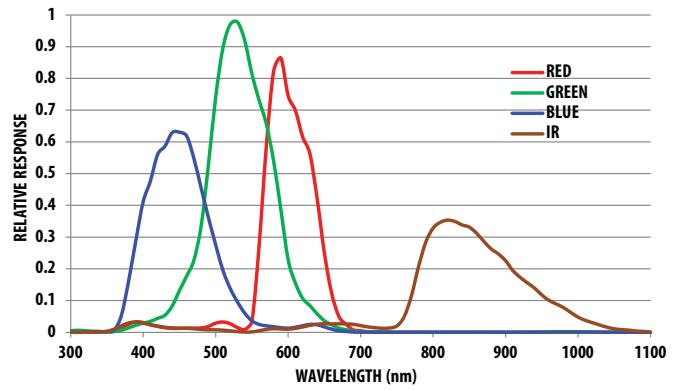

Figure 3: ALS Sensor LUX vs. Meter LUX Using White Light

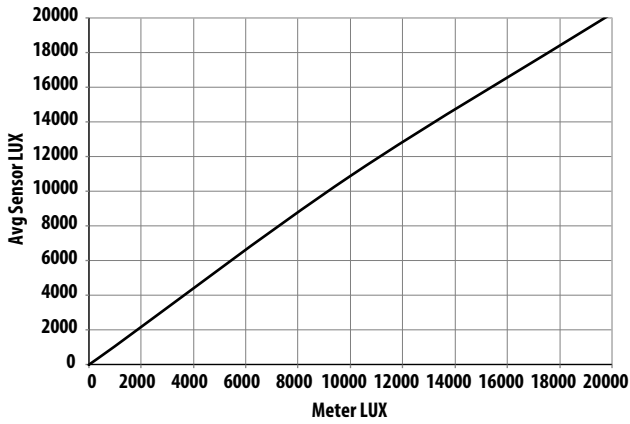

Figure 4: ALS Sensor LUX vs. Meter LUX Using White Light

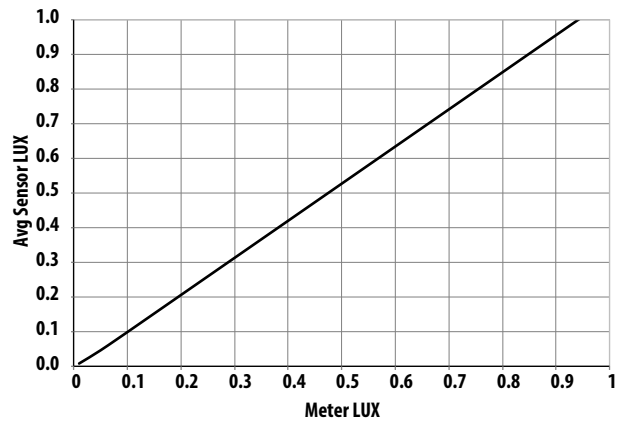

Figure 5: ALS Sensor LUX vs. Meter LUX Using Incandescent Light

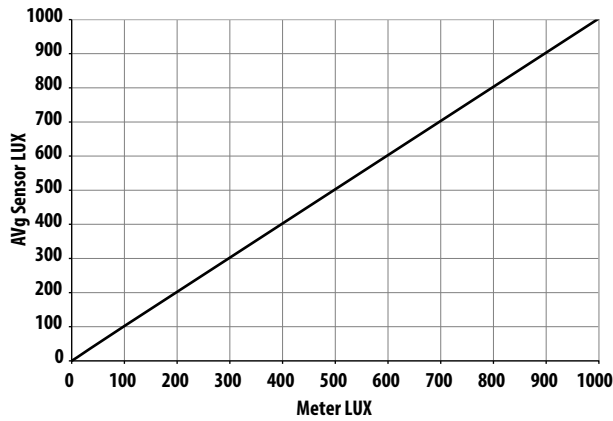

Figure 6: Normalized IDD vs. VDD

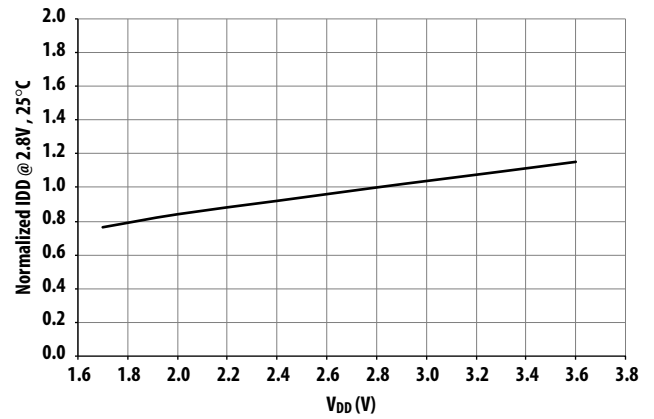

Figure 7: Normalized IDD vs. Temperature

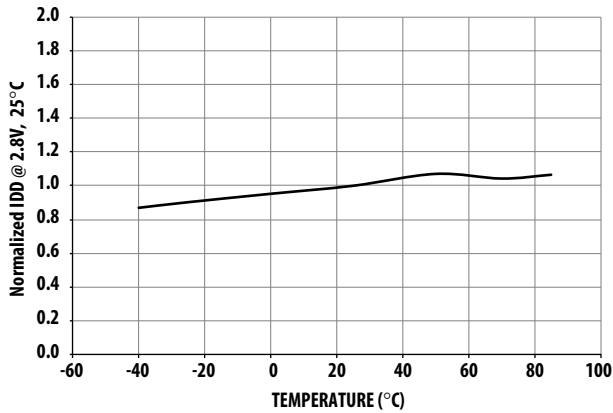
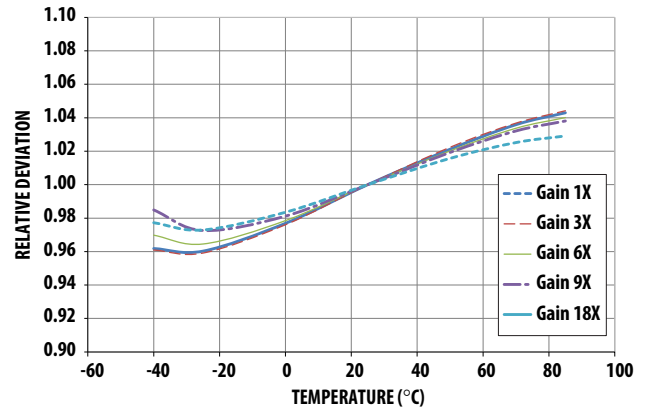

Figure 8: ALS vs. Temperature @ 1000 LUX (White LED)



# Principles of Operation for Light Sensor

## System State Machine

### Start Up after Power-On or Software Reset

The main state machine is set to "Start State" during power-on or software reset. As soon as the reset is released, the internal oscillator starts. The programmed I<sup>2</sup>C address and the trim values are read from the internal nonvolatile memory (NVM) trimming data block. The device enters Standby Mode as soon as the Idle State is reached.

**NOTE:** As long as the I<sup>2</sup>C address has not yet been read, the device will respond with NACK to any I<sup>2</sup>C command and ignore any request to avoid responding to a wrong I<sup>2</sup>C address.

### Standby Mode

Standby Mode is the default mode after power-up. In this state, the oscillator, all internal support blocks, and the ADCs are switched off but I<sup>2</sup>C communication is fully supported.

Figure 9: State Diagram

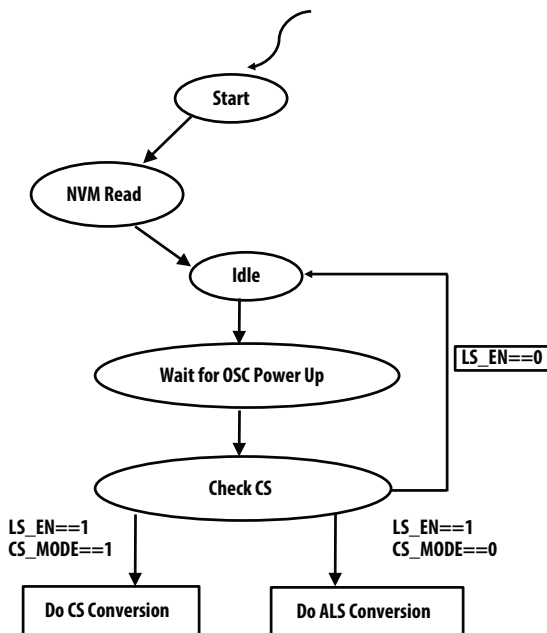

## Light Sensor Operation

Light Sensor (LS) measurements can be activated by setting the LS\_EN bit to 1 in the MAIN\_CTRL register.

In Light Sensor mode, the user can select to activate either ALS or CS operation mode. ALS mode is activated by setting CS\_Mode bit to 0 while CS mode is activated by CS\_Mode bit set to 1 in the MAIN\_CTRL register.

As soon as Light Sensor become activated through I<sup>2</sup>C command, the internal support blocks are powered on. Once the voltages and currents are settled (typically after 5 ms), the state machine checks for trigger events from a measurement scheduler to start the LS conversions according to the selected measurement repeat rates.

When LS\_EN is changed back to 0, a conversion running on the respective sensor will be completed and the relevant ADCs and support blocks will move to standby mode thereafter.

## Light Sensor Interrupt

The LS interrupt is enabled by LS\_INT\_EN=1. It can function as either threshold triggered (LS\_VAR\_MODE=0) or variance triggered (LS\_VAR\_MODE=1). The LS interrupt source generator can work on any of the four LS channels (R, G, B, IR). The LS interrupt source is selected by the LS\_INT\_SEL bits in the INT\_CFG register.

The Light Sensor threshold interrupt is enabled with LS\_INT\_EN = 1 and LS\_VAR\_MODE = 0. It is set when the data of the selected LS\_DATA input register (LS\_RED, LS\_GREEN, LS\_BLUE, LS\_IR) is above the upper or below the lower threshold for a specified number of consecutive measurements.

The Light Sensor variance interrupt is enabled with LS\_INT\_EN = 1 and LS\_VAR\_MODE = 1. It is set when the absolute value of the difference between the previous and current LS\_DATA data value is above the decoded LS variance threshold for a specified number of consecutive measurements.

## I<sup>2</sup>C Protocol

Interface and control of the APDS-9250 is accomplished through an I<sup>2</sup>C serial compatible interface (standard or fast mode) to a set of registers that provide access to device control functions and output data. The device supports a single slave address of 0x52 hex using 7-bit addressing protocol. (Contact the factory for other addressing options.)

## I<sup>2</sup>C Register Read

The registers can be read individually or in block read mode. When two or more bytes are read in block read mode, reserved register addresses are skipped and the next valid address is referenced. If the last valid address has been reached, but the master continues with the block read, the address counter in the device will not roll over and the device returns 00HEX for every subsequent byte read.

The block read operation is the only way to ensure correct data read out of multi-byte registers and to avoid splitting of results with HIGH and LOW bytes originating from different conversions. During block read access on LS and PS result registers, the result update is blocked.

If a read access is started on an address belonging to a non-readable register, the device will return NACK until the I<sup>2</sup>C operation is ended.

Read operations must follow the timing diagram shown in [Figure 10](#).

**Figure 10: I<sup>2</sup>C Register Read Timing Diagram**

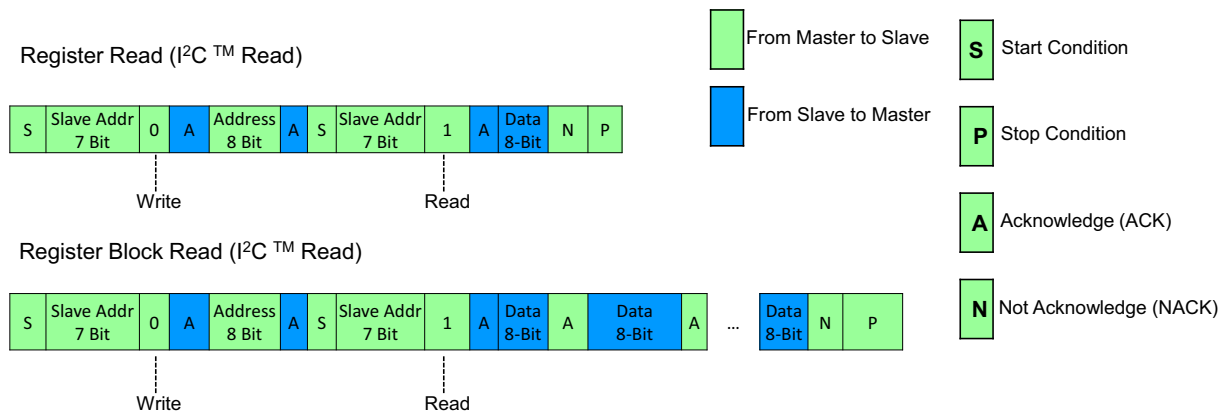

## I<sup>2</sup>C Register Write

The device registers can be written to individually or in block write mode. When two or more bytes are written in block write mode, reserved registers and read-only registers are skipped. The transmitted data is automatically applied to the next writable register. If a register includes read (R) and read/write (RW) bits, the register is not skipped. Data written to read-only bits are ignored.

If the last valid address of the device address range is reached but the master attempts to continue the block write operation, the address counter of the device will not roll over. The device will return NACK for every following byte sent by the master until the I<sup>2</sup>C operation is ended.

If a write access is started on an address belonging to a non-writeable register, the device will return NACK until the I<sup>2</sup>C™ operation is ended.

Write operations must follow the timing diagram shown in [Figure 11](#).



**Figure 11: I<sup>2</sup>C Register Write Timing Diagram**

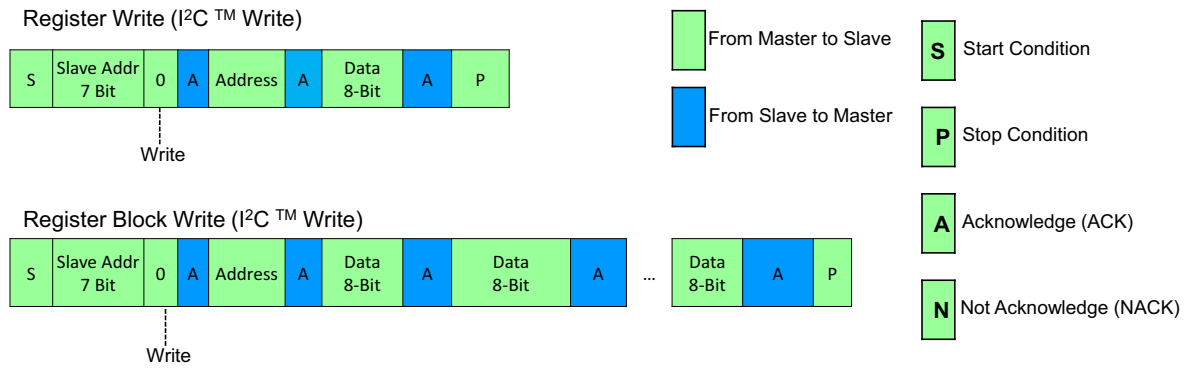

## Register Set

The APDS-9250 is controlled and monitored by data registers and a command register accessed through the serial interface. These registers provide for a variety of control functions and can be read to determine results of the ADC conversions.

Address	Type	Name	Description	Reset Value
00HEX	RW	MAIN_CTRL	LS operation mode control, SW reset	00HEX
04HEX	RW	LS_MEAS_RATE	LS measurement rate and resolution in active mode	22HEX
05HEX	RW	LS_GAIN	LS analog gain range	01HEX
06HEX	R	PART_ID	Part number ID and revision ID	B5HEX
07HEX	R	MAIN_STATUS	Power-on status, interrupt status, data status	20HEX
0AHEX	R	LS_DATA_IR_0	IR ADC measurement data - LSB	00HEX
0BHEX	R	LS_DATA_IR_1	IR ADC measurement data	00HEX
0CHEX	R	LS_DATA_IR_2	IR ADC measurement data - MSB	00HEX
0DHEX	R	LS_DATA_GREEN_0	Green ADC measurement data - LSB	00HEX
0EHEX	R	LS_DATA_GREEN_1	Green ADC measurement data	00HEX
0FHEX	R	LS_DATA_GREEN_2	Green ADC measurement data - MSB	00HEX
10HEX	R	LS_DATA_BLUE_0	Blue ADC measurement data - LSB	00HEX
11HEX	R	LS_DATA_BLUE_1	Blue ADC measurement data	00HEX
12HEX	R	LS_DATA_BLUE_2	Blue ADC measurement data - MSB	00HEX
13HEX	R	LS_DATA_RED_0	Red ADC measurement data - LSB	00HEX
14HEX	R	LS_DATA_RED_1	Red ADC measurement data	00HEX
15HEX	R	LS_DATA_RED_2	Red ADC measurement data - MSB	00HEX
19HEX	RW	INT_CFG	Interrupt configuration	10HEX
1AHEX	RW	INT_PERSISTENCE	Interrupt persist setting	00HEX
21HEX	RW	LS_THRES_UP_0	LS interrupt upper threshold, LSB	FFHEX
22HEX	RW	LS_THRES_UP_1	LS interrupt upper threshold	FFHEX
23HEX	RW	LS_THRES_UP_2	LS interrupt upper threshold, MSB	0FHEX
24HEX	RW	LS_THRES_LOW_0	LS interrupt lower threshold, LSB	00HEX
25HEX	RW	LS_THRES_LOW_1	LS interrupt lower threshold	00HEX
26HEX	RW	LS_THRES_LOW_2	LS interrupt lower threshold, MSB	00HEX
27HEX	RW	LS_THRES_VAR	LS interrupt variance threshold	00HEX

## MAIN\_CTRL

Default Value: 00HEX

<b>7</b>	<b>6</b>	<b>5</b>	<b>4</b>	<b>3</b>	<b>2</b>	<b>1</b>	<b>0</b>	
0	0	0	SW Reset	0	CS_Mode	LS_EN	0	0x00

Field	Bit	Description
SW Reset	4	1: Reset will be triggered
CS_Mode	2	0: ALS, IR and compensation channels activated 1: All RGB+IR + compensation channels activated
LS_EN	1	0: Light sensor standby 1: Light sensor active

## LS\_MEAS\_RATE

Default Value: 22HEX

<b>7</b>	<b>6</b>	<b>5</b>	<b>4</b>	<b>3</b>	<b>2</b>	<b>1</b>	<b>0</b>	
0	LS Resolution/Bit Width			0	LS Measurement Rate			0x04

Field	Bit	Description
LS Resolution/Bit Width	6:4	000: 20 bit – 400 ms 001: 19 bit – 200 ms 010: 18 bit – 100 ms ( <b>default</b> ) 011: 17 bit – 50 ms 100: 16 bit – 25 ms 101: 13 bit – 3.125 ms 110: Reserved 111: Reserved
LS Measurement Rate	2:0	000: 25 ms 001: 50 ms 010: 100 ms ( <b>default</b> ) 011: 200 ms 100: 500 ms 101: 1000 ms 110: 2000 ms 111: 2000 ms

When the measurement repeat rate is programmed to be faster than possible for the programmed ADC measurement time, the repeat rate will be lower than programmed (maximum speed).

Writing to this register stops the ongoing measurement and starts new measurements (depending on the respective bits).

## LS\_GAIN

Default Value: 01HEX

<b>7</b>	<b>6</b>	<b>5</b>	<b>4</b>	<b>3</b>	<b>2</b>	<b>1</b>	<b>0</b>	Gain Range	0x05
0	0	0	0	0					

Field	Bit	Description
Gain Range	2:0	000: Gain 1 001: Gain 3 010: Gain 6 011: Gain 9 100: Gain 18

The channels of the light sensor always run on the same gain range setting. Sensitivity settings correlate between the channels. Result output in Lux is available from ALS/green channel.

Writing to this register stops the ongoing measurement and starts new measurements (depending on the respective bits).

## PART\_ID

Default Value: B5HEX

<b>7</b>	<b>6</b>	<b>5</b>	<b>4</b>	<b>3</b>	<b>2</b>	<b>1</b>	<b>0</b>	Part ID	Revision ID	0x06

Field	Bit	Description
Part Number iD	7:4	Part number ID
Revision ID	3:0	Revision ID of the component

## MAIN\_STATUS

Default Value: 20HEX

<b>7</b>	<b>6</b>	<b>5</b>	<b>4</b>	<b>3</b>	<b>2</b>	<b>1</b>	<b>0</b>	
0	0	Power On Status	LS Interrupt Status	LS Data Status	0	0	0	0x07

Field	Bit	Description
Power On Status	5	1: Part went through a power-up event, either because the part was turned on or because there was power supply disturbance. All interrupt threshold settings in the registers have been reset to power-on default states and should be examined if necessary. The flag is cleared after the register is read.
LS Interrupt Status	4	0: Interrupt condition not fulfilled ( <b>default</b> ) 1: Interrupt condition fulfilled (cleared after read)
LS Data Status	3	0: Old data, already read ( <b>default</b> ) 1: New data, not yet read (cleared after read)

## LS\_DATA\_IR

Default Value: 00HEX, 00HEX, 00HEX

<b>7</b>	<b>6</b>	<b>5</b>	<b>4</b>	<b>3</b>	<b>2</b>	<b>1</b>	<b>0</b>	
LS_DATA_IR_0								0x0A
LS_DATA_IR_1								0x0B
0	0	0	0	LS_DATA_IR_2				0x0C

IR channel output data (unsigned integer, 13 to 20 bit, LSB aligned).

The IR channel output is already temperature compensated internally:

$LS\_DATA\_IR - (IR_{int} - LS\_DATA\_COMP)$

When an I<sup>2</sup>C read operation is active and points to an address in the range 07HEX to 18HEX, all registers in this range are locked until the I<sup>2</sup>C read operation is completed or this address range is left.

This guarantees that the data in the registers comes from the same measurement even if an additional measurement cycle ends during the read operation. New measurement data is stored into temporary registers and the actual LS\_DATA registers are updated as soon as there is no ongoing I<sup>2</sup>C read operation to the address range 07HEX to 18HEX.

Reg 0AHEX	Bit[7:0]	IR diode data least significant data byte
Reg 0BHEX	Bit[7:0]	IR diode data intervening data byte.
Reg 0CHEX	Bit[3:0]	IR diode data most significant data byte.

## LS\_DATA\_GREEN

Default Value: 00HEX, 00HEX, 00HEX

7	6	5	4	3	2	1	0	
LS_DATA_GREEN_0								0x0D
LS_DATA_GREEN_1								0x0E
0	0	0	0	LS_DATA_GREEN_2				0x0F

ALS/CS Green channel digital output data.

The channel output is already temperature compensated internally:

$$\text{LS\_DATA\_GREEN} = (\text{Greenint} - \text{LS\_DATA\_COMP})$$

When an I<sup>2</sup>C read operation is active and points to an address in the range 07HEX to 18HEX, all registers in this range are locked until the I<sup>2</sup>C read operation is completed or this address range is left.

This guarantees that the data in the registers comes from the same measurement even if an additional measurement cycle ends during the read operation. New measurement data is stored into temporary registers and the actual LS\_DATA registers are updated as soon as there is no ongoing I<sup>2</sup>C read operation to the address range 07HEX to 18HEX.

Reg 0DHEX	Bit[7:0]	ALS/Green diode data least significant data byte
Reg 0EHEX	Bit[7:0]	ALS/Green diode data intervening data byte.
Reg 0FHEX	Bit[3:0]	ALS/Green diode data most significant data byte.

## LS\_DATA\_BLUE

Default Value: 00HEX, 00HEX, 00HEX

7	6	5	4	3	2	1	0	
LS_DATA_BLUE_0								0x10
LS_DATA_BLUE_1								0x11
0	0	0	0	LS_DATA_BLUE_2				0x12

CS Blue channel output data.

The channel output is already temperature compensated internally:

$$\text{LS\_DATA\_BLUE} = (\text{Blueint} - \text{LS\_DATA\_COMP})$$

When an I<sup>2</sup>C read operation is active and points to an address in the range 07HEX to 18HEX, all registers in this range are locked until the I<sup>2</sup>C read operation is completed or this address range is left.

This guarantees that the data in the registers comes from the same measurement even if an additional measurement cycle ends during the read operation. New measurement data is stored into temporary registers and the actual LS\_DATA registers are updated as soon as there is no ongoing I<sup>2</sup>C read operation to the address range 07HEX to 18HEX.

Reg 10HEX	Bit[7:0]	Blue diode data least significant data byte
Reg 11HEX	Bit[7:0]	Blue diode data intervening data byte.
Reg 12HEX	Bit[3:0]	Blue diode data most significant data byte.

## LS\_DATA\_RED

Default Value: 00HEX, 00HEX, 00HEX

7	6	5	4	3	2	1	0	
LS_DATA_RED_0								0x13
LS_DATA_RED_1								0x14
0	0	0	0	LS_DATA_RED_2				0x15

The channel output is already temperature compensated internally:

$$\text{LS\_DATA\_RED} = (\text{Redint} - \text{LS\_DATA\_COMP})$$

When an I<sup>2</sup>C read operation is active and points to an address in the range 07HEX to 18HEX, all registers in this range are locked until the I<sup>2</sup>C read operation is completed or this address range is left.

This guarantees that the data in the registers comes from the same measurement even if an additional measurement cycle ends during the read operation. New measurement data is stored into temporary registers and the actual LS\_DATA registers are updated as soon as there is no ongoing I<sup>2</sup>C read operation to the address range 07HEX to 18HEX.

Reg 13HEX	Bit[7:0]	Red diode data least significant data byte
Reg 14HEX	Bit[7:0]	Red diode data intervening data byte.
Reg 15HEX	Bit[3:0]	Red diode data most significant data byte.

## INT\_CFG

Default Value: 10HEX

<b>7</b>	<b>6</b>	<b>5</b>	<b>4</b>	<b>3</b>	<b>2</b>	<b>1</b>	<b>0</b>	0x19
0	0	LS_INT_SEL		LS_VAR_MODE	LS_INT_EN	0	0	

Field	Bit	Description
LS_INT_SEL	5:4	00: IR channel 01: ALS/Green channel ( <b>default</b> ) 10: Red channel 11: Blue channel
LS_VAR_MODE	3	0: LS threshold interrupt mode ( <b>default</b> ) 1: LS variation interrupt mode
LS_INT_EN	2	0: LS interrupt disabled ( <b>default</b> ) 1: LS interrupt enabled

## INT\_PERSISTENCE

Default Value: 00HEX

<b>7</b>	<b>6</b>	<b>5</b>	<b>4</b>	<b>3</b>	<b>2</b>	<b>1</b>	<b>0</b>	0x1A
LS_PERSIST				0	0	0	0	

This register sets the number of similar consecutive LS interrupt events that must occur before the interrupt is asserted.

Field	Bit	Description
LS_PERSIST	7:4	0000: Every LS value out of threshold range ( <b>default</b> ) asserts an interrupt 0001: 2 consecutive LS values out of threshold range assert an interrupt ... 1111: 16 consecutive LS values out of threshold range assert an interrupt



## LS\_THRES\_UP

Default Value: FFHEX, FFHEX, 0FHEX

7	6	5	4	3	2	1	0	
LS_THRES_UP_0								0x21
LS_THRES_UP_1								0x22
0	0	0	0	LS_THRES_UP_2				0x23

LS\_THRES\_UP sets the upper threshold value for the LS interrupt. The interrupt controller compares the value in LS\_THRES\_UP against measured data in the LS\_DATA registers of the selected LS interrupt channel. It generates an interrupt event if LS\_DATA exceeds the threshold level.

The data format for LS\_THRES\_UP must match that of the LS\_DATA registers.

Reg 21HEX	Bit[7:0]	LS upper interrupt threshold value, LSB
Reg 22HEX	Bit[7:0]	LS upper interrupt threshold value, intervening byte
Reg 23HEX	Bit[3:0]	LS upper interrupt threshold value, MSB

## LS\_THRES\_LOW

Default Value: 00HEX, 00HEX, 00HEX

7	6	5	4	3	2	1	0	
LS_THRES_LOW_0								0x24
LS_THRES_LOW_1								0x25
0	0	0	0	LS_THRES_LOW_2				0x26

LS\_THRES\_LOW sets the lower threshold value for the LS interrupt. The Interrupt Controller compares the value in LS\_THRES\_LOW against measured data in the LS\_DATA registers of the selected LS interrupt channel. It generates an interrupt event if the LS\_DATA is below the threshold level.

The data format for LS\_THRES\_LOW must match that of the LS\_DATA registers.

Reg 24HEX	Bit[7:0]	LS lower interrupt threshold value, LSB
Reg 25HEX	Bit[7:0]	LS lower interrupt threshold value, intervening byte
Reg 26HEX	Bit[3:0]	LS lower interrupt threshold value, MSB

# LS\_THRES\_VAR

Default Value: 00HEX

7	6	5	4	3	2	1	0	LS_THES_VAR	0x27
0	0	0	0	0					

Field	Bit	Description
LS_THRES_VAR	2:0	000: LS result varies by 8 counts compared to previous result ( <b>default</b> ) 001: LS result varies by 16 counts compared to previous result 010: LS result varies by 32 counts compared to previous result 011: LS result varies by 64 counts compared to previous result ... 111: LS result varies by 1024 counts compared to previous result

## Application Information Hardware

The application hardware circuit for using implementing RGB, ALS, and IR solution is simple with the APDS-9250 and is shown in following figure. The bypass capacitor is placed as close to the device package and is connected directly to the power source and to the ground, as shown in the following figure. It allows the AC component of the VDD to pass through to ground. Suggested to have bypass capacitor that have low effective series resistance (ESR) and low effective series inductance (ESI), such as the common ceramic types, which provide a low impedance path to ground at high frequencies to handle transient currents caused by internal logic switching.

Pull-up resistors, RSDA and RSCL, maintain the SDA and SCL lines at a high level when the bus is free and ensure the signals are pulled up from a low to a high level within the required rise time. A pull-up resistor, RINT, is also required for the interrupt (INT), which functions as a wired-AND signal in a similar fashion to the SCL and SDA lines. A typical impedance value of 10 kΩ can be used.

For a complete description of I<sup>2</sup>C maximum and minimum R1 and R2 values, review the I<sup>2</sup>C Specification at <http://www.semiconductors.philips.com>.

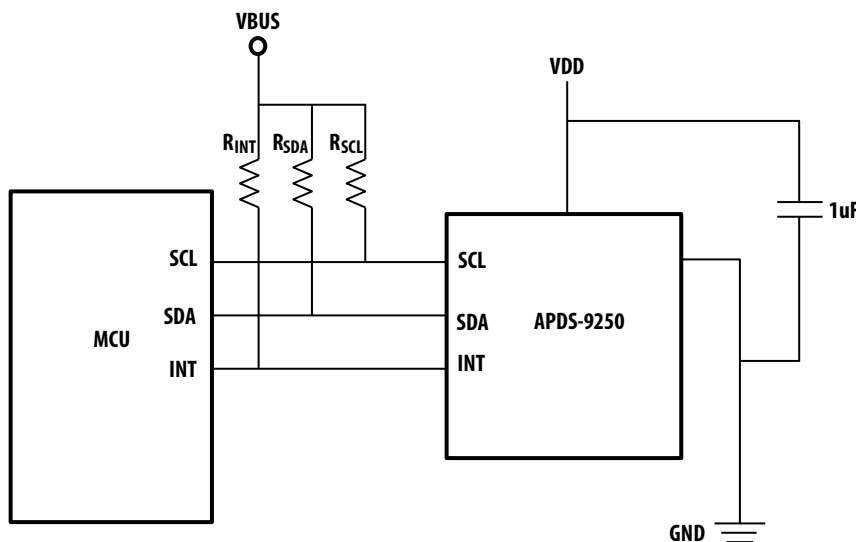

# Package Outline Dimensions

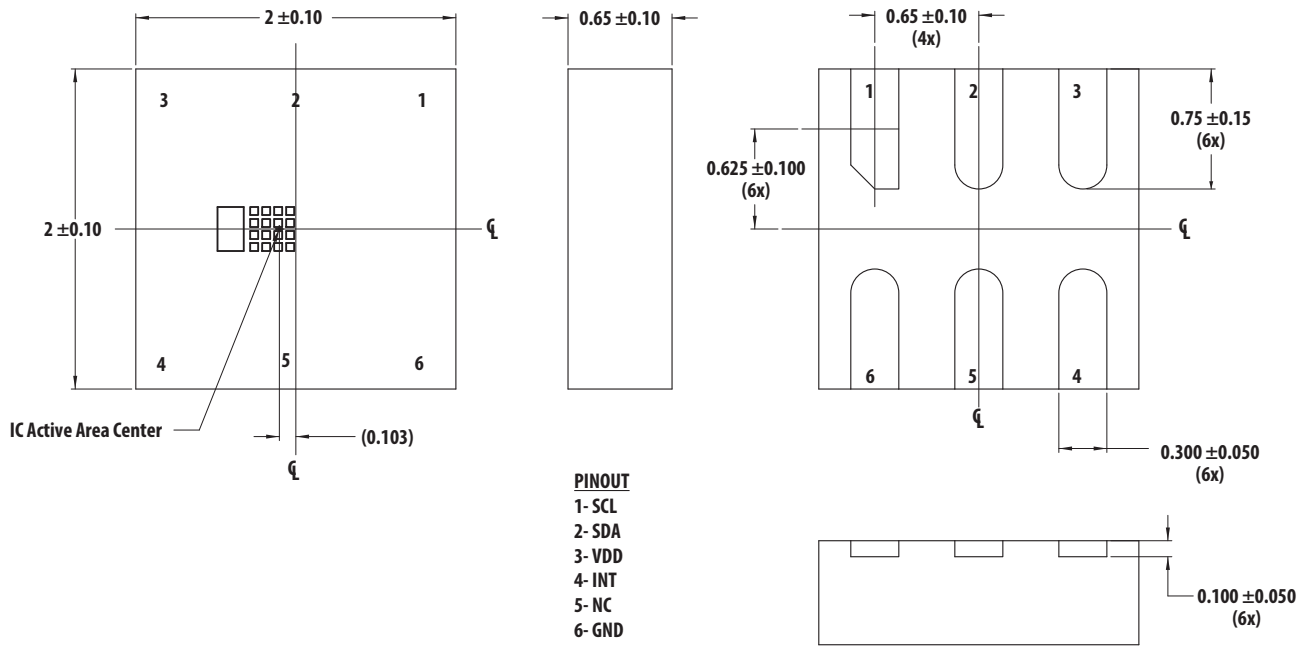

**NOTE:** All dimensions are in mm.

# PCB Pad Layout

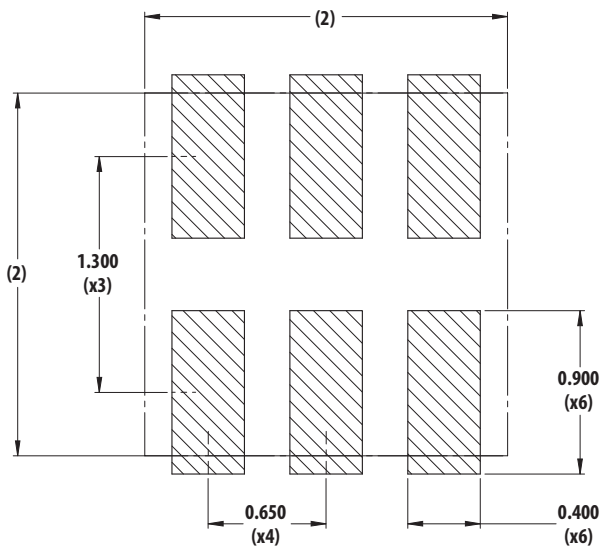

**NOTE:** All dimensions are in mm.

# Tape Dimensions

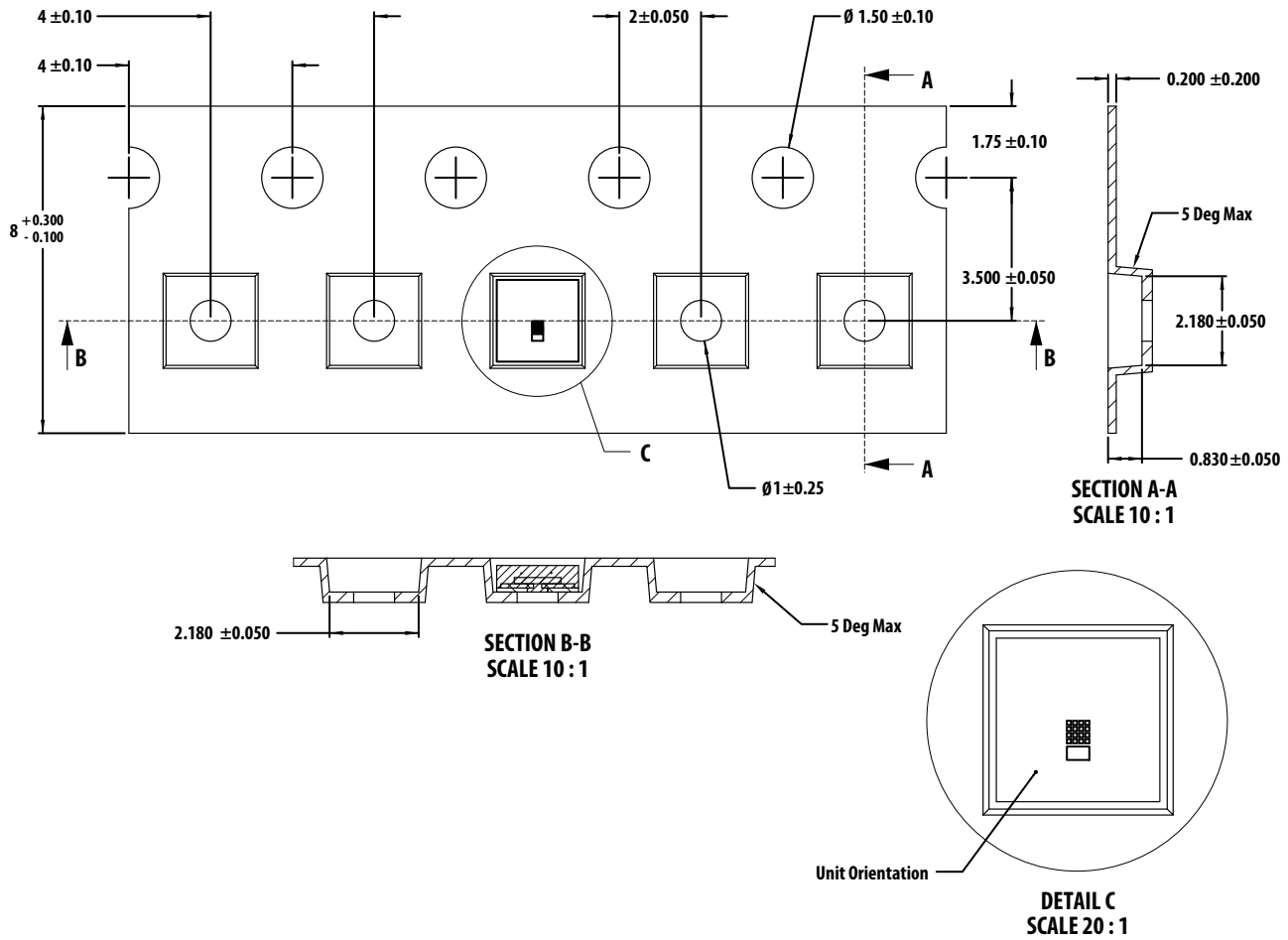

**NOTE:** All dimensions are in mm.

# Reel Dimensions

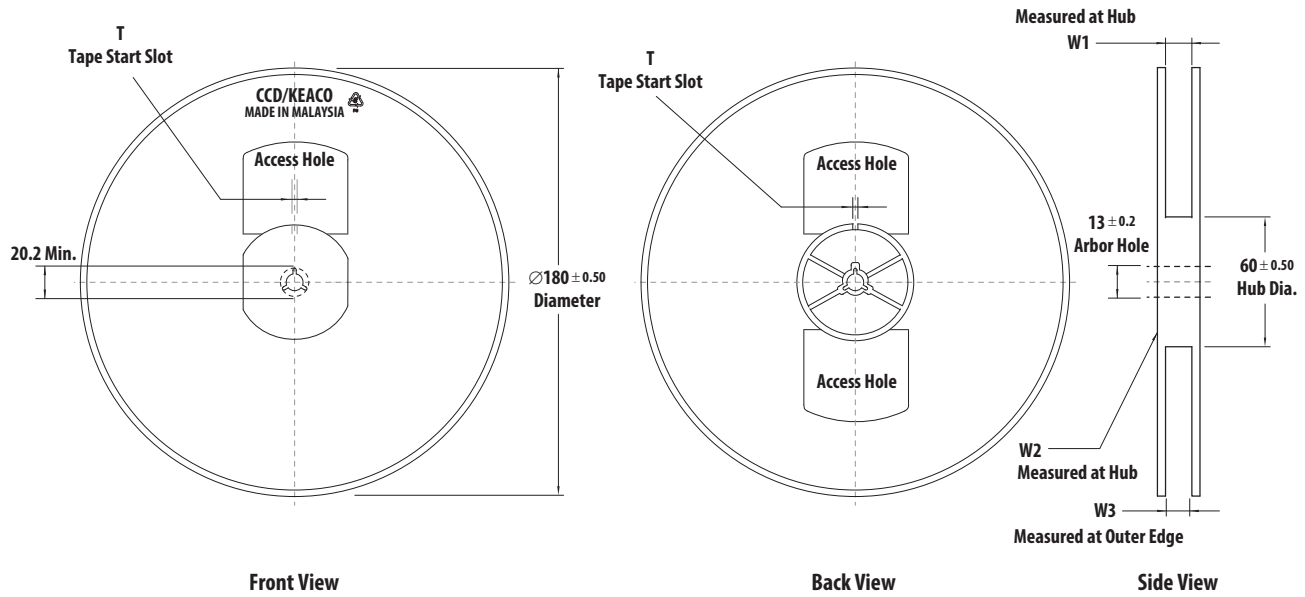

Tape Width	T	W1	W2	W3
8 mm	$3 \pm 0.5$	$8.4 + 1.5$ $- 0.0$	14.4 max.	7.9 min. 10.9 max.

**NOTE:** All dimensions are in mm.

# Moisture Proof Packaging

All APDS-9250 options are shipped in moisture proof package. When opened, moisture absorption begins. This part is compliant to JEDEC MSL 3.

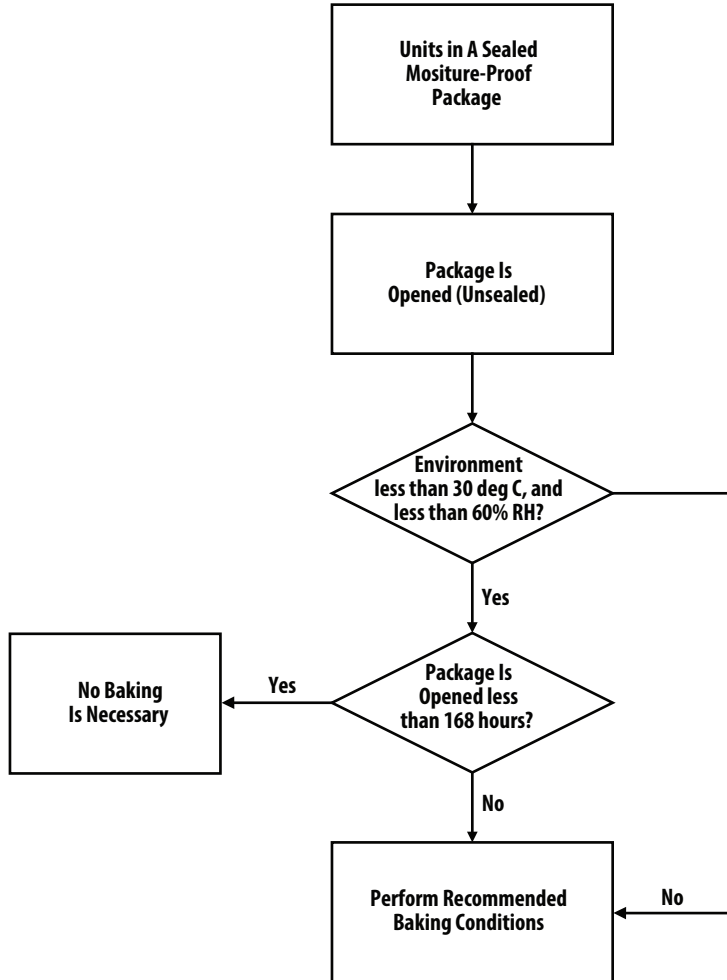

## Recommended Storage Conditions

Storage Temperature	10°C to 30°C
Relative Humidity	Below 60% RH

## Time from Unsealing to Soldering

After removal from the bag, the parts should be soldered within seven days if stored at the recommended storage conditions. When the moisture barrier bag (MBB) is opened and the parts are exposed to the recommended storage conditions more than seven days the parts must be baked before reflow to prevent damage to the parts.

## Baking Conditions

If the parts are not stored per the recommended storage conditions they must be baked before reflow to prevent damage to the parts.

Package	Temperature	Time
In Reel	60°C	48 hours
In Bulk	100°C	4 hours

**NOTE:** Baking should only be done once.

## Recommended Reflow Profile

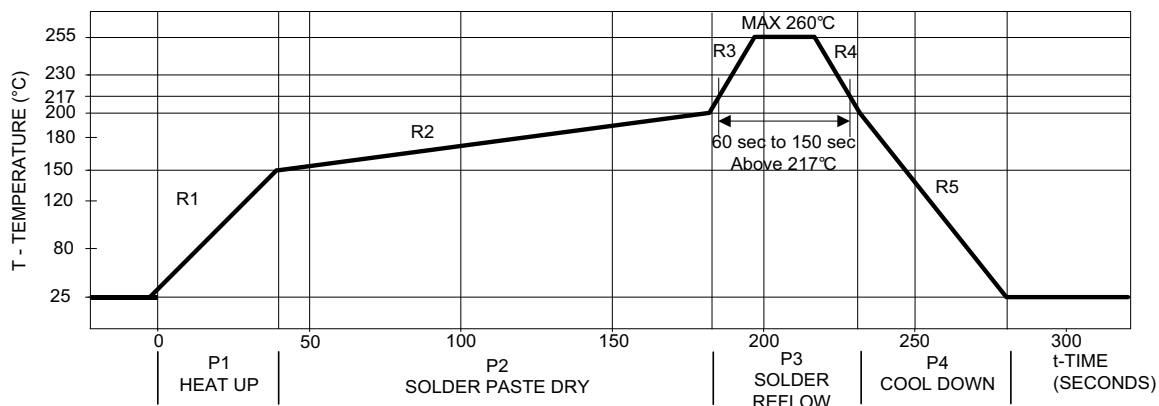

Process Zone	Symbol	$\Delta T$	Maximum $\Delta T/\Delta \text{time}$ or Duration
Heat Up	P1, R1	25°C to 150°C	3°C/s
Solder Paste Dry	P2, R2	150°C to 200°C	60s to 120s
Solder Reflow	P3, R3	200°C to 260°C	3°C/s
	P3, R4	260°C to 200°C	-6°C/s
Cool Down	P4, R5	200°C to 25°C	-6°C/s
Time maintained above liquidus point, 217°C		> 217°C	60s to 150s
Peak Temperature		260°C	—
Time within 5 °C of actual Peak Temperature		> 255°C	30s
Time 25 °C to Peak Temperature		25°C to 260°C	8 minutes

The reflow profile is a straight-line representation of a nominal temperature profile for a convective reflow solder process. The temperature profile is divided into four process zones, each with different  $\Delta T/\Delta \text{time}$  temperature change rates or duration. The  $\Delta T/\Delta \text{time}$  rates or duration are detailed in the preceding table. The temperatures are measured at the component to printed circuit board connections.

In **process zone P1**, the PC board and component pins are heated to a temperature of 150°C to activate the flux in the solder paste. The temperature ramp up rate, R1, is limited to 3°C per second to allow for even heating of both the PC board and component pins.

**Process zone P2** should be of sufficient time duration (60s to 120s) to dry the solder paste. The temperature is raised to a level just below the liquidus point of the solder.

**Process zone P3** is the solder reflow zone. In zone P3, the temperature is quickly raised above the liquidus point of solder to 260°C (500°F) for optimum results. The dwell time

above the liquidus point of solder should be between 60s and 150s. This is to assure proper coalescing of the solder paste into liquid solder and the formation of good solder connections. Beyond the recommended dwell time the intermetallic growth within the solder connections becomes excessive, resulting in the formation of weak and unreliable connections. The temperature is then rapidly reduced to a point below the solidus temperature of the solder to allow the solder within the connections to freeze solid.

**Process zone P4** is the cool down after solder freeze. The cool down rate, R5, from the liquidus point of the solder to 25°C (77°F) should not exceed 6°C per second maximum. This limitation is necessary to allow the PC board and component pins to change dimensions evenly, putting minimal stresses on the component.

It is recommended to perform reflow soldering no more than three times.

Broadcom, the pulse logo, Connecting everything, Avago Technologies, Avago, and the A logo are among the trademarks of Broadcom and/or its affiliates in the United States, certain other countries and/or the EU.

Copyright © 2020–2021 Broadcom. All Rights Reserved.

The term “Broadcom” refers to Broadcom Inc. and/or its subsidiaries. For more information, please visit [www.broadcom.com](http://www.broadcom.com).

Broadcom reserves the right to make changes without further notice to any products or data herein to improve reliability, function, or design. Information furnished by Broadcom is believed to be accurate and reliable. However, Broadcom does not assume any liability arising out of the application or use of this information, nor the application or use of any product or circuit described herein, neither does it convey any license under its patent rights nor the rights of others.

