

## AFBR-S4K33P6425B

### 8 × 8 SiPM Array, WB-Type, 3 × 3 mm<sup>2</sup> Channel Size

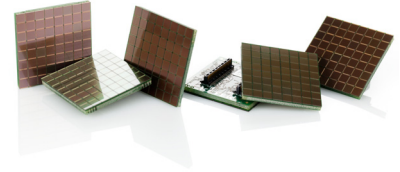

---

## Description

The Broadcom<sup>®</sup> AFBR-S4K33P6425B is a silicon photomultiplier (SiPM) array.

The four-side seamlessly tileable 8 × 8 array has an 80% fill factor based on a 3.0 × 3.0 mm<sup>2</sup> pixel size and a pixel pitch of 3.36 mm. Low voltage and excellent uniformity enables tight integration into medical imaging, handhelds, and optical sorting.

## Features

- 8 × 8 array, 3 × 3 mm<sup>2</sup> pixel size
- 3.36 mm pixel pitch
- Array fill factor 80%, four-side seamless tileable
- Replacement for PMTs, APDs, and PIN diodes
- Low voltage operation (typically about 30V)
- Excellent uniformity of  $V_{BD}$  with  $\pm 125$  mV

## Applications

- Positron emission tomography
- Scintillator readout
- Medical imaging
- Gamma and Compton cameras
- Handhelds
- High-energy physics and research
- Optical sorting
- Hazard and threat detection
- Analytical instrumentation

**NOTE:** All values in this data sheet are typical values if not marked with min., max., <, or >.

# Mechanical Specifications

Figure 1: AFBR-S4K33P6425B Dimensions

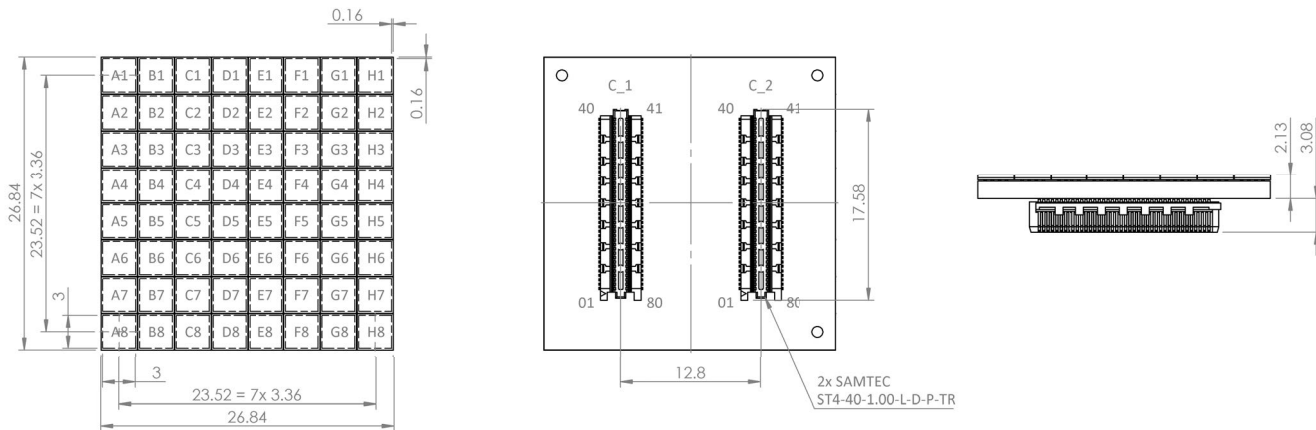

**NOTE:** General tolerances are  $\pm 0.1$  mm unless otherwise noted.

## General Parameters and Ordering Information

Type	Active Area of SiPM Pixel [mm <sup>2</sup> ]	Microcell Size of SiPM Pixel [ $\mu$ m]	SiPM Pixel Pitch in Array [mm]	Array Dimensions [mm <sup>3</sup> ]
AFBR-S4K33P6425B based on AFBR-S4K33C0125B SiPM <sup>a</sup>	3.0 × 3.0	25	3.36	26.835 × 26.835 × 5.4

a. Full SiPM specification can be found in the corresponding SiPM Datasheet of AFBR-S4K33C0125B at <https://www.broadcom.com/products/optical-sensors/silicon-photomultiplier-sipm>.

## Main Characteristics

Parameter	Min.	Typ.	Max.	Units
Breakdown Voltage ( $V_{BD}$ ) at 21°C	24.0	—	25.0	V
Breakdown Voltage Variation per Array	—	$\pm 0.125$	—	V
Recommended Overvoltage ( $V_{OV}$ )	—	2.0 to 5.0	6.0	V
Temperature Dependency of $V_{BD}$	—	22.0	—	mV/K
Temperature Dependency of Gain	—	0.3% at 5.0 $V_{OV}$	—	1/K
Operating Temperature Range	-40	—	+60	°C
Reliability Classification	—	MSL1	—	
Index of Refraction of Glass Entrance Window	—	1.52 at 430 nm	—	
Surface Roughness of the Array	—	< 10	—	$\mu$ m (sigma)

# Typical Performance Characteristics

Figure 2: Photo Detection Efficiency at 5V Overvoltage

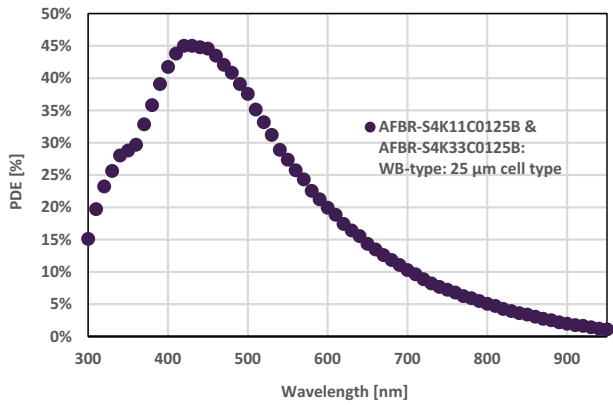

Figure 3: Coincidence Time Resolution with LYSO 2 × 2 × 3 mm<sup>3</sup> Measured with PETSys TOFPET2 ASIC

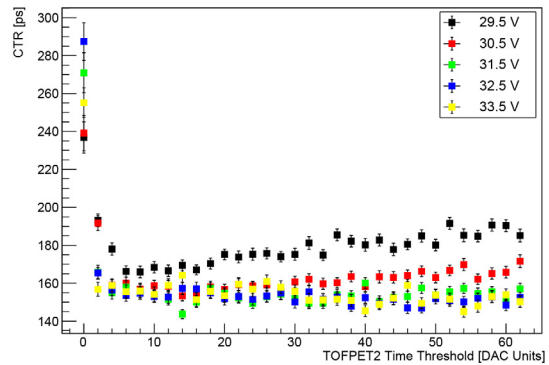

Figure 4: Coincidence Time Resolution with LYSO 3 × 3 × 20 mm<sup>3</sup> at 5V Overvoltage

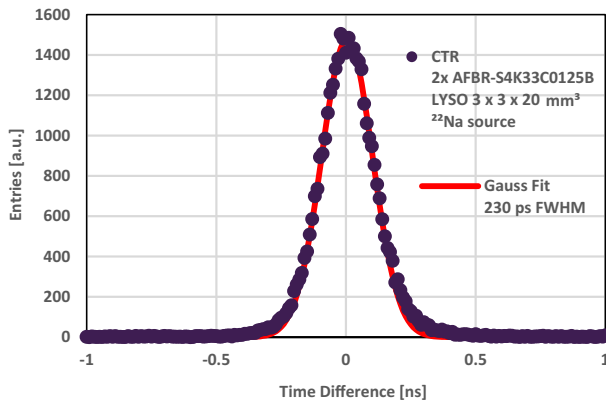

Figure 5: Energy Spectrum with LYSO 3 × 3 × 5 mm<sup>3</sup> Measured with PETSysTOFPET2 ASIC

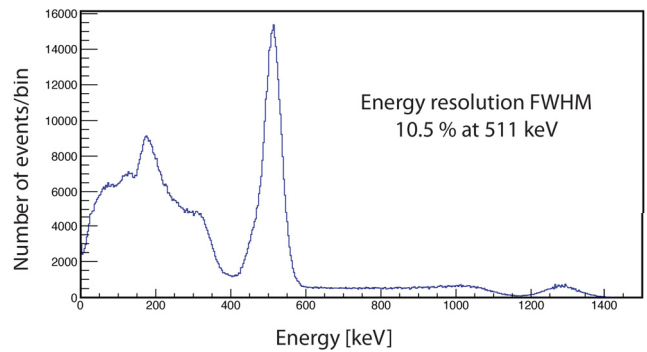

Figure 6: Energy Spectrum with LYSO 3 × 3 × 20 mm<sup>3</sup> Measured with Vertilon ISQP582

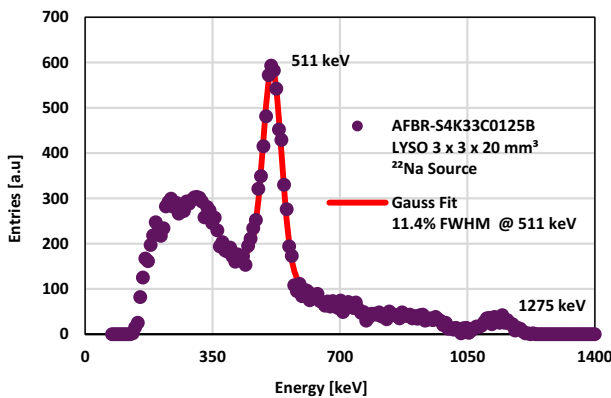
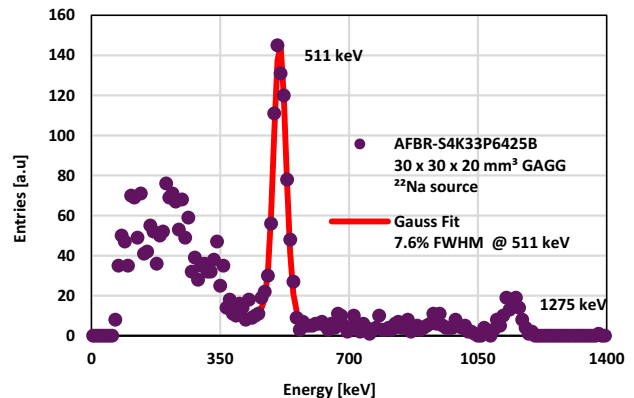

Figure 7: Energy Spectrum with Monolithic GAGG 30 × 30 × 20 mm<sup>3</sup> Measured with Vertilon ISQP582



## Pin Mapping

Connector C_1			
SAMTEC ST4-40-1.00-L-D-P-TR <sup>a</sup>			
Pin	SiPM Pixel	Pin	SiPM Pixel
1	Cathode (G8)	41	Cathode (F1)
2	Cathode (H8)	42	Cathode (E1)
3	NC <sup>b</sup>	43	NC
4	Anode (G8)	44	Anode (F1)
5	Anode (H8)	45	Anode (E1)
6	Anode (H7)	46	Anode (E2)
7	Anode (G7)	47	Anode (F2)
8	NC	48	NC
9	Cathode (H7)	49	Cathode (E2)
10	Cathode (G7)	50	Cathode (F2)
11	Cathode (G6)	51	Cathode (F3)
12	Cathode (H6)	52	Cathode (E3)
13	NC	53	NC
14	Anode (G6)	54	Anode (F3)
15	Anode (H6)	55	Anode (E3)
16	Anode (H5)	56	Anode (E4)
17	Anode (G5)	57	Anode (F4)
18	NC	58	NC
19	Cathode (H5)	59	Cathode (E4)
20	Cathode (G5)	60	Cathode (F4)
21	Cathode (G4)	61	Cathode (F5)
22	Cathode (H4)	62	Cathode (E5)
23	NC	63	NC
24	Anode (G4)	64	Anode (F5)
25	Anode (H4)	65	Anode (E5)
26	Anode (H3)	66	Anode (E6)
27	Anode (G3)	67	Anode (F6)
28	NC	68	NC
29	Cathode (H3)	69	Cathode (E6)
30	Cathode (G3)	70	Cathode (F6)
31	Cathode (G2)	71	Cathode (F7)
32	Cathode (H2)	72	Cathode (E7)
33	NC	73	NC
34	Anode (G2)	74	Anode (F7)
35	Anode (H2)	75	Anode (E7)
36	Anode (H1)	76	Anode (E8)
37	Anode (G1)	77	Anode (F8)
38	NC	78	NC

Connector C_2			
SAMTEC ST4-40-1.00-L-D-P-TR <sup>a</sup>			
Pin	SiPM Pixel	Pin	SiPM Pixel
1	Cathode (C8)	41	Cathode (B1)
2	Cathode (D8)	42	Cathode (A1)
3	NC	43	NC
4	Anode (C8)	44	Anode (B1)
5	Anode (D8)	45	Anode (A1)
6	Anode (D7)	46	Anode (A2)
7	Anode (C7)	47	Anode (B2)
8	NC	48	NC
9	Cathode (D7)	49	Cathode (A2)
10	Cathode (C7)	50	Cathode (B2)
11	Cathode (C6)	51	Cathode (B3)
12	Cathode (D6)	52	Cathode (A3)
13	NC	53	NC
14	Anode (C6)	54	Anode (B3)
15	Anode (D6)	55	Anode (A3)
16	Anode (D5)	56	Anode (A4)
17	Anode (C5)	57	Anode (B4)
18	NC	58	NC
19	Cathode (D5)	59	Cathode (A4)
20	Cathode (C5)	60	Cathode (B4)
21	Cathode (C4)	61	Cathode (B5)
22	Cathode (D4)	62	Cathode (A5)
23	NC	63	NC
24	Anode (C4)	64	Anode (B5)
25	Anode (D4)	65	Anode (A5)
26	Anode (D3)	66	Anode (A6)
27	Anode (C3)	67	Anode (B6)
28	NC	68	NC
29	Cathode (D3)	69	Cathode (A6)
30	Cathode (C3)	70	Cathode (B6)
31	Cathode (C2)	71	Cathode (B7)
32	Cathode (D2)	72	Cathode (A7)
33	NC	73	NC
34	Anode (C2)	74	Anode (B7)
35	Anode (D2)	75	Anode (A7)
36	Anode (D1)	76	Anode (A8)
37	Anode (C1)	77	Anode (B8)
38	NC	78	NC

Connector C_1			
SAMTEC ST4-40-1.00-L-D-P-TR <sup>a</sup>			
Pin	SiPM Pixel	Pin	SiPM Pixel
39	Cathode (H1)	79	Cathode (E8)
40	Cathode (G1)	80	Cathode (F8)

Connector C_2			
SAMTEC ST4-40-1.00-L-D-P-TR <sup>a</sup>			
Pin	SiPM Pixel	Pin	SiPM Pixel
39	Cathode (D1)	79	Cathode (A8)
40	Cathode (C1)	80	Cathode (88)

a. SAMTEC ST4-40-1.00-L-D-P-TR mates with SAMTEC SS4-40-3.00-L-D-K-TR, mated stacking height 4 mm.

b. NC = Not Connected.

Copyright © 2017–2021 Broadcom. All Rights Reserved. The term “Broadcom” refers to Broadcom Inc. and/or its subsidiaries. For more information, go to [www.broadcom.com](http://www.broadcom.com). All trademarks, trade names, service marks, and logos referenced herein belong to their respective companies.

Broadcom reserves the right to make changes without further notice to any products or data herein to improve reliability, function, or design. Information furnished by Broadcom is believed to be accurate and reliable. However, Broadcom does not assume any liability arising out of the application or use of this information, nor the application or use of any product or circuit described herein, neither does it convey any license under its patent rights nor the rights of others.

