

AEDR-9940

Three-Channel Reflective Incremental Encoder with Analog or Digital Differential Output (198.4 LPI)

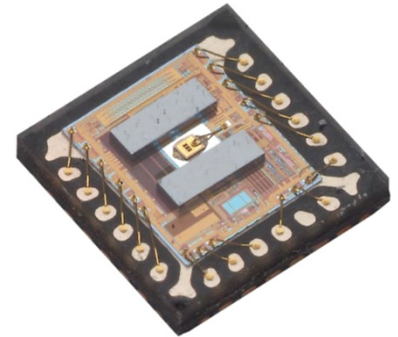

Description

The AEDR-9940 is a three-channel reflective optical encoder. Selectable and programmable options are available for three-channel digital or analog differential A, B, and I output.

The AEDR-9940 in analog encoder modes, with three-channel differential analog outputs (Sine+, Sine-; Cos+, Cos-; I+, I-), can be interfaced directly with available external interpolators.

The AEDR-9940 digital encoder mode offers two-channel (AB) quadrature digital outputs and a third channel digital index outputs. Being TTL compatible, the outputs of the AEDR-9940 encoder can be interfaced with most of the signal processing circuitries. Hence the encoder provides easy integration and flexible design-in into existing systems.

The AEDR-9940 encoder is designed to operate from -40°C to 115°C and is suitable for commercial, industrial, and automotive end applications.

The encoder houses an LED light source and photo-detecting circuitry in a single package. The small size of $4.0\text{ mm (L)} \times 4.0\text{ mm (W)} \times 0.7\text{ mm (H)}$ allows it to be used in a wide range of miniature commercial applications where size and space are a primary concern.

NOTE: This product is not specifically designed or manufactured for use in any specific device. Customers are solely responsible for determining the suitability of this product for its intended application and solely liable for all loss, damage, expense, or liability in connection with such use.

Features

- Analog output option: Three-channel single-ended and differential analog output and analog or digital index output
- Digital output option: Three-channel differential or TTL compatible; two-channel quadrature (AB) digital outputs for direction sensing and a third channel, index (I) digital output
- Wide selection of built-in interpolators with 1X to 6X, 8X, 9X, 10X, 12X, 16X, 20X, 25X, 32X, 50X, 64X, 80X, 100X, 128X, 160X, 256X, 320X, 640X to 1000X
- SPI programmable interpolator from 1X to 1024X
- Surface-mount leadless package: $4.0\text{ mm (L)} \times 4.0\text{ mm (W)} \times 0.7\text{ mm (H)}$
- Operating voltage of 3.3V and 5.0V supply
- Built-in LED current regulation
- Wide operating temperature range from -40°C to 115°C
- High encoding resolution: 198.4375 LPI (lines/inch) or 7.8125 LP mm (lines/mm) or 0.128 mm (pitch)
- Translucent protection compound

Applications

- Closed-loop stepper motors
- Small motors, actuators
- Industrial printers
- Robotics
- Card readers
- PTZ camera
- Portable medical equipment
- Optometric equipment
- Linear stages

Output Waveform

Figure 1: Sample Output Waveforms

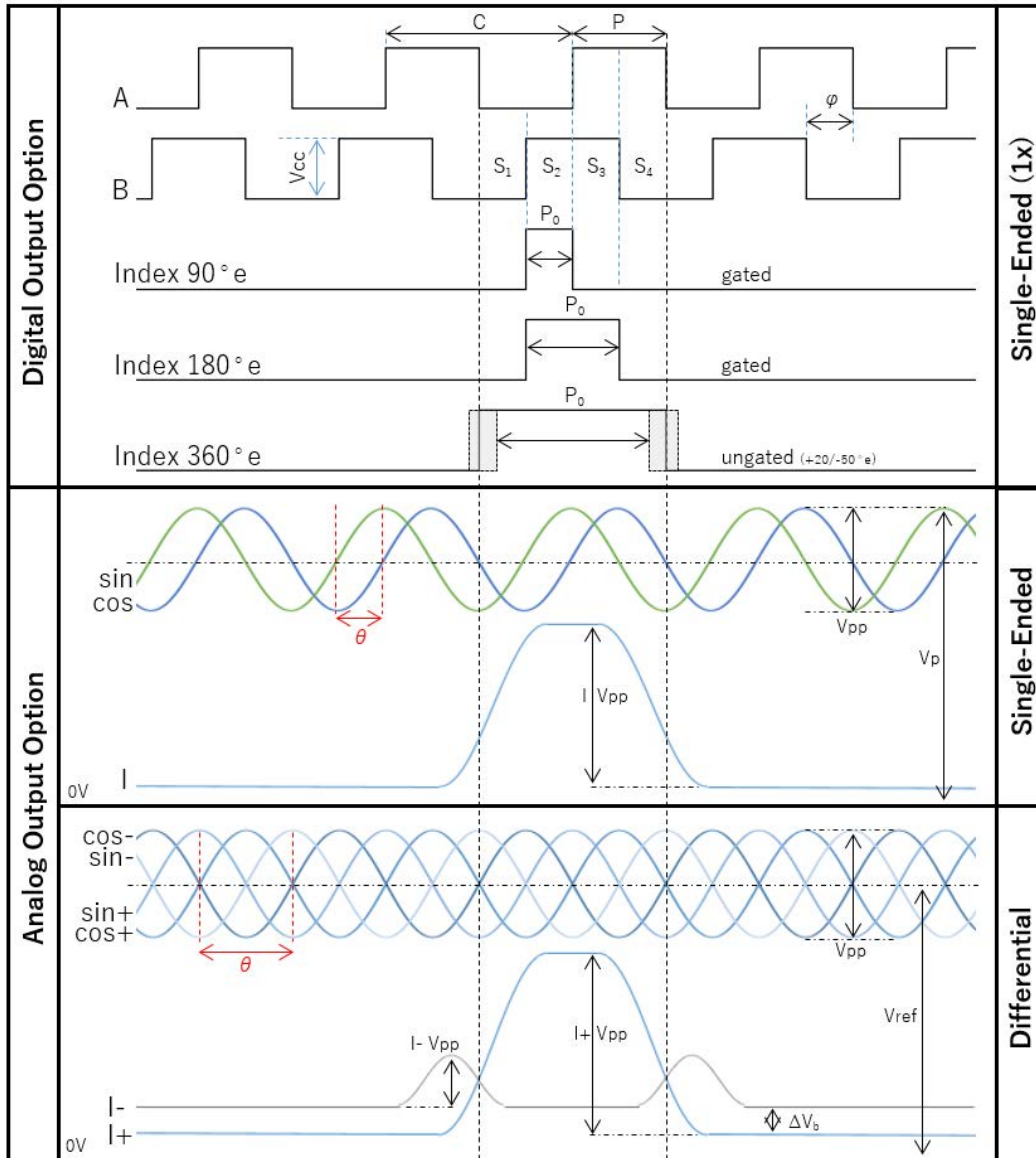
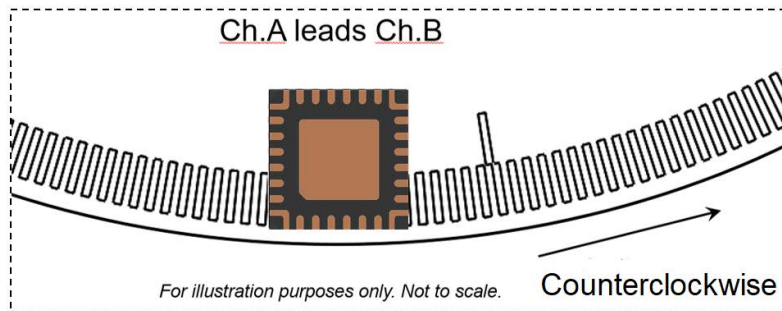

Figure 2: Top View: Code Wheel Movement Direction versus Output Signals



Digital Parameter Definitions

Parameter	Symbol	Definition
Count	N	The number of bar and window pairs or counts per revolution (CPR) of the code wheel.
Cycle	C	360 electrical degrees ($^{\circ}$ e), one bar and window pair. One shaft rotation: 360 mechanical degrees, N cycles.
Cycle Error	ΔC	An indication of cycle uniformity. The difference between an observed shaft angle, which gives rise to one electrical cycle, and the nominal angular increment of $1/N$ of a revolution.
Pulse Width (Duty) Error	ΔP	The deviation, in electrical degrees, of the pulse width from its ideal value of 180° e.
State	S	The number of electrical degrees between a transition in the output of Channel A and the neighboring transition in the output of Channel B. There are four states per cycle, each nominally 90° e.
Phase	ϕ	The number of electrical degrees between the center of the high state of Channel A and the center of the high state of Channel B. This value is nominally 90° e for quadrature output.
Optical Radius	R_{OP}	The distance from the code wheel's center of rotation to the optical center (OC) of the encoder module.
Index Pulse Width	P_0	The number of electrical degrees that an index is high during one full shaft rotation.

Analog Parameter Definitions

Parameter	Symbol	Definition
Analog Peak-to-Peak	V_{pp}	The peak-to-peak signal magnitude in V of the analog signals.
Reference Voltage	V_{ref}	The offset in V of the midpoint of the analog signal peak-to-peak to the zero voltage point. $V_{ref} = V_{CC}/2$
Analog Peak Voltage/ Valley Voltage	V_p	The value in V of the peak/valley of the analog signals (one-sided reading).
Analog Minimum Voltage	V_{min}	The value in V of the depth of the analog signals (minimum reading in V). $V_{min} = V_p - V_{pp}$
Analog Index Vbias (delta)	ΔV_b	The absolute difference of the Indexes $V_{bias} = I+ V_{min} - I- V_{min}$. The minimum value of ΔV_b is 200 mV.
Phase Shift	θ	The value in $^{\circ}$ e of the phase between two analog signals. Single-Ended mode; Cosine leads Sine by 90° e. Differential mode; Cosine+ leads Cosine- by 180° e (or Sine- lags by 180° e from Sine+).

Absolute Maximum Ratings

Parameter	Symbol	Value
Storage Temperature	T_S	-40°C to 125°C
Operating Temperature	T_A	-40°C to 115°C
Supply Voltage	V_{CC}	5.5V

NOTE:

- Proper operation of the encoder is not guaranteed if the maximum ratings are exceeded.
- Exposure to extreme light intensity (such as from flashbulbs or spotlights) can cause permanent damage to the device.
- Caution: Anti-static discharge precautions must be taken when handling the encoder to avoid damage or degradation induced by ESD.
- Some particles might be present on the encoder surface after SMT reflow or handling during assembly. Clean the encoder surface gently if particles are present.

Recommended Operating Conditions

Parameter	Symbol	Min.	Typ.	Max.	Unit	Note
Supply Voltage	V_{CC}	3.0	3.3	3.6	V	Ripple <100 mVpp, $V_{CC} = V_{DD}$
		4.5	5.0	5.5	V	
Current Consumption	I_{CC}	—	45	—	mA	Dependent on the spatial position and rotational speed
Pin Current (All I/O Outputs)	I	-20	—	20	mA	—
Maximum Output Frequency (External Mode Selection)	f	—	—	0.25	MHz	Interpolation: 1X
		—	—	0.50	MHz	Interpolation: 2X
		—	—	1.00	MHz	Interpolation: 4X
		—	—	2.00	MHz	Interpolation: 8X
		—	—	4.00	MHz	Interpolation: 16X
		—	—	4.00	MHz	Interpolation: 32X
		—	—	4.00	MHz	Interpolation: 64X
		—	—	4.00	MHz	Interpolation: 128X
Maximum Output Frequency (SPI Programmable)	f	—	—	4.00	MHz	Interpolation $\geq 16X$
Tangential Misalignment	ET	—	—	± 0.35	mm	CPR dependent.
Radial Misalignment	ER	—	—	± 0.35	mm	With AutoCal: 128 CPR = ± 0.25 mm 625 CPR = ± 0.35 mm 1000 CPR = ± 0.35 mm Without AutoCal: >512 CPR = ± 0.25 mm
Code Wheel Gap	G	0.85	1.35	2.35	mm	For typical 625 CPR
		0.85	1.35	1.85	mm	≤ 128 CPR
Specular Reflectance	R_f	60%	—	—	—	Reflective area
		—	—	5%	—	Nonreflective area
Tri-state Voltage Threshold	High	90	—	—	$\%V_{CC}$	—
	Low	—	—	10	$\%V_{CC}$	—
	Open	30	—	70	$\%V_{CC}$	—

Power-Up Behavior

When the AEDR-9940 is powered on, the digital output A, B, and Index will be in idle state until either the A or B digital signal is toggled. This duration is also called the startup phase, where the encoder is in recognition mode to verify the logic and the code wheel position.

Encoder Pinout

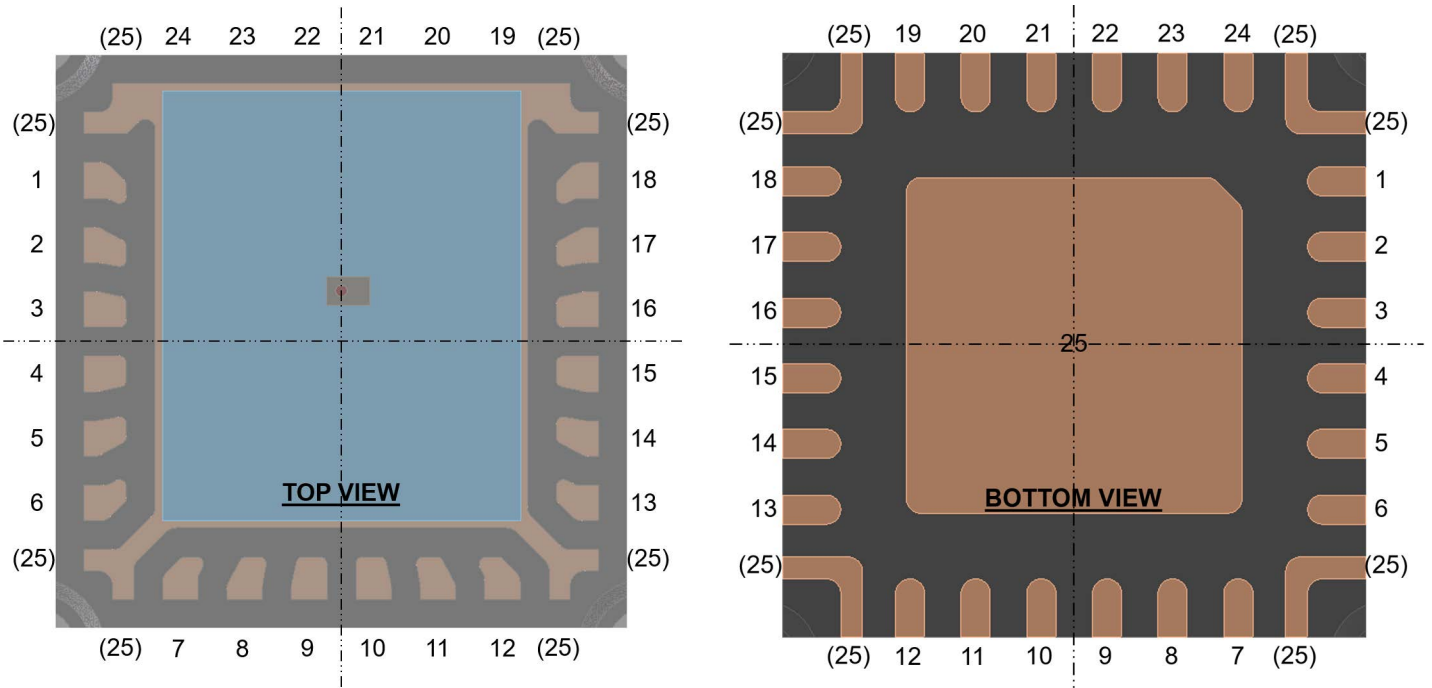

Table 1: AEDR-9940 Pinout

Pin	Name	Function
1	CH_A+	Digital A+ or Analog Sine+
2	CH_A- / SPI_DIN	Digital A- or Analog Sine- / SPI Data In
3	VDD5V	Digital Supply Voltage
4	VSSD	Digital Ground
5	CAL	Auto Calibration
6	CAL_STAT	Calibration Status
7	LEDERR	LED Error Indicator
8	INDEXSEL	Index Selection
9	CH_I- / 100k_CLK	Digital or Analog Index- / 100k Clock
10	CH_I+ / SPI_DOUT	Digital or Analog Index+ / SPI Data Out
11	N.C. ^a	—
12	SEL3	Mode Selection 3
13	SEL2	Mode Selection 2

a. N.C. = No connect.

Pin	Name	Function
14	SEL1	Mode Selection 1
15	VSSA	Analog Ground
16	VDDA	Analog Supply Voltage
17	CH_B- / SPI_CLK	Digital B- or Analog Cosine- / SPI Clock
18	CH_B+	Digital B+ or Analog Cosine+
19	N.C.	—
20	N.C.	—
21	N.C.	—
22	N.C.	—
23	N.C.	—
24	N.C.	—
25	VSSA	Analog Ground
(25)	N.C.	—

NOTE: No connection to all corner pads indicated as (25).

Select Options – AEDR-9940 Built-in Interpolation Factor

By configuring the selection pins, the user can select an interpolation factor from 1X to 1000X without accessing through SPI communication.

No.	SEL1	SEL2	SEL3	Interpolation Factor	INDEXSEL	Index
1	Low	Low	Low	1X	Low	Interpolation 1X - Index Gated 90 degrees
					High	Interpolation 1X - Index Gated 180 degrees
					Open	Interpolation 1X - Index Raw (Ungated)
2	High	Low	Low	2X	Low	Interpolation 2X - Index Gated 90 degrees
					High	Interpolation 2X - Index Gated 180 degrees
					Open	Interpolation 2X - Index Gated 360 degrees
3	Open ^a	Low	Low	3X	Low	Interpolation 3X - Index Gated 90 degrees
					High	Interpolation 3X - Index Gated 180 degrees
					Open	Interpolation 3X - Index Gated 360 degrees
4	Low	High	Low	4X	Low	Interpolation 4X - Index Gated 90 degrees
					High	Interpolation 4X - Index Gated 180 degrees
					Open	Interpolation 4X - Index Gated 360 degrees
5	High	High	Low	5X	Low	Interpolation 5X - Index Gated 90 degrees
					High	Interpolation 5X - Index Gated 180 degrees
					Open	Interpolation 5X - Index Gated 360 degrees
6	Open ^a	High	Low	6X	Low	Interpolation 6X - Index Gated 90 degrees
					High	Interpolation 6X - Index Gated 180 degrees
					Open	Interpolation 6X - Index Gated 360 degrees
7	Low	Open ^a	Low	8X	Low	Interpolation 8X - Index Gated 90 degrees
					High	Interpolation 8X - Index Gated 180 degrees
					Open	Interpolation 8X - Index Gated 360 degrees
8	High	Open ^a	Low	9X	Low	Interpolation 9X - Index Gated 90 degrees
					High	Interpolation 9X - Index Gated 180 degrees
					Open	Interpolation 9X - Index Gated 360 degrees
9	Open ^a	Open ^a	Low	10X	Low	Interpolation 10X - Index Gated 90 degrees
					High	Interpolation 10X - Index Gated 180 degrees
					Open	Interpolation 10X - Index Gated 360 degrees
10	Low	Low	High	12X	Low	Interpolation 12X - Index Gated 90 degrees
					High	Interpolation 12X - Index Gated 180 degrees
					Open	Interpolation 12X - Index Gated 360 degrees
11	High	Low	High	16X	Low	Interpolation 16X - Index Gated 90 degrees
					High	Interpolation 16X - Index Gated 180 degrees
					Open	Interpolation 16X - Index Gated 360 degrees
12	Open ^a	Low	High	20X	Low	Interpolation 20X - Index Gated 90 degrees
					High	Interpolation 20X - Index Gated 180 degrees
					Open	Interpolation 20X - Index Gated 360 degrees
13	Low	High	High	25X	Low	Interpolation 25X - Index Gated 90 degrees
					High	Interpolation 25X - Index Gated 180 degrees
					Open	Interpolation 25X - Index Gated 360 degrees

No.	SEL1	SEL2	SEL3	Interpolation Factor	INDEXSEL	Index
14	High	High	High	32X	Low	Interpolation 32X - Index Gated 90 degrees
					High	Interpolation 32X - Index Gated 180 degrees
					Open	Interpolation 32X - Index Gated 360 degrees
15	Open ^a	High	High	50X	Low	Interpolation 50X - Index Gated 90 degrees
					High	Interpolation 50X - Index Gated 180 degrees
					Open	Interpolation 50X - Index Gated 360 degrees
16	Low	Open ^a	High	64X	Low	Interpolation 64X - Index Gated 90 degrees
					High	Interpolation 64X - Index Gated 180 degrees
					Open	Interpolation 64X - Index Gated 360 degrees
17	High	Open ^a	High	80X	Low	Interpolation 80X - Index Gated 90 degrees
					High	Interpolation 80X - Index Gated 180 degrees
					Open	Interpolation 80X - Index Gated 360 degrees
18	Open ^a	Open ^a	High	100X	Low	Interpolation 100X - Index Gated 90 degrees
					High	Interpolation 100X - Index Gated 180 degrees
					Open	Interpolation 100X - Index Gated 360 degrees
19	Low	Low	Open ^a	128X	Low	Interpolation 128X - Index Gated 90 degrees
					High	Interpolation 128X - Index Gated 180 degrees
					Open	Interpolation 128X - Index Gated 360 degrees
20	High	Low	Open ^a	160X	Low	Interpolation 160X - Index Gated 90 degrees
					High	Interpolation 160X - Index Gated 180 degrees
					Open	Interpolation 160X - Index Gated 360 degrees
21	Open ^a	Low	Open ^a	256X	Low	Interpolation 256X - Index Gated 90 degrees
					High	Interpolation 256X - Index Gated 180 degrees
					Open	Interpolation 256X - Index Gated 360 degrees
22	Low	High	Open ^a	320X	Low	Interpolation 320X - Index Gated 90 degrees
					High	Interpolation 320X - Index Gated 180 degrees
					Open	Interpolation 320X - Index Gated 360 degrees
23	High	High	Open ^a	640X	Low	Interpolation 640X - Index Gated 90 degrees
					High	Interpolation 640X - Index Gated 180 degrees
					Open	Interpolation 640X - Index Gated 360 degrees
24	Open ^a	High	Open ^a	1000X	Low	Interpolation 1000X - Index Gated 90 degrees
					High	Interpolation 1000X - Index Gated 180 degrees
					Open	Interpolation 1000X - Index Gated 360 degrees
25	Low	Open ^a	Open ^a	Ungated Digital	Low	Analog SIN/COS (500 mVpp), Digital Index (Ungated)
					High	Analog SIN/COS (500 mVpp), Digital Index (Ungated)
					Open	Analog SIN/COS (500 mVpp), Digital Index (Ungated)
26	High	Open ^a	Open ^a	Analog	Low	Analog SIN/COS (500 mVpp), Analog Index (1 Vpp)
				Ungated Digital	High	Analog SIN/COS (1 Vpp), Digital Index (Ungated)
				Analog	Open	Analog SIN/COS (1 Vpp), Analog Index (1 Vpp)
27	Open ^a	Open ^a	Open ^a	SPI Mode	Low	SPI Mode: Program Selection
					High	SPI Mode: Output Enabled
					Open	SSI 3W Mode ^b

a. Open selection must be connected to the middle of a voltage divider circuit (Figure 3).

b. SSI 3W mode is for monitoring purposes only.

Figure 3: Example of Voltage Divider Circuit

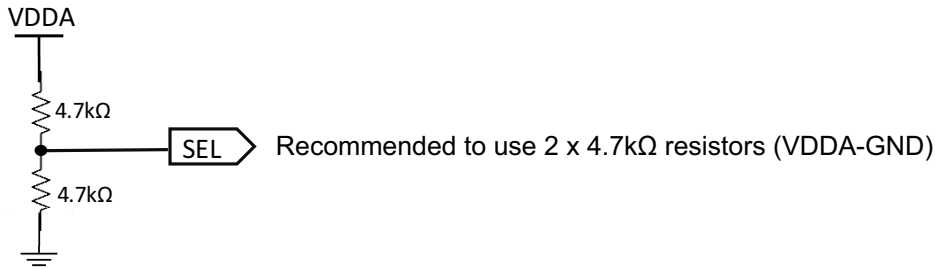

The preceding digital interpolation factor is used in conjunction with the following equations to cater to various rotational speed (RPM) and counts per revolution (CPR).

$$\text{RPM} = (\text{Count Frequency} \times 60) / \text{CPR}$$

The CPR (@ 1X interpolation) is based on the following equation, which is dependent on the radius of operation (R_{OP}).

$$\text{CPR} = \text{LPI} \times 2\pi \times R_{OP} \text{ (inch)} \text{ or } \text{CPR} = \text{LP mm} \times 2\pi \times R_{OP} \text{ (mm)}$$

NOTE: LP mm (lines per mm) = LPI / 25.4.

Programmable Interpolation Factor (Select Options)

The encoder is programmable by using SPI with an interpolation factor from 1X to 1024X.

1. Configure external selection to SPI Mode: Program Selection.
2. For signals output after configuration, set external selection to SPI Mode: Output Enabled.

SPI Communication Pinout (For Interpolation and Index Width Selection)

Table 2: Encoder Calibration Related Pinout

Pin	Name	Function
10	SPI_DOUT	SPI Data Output
2	SPI_DIN	SPI Data Input
17	SPI_CLK	SPI Clock

SPI Read and Write Timing Diagram (Maximum Clock Frequency 1 MHz)

Table 3: SPI Read and Write Memory Map

Bit	15	14	13	12	11	10	9	8	7	6	5	4	3	2	1	0
Read	0	Address[6:0]						Data[7:0]								
Write	1	Address[6:0]						Data[7:0]								

SPI Write

<Write Command = 1><7 bits address><8 bits data>

Figure 4: SPI Write Timing Diagram

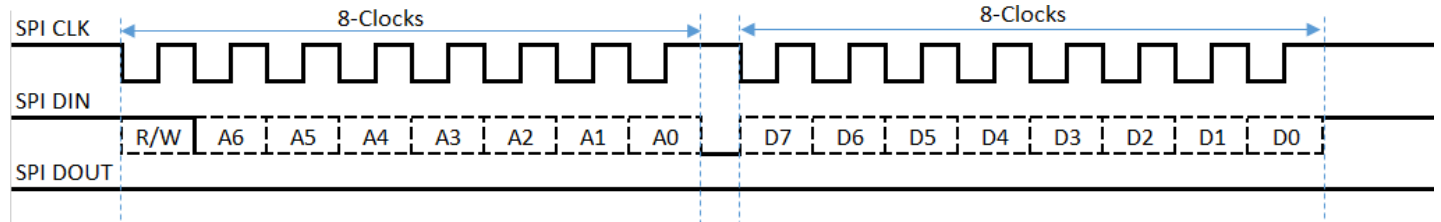

SPI Read

<Read Command = 0><7 bits address>

Figure 5: SPI Read Timing Diagram

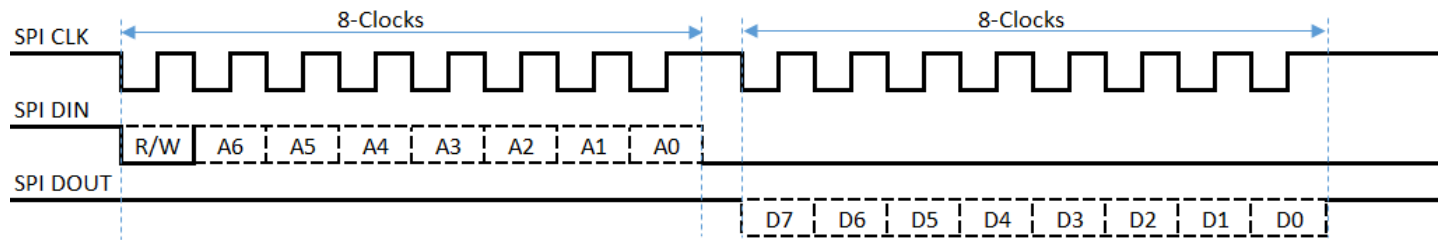

Unlock Sequence

1. Write to SPI address 0x10 with value AB (hex) to unlock Level 1.
2. Write to SPI address 0x14 with value 00 (hex) to go to Page 0.

Program Memory

1. Write to SPI address 0x11 with value A1 (hex) to program memory.

Interpolation Settings and Programming

1. Write to SPI address 0x0B and 0x0C with the desired value per the following table.
2. After finalizing the CPR settings, write to SPI address 0x11 (hex) with value A1 (hex) to program the AEDR-9940.

Byte Address	Page	Bit								Note
		7	6	5	4	3	2	1	0	
0x0B				lwidth_digital[1:0]		CPR[11:8]				CPR: 0–1024
0x0C		CPR[7:0]								

Table 4: List of Available Interpolation and Index Values in AEDR-9940

Interpolation CPR	0x0B (Hex)	0x0C (Hex)	lwidth_Digital	Index Width
1	Bit 0 = 0	01	00	90 deg
2	.	02	01	180 deg
.	.	.	10	270 deg
.	.	.	11	360 deg
10	.	0A		
11	.	0B		
.	.	.		
.	.	.		
255	Bit 0 = 0	FF		
256	Bit 0 = 1	00		
257	Bit 0 = 1	01		
.	.	.		
.	.	.		
512	Bit 1 = 1	00		
.	.	.		
.	.	.		
1024	Bit 2 = 1	00		

Recommended Setup for the Power Supply Pins and General Routing

Both the VDDA and VDD supplies, and the respective grounds (VSSA and VSSD) are to be connected separately as shown in [Figure 6](#). The following are the recommended schematic design rules to follow:

- Use a pair of 2.2- μ F and 0.1- μ F capacitors as a bypass on the VDD and VDDA traces. Place them in parallel as close as possible to the encoder ASIC package, in between the power and ground pins.
- Design separate VDD and VDDA traces.
- Minimize trace or cable length where possible.

Figure 6: Reference Schematic Diagram

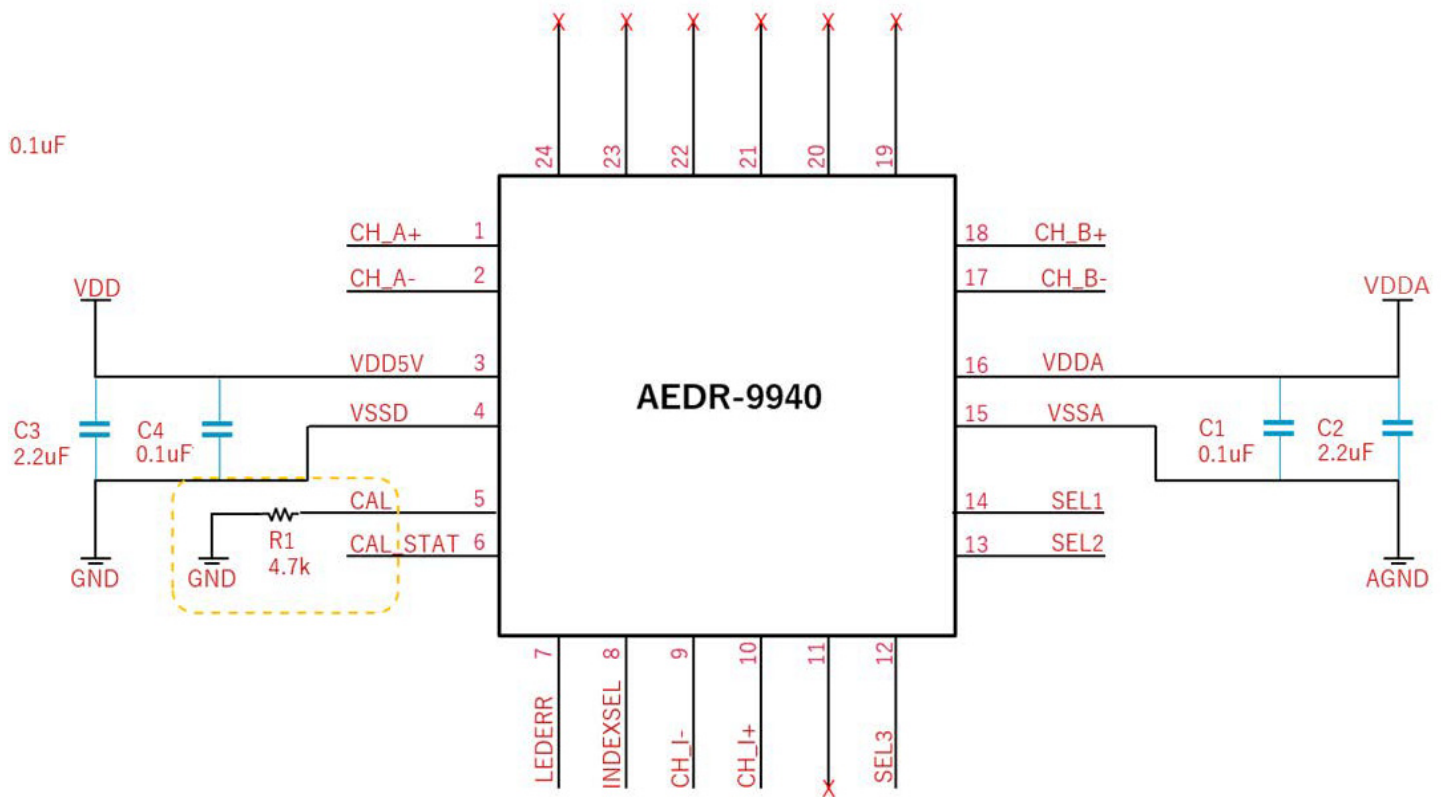
**NOTE:**

- See the [Select Options – AEDR-9940 Built-in Interpolation Factor](#) table for SEL1, SEL2, SEL3, and INDEXSEL.
- VDDA and VDD must be same voltage level.
- VSSA and VSS must be connected together.
- The LEDERR and CAL_STAT pins are encoder status output. Do not use the output to directly drive the LED. If not used, leave the pins unconnected.
- Place a weak pull-low onto the CAL pin, for example, a 4.7-k Ω resistor.

Auto Calibration Process

Auto Calibration Steps (Off-Scale to On-Scale Trigger)

The AEDR-9940 has a built-in auto calibration algorithm that can be triggered by moving the encoder from an off-scale condition (no window bar) to an on-scale condition (window bar). Alternatively, use a paper or an opaque material and place it in front of the encoder and remove it to trigger the auto calibration process. The purpose of the calibration process is to align the center of the Index signal to the center of the Channel B signal. The misalignment of the Index signal is due to potential spatial misalignment of the encoder to the code strip after assembly.

1. Ensure the encoder is not positioned over the code strip or the window-bar pattern (off-scale). Power on the encoder. Alternatively, place a piece of opaque (not transparent) material in front of the encoder and then remove it.
2. Move the encoder PCBA/read head so that it is positioned over the code strip and within the specified spatial tolerance (on-scale).
3. Move the encoder PCBA/read head back and forth over the code strip. Monitor the calibration status by observing the CAL_Stat signal or Channel A+/Channel B+.
4. Move the encoder PCBA/read head continuously for at least 5 seconds to 10 seconds; the total calibration time is dependent on both the speed of movement and the counts of the index pattern crossing the encoder ASIC. The Channel B+ state will change to high if the auto calibration process is successful. The states of both Channel A+ and Channel B+ will change to high if the auto calibration process is unsuccessful. If auto calibration is unsuccessful, verify the gap between the encoder and the code strip is correct, and repeat steps 1 to 4 as needed.
5. Perform a power cycle and the encoder ASIC will function as normal.

NOTE:

- After calibration is completed, a power cycle is required for the new encoder settings to be effective.
- AEDR-9940ER option is without this off-scale to on-scale trigger feature.

Auto Calibration Steps (By Pin Trigger)

1. Spin the motor at a rotation speed between 1000 and 2000 rpm.
2. Short the CAL pad to the VDDA or VDD line. Use a high-value resistor such as 4.7 kΩ or 5.6 kΩ to do the shorting.
3. Turn on power to the encoder. This will trigger the ASIC to start the auto calibration process.
4. Wait for at least 5 seconds. Observe the CAL_STAT pin, which will start pulsing as the calibration begins. Once the calibration is completed, CAL_STAT will remain high. CAL_STAT will remain pulsing if the calibration attempt fails.
5. Remove the short between CAL to VDDA or VDD. Perform a power cycle, and the encoder ASIC will function as normal.

Pad	CAL (pin5)	A+	B+	I+	Status
Pad State	H	L	L	L	Calibrating
	H	H	L	L	Incremental calibration done
	H	L	H	L	Incremental and index calibration done
	H	H	H	L	Calibration error

LED Status (LED Pins)

Pad	CAL_STAT	LEDERR	Status
Pad State	Pulsing (500 ms)	L	Calibrating
	H	L	Calibration done
	L	H	Out of tangential/radial alignment

Status Pin States (LED Indicators)

PINS	Power Up from t = 0	Encoder Ready	Calibrating	Calibration Done	Calibration Error	LEDERROR ^a	LEDERROR ^b
CAL_STAT	L	L	Pulsing (500 ms)	H	L	L	L
LEDERR	L	L	L	L	L	H	Pulsing (500 ms)

a. No toggling signal indicates the maximum LED current state. (Off-scale/No Window Bar)

b. Early warning on high LED current, but signal is normal.

Digital Signal Characteristics (Code Wheel of R_{OP} @ 12.73 mm, 625 CPR)

Table 5: Typical Channel A and Channel B Signal Dynamic Performance over Different Interpolation Values

Parameter	Symbol	Dynamic Performance								Unit
		Typical								
		1X	2X	4X	8X	16X	32X	64X	128X	
Cycle Error	ΔC	± 3	± 4	± 5	± 9	± 11	± 19	± 19	± 19	$^{\circ}e$
Pulse Width (Duty) Error	ΔP	± 3	± 3	± 5	± 8	± 10	± 16	± 16	± 16	$^{\circ}e$
Phase Error	$\Delta \phi$	± 1	± 2	± 3	± 5	± 6	± 9	± 9	± 9	$^{\circ}e$
State Error	ΔS	± 2	± 3	± 5	± 7	± 7	± 18	± 18	± 18	$^{\circ}e$
Index Pulse Width (Gated 90°)	Po	90								$^{\circ}e$
Index Pulse Width (Gated 180°)	Po	180								$^{\circ}e$
Index Pulse Width (Gated 360°)	Po	N/A	360							$^{\circ}e$
Index Pulse Width (Raw Ungated)	Po	330	N/A							$^{\circ}e$

NOTE:

- Typical values represent the average value of encoder performance based on factory setup conditions at the maximum output frequency for each interpolation.
- The optimal performance of the encoder depends on the motor and system setup condition of the individual customer.

Electrical Characteristics

Characteristics over recommended operating conditions at 25°C.

Table 6: Typical Channel A and Channel B Signal Electrical Characteristics

Parameter	Symbol	Min.	Typ.	Max.	Unit	Notes
High Level Output Voltage	VOH	2.4	—	—	V	IOH = -20 mA
Low Level Output Voltage	VOL	—	—	0.4	V	IOH = +20 mA
Output Current per Channel, I _{out}	I _o	—	—	20	mA	—
Rise Time	t _r	—	<50	—	ns	CL ≤ 50 pF
Fall Time	t _f	—	<50	—	ns	

Code Wheel Characteristics

Characteristics are based on a Broadcom-qualified code wheel supplier. Contact Broadcom for information regarding qualified reflective code wheel suppliers.

Table 7: Code Wheel Characteristics

Parameter	Symbol	Min.	Typ.	Max.	Unit	Notes
Specular Reflectance	R_f	60%	—	—	—	Reflective area
		—	—	5%	—	Non-reflective area
LED Peak Wavelength	λ_p	—	660	—	nm	—

Code Wheel Design Guideline

The window tracks are reflective surfaces, and the bar tracks are opaque surfaces.

The Incremental window/bar tracks are trapezoid. The number of Incremental window/bar tracks depends on the CPR; and the Incremental windows/bars have the same width value.

There is an offset between the Incremental window tracks and the Index window track, denoted by F.

The Index window track is rectangular. There is only one Index window track, and its width is 0.04988 mm.

Figure 7: Code Wheel Design Guideline (Not to Scale)

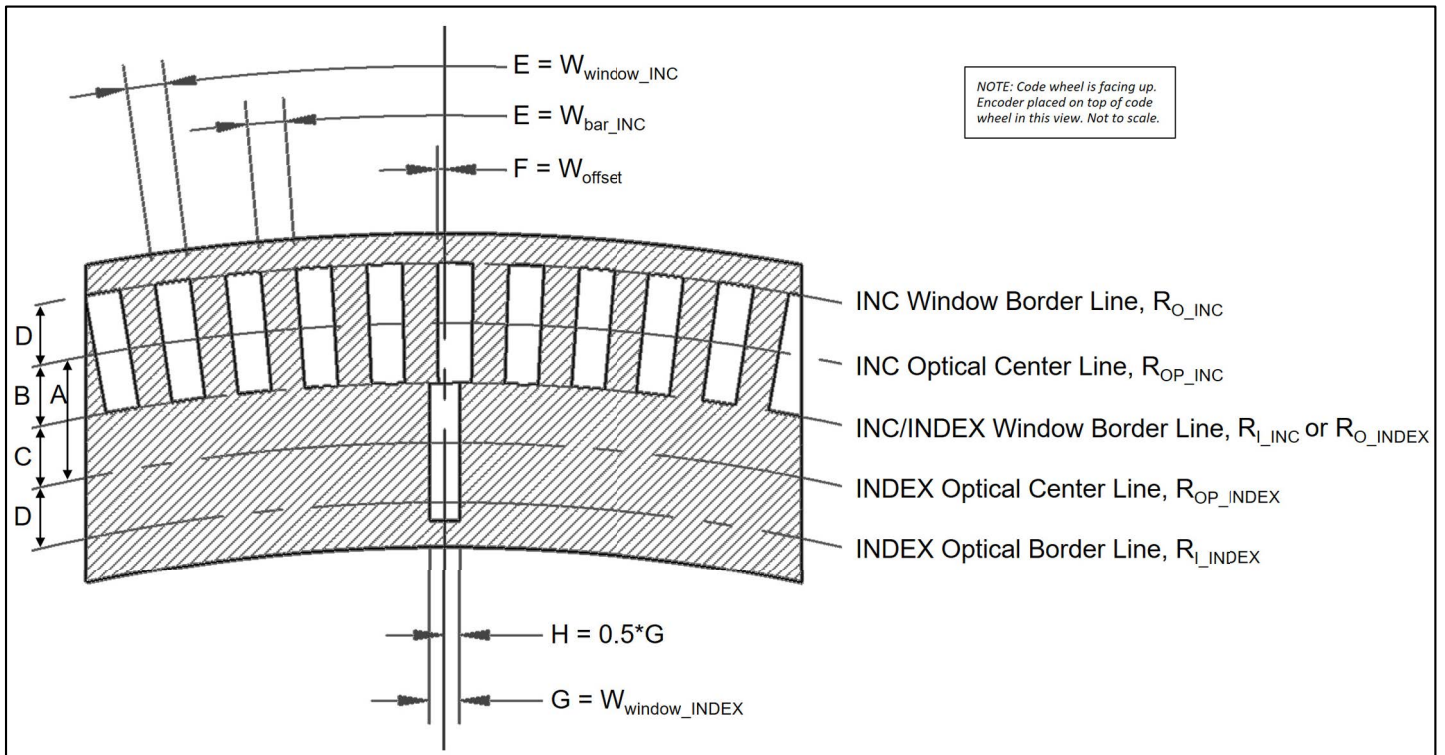

Dimension	Formula	AEDR-9940
Pitch (°)	(360/CPR)	—
A (mm)	$R_{OP_INC} - R_{OP_INDEX}$	1.1504
B (mm)	$R_{OP_INC} - R_{I_INC}$	0.5752
C (mm)	$R_{O_INDEX} - R_{OP_INDEX}$	0.5752
D (mm)	$R_{O_INC} - R_{OP_INC}$ or $R_{OP_INDEX} - R_{I_INDEX}$	0.6000
E (°)	(360/CPR)/2	—
F (°)	$0.25 * E$	—
G (mm)	—	0.04988
H (mm)	$G / 2$	0.02494

Code Wheel Design Example

The following demonstrates a code wheel design for 198 LPI @ 625 CPR.

Determine R_{OP_INC} ;	$(25.4 / 198.4375) * (625 / 2\pi)$	≈ 12.7324 mm
Determine R_{OP_INDEX} ;	$12.7324 - 1.1504$	$= 11.5820$ mm
Determine R_{O_INC} ;	$12.7324 + 0.60$	$= 13.3324$ mm
Determine R_{I_INC} ;	$12.7324 - (0.5752)$	$= 12.1572$ mm
Determine R_{O_INDEX} ;	$11.5820 + (0.5752)$	$= 12.1572$ mm
Determine R_{I_INDEX} ;	$11.5820 - 0.60$	$= 10.9820$ mm
Determine W_{window} & W_{bar} ;	$(360 / 625) / 2$	$= 0.288^\circ$
Determine W_{offset} ;	$0.25 * 0.288$	$= 0.072^\circ$

Code Strip Design Guideline

The Incremental/Index window track is a reflective surface, and the Incremental bar track is opaque.

The window width is denoted by W_{window} , and the bar width is denoted by W_{bar} .

All windows and bars has the same width value, E.

There is an offset between the Incremental window track and the Index window track, denoted by F.

Figure 8: Code Strip Design Guideline (Not to Scale)

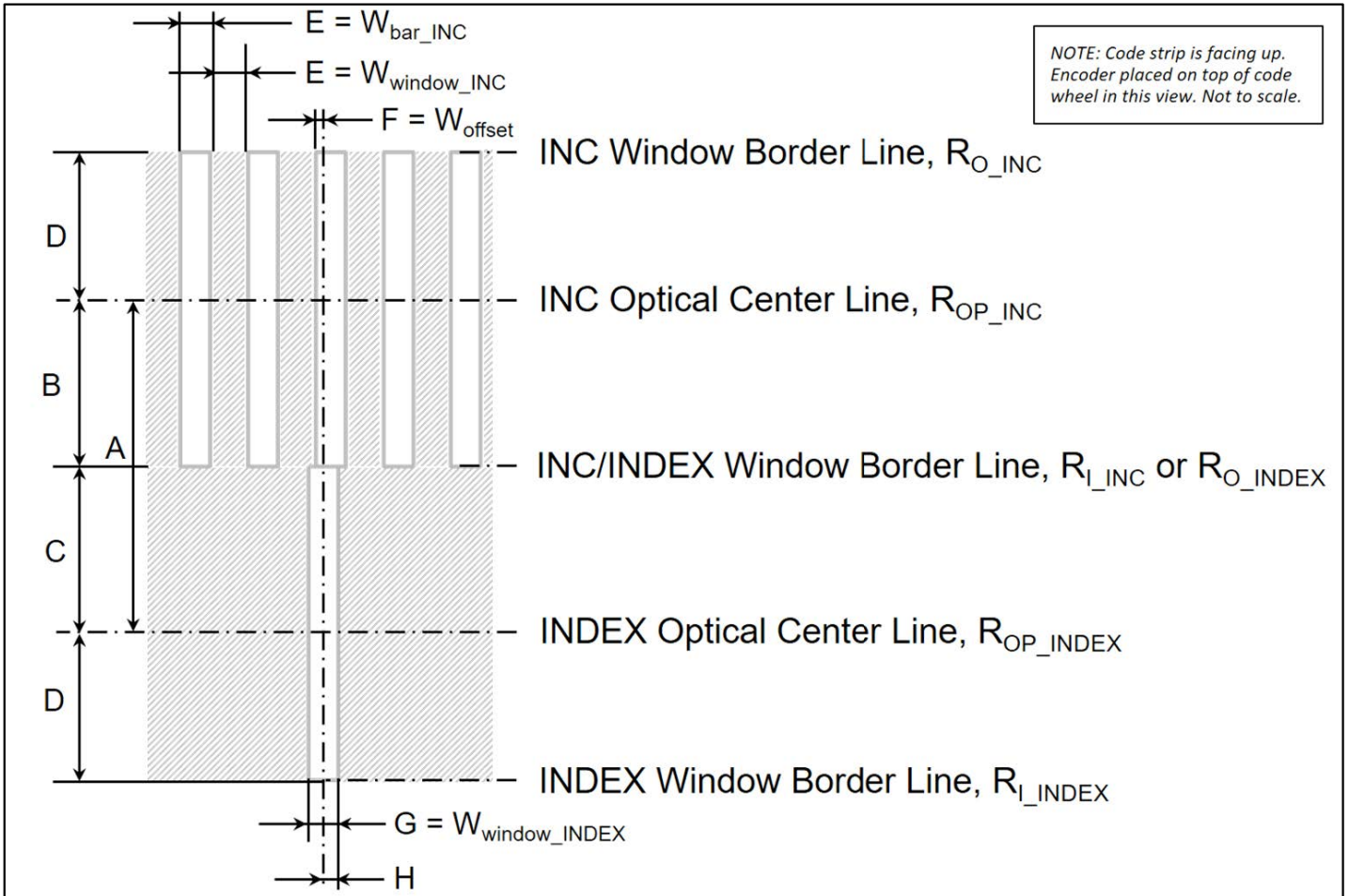

Dimension	Formula	AEDR-9940
Pitch (mm)	$25.4 / \text{LPI}$	0.1280
A (mm)	$R_{\text{OP_INC}} - R_{\text{OP_INDEX}}$	1.1504
B (mm)	$R_{\text{OP_INC}} - R_{\text{I_INC}}$	0.5752
C (mm)	$R_{\text{O_INDEX}} - R_{\text{OP_INDEX}}$	0.5752
D (mm)	$R_{\text{O_INC}} - R_{\text{OP_INC}}$ or $R_{\text{OP_INDEX}} - R_{\text{I_INDEX}}$	0.6000
E (mm)	$\text{Pitch} / 2$	0.0640
F (mm)	$0.25 * E$	0.0160
G (mm)	—	0.04988
H (mm)	$G / 2$	0.02494

Multiple Index Pulse Code Strip Design Guideline

Multiple Index pulses can be designed into the code wheel or code strip for pseudo absolute encoder application.

The code wheel and code strip design is governed by the design guidelines shared on the previous pages.

The Index pitch must be a multiplier of the Incremental pitch. The multiplier must be an integer that is greater than or equal to N; see [Table 8](#).

Figure 9: Code Wheel Design Guideline for Pseudo Absolute Encoder Application (Not to Scale)

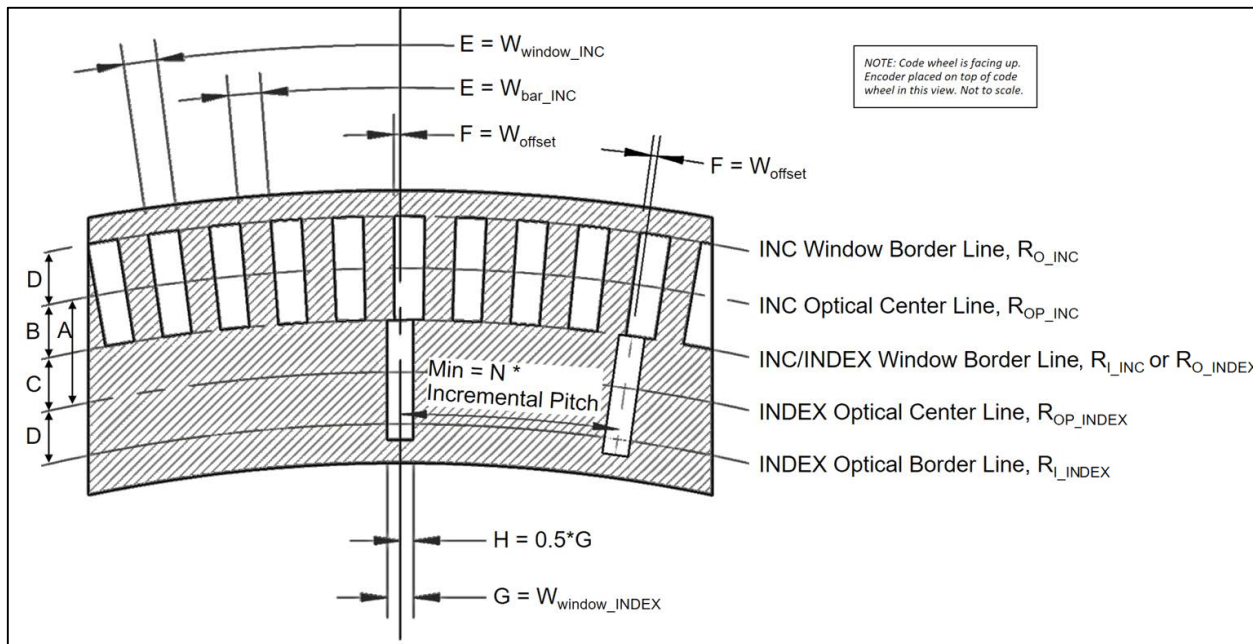

Figure 10: Code Strip Design Guideline for Pseudo Absolute Encoder Application (Not to Scale)

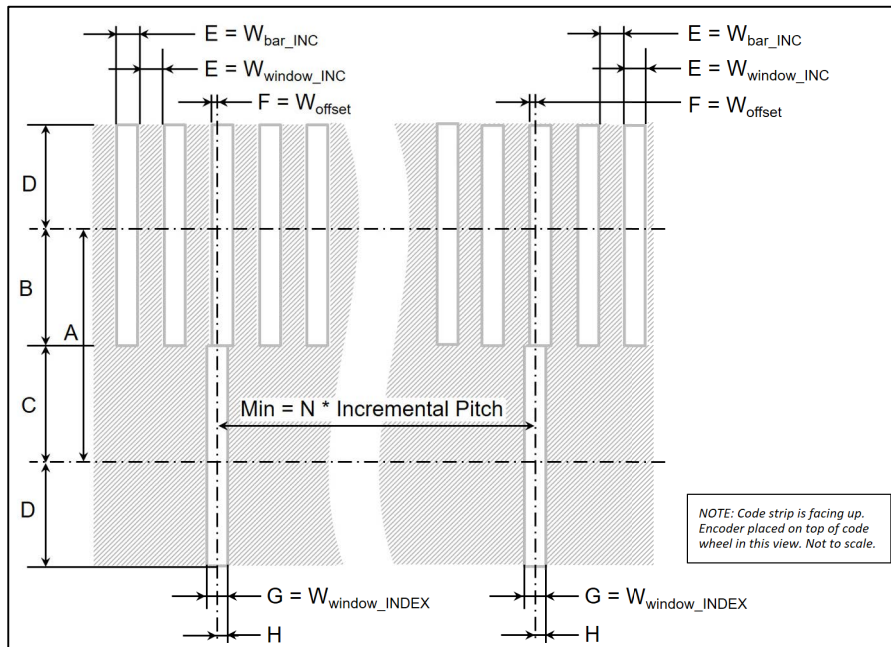
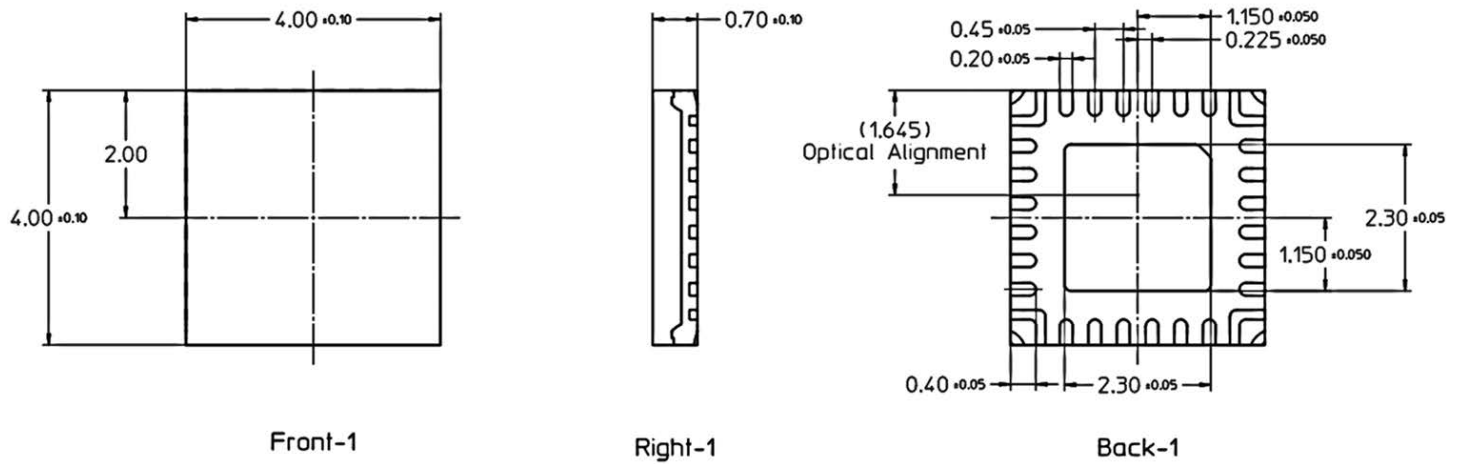

Table 8: Multiplier for Index Pitch in Pseudo Absolute Encoder Application

Application	Integer N
Linear application	4
Rotary application, $CPR \geq 512$	4
Rotary application, $200 \leq CPR < 512$	5
Rotary application, $128 \leq CPR < 200$	6

Package Outline Drawing

Figure 11: Package Outline



Recommended PCB Land Pattern

Figure 12: Recommended PCB Land Pattern

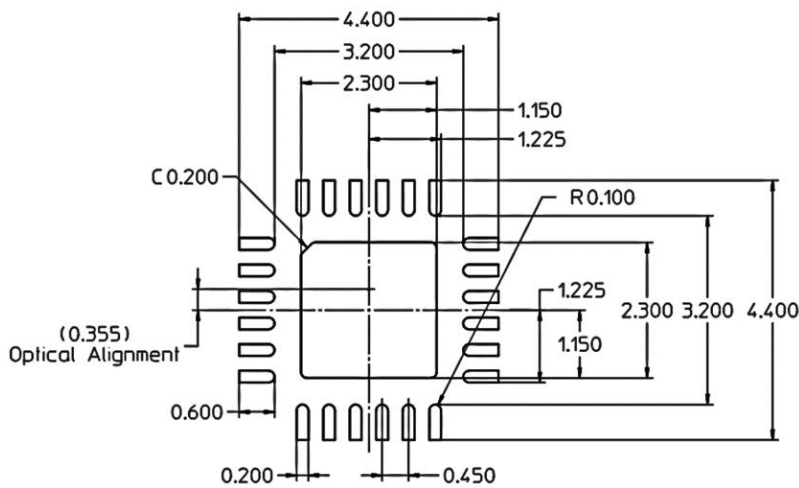

All dimensions in mm.

Tolerance: $x.xx \pm 0.05$ mm.

Encoder Placement Orientation, Position, and Direction of Movement

The AEDR-9940 is designed with both the emitter and the detector dice placed in parallel to the code wheel window/bar orientation. The encoder package is mounted on top facing down onto the code wheel. When properly aligned, the emitter sits in the middle of the Incremental track and Index track.

The optical center of the encoder package must be aligned tangential to the code wheel's R_{OP} . The optimal gap setting recommended is 1.35 mm, with the range of 0.85 mm to 2.35 mm (based on 625 CPR).

Channel A leads Channel B when the code wheel rotates counterclockwise and vice versa.

Figure 13: Encoder Axial Gap

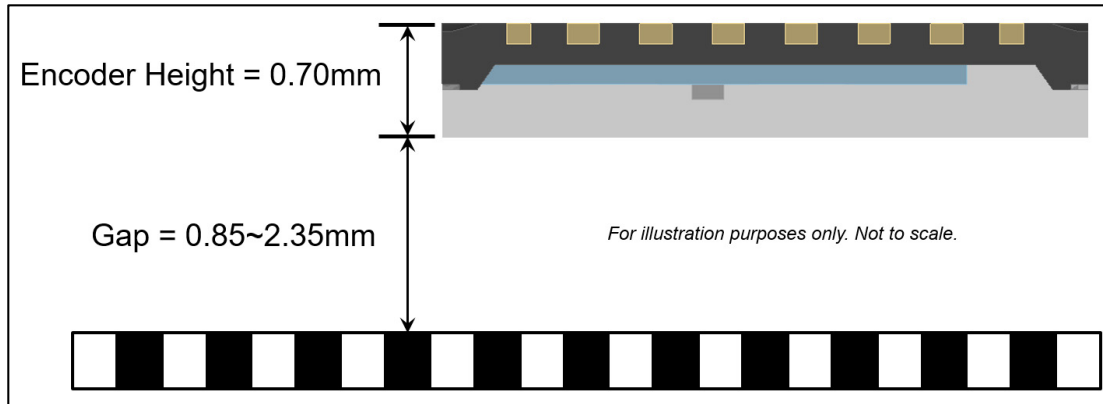

Figure 14: Top View of AEDR-9940 with Respect to Code Wheel Positioning

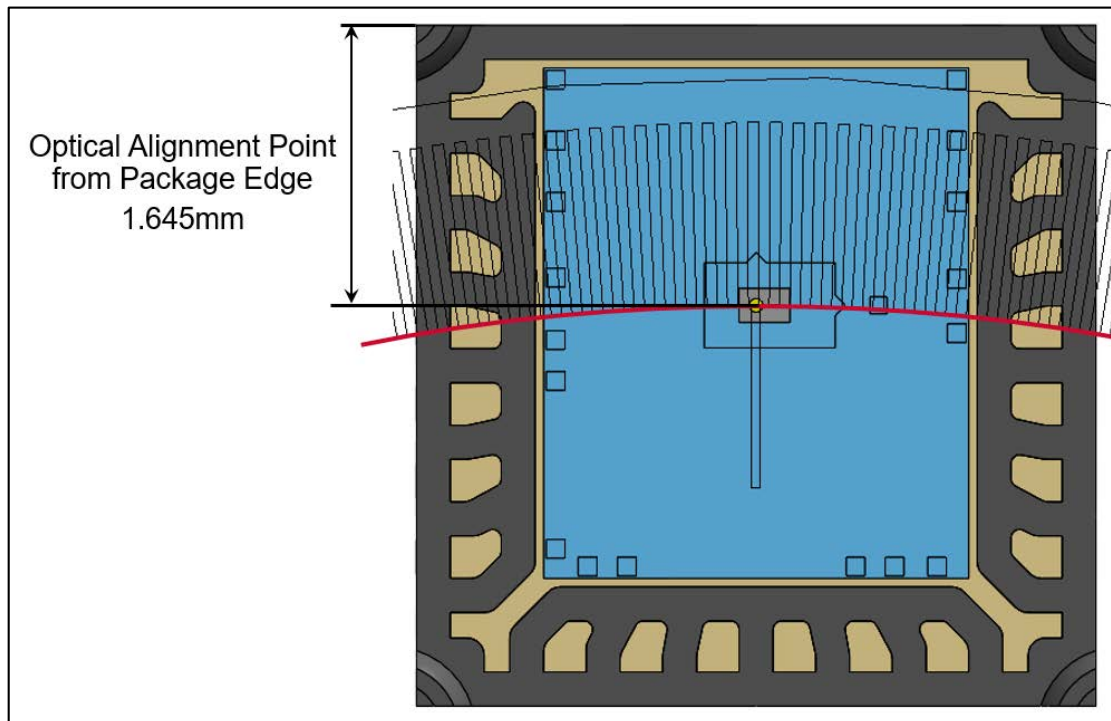
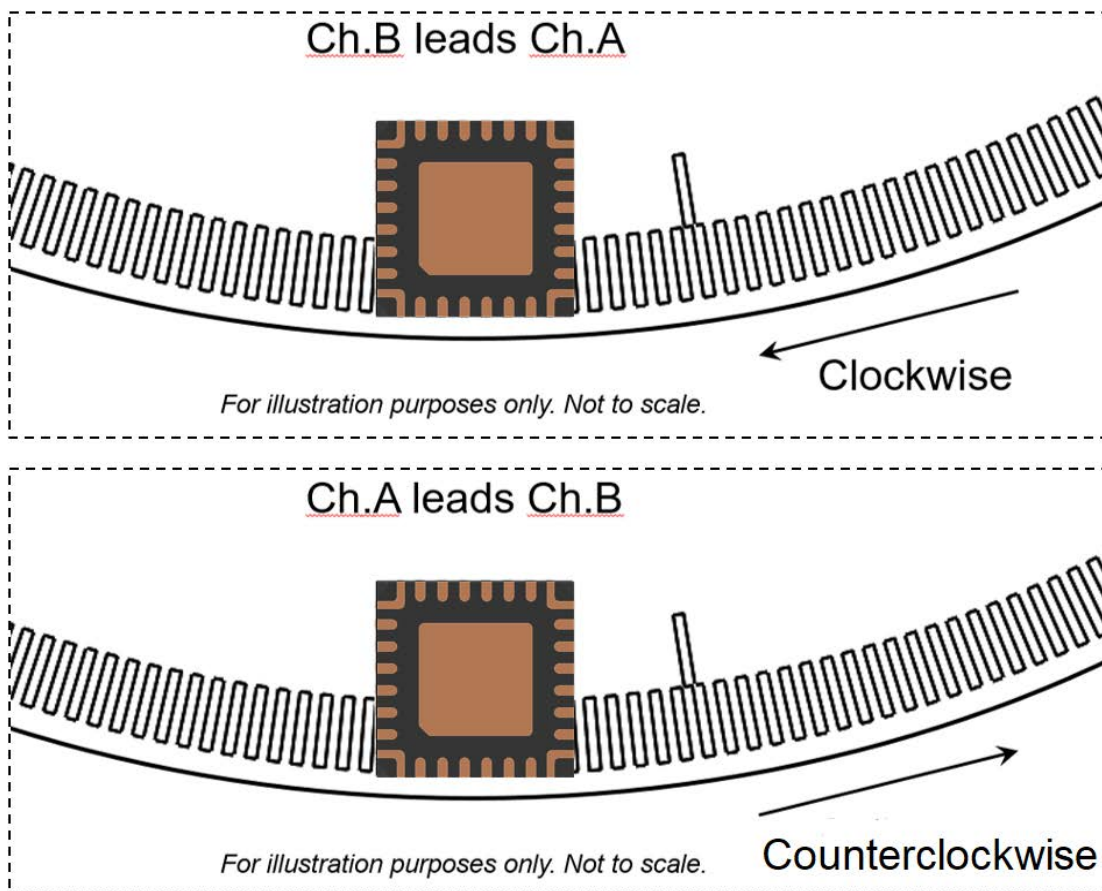

Figure 15: Channel A and Channel B Signal Output Sequence Is with Respect to Code Wheel Rotational Direction

Moisture Sensitivity Level

The AEDR-9940 package is qualified for Moisture Sensitive Level 3 (MSL 3). Precaution is required to handle this moisture sensitive product to ensure the reliability of the product.

Storage before Use

- An unopen moisture barrier bag (MBB) can be stored at <math><40^{\circ}\text{C}/90\% \text{ RH}</math> for 12 months.
- Recommended to open the MBB just prior to assembly.

Control after Opening the MBB

- The encoder ASIC, which will be subjected to SMT reflow, must be mounted within 168 hours of factory conditions of <math><30^{\circ}\text{C}/60\% \text{ RH}</math>.

Control for Unfinished Reel

- Stored and sealed MBB with desiccant or desiccators at <math><5\% \text{ RH}</math> condition.

Baking Is Required If:

- The humidity indicator card (HIC) is >10% when read at $23 \pm 5^{\circ}\text{C}$.
- The encoder floor life exceeds 168 hours after opening the moisture barrier bag.
- Recommended baking condition: $60 \pm 5^{\circ}\text{C}$ for 20 hours (in tape and reel) or $125 \pm 5^{\circ}\text{C}$ for 8 hours (loose units).

Recommended Lead-Free Solder Reflow Soldering Temperature Profile

Figure 16: Typical Lead-Free Solder Reflow Profile

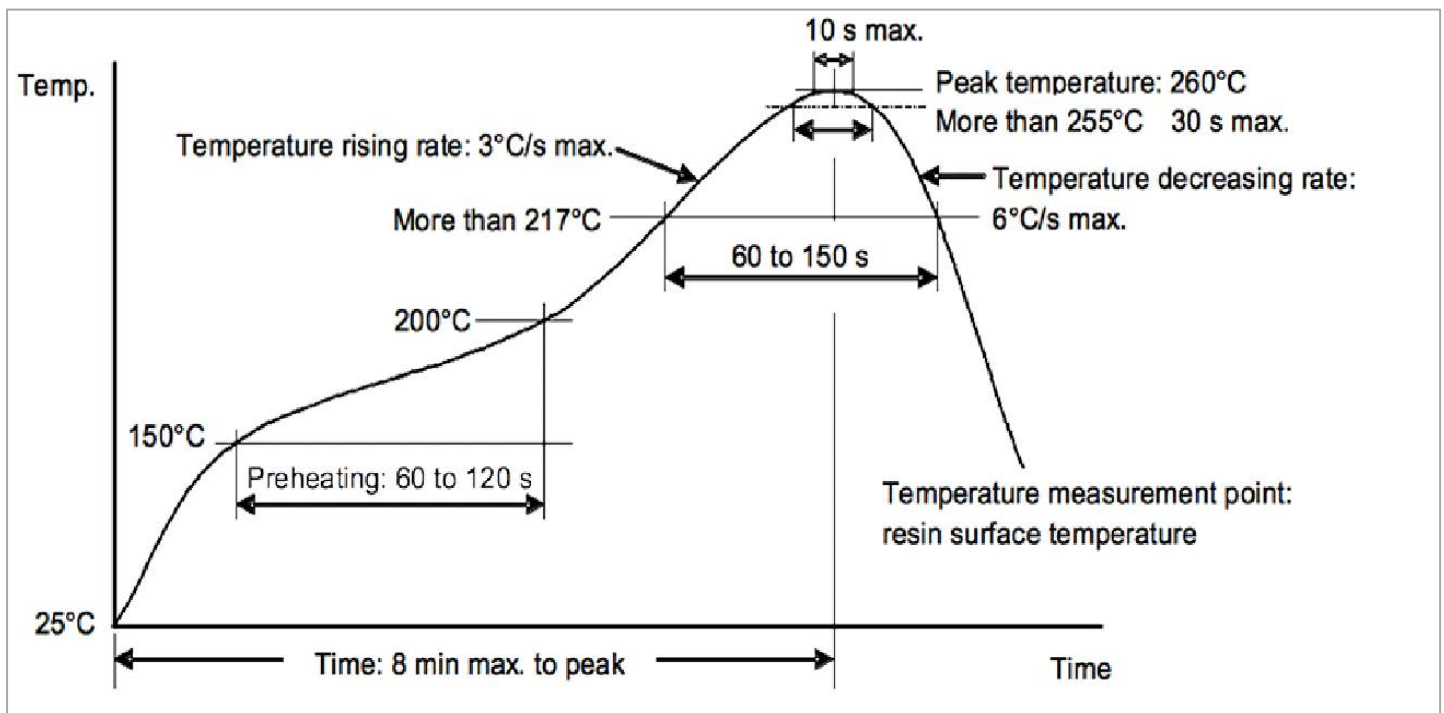

NOTE: Be careful when handling the encoder ASIC because it is a sensitive optical device.

Tape and Reel Information

Figure 17: Tape and Reel Feeding Direction

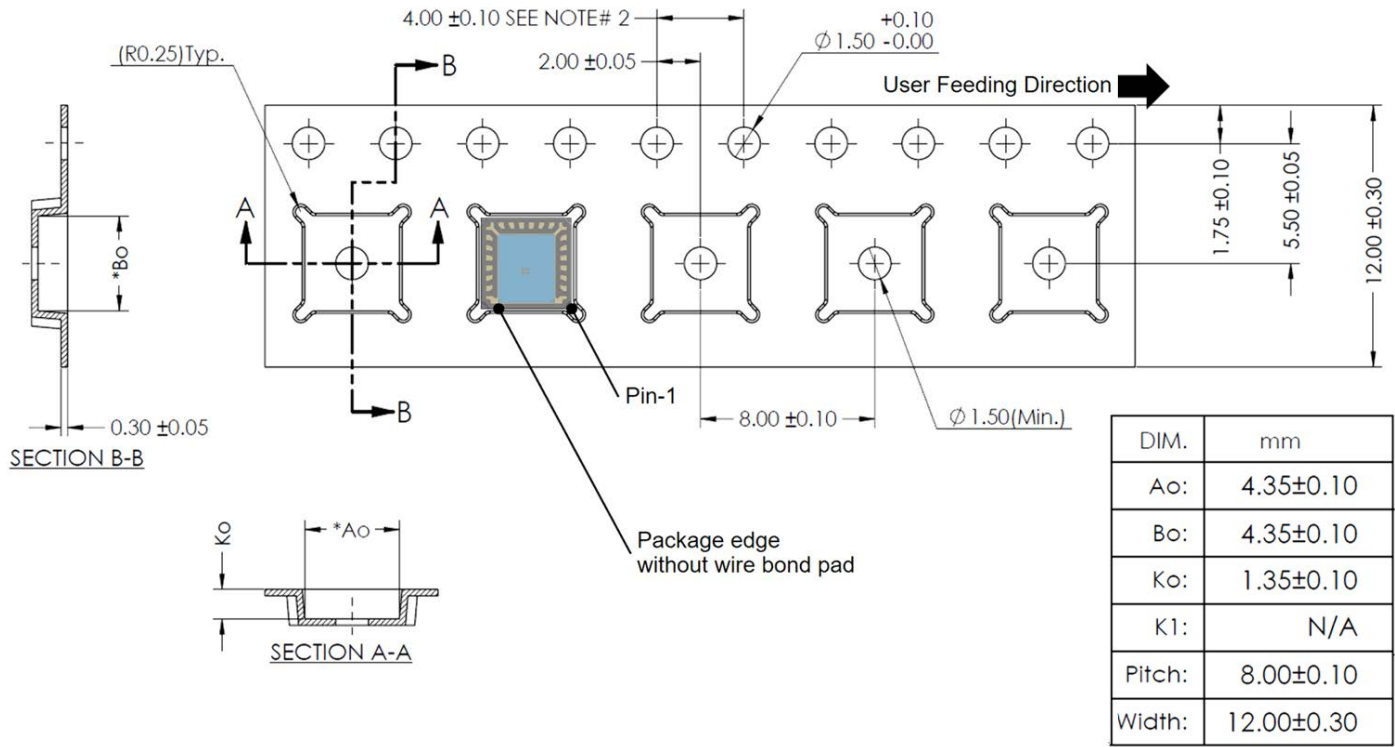
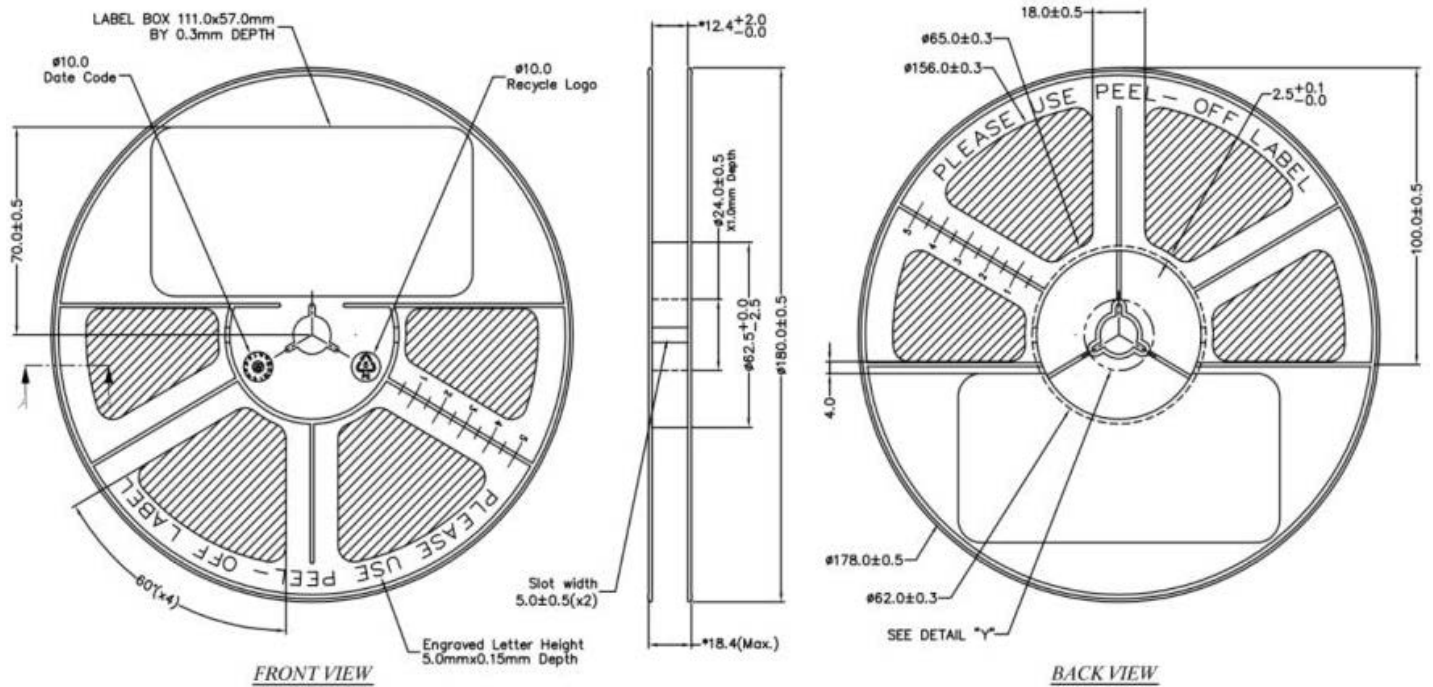

Figure 18: Carrier Tape Dimensions



Ordering Information

A E D R - 9 9 4 0 - 1 0 X

4	Resolution = 198.4 LPI
X	Packaging 0 = 1000 pieces 2 = 100 pieces

NOTE: Select part number AEDR-9940ER if the application does not need the off-scale to on-scale auto calibration feature.

Part Number	Description
AEDR-9940-100	198.4 LPI Rotary Incremental Encoder, 1000 pieces
AEDR-9940-102	198.4 LPI Rotary Incremental Encoder, 100 pieces
HEDS-9940EVB	AEDR-9940 evaluation board with 2 units of code wheel, multiple optical radius 256, 400, 512, 720 CPR base
HEDS-9940EVB1	AEDR-9940 evaluation board with 2 units of code wheel, multiple optical radius 200, 360, 500, 625 CPR base
HEDS-9940EVBL	AEDR-9940 evaluation board with 2 units of code strip, 128 μ m
HEDS-9940PRGEVB1	SPI programming kit with evaluation board bundling with 2 units of code wheel, multiple optical radius 200, 360, 500, 625 CPR base
HEDS-9940PRGEVB	SPI programming kit with evaluation board bundling, 2 units of code wheel. multiple optical radius 256, 400, 512, 720 CPR base
HEDS-9940PRGEVBL	SPI programming kit with evaluation board bundling, 2 units of code strip 128 μ m
AEDR-9940ER-100	198.4 LPI Incremental Encoder, no auto calibration, 1000 pieces
AEDR-9940ER-102	198.4 LPI Incremental Encoder, no auto calibration, 100 pieces
HEDS-9940EREVB	AEDR-9940ER evaluation board with 2 units of code wheel, multiple optical radius 200, 360, 500, 625 CPR base
HEDS-9940ER1EVB	AEDR-9940ER evaluation board with 2 units of code wheel, multiple optical radius 256, 400, 512, 720 CPR base
HEDS-9940ERLEVB	AEDR-9940ER evaluation board with 2 units of code strip, 128 μ m

Copyright © 2024–2026 Broadcom. All Rights Reserved. The term “Broadcom” refers to Broadcom Inc. and/or its subsidiaries. For more information, go to www.broadcom.com. All trademarks, trade names, service marks, and logos referenced herein belong to their respective companies.

Broadcom reserves the right to make changes without further notice to any products or data herein to improve reliability, function, or design. Information furnished by Broadcom is believed to be accurate and reliable. However, Broadcom does not assume any liability arising out of the application or use of this information, nor the application or use of any product or circuit described herein, neither does it convey any license under its patent rights nor the rights of others.