

Reducing EMI from an Internally Clocked Sigma-Delta Modulator Through Spread Spectrum

By Lim Shiun Pin, Technical Marketing Engineer, Isolation Products Division, Broadcom Inc.

Over the past two decades, shunt-based current-sensing technology using the Broadcom[®] optically isolated sigma-delta modulator has gained wide acceptance with industrial general inverters and servo drives over traditional current transformers (CTs) and hall effect sensors (HESs). In addition to small size and low cost advantages, various current sensing ranges can be easily realized by choosing an appropriate shunt resistance value and connecting to the sigma-delta modulator. This combined solution provides superior performance in terms of accuracy, linearity, input offset over temperature, and signal-to-noise (SNR) ratio while reinforced galvanic isolation is put in place using Broadcom's proven optical isolation technology.

Input signal information is contained in the modulator output's single-bit data stream, randomized, and represented by the density of ones and zeros¹. A Sinc digital filter (implemented in ASIC, FPGA, or the microcontroller) converts the single-bit data stream from the modulator into a 16-bit output word similar to the digital output of a conventional A/D converter.

The sigma-delta modulator and the digital filter are then synchronized by a reference clock with a frequency normally centered at 10 MHz or 20 MHz. Depending on the configuration of the sigma-delta modulator, the single clock signal is either generated from within the sigma-delta modulator or provided by the board system clock.

Printed circuit board (PCB) trace routing between the sigma-delta modulator, digital filter, and the single clock signal source can sometimes be as long as 30 cm. PCB traces that carry such a high-frequency clock signal may cause unwanted electromagnetic interference (EMI) noise to other devices placed in close proximity. The higher the frequency, the more efficiently the PCB traces become an EMI-radiating antenna.

To prove this point, a receiver loop antenna is placed on the PCB trace where a 10-MHz clock signal is routed from a function generator to an externally clocked-in sigma-delta modulator (as shown in [Figure 1](#)). The frequency spectrum is then captured using a spectrum analyzer sweeping from 1 MHz to 100 MHz.

Frequency peaks occur at 10 MHz while harmonics of the clock signal occur at 30 MHz and 50 MHz (see [Figure 2](#)). The scope capture in [Figure 2](#) (probed at the clock-in pin) shows that clock jitter is small, spreading about 200 kHz.

1. *ACPL-C797 Optically Isolated Sigma-Delta Modulator*, AV02-2581EN Data Sheet, November 18, 2013.

Figure 1: A Receiver Loop Antenna is Placed on the PCB Trace Where a Single Clock Signal Is Routed to an Externally Clocked Sigma-Delta Modulator and Digital Filter

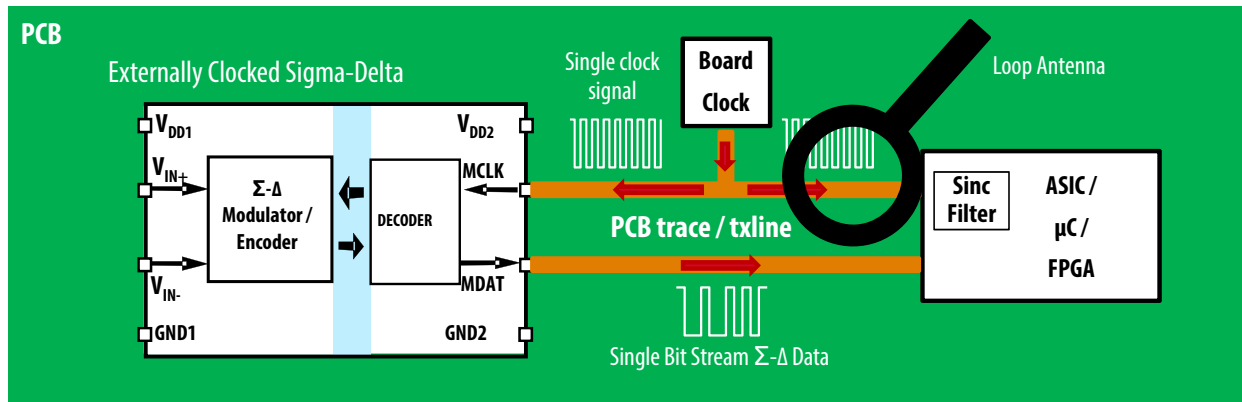
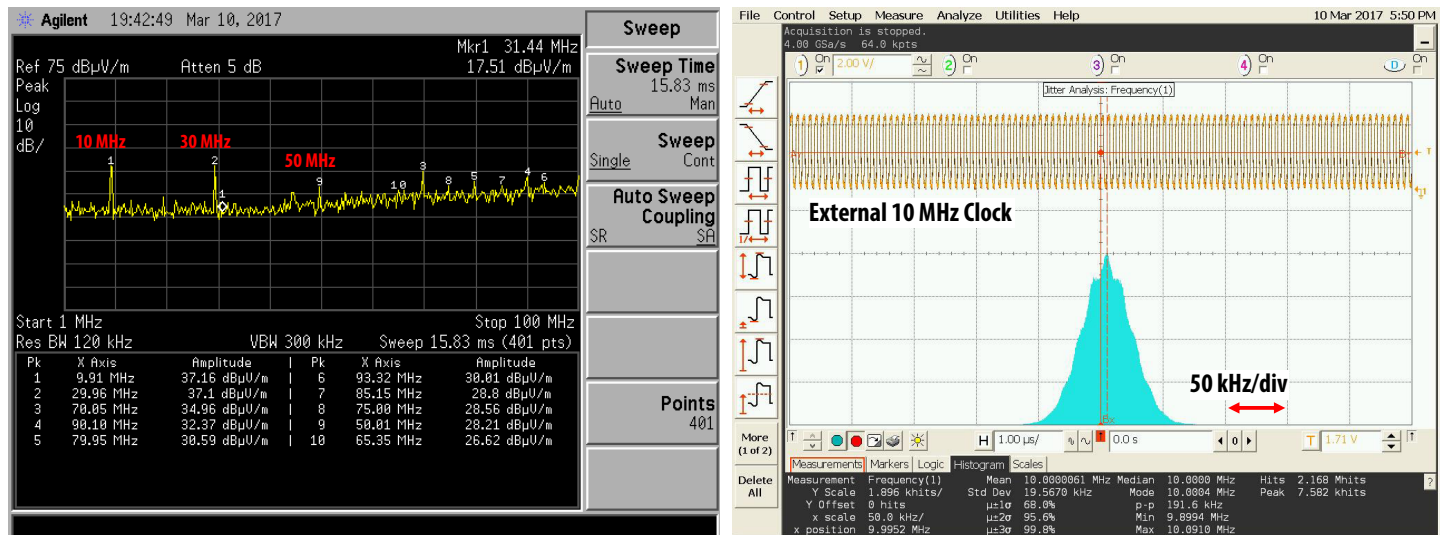

Figure 2: Frequency Spectrum Measured from PCB traces (left) and Clock Jitter Measurement (right) (Probed at the Clock-in Pin of an Externally Clocked Sigma-Delta Modulator)



Broadcom’s internally clocked sigma-delta modulators, like the ACPL-C797, employ a single clock for sigma-delta modulation and demodulation. To reduce EMI radiations, a spread-spectrum technique is applied. Using a similar setup without the function generator, as shown in Figure 3, the 10-MHz clock signal and its harmonics are not observed from the frequency spectrum captured in Figure 4. The clock frequency spread is about 800 kHz.

Figure 3: Receiver Loop Antenna Placed on the PCB Trace Where Single Clock Signal from an Internally Clocked Sigma-Delta Modulator Is Routed to the Digital Filter

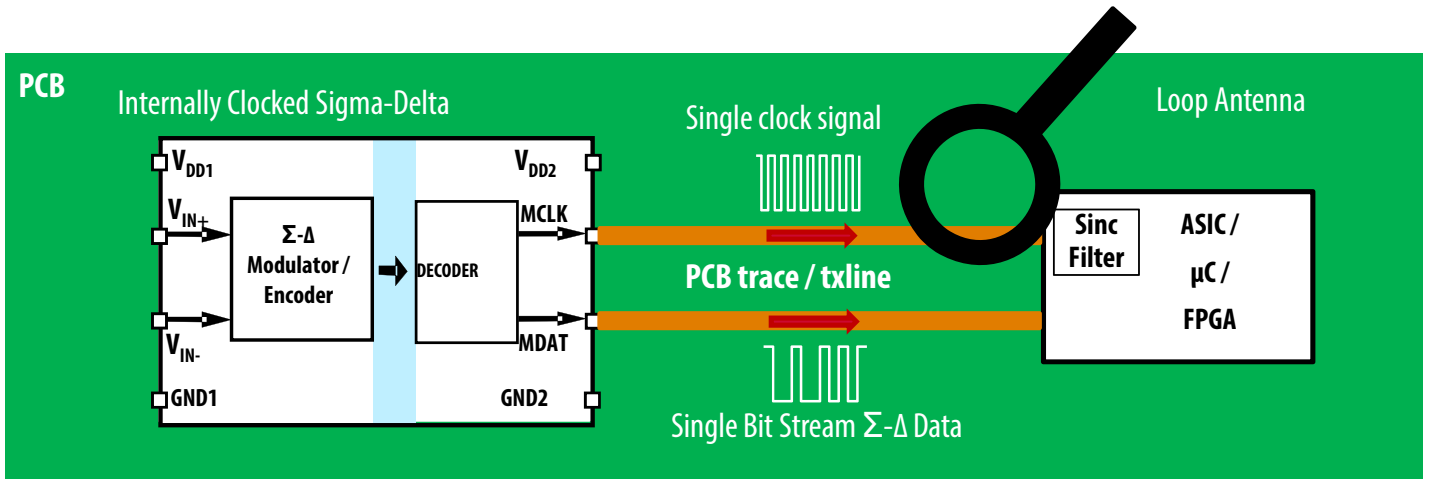
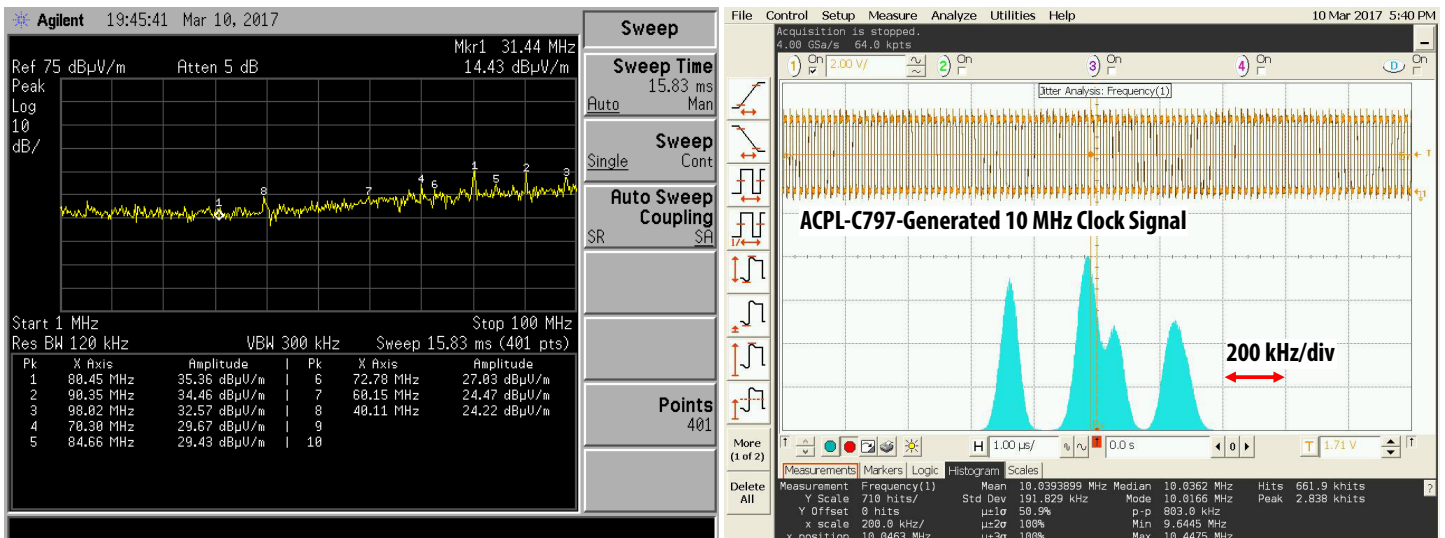

Figure 4: Frequency Spectrum of the 10-MHz Clock Signal from ACPL-C797 Measured from the PCB Traces (left) and Clock Jitter Measurement (right)



Broadcom, the pulse logo, Connecting everything, Avago Technologies, Avago, and the A logo are among the trademarks of Broadcom and/or its affiliates in the United States, certain other countries, and/or the EU.

Copyright © 2017–2020 Broadcom. All Rights Reserved.

The term “Broadcom” refers to Broadcom Inc. and/or its subsidiaries. For more information, please visit www.broadcom.com.

Broadcom reserves the right to make changes without further notice to any products or data herein to improve reliability, function, or design. Information furnished by Broadcom is believed to be accurate and reliable. However, Broadcom does not assume any liability arising out of the application or use of this information, nor the application or use of any product or circuit described herein, neither does it convey any license under its patent rights nor the rights of others.

