

BCM957508-N2100G

Dual-Port 100 Gb/s Ethernet PCI Express 4.0 x16 OCP 3.0 SFF Network Adapter

General Description

The Broadcom[®] BCM957508-N2100G is a dual-port 100 Gb/s PCI Express 4.0 x16 Network Adapter designed to the Open Compute Project (OCP) 3.0 Design Specification in small form factor with two QSFP56 network connectors. The adapter supports QSFP56/QSFP28/QSFP+ optical modules and copper direct-attach cables. The network adapter uses the Broadcom BCM57508 200GbE MAC controller with an integrated dual-channel 100GbE SFI transceiver.

Features

- Dual-port pluggable media interface, which is compatible with a QSFP56/QSFP28/QSFP+ optical transceiver or a copper direct-attach cable.
- Industry's most secure PCIe adapter solution leveraging Broadcom's BroadSAFE[®] technology
- Supports Ethernet 50G PAM-4, 25G NRZ, and 10G NRZ signaling.
- Multi-Host up to four hosts.
- Fully compliant with the SFF-8402 standard.
- x16 PCI Express 4.0 compliant.
- SR-IOV with up to 1k virtual functions (VFs).
- Function-Level Reset (FLR) support.
- TruFlow[™] flow processing engine.
- Virtual Network Termination – VXLAN, NVGRE, Geneve, GRE encap/decap.
- vSwitch Acceleration.
- Tunnel-aware stateless offloads.
- DCB support – PFC, ETS, QCN, DCBx.
- RDMA over Converged Ethernet (RoCE)
- Network Controller Sideband Interface (NC-SI).
- SMBus 2.0.
- MCTP over SMBus.
- Jumbo frames up to 9 KB.
- Advanced congestion avoidance.
- Multiqueue, NetQueue, and VMQ.
- IPv4 and IPv6 offloads.
- TCP, UDP, and IP checksum offloads.
- Large send offload (LSO).
- Large receive offload (LRO).
- TCP segmentation offload (TSO).
- Receive-side scaling (RSS).
- Transmit-side scaling (TSS).
- VLAN insertion/removal.
- Interrupt coalescing.
- Network boot—PXE, UEFI.
- iSCSI boot.
- Wake-on-LAN (WOL).
- MSI and MSI-X.
- OCP 3.0 FRU support.
- Conforms to the OCP 3.0 Design Specification Version 1.0.

Applications

Dual-port 100-Gigabit Ethernet adapter for OCP systems.

Figure 1: BCM957508-N2100G OCP 3.0 SFF Network Adapter

NOTE: [Figure 1](#) shows the pull-tab bracket installed by default. The surface markings of the component may not reflect the product upon receipt. Broadcom reserves the right to change any component on the printed circuit board with the same functionality.

Table of Contents

- 1 Functional Description** 4
 - 1.1 Block Diagram..... 4
 - 1.2 Host Interface Connector 5
 - 1.3 BCM57508 Ethernet Controller..... 8
 - 1.4 PCI Express Interface 8
 - 1.5 NC-SI Interface 8
 - 1.6 SMBus Interface 8
 - 1.7 Non-Volatile RAM 8
 - 1.8 Heat Sink 8
 - 1.9 Power Supplies 8
 - 1.10 QSFP56 Connector..... 8
 - 1.11 LED Functions and Locations 9
- 2 Regulatory and Safety Approvals** 10
- 3 Board Power and Environmental Specifications** 10
- 4 Package Weight**..... 10
- 5 Physical Specifications** 11
- 6 Ordering Information** 11
- Revision History** 12

1 Functional Description

This section provides the functional description of the BCM957508-N2100G Network Adapter.

1.1 Block Diagram

Figure 2 shows the main functional blocks on the BCM957508-N2100G Network Adapter.

Figure 2: BCM957508-N2100G Block Diagram

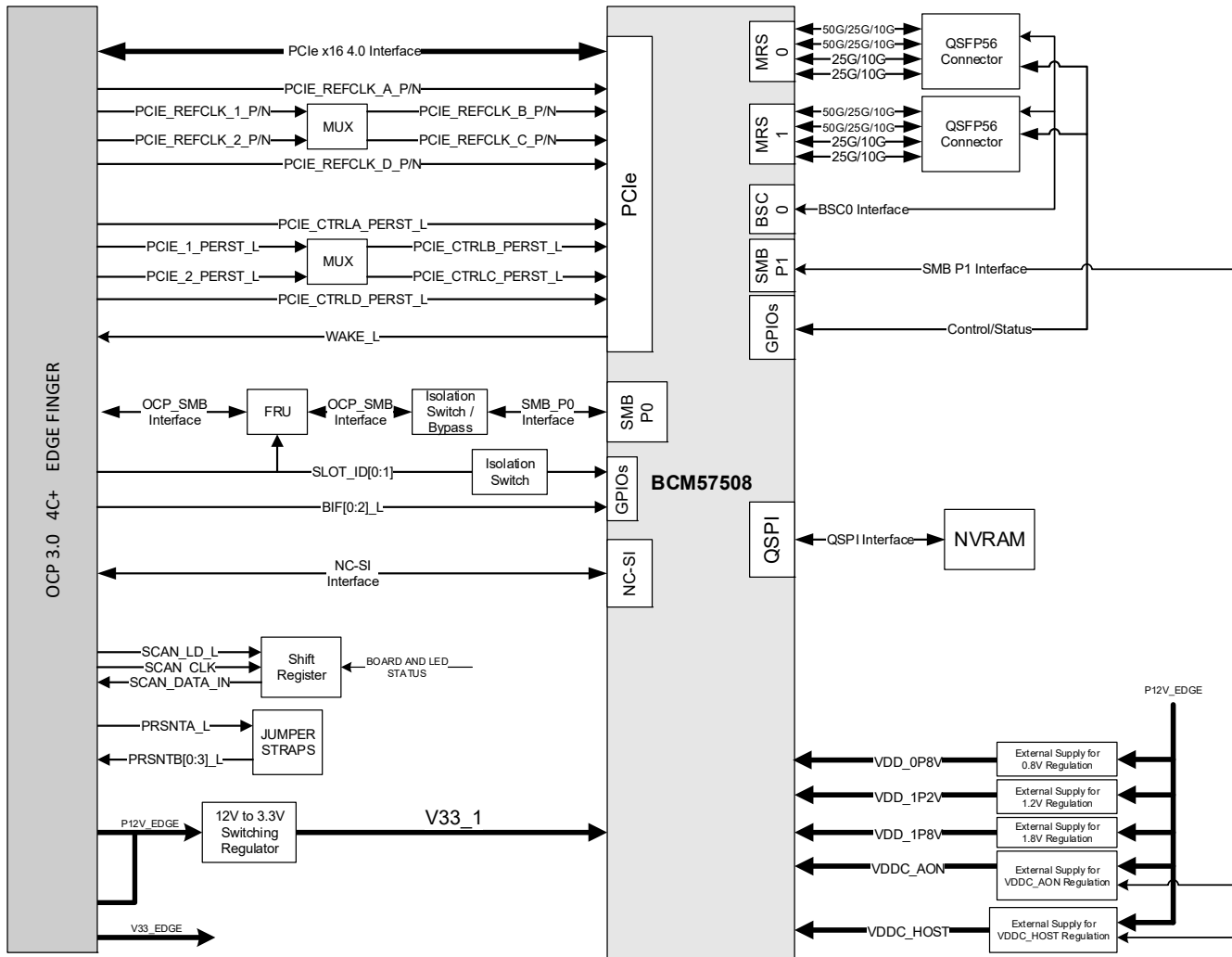

1.2 Host Interface Connector

The BCM957508-N2100G OCP network adapter interfaces with the system baseboard via the gold fingers compliant with the SFF-TA-1002 specification. The PCIe bus, NC-SI bus, SMBus interface, various other sideband signals, and power are assigned to this connector. The connector pinout complies with the primary connector (4C+ OCP) as described in the OCP 3.0 Design Specification. [Table 1](#) shows the signal pinout. Definitions of the signals at this connector are provided in the OCP 3.0 Design Specification.

Table 1: Primary Connector (4C+) Pinout

Side B		Side A	
OCP_B1	NIC_PWR_GOOD	PERST2#	OCP_A1
OCP_B2	MAIN_PWR_EN	PERST3#	OCP_A2
OCP_B3	LD#	WAKE#	OCP_A3
OCP_B4	DATA_IN	RBT_ARB_IN	OCP_A4
OCP_B5	DATA_OUT	RBT_ARB_OUT	OCP_A5
OCP_B6	CLK	SLOT_ID1	OCP_A6
OCP_B7	SLOT_ID0	RBT_TX_EN	OCP_A7
OCP_B8	RBT_RXD1	RBT_TXD1	OCP_A8
OCP_B9	RBT_RXD0	RBT_TXD0	OCP_A9
OCP_B10	GND	GND	OCP_A10
OCP_B11	REFCLKn2	REFCLKn3	OCP_A11
OCP_B12	REFCLKp2	REFCLKp3	OCP_A12
OCP_B13	GND	GND	OCP_A13
OCP_B14	RBT_CRIS_DV	RBT_CLK_IN	OCP_A14
Mechanical Key			
B1	+12V_EDGE	GND	A1
B2	+12V_EDGE	GND	A2
B3	+12V_EDGE	GND	A3
B4	+12V_EDGE	GND	A4
B5	+12V_EDGE	GND	A5
B6	+12V_EDGE	GND	A6
B7	BIF0#	SMCLK	A7
B8	BIF1#	SMDAT	A8
B9	BIF2#	SMRST#	A9
B10	PERST0#	PRSNTA#	A10
B11	+3.3V_EDGE	PERST1#	A11
B12	AUX_PWR_EN	PRSNTB2#	A12
B13	GND	GND	A13
B14	REFCLKn0	REFCLKn1	A14
B15	REFCLKp0	REFCLKp1	A15
B16	GND	GND	A16
B17	PETn0	PERn0	A17
B18	PETp0	PERp0	A18
B19	GND	GND	A19
B20	PETn1	PERn1	A20

Table 1: Primary Connector (4C+) Pinout (Continued)

Side B		Side A	
B21	PETp1	PERp1	A21
B22	GND	GND	A22
B23	PETn2	PERn2	A23
B24	PETp2	PERp2	A24
B25	GND	GND	A25
B26	PETn3	PERn3	A26
B27	PETp3	PERp3	A27
B28	GND	GND	A28
Mechanical Key			
B29	GND	GND	A29
B30	PETn4	PERn4	A30
B31	PETp4	PERp4	A31
B32	GND	GND	A32
B33	PETn5	PERn5	A33
B34	PETp5	PERp5	A34
B35	GND	GND	A35
B36	PETn6	PERn6	A36
B37	PETp6	PERp6	A37
B38	GND	GND	A38
B39	PETn7	PERn7	A39
B40	PETp7	PERp7	A40
B41	GND	GND	A41
B42	PRSENTB0#	PRSENTB1#	A42
Mechanical Key			
B43	GND	GND	A43
B44	PETn8	PERn8	A44
B45	PETp8	PERp8	A45
B46	GND	GND	A46
B47	PETn9	PERn9	A47
B48	PETp9	PERp9	A48
B49	GND	GND	A49
B50	PETn10	PERn10	A50
B51	PETp10	PERp10	A51
B52	GND	GND	A52
B53	PETn11	PERn11	A53
B54	PETp11	PERp11	A54
B55	GND	GND	A55
B56	PETn12	PERn12	A56
B57	PETp12	PERp12	A57
B58	GND	GND	A58
B59	PETn13	PERn13	A59
B60	PETp13	PERp13	A60

Table 1: Primary Connector (4C+) Pinout (Continued)

Side B		Side A	
B61	GND	GND	A61
B62	PETn14	PERn14	A62
B63	PETp14	PERp14	A63
B64	GND	GND	A64
B65	PETn15	PERn15	A65
B66	PETp15	PERp15	A66
B67	GND	GND	A67
B68	RFU1, N/C	USB_DATn	A68
B69	RFU2, N/C	USB_DATp	A69
B70	PRSNTB3#	PWRBRK0#	A70

1.3 BCM57508 Ethernet Controller

The BCM57508 Ethernet controller is configured as a dual-port 100 Gb/s interface to the line side and x16 PCI Express v4.0 interface to the system host.

1.4 PCI Express Interface

PCIe is a high-bandwidth serial bus providing a low pin-count interface as an alternative to parallel PCI. It is part of the host interface connector. The BCM57508 complies with the PCI Express Base Specification Revision 4.0, and supports a 16-lane PCIe 4.0 interface via the host interface connector.

1.5 NC-SI Interface

The BCM57508 Ethernet controller supports the Network Controller Sideband Interface (NC-SI) Specification version 1.1.0. The NC-SI provides a standardized interface between the system baseboard management controller (BMC) and the integrated NC-SI module of the BCM57508.

1.6 SMBus Interface

The BCM57508 Ethernet Controller SMB0 interface supports serial communications between the BCM57508 and the system. The interface allows the Ethernet controller to act as a SMBus primary or a secondary device.

1.7 Non-Volatile RAM

The BCM57508 Ethernet controller requires a non-volatile serial flash memory (NVRAM) to store the device firmware, PCI configuration space settings (for example, device ID, vendor ID), MAC address, and so on. After power-up, the firmware is downloaded into the device memory and executed by the on-chip processor.

1.8 Heat Sink

The passive heat sink is attached to the Ethernet controller using four spring-loaded push pins that are inserted into four mounting holes.

1.9 Power Supplies

All power is derived from the network adapter host interface connector 12V and 3.3V supply which feeds the onboard regulators that provide the necessary power to the various components on the network adapter. The network adapter has six switching voltage regulators that power the adapter's VDDC_AON, VDDC_HOST, +0.8V, +1.2V, +1.8V, and +3.3V loads.

1.10 QSFP56 Connector

The BCM957508-N2100G integrates two QSFP56 connectors to support 50G PAM-4, 25G NRZ, or 10G NRZ signaling for 10050/40/25/10 Gb/s on each port. QSFP56 is backward compatible with QSFP28 and QSFP+ when appropriate cables and transceivers are used.

1.11 LED Functions and Locations

The QSFP56 port supports two LEDs to indicate traffic activities and link speed. The LEDs are visible as shown in [Figure 3](#). Its locations and form factors conform to the OCP 3.0 Design Specification.

Figure 3: Activity and Link LED Locations

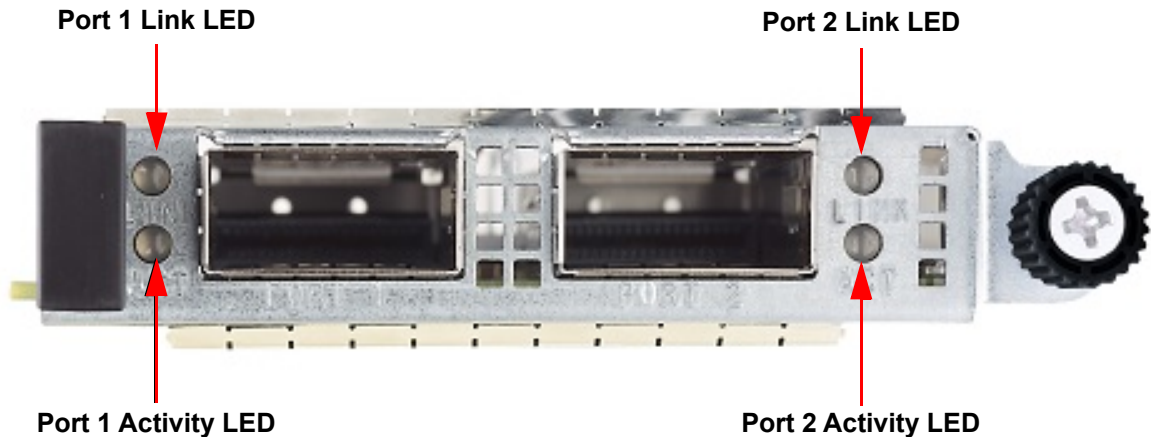

NOTE: [Figure 3](#) shows the pull-tab bracket installed by default. The surface markings of the component may not reflect the product upon receipt. Broadcom reserves the right to change any component on the printed circuit board with the same functionality.

Table 2: LED Functions

LED Type	Color/Behavior	Note
Activity	Off	No Activity
	Green (blinking)	Link up (traffic flowing)
Link	Off	No Link
	Green	Linked at 100 Gb/s
	Amber	Linked at lower speed

2 Regulatory and Safety Approvals

The BCM957508-N2100G network adapter meets the regulatory requirements of OCP 3.0 Design Specification. For additional information on required compliance including environmental, EMC, Product Safety, and immunity (ESD), reference the OCP 3.0 Design Specification.

3 Board Power and Environmental Specifications

Table 3 provides the adapter power consumption.

Table 3: Adapter Power Consumption

Adapter Power ^a	Passive DAC Cable	Optical Transceiver ^b
Typical – 50% Ethernet traffic	15.3W	19.8W
Max – 100% Ethernet traffic	16.4W	21.0W

a. Power consumption of adapter at 55°C ambient temperature.

b. Power consumption of adapter is measured using a Broadcom AFBR-89CDHZ power class 3 optical transceiver. The total adapter power adapter may vary with different optical transceivers.

Table 4: Adapter Environmental Specifications

Airflow	Ambient Temperature	Passive DAC Cable	Optical Transceiver ^a
Cold Aisle	45°C	Tier 7, 210 LFM	Tier 7, 240 LFM
Hot Aisle	55°C	Tier 5, 245 LFM	Tier 8, 400 LFM
Storage Humidity	Relative Humidity Range (Non-condensing) maximum 90% at 35°C		
Storage Temperature	-40°C to 70°C		
Operating Temperature	0°C to 55°C		

a. Airflow requirements are measured using a Broadcom AFBR-89CDHZ (power class 3, commercial temp [70°C]) optical transceiver. Check the airflow requirements of the selected optical transceivers to ensure adequate cooling to the optical transceivers.

4 Package Weight

Table 5 shows the BCM957508-N2100G package weight with the pull-tab bracket installed by default (excluding the optical module).

Table 5: Package Weight

Parameter	Symbol	Value	Unit
BCM957508-N2100G weight	g	110	gram

5 Physical Specifications

The physical board dimensions are compliant with the OCP 3.0 Design Specification, Small Form Factor (SFF) network adapter, and faceplate. See the mechanical dimensions in the OCP 3.0 Design Specification for additional information.

The BCM957508-N2100G supports all three faceplates, for example, pull tab, ejector latch, and internal lock. The pull tab is installed by default. For additional mechanical dimensions, see the OCP 3.0 Design Specification.

6 Ordering Information

Table 6: Ordering Information

Part Number	Description
BCM957508-N2100G	Dual-Port 100 Gb/s Ethernet PCI Express 4.0 x16 OCP 3.0 Network Adapter, Halogen-Free

Revision History

957508-N2100G-DS106; September 22, 2022

Updated:

- [Features](#) – Added 25G NRZ and 10G NRZ support.
- [QSFP56 Connector](#) – Added 25G NRZ and 10G NRZ support.

957508-N2100G-DS105; February 7, 2022

Updated:

- SMBus Interface – Updated description.
- Table 2, LED Functions – Changed Link to Activity.

957508-N2100G-DS104; August 20, 2021

Updated:

- Board Power and Environmental Specifications – Updated the entire section.

957508-N2100G-DS103; November 24, 2020

Updated:

- Board Airflow Requirement and Power Consumption – Updated the entire section.

957508-N2100G-DS102; January 3, 2020

Updated:

- Features – Updated OCP 3.0 Design Specification Version to 1.0
- Airflow Requirements – Updated airflow requirements.

957508-N2100G-DS101; October 24, 2019

Updated:

- Host Interface Connector – Updated version number.
- Board Power Consumption – Updated power consumption.

957508-N2100G-DS100; February 18, 2019

Initial release.

Copyright © 2019-2023 Broadcom. All Rights Reserved. The term “Broadcom” refers to Broadcom Inc. and/or its subsidiaries. For more information, go to www.broadcom.com. All trademarks, trade names, service marks, and logos referenced herein belong to their respective companies.

Broadcom reserves the right to make changes without further notice to any products or data herein to improve reliability, function, or design. Information furnished by Broadcom is believed to be accurate and reliable. However, Broadcom does not assume any liability arising out of the application or use of this information, nor the application or use of any product or circuit described herein, neither does it convey any license under its patent rights nor the rights of others.