

BCM957412N4120C

Dual-Port 10 Gb/s Ethernet PCI Express 3.0 x8 OCP 3.0 Small-Form-Factor Network Adapter

General Description

The Broadcom[®] BCM957412N4120C is a dual-port 10 Gb/s PCI Express 3.0 x8 network adapter designed to the Open Compute Project (OCP) 3.0 Design Specification in small form factor with two SFP+ network connectors. The adapter supports SFP+ optical modules and copper direct-attach cables. The network adapter uses the Broadcom BCM57412 25GbE MAC controller with an integrated dual-channel 10GbE SFI transceiver.

Features

- Dual-port pluggable media interface, which can connect to a 10G SFP+ optical transceiver or a copper direct-attach cable.
- Fully compliant with the SFF-8402 standard.
- x8 PCI Express 3.0 compliant.
- SR-IOV with up to 128 virtual functions (VFs).
- Function-Level Reset (FLR) support.
- TruFlow[™] flow processing engine.
- Virtual Network Termination—VXLAN, NVGRE, Geneve, GRE encap/decap.
- vSwitch Acceleration.
- Tunnel-aware stateless offloads.
- DCB support – PFC, ETS, QCN, DCBx.
- RDMA over Converged Ethernet (RoCE).
- Network Controller Sideband Interface (NC-SI).
- SMBus 2.0.
- MCTP over SMBus.
- PCIe-based UART and KCS.
- Jumbo frames up to 9 KB.
- Advanced congestion avoidance.
- Multiqueue, NetQueue, and VMQ.
- IPv4 and IPv6 offloads.
- TCP, UDP, and IP checksum offloads.
- Large send offload (LSO).
- Large receive offload (LRO).
- TCP segmentation offload (TSO).
- Receive-side scaling (RSS).

- Transmit-side scaling (TSS).
- VLAN insertion/removal.
- Interrupt coalescing.
- Network boot—PXE, UEFI.
- iSCSI boot.
- Wake-on-LAN (WOL).
- MSI and MSI-X.
- Conforms to the OCP 3.0 Design Specification Version 1.00.

Applications

Dual-port 10-Gigabit Ethernet adapter for OCP systems.

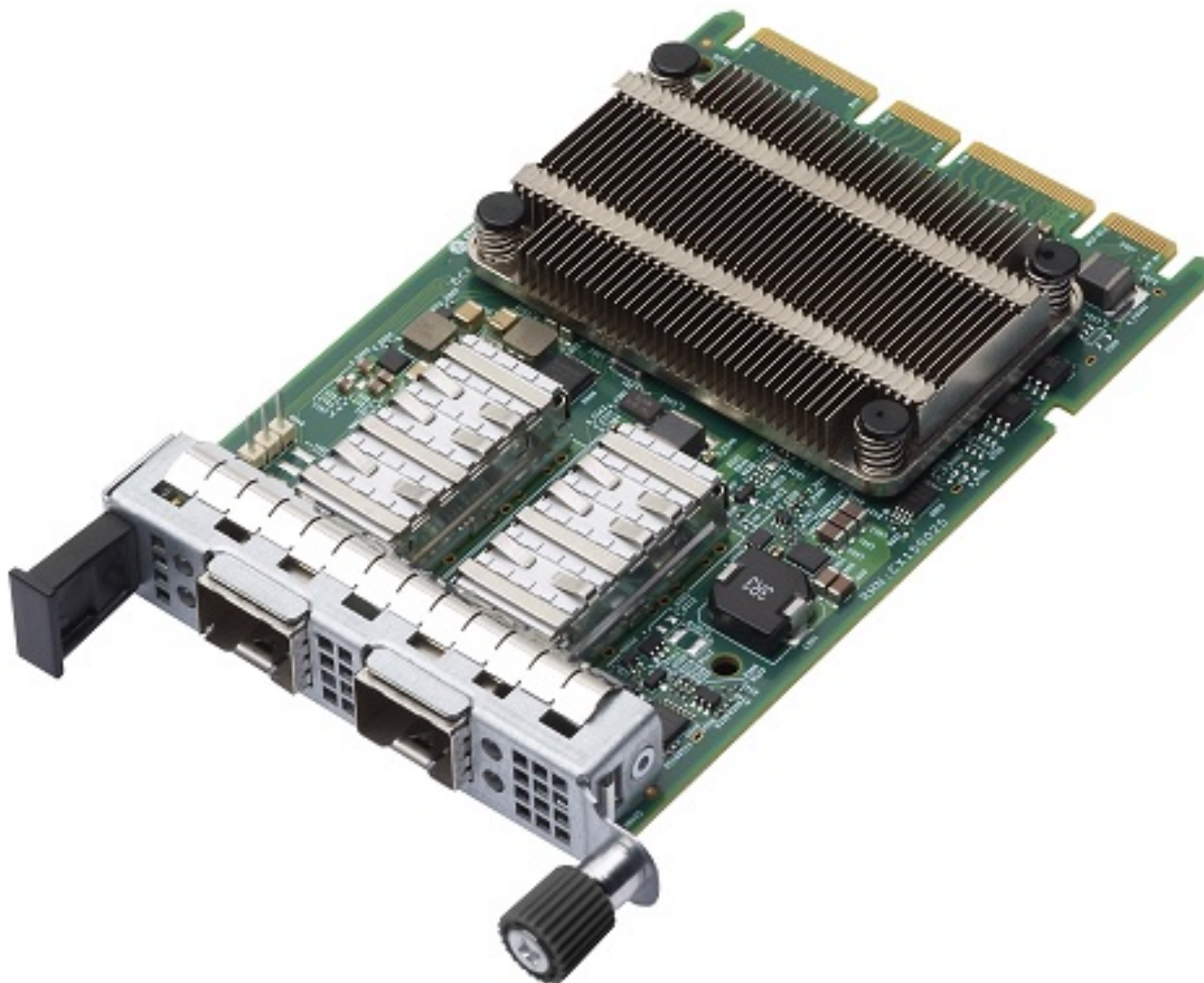
Figure 1: BCM957412N4120C OCP 3.0 SFF Network Adapter

NOTE: [Figure 1](#) shows the pull-tab bracket installed by default. The surface markings of the component may not reflect the product you receive. Broadcom reserves the right to change any component on the printed circuit board with the same functionality.

Table of Contents

1 Functional Description	4
1.1 Block Diagram.....	4
1.2 Host Interface Connector	5
1.3 BCM57412 Ethernet Controller.....	8
1.4 PCI Express Interface	8
1.5 NC-SI Interface	8
1.6 SMBus Interface	8
1.7 Nonvolatile RAM	8
1.8 Heat Sink	8
1.9 Power Supplies	8
1.10 LED Functions and Locations	9
2 Regulatory and Safety Approvals	10
3 Board Power and Environmental Specifications	10
4 Package Weight	10
5 Physical Specifications	11
6 Ordering Information	11
Revision History	12

1 Functional Description

This section provides the functional description of the BCM957412N4120C network adapter.

1.1 Block Diagram

Figure 2 shows the main functional blocks on the BCM957412N4120C network adapter.

Figure 2: BCM957412N4120C Block Diagram

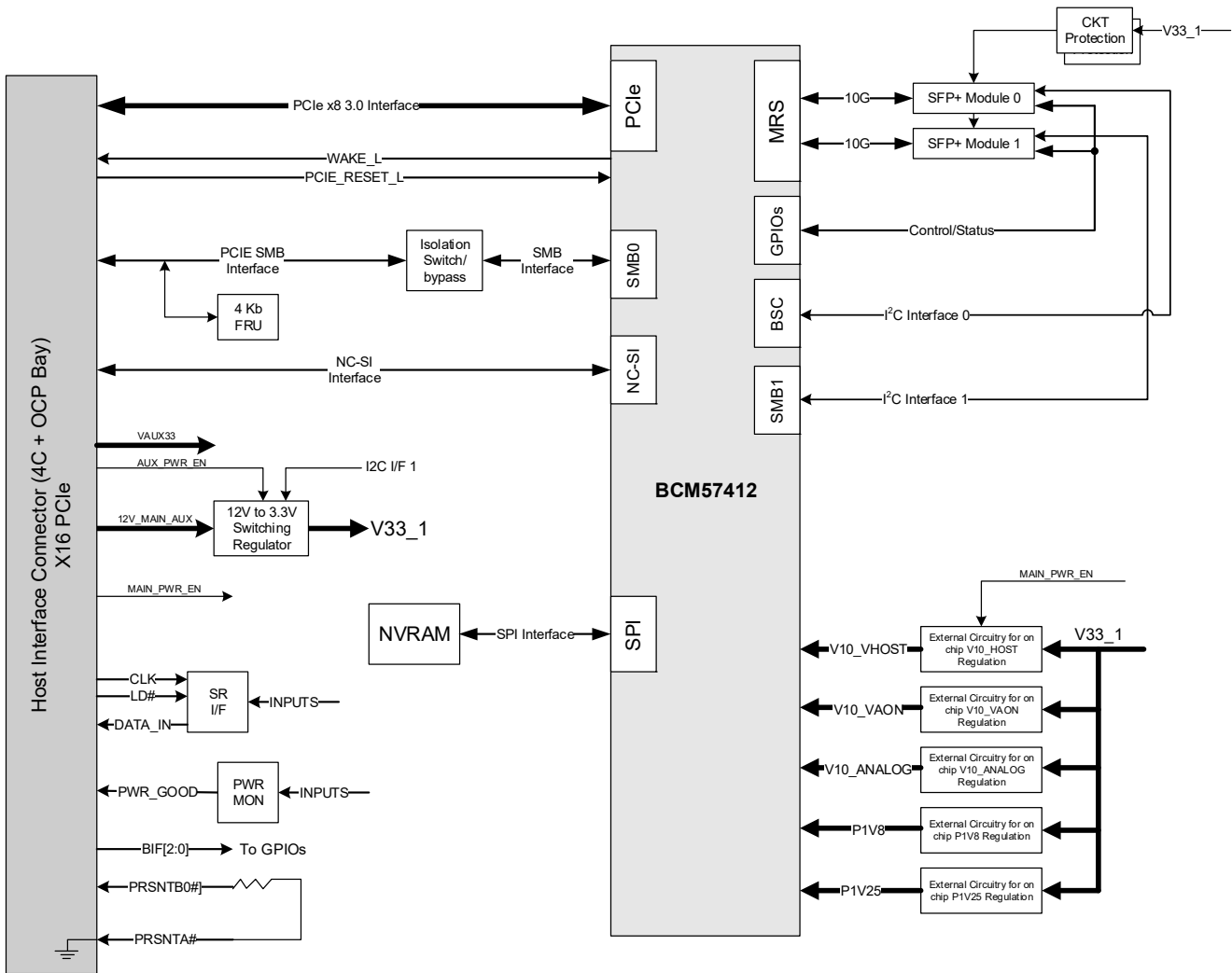

1.2 Host Interface Connector

The BCM957412N4120C OCP network adapter interfaces with the system baseboard via the gold fingers compliant with the SFF-TA-1002 specification. The PCIe bus, NC-SI bus, SMBus interface, various other sideband signals, and power are assigned to this connector. The connector pinout complies with the primary connector (4C+OCP) as described in the OCP 3.0 Design Specification. [Table 1](#) shows the signal pinout. Definitions of the signals at this connector are provided in the OCP 3.0 Design Specification.

Table 1: Primary Connector (4C+) Pinout

Side B		Side A	
OCP_B1	NIC_PWR_GOOD	PERST2#	OCP_A1
OCP_B2	MAIN_PWR_EN	PERST3#	OCP_A2
OCP_B3	LD#	WAKE#	OCP_A3
OCP_B4	DATA_IN	RBT_ARB_IN	OCP_A4
OCP_B5	DATA_OUT	RBT_ARB_OUT	OCP_A5
OCP_B6	CLK	SLOT_ID1	OCP_A6
OCP_B7	SLOT_ID0	RBT_TX_EN	OCP_A7
OCP_B8	RBT_RXD1	RBT_TXD1	OCP_A8
OCP_B9	RBT_RXD0	RBT_TXD0	OCP_A9
OCP_B10	GND	GND	OCP_A10
OCP_B11	REFCLKn2	REFCLKn3	OCP_A11
OCP_B12	REFCLKp2	REFCLKp3	OCP_A12
OCP_B13	GND	GND	OCP_A13
OCP_B14	RBT_CRSDV	RBT_CLK_IN	OCP_A14
Mechanical Key			
B1	+12V_EDGE	GND	A1
B2	+12V_EDGE	GND	A2
B3	+12V_EDGE	GND	A3
B4	+12V_EDGE	GND	A4
B5	+12V_EDGE	GND	A5
B6	+12V_EDGE	GND	A6
B7	BIF0#	SMCLK	A7
B8	BIF1#	SMDAT	A8
B9	BIF2#	SMRST#	A9
B10	PERST0#	PRSNTA#	A10
B11	+3.3V_EDGE	PERST1#	A11
B12	AUX_PWR_EN	PRSNTB2#	A12
B13	GND	GND	A13
B14	REFCLKn0	REFCLKn1	A14
B15	REFCLKp0	REFCLKp1	A15
B16	GND	GND	A16
B17	PETn0	PERn0	A17
B18	PETp0	PERp0	A18
B19	GND	GND	A19
B20	PETn1	PERn1	A20

Table 1: Primary Connector (4C+) Pinout (Continued)

Side B		Side A	
B21	PETp1	PERp1	A21
B22	GND	GND	A22
B23	PETn2	PERn2	A23
B24	PETp2	PERp2	A24
B25	GND	GND	A25
B26	PETn3	PERn3	A26
B27	PETp3	PERp3	A27
B28	GND	GND	A28
Mechanical Key			
B29	GND	GND	A29
B30	PETn4	PERn4	A30
B31	PETp4	PERp4	A31
B32	GND	GND	A32
B33	PETn5	PERn5	A33
B34	PETp5	PERp5	A34
B35	GND	GND	A35
B36	PETn6	PERn6	A36
B37	PETp6	PERp6	A37
B38	GND	GND	A38
B39	PETn7	PERn7	A39
B40	PETp7	PERp7	A40
B41	GND	GND	A41
B42	PRSNB0#	PRSNB1#	A42
Mechanical Key			
B43	GND	GND	A43
B44	PETn8	PERn8	A44
B45	PETp8	PERp8	A45
B46	GND	GND	A46
B47	PETn9	PERn9	A47
B48	PETp9	PERp9	A48
B49	GND	GND	A49
B50	PETn10	PERn10	A50
B51	PETp10	PERp10	A51
B52	GND	GND	A52
B53	PETn11	PERn11	A53
B54	PETp11	PERp11	A54
B55	GND	GND	A55
B56	PETn12	PERn12	A56
B57	PETp12	PERp12	A57
B58	GND	GND	A58
B59	PETn13	PERn13	A59
B60	PETp13	PERp13	A60

Table 1: Primary Connector (4C+) Pinout (Continued)

Side B		Side A	
B61	GND	GND	A61
B62	PETn14	PERn14	A62
B63	PETp14	PERp14	A63
B64	GND	GND	A64
B65	PETn15	PERn15	A65
B66	PETp15	PERp15	A66
B67	GND	GND	A67
B68	RFU1, N/C	USB_DATn	A68
B69	RFU2, N/C	USB_DATp	A69
B70	PRSNTB3#	PWRBRK0#	A70

1.3 BCM57412 Ethernet Controller

The BCM57412 Ethernet controller is configured as dual-port 10 Gb/s MAC with integrated SFP+ optical interface to the line side and x8 PCI Express v3.0 interface to the system host.

1.4 PCI Express Interface

PCIe is a high-bandwidth serial bus providing a low-pin-count interface as an alternative to parallel PCI. It is part of the host interface connector. The BCM57412 complies with the PCI Express Base Specification Revision 3.0, and supports an 8-lane PCIe 3.0 interface via the host interface connector.

1.5 NC-SI Interface

The BCM57412 Ethernet controller supports the Network Controller Sideband Interface (NC-SI) Specification version 1.1.0. The NC-SI provides a standardized interface between the system baseboard management controller (BMC) and the integrated NC-SI module of the BCM57412.

1.6 SMBus Interface

The BCM57412 Ethernet Controller SMB0 interface supports serial communications between the BCM57412 and the system. The interface allows the Ethernet controller to act as a SMBus primary or a secondary device.

1.7 Nonvolatile RAM

The BCM57412 Ethernet controller requires a nonvolatile serial flash memory (NVRAM) to store the device firmware, PCI configuration space settings (for example, device ID, vendor ID), MAC address, and so on. After power-up, the firmware is downloaded into the device memory and executed by the on-chip processor.

1.8 Heat Sink

The passive heat sink is attached to the Ethernet controller using four spring-loaded push pins that insert into four mounting holes.

To prevent damage to the BCM57412 Ethernet controller in the event of a missing heat sink, the network adapter is not allowed to power up.

1.9 Power Supplies

All power is derived from the network adapter interface connector 12V and 3.3V supply which feeds the onboard regulators that provide the necessary power to the various components on the network adapter. The network adapter has six switching voltage regulators that power the card's various +1.0V, +1.25V, +1.8V, and +3.3V loads.

1.10 LED Functions and Locations

The SFP+ port supports two LEDs to indicate traffic activities and link speed. The LEDs are visible as shown in [Figure 3](#). Its locations and form factors conform to the OCP 3.0 Design Specification.

Figure 3: Activity and Link LED Locations

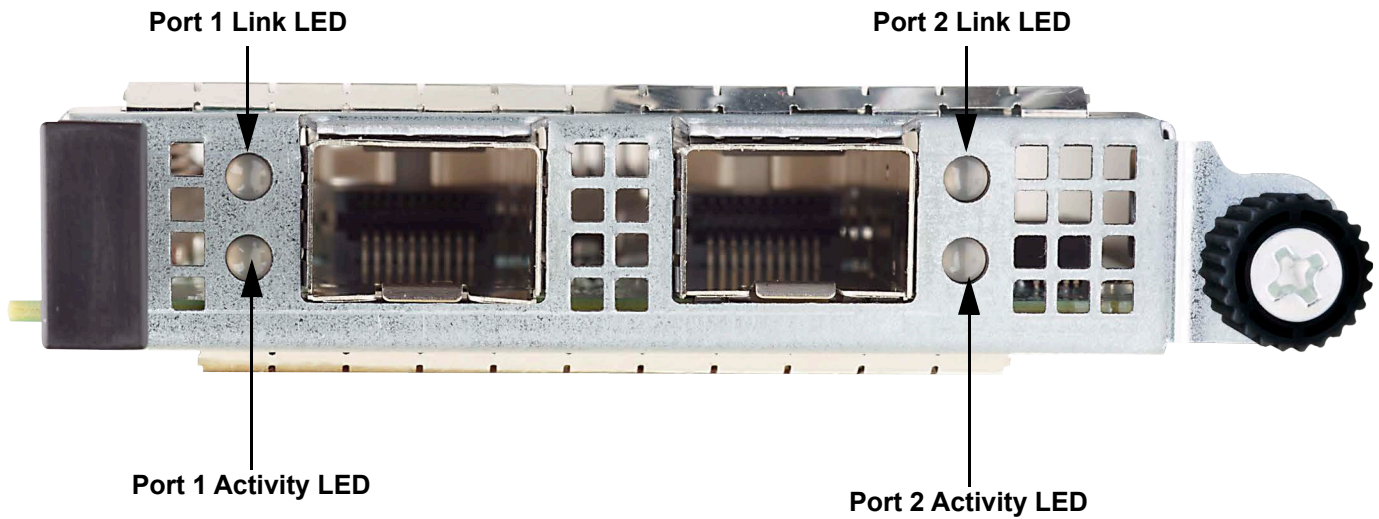

Table 2: LED Functions

LED Type	Color/Behavior	Note
Activity	Off	No Activity
	Green (blinking)	Link up (traffic flowing)
Link	Off	No Link
	Green	Linked at 10 Gb/s
	Amber	Linked at 1 Gb/s

2 Regulatory and Safety Approvals

The BCM957412N4120C network adapter meets the regulatory requirements of the OCP 3.0 Design Specification. For additional information on required compliance including environmental, EMC, Product Safety, and immunity (ESD), reference the OCP 3.0 Design Specification.

3 Board Power and Environmental Specifications

Table 3 provides the adapter power consumption.

Table 3: Adapter Power Consumption

Adapter Power ^a	Power Reduction ^b Disabled		Power Reduction Enabled	
	Passive DAC Cable	Optical Transceiver ^c	Passive DAC Cable	Optical Transceiver
Typical – 50% Ethernet traffic	8.1W	9.5W	5.5W	7.9W
Max – 100% Ethernet traffic	8.5W	9.8W	5.9W	8.2W

- Power consumption of adapter at 55°C ambient temperature.
- Reference Broadcom Product Advisory PA-253336 for Power Reduction details or contact the Broadcom FAE for additional information.
- Power consumption of adapter is measured using a Broadcom AFBR-735SMZ power level 1 optical transceiver. The total adapter power may vary with different optical transceivers.

Table 4 provides the adapter environmental specifications. The system designer may deploy methods to monitor the BCM57412 junction temperature (T_j) and provide sufficient airflow for keeping T_j below 105°C during normal operation. The Broadcom AFBR-735SMZ active transceiver is recommended for the application.

Table 4: Adapter Environmental Specifications

Airflow	Ambient Temperature	Passive DAC Cable	Optical Transceiver ^a
Cold Aisle	45°C	Tier 2, 50 LFM	Tier 2, 50 LFM
Hot Aisle	55°C	Tier 2, 100 LFM	Tier 2, 100 LFM
Storage Humidity	Relative Humidity Range (Non-condensing) maximum 90% at 35°C		
Storage Temperature	-40°C to 70°C		
Operating Temperature	0°C to 55°C		

- Airflow requirements are measured using a Broadcom AFBR-735SMZ (power level 1, commercial temp [70°C]) optical transceivers. Check the airflow requirements of the selected optical transceivers to ensure adequate cooling to the optical transceivers.

4 Package Weight

Table 5 shows the BCM957412N4120C package weight (excluding faceplate, optical module, and so on).

Table 5: Package Weight

Parameter	Symbol	Value	Unit
BCM957412N4120C weight	g	91	gram

5 Physical Specifications

The physical board dimensions are compliant with the OCP 3.0 Design Specification, Small Form Factor (SFF), and faceplate. See the mechanical dimensions in the OCP 3.0 Design Specification for additional information.

The BCM957412N4120C supports all three faceplates, for example, pull tab, ejector latch, and internal lock. The pull tab is installed by default. For additional mechanical dimensions, see the OCP 3.0 Design Specification.

6 Ordering Information

Table 6: Ordering Information

Part Number	Description
BCM957412N4120C	Dual-Port 10 Gb/s Ethernet PCI Express 3.0 x8 OCP 3.0 Network Adapter, Halogen-Free, Pull-Tab Bracket
BCM957412N4120CI	Dual-Port 10 Gb/s Ethernet PCI Express 3.0 x8 OCP 3.0 Network Adapter, Halogen-Free, Internal Lock Bracket

Revision History

BCM957412N4120C-DS105; December 21, 2022

Updated:

- [Table 3, Adapter Power Consumption](#) – Updated entire table.

BCM957412N4120C-DS104; March 25, 2022

Updated:

- SMBus Interface – Updated description.
- Table 2, LED Functions – Changed Link to Activity.
- Table 6, Ordering Information – Updated part number information.

BCM957412N4120C-DS103; August 31, 2021

Updated:

- Board Power and Environmental Specifications – Updated section.

BCM957412N4120C-DS102; January 22, 2020

Updated:

- Board Power Consumption – Updated case temperature information.

BCM957412N4120C-DS101; January 2, 2020

Updated:

- Features – Updated OCP 3.0 Design Specification Version to 1.00.

BCM957412N4120C-DS100; January 25, 2019

Initial release.

Broadcom, the pulse logo, Connecting everything, TruFlow, Avago Technologies, Avago, and the A logo are among the trademarks of Broadcom and/or its affiliates in the United States, certain other countries and/or the EU.

Copyright © 2019-2022 Broadcom. All Rights Reserved.

The term “Broadcom” refers to Broadcom Inc. and/or its subsidiaries. For more information, please visit www.broadcom.com.

Broadcom reserves the right to make changes without further notice to any products or data herein to improve reliability, function, or design. Information furnished by Broadcom is believed to be accurate and reliable. However, Broadcom does not assume any liability arising out of the application or use of this information, nor the application or use of any product or circuit described herein, neither does it convey any license under its patent rights nor the rights of others.

