

BCM957412A4120AC

Dual-Port 10 Gb/s Ethernet PCI Express Gen3 x8 Network Interface Card

Overview

The Broadcom[®] BCM957412A4120AC is a dual-port 10 Gb/s, PCI-Express Gen3 x8 Network Interface Card that supports both SFP+ optical modules and copper direct-attach cable. The card uses the Broadcom BCM57412 10GbE MAC controller with the integrated dual-channel 10GbE SFI transceiver.

Features

- Dual-port pluggable media interface, which may be equipped with a 10G SFP+ optical transceiver or with copper direct-attach cable.
- Fully compliant with SFF-8402 standard.
- x8 PCI Express v3.0 compliant.
- SR-IOV with up to 128 VFs.
- Function Level Reset (FLR) support.
- TruFlow[™] flow processing engine.
- Virtual Network Termination–VXLAN, NVGRE, GRE encaps/decap.
- vSwitch acceleration.
- Tunnel-aware stateless offloads.
- RDMA over converged Ethernet (RoCE).
- SMBus 2.0.
- MCTP over SMBus.
- PCIe-based UART and KCS.
- Jumbo frames up to 9 KB.
- Advanced Congestion Avoidance.
- Multiqueue, NetQueue, and VMQ.
- IPv4 and IPv6 offloads.
- TCP, UDP, and IP checksum offloads.
- Large Send Offload (LSO).
- Large Receive Offload (LRO).
- TCP Segmentation Offload (TSO).
- Receive-side Scaling (RSS).
- Transmit-side Scaling (TSS).
- VLAN insertion/removal.
- Interrupt coalescing.

- Network boot-PXE, UEFI.
- iSCSI boot.
- MSI and MSI-X.
- Supports Wake-on-LAN
- Conforms to the PCI Express Card Electromechanical Specification Rev. 3.0.

Applications

Dual-Port 10-Gigabit Ethernet Network Interface Card for Data Centers or Cloud Computing.

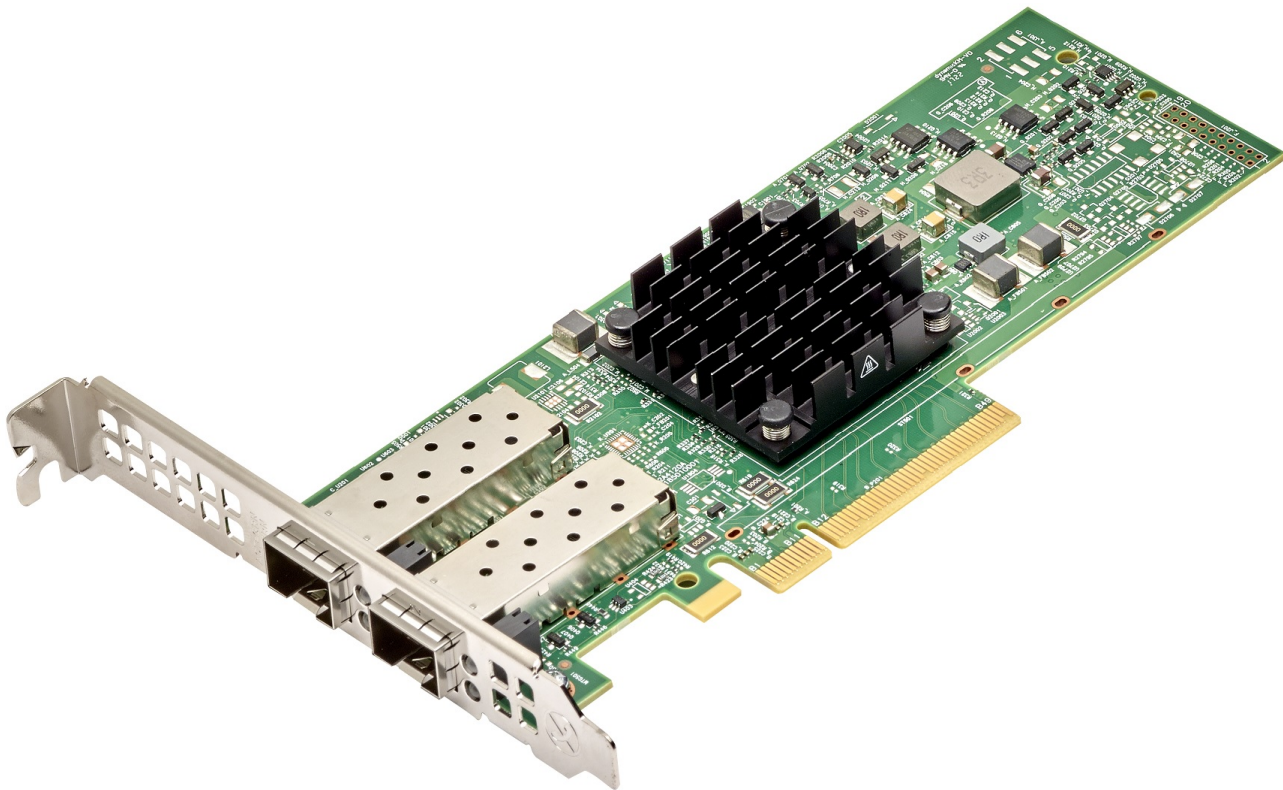
Figure 1: BCM957412A4120AC Network Interface Card

NOTE: The surface markings of the component may not reflect the product received. Broadcom reserves the right to change any component on the printed circuit board with the same functionality.

Table of Contents

1 Introduction	4
2 Functional Description	4
2.1 Block Diagram.....	4
2.2 Host Interface Connector	5
2.3 BCM57412	5
2.4 SMBus Interface	5
2.5 Nonvolatile RAM	5
2.6 Heat Sink	5
2.7 DC/DC Regulators	5
2.8 Power Supplies	5
2.9 LED Functions and Locations	5
3 Regulatory and Safety Approvals	7
3.1 Regulatory.....	7
3.2 Safety.....	7
3.3 Electromagnetic Compatibility (EMC)	7
3.4 Electrostatic Discharge (ESD) Compliance	8
3.5 FCC Statement	8
4 Board Power and Environmental Specifications	9
5 Package Weight	10
6 Physical and Electrical Specifications	10
6.1 Board Physical Dimensions	10
6.2 Bracket Outlines and Dimensions	11
6.3 Standard-Profile Bracket Outline and Dimensions.....	11
6.4 Low-Profile Bracket Outline and Dimensions.....	12
7 Ordering Information	13
Revision History	14
957412A4120AC-DS107; February 14, 2023	14
957412A4120AC-DS106; December 21, 2022	14
957412A4120AC-DS105; March 15, 2022	14
957412A4120AC-DS104; November 3, 2020	14
957412A4120AC-DS103; July 9, 2020	14
957412A4120AC-DS102; June 18, 2020	14
957412A4120AC-DS101; December 26, 2017	14
957412A4120AC-DS100; April 3, 2017	15

1 Introduction

This document is for designers interested in integrating the BCM957412A4120AC network interface card into their hardware designs, and for others requiring specific data about the physical characteristics and operation of the BCM957412A4120AC.

2 Functional Description

This section provides the functional description of the BCM957412A4120AC network interface card.

2.1 Block Diagram

Figure 2 shows the main functional blocks on the BCM957412A4120AC network interface card.

Figure 2: BCM957412A4120AC Block Diagram

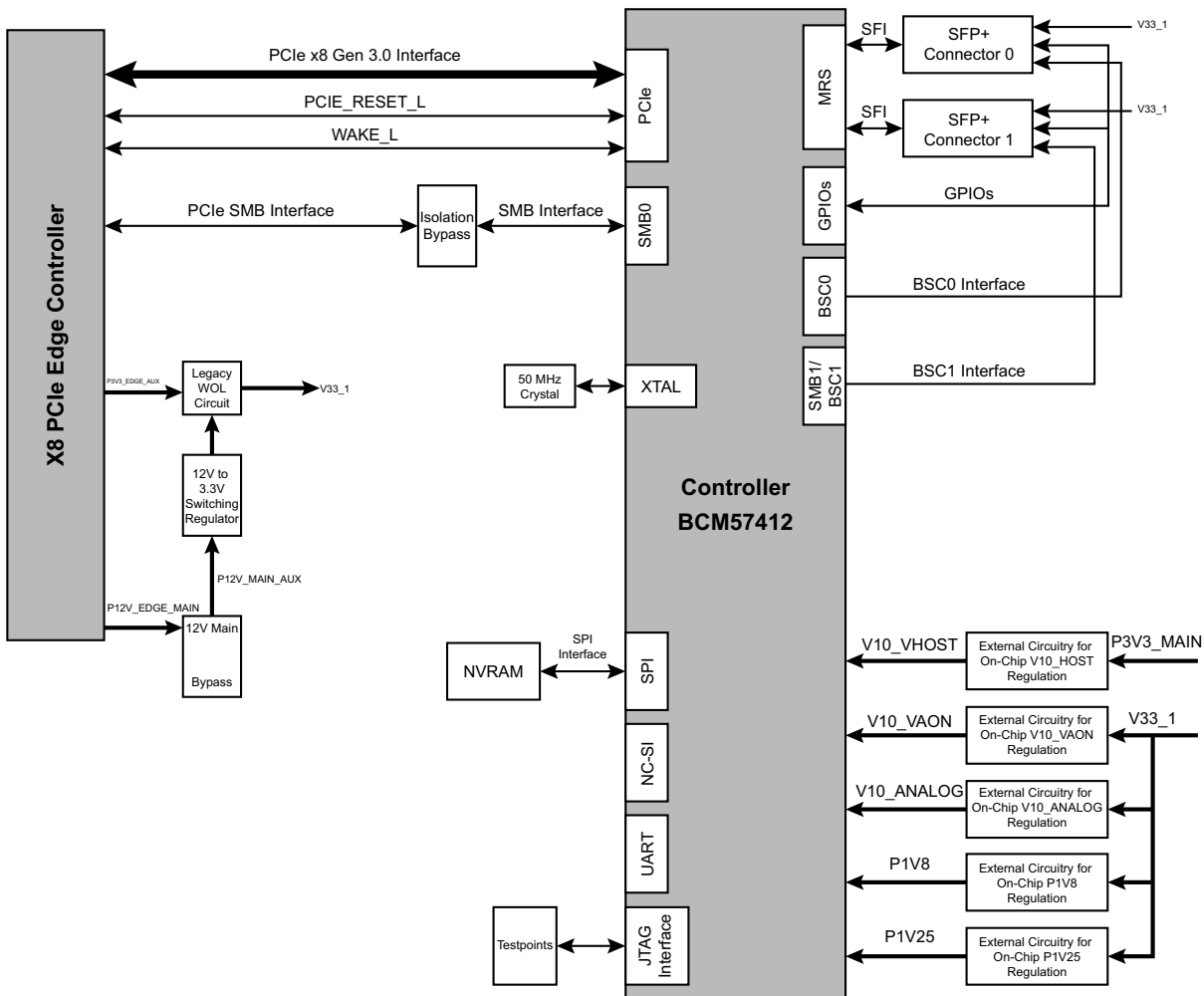

2.2 Host Interface Connector

The BCM957412A4120AC NIC is a PCI Express Gen3 x8 add-in card with standard height bracket. The card edge connector complies with the PCI Express Gen3 x8 standard pinout for add-in cards outlined in the PCI Express Electromechanical Specification v3.0 section 6.1, table 6-1.

The PCI Express interface is Gen3 compliant.

NOTE: Refer to section 6 of the PCI Express Electromechanical Specification v3.0 for more details on the card edge connector pinout, and section 9 for add-in card mechanical information.

2.3 BCM57412

The BCM57412 Ethernet Controller is configured as dual-port 10 Gb/s MAC with an integrated SFI interface on the network side and x8 PCI Express v3.0 interface to the system host.

2.4 SMBus Interface

The BCM57412 Ethernet Controller SMB0 interface supports serial communications between BCM57412 and the system. The interface allows the Ethernet Controller to act as a SMBus primary or a secondary device.

2.5 Nonvolatile RAM

The BCM57412 Ethernet Controller requires a nonvolatile serial flash memory (NVRAM) to store the device firmware, PCI Configuration space settings (for example, Device ID, Vendor ID), MAC address, and so on. After power-up, the firmware is downloaded into the device memory and executed by the on-chip processor.

2.6 Heat Sink

The passive heat sink is attached to the Ethernet Controller using four spring-loaded push pins that insert into four mounting holes.

2.7 DC/DC Regulators

The onboard voltage regulators use the 12V edge main power from the host interface connector to derive the necessary power rails for different circuits and components on the board.

2.8 Power Supplies

All power is derived from the PCI Express Host Interface Connector 12V supply pins. These voltage supply pins feed on-board regulators that provide the necessary power to the various components on the card. The NIC has six switching regulators, which power the card's various +1.0V, +1.25V, +1.8V, and +3.3V loads. The 3.3V power (+3.3V) and 3.3V auxiliary power (3.3V_{aux}) from the PCIe edge connector are also used to supply the power control logic and signals.

2.9 LED Functions and Locations

The SFP+ port supports two LEDs to indicate traffic activities and link speed. The LEDs are visible through the cutout on the bracket as shown in [Figure 3](#). The LED functionality is described in [Table 1](#).

Figure 3: Activity and Link LED Locations

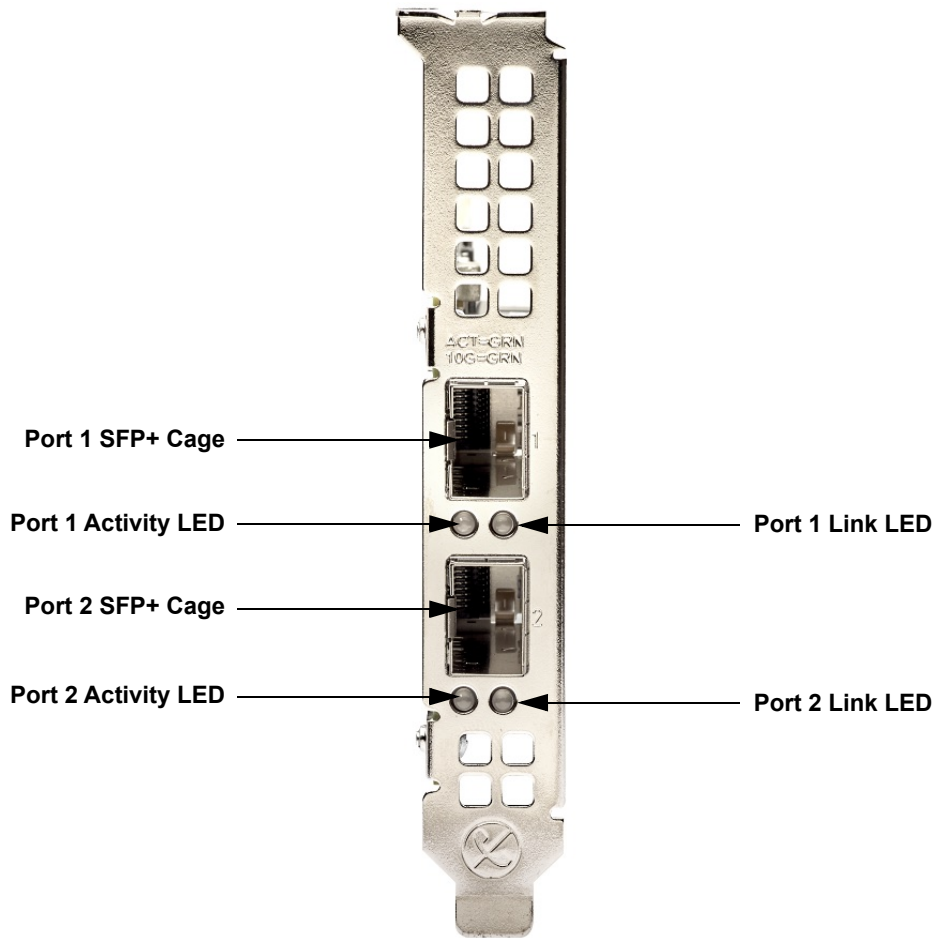

NOTE: Broadcom reserves the right to change any marking on the bracket which will not affect any functionality of the card.

Table 1: LED Functions

NVRAM Manufacturer	Device	Mbit
Activity	Off	No Activity
	Green blinking	Traffic Flowing Activity
Link	Off	No Link
	Green	Linked at 10 Gb/s
	Yellow	Linked at 1 Gb/s

3 Regulatory and Safety Approvals

The following sections detail the Regulatory, Safety, Electromagnetic Compatibility (EMC), and Electrostatic Discharge (ESD) standard compliance for the BCM957412A4120AC Network Interface Card.

3.1 Regulatory

Table 2: Regulatory Approvals

Item	Applicable Standard	Approval (A)/Certificate (C)
CE/European Union	EN 62368-1:2014	CB report and certificate
UL/USA	IEC 62368-1 (ed. 2)	CB report and certificate

3.2 Safety

Table 3: Safety Approvals

Country	Certification Type/Standard	Compliance
International	CB Scheme ICES 003 - Digital Device UL 1977 (connector safety) UL 796 (PCB wiring safety) UL 94 (flammability of parts)	Yes

3.3 Electromagnetic Compatibility (EMC)

Table 4: Electromagnetic Compatibility

Standard/Country	Certification Type	Compliance
CE/EU	EN 55032:2012/2013 EN 55024:2010 EN 61000-3-2:2014 EN 61000-3-3:2013	CE report and CE DoC
FCC/USA	CFR47 Part 15 Subpart B	FCC/IC DoC and EMC report referencing FCC and IC standards
IC/Canada	ICES-003 Class B	FCC/IC DoC and report referencing FCC and IC standards
ACA/Australia, New Zealand	AS/NZS CISPR 22:2009 +A1:2010	ACA certificate RCM mark
BSM/Taiwan	CNS 13438 (2006)	BSMI certificate
BSMI/Taiwan	CNS 15663	BSMI certificate/RoHS table
MIC/S. Korea	RRL KN22 Class B KN24	Korea certificate MSIP mark
VCCI/Japan	VCCI V-3 (2015-04)	Copy of VCCI online certificate

3.4 Electrostatic Discharge (ESD) Compliance

Table 5: ESD Compliance Summary

Standard	Certification Type	Compliance
EN 55024:2010 (EN 61000-4-2)	Air/Direct discharge	Yes

3.5 FCC Statement

This equipment has been tested and found to comply with the limits for a Class B digital device, pursuant to Part 15 of the FCC Rules. These limits are designed to provide reasonable protection against harmful interference in a residential installation. This equipment generates uses and can radiate radio frequency energy and, if not installed and used in accordance with the instructions, may cause harmful interference to radio communications. However, there is no guarantee that interference will not occur in a particular installation. If this equipment does cause harmful interference to radio television reception, which can be determined by turning the equipment off and on, the user is encouraged to try to correct the interference by one or more of the following measures:

- Reorient or relocate the receiving antenna.
- Increase the separation between the equipment and receiver.
- Consult the dealer or an experienced radio/TV technician for help.

NOTE: Changes or modifications not expressly approved by the manufacturer responsible for compliance could void the user's authority to operate the equipment.

4 Board Power and Environmental Specifications

Table 6 provides the adapter power consumption.

Table 6: Adapter Power Consumption

Adapter Power ^a	Power Reduction ^b Disabled	Power Reduction Enabled
Media	Passive DAC Cable	Passive DAC Cable
Typical – 50% Ethernet traffic	7.9W	5.3W
Max – 100% Ethernet traffic	9.1W	6.5W

a. Power consumption of adapter at 55°C ambient temperature.

b. Reference the Broadcom Product Advisory PA-253336 for power reduction details or contact the Broadcom FAE for additional information.

Table 7 provides the adapter environmental specifications. The system designer may deploy methods to monitor the BCM57412 junction temperature (T_j) and provide sufficient airflow for keeping T_j below 105°C during normal operation.

Table 7: Adapter Environmental Specifications

Airflow	Ambient Temperature	10GBASE-T Network Cable
Hot Aisle	55°C	100 LFM
Storage Humidity	Relative Humidity Range (Non-condensing) maximum 90% at 35°C	
Storage Temperature	-40°C to 70°C	
Operating Temperature	0°C to 55°C	

5 Package Weight

Table 8 shows the BCM957412A4120AC package weight (excluding optical module).

Table 8: Package Weight

Parameter	Symbol	Value	Unit
BCM957412A4120AC weight	g	75	gram

6 Physical and Electrical Specifications

This section outlines the mechanicals of the BCM957412A4120AC network interface card as well as the Environmental Specifications.

6.1 Board Physical Dimensions

The BCM957412A4120AC board dimensions are shown in Figure 4. The dimensions are in inches with a tolerance of ± 0.005 .

Figure 4: Board Physical Dimensions

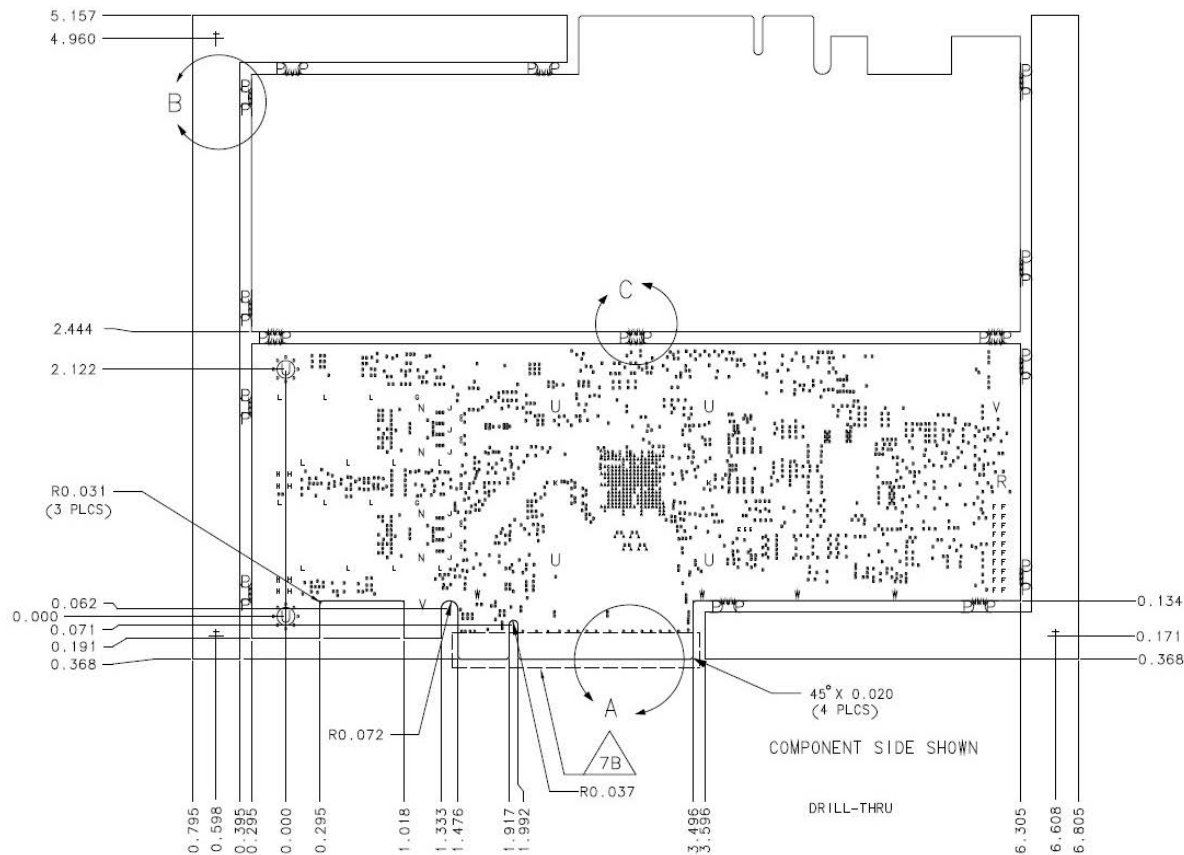

6.2 Bracket Outlines and Dimensions

The BCM957412A4120AC supports both a standard and low-profile bracket.

6.3 Standard-Profile Bracket Outline and Dimensions

The standard-profile bracket outline and physical dimensions are shown in [Figure 5](#).

Figure 5: Standard-Profile Bracket Outline and Dimensions

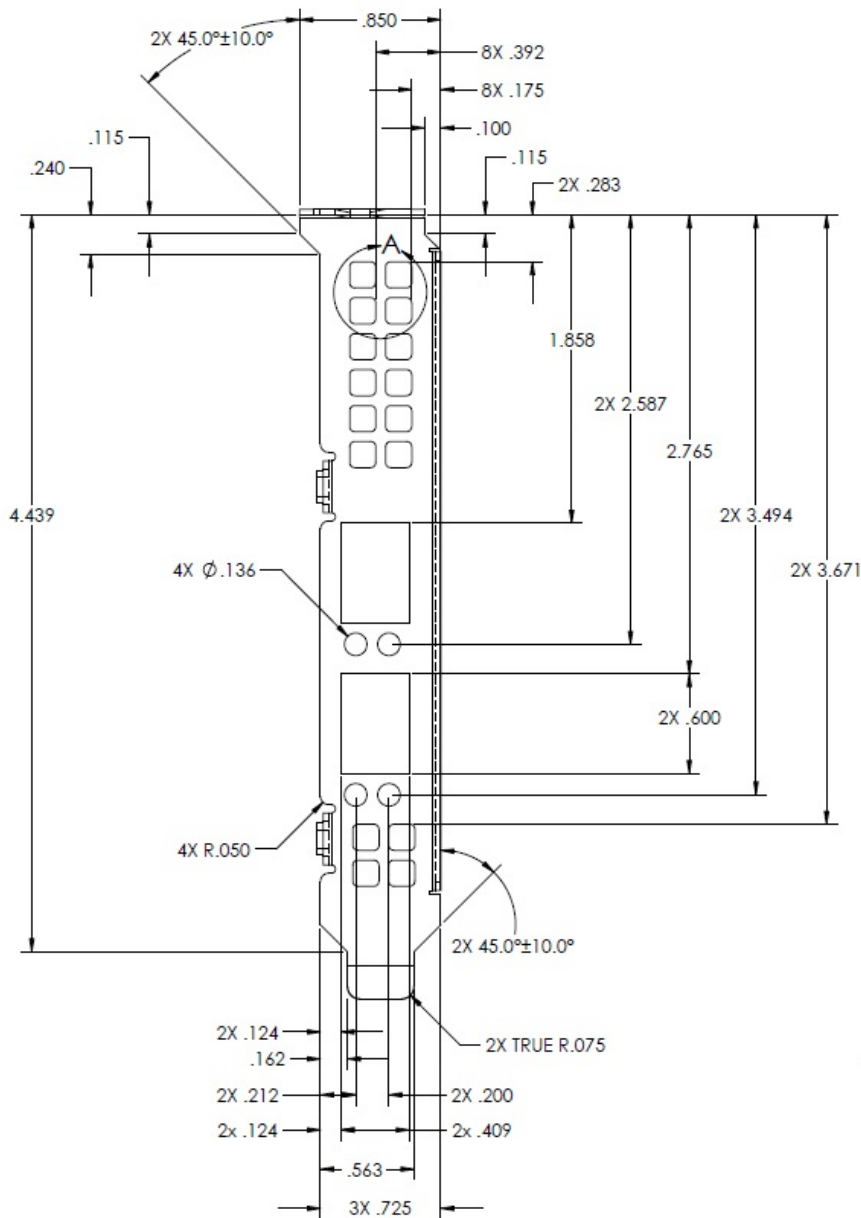

NOTE: [Figure 5](#) is only for mechanical dimensions and does not reflect the real marking of the bracket.

6.4 Low-Profile Bracket Outline and Dimensions

The low-profile bracket outline and physical dimensions are shown in Figure 6.

Figure 6: Low-Profile Bracket Outline and Dimensions

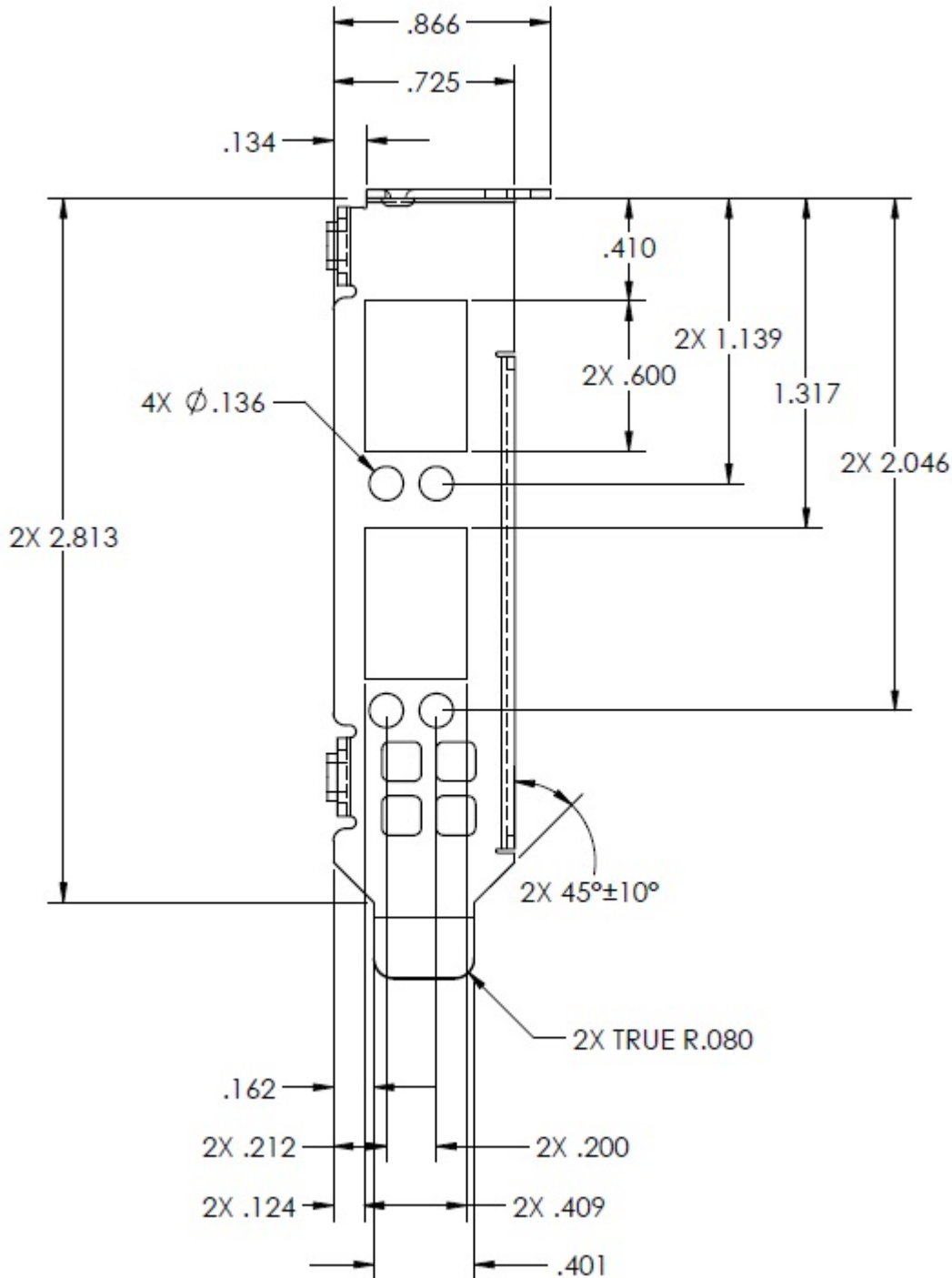

NOTE: Figure 6 is only for mechanical dimensions and does not reflect the real marking of the bracket.

7 Ordering Information

Table 9: Ordering Information

Part Number	Description
BCM957412A4120AC	Dual-Port 10 Gb/s SFP+ Ethernet PCI Express Network Interface Card; RoHS-compliant, Halogen-Free

Revision History

957412A4120AC-DS107; February 14, 2023

Added:

- Note below [Figure 3](#).
- Note below [Figure 5](#).

Updated:

- [Table 6, Adapter Power Consumption](#) – Updated column header to Passive DAC cable.

957412A4120AC-DS106; December 21, 2022

Added:

- Board Power and Environmental Specifications

957412A4120AC-DS105; March 15, 2022

Updated:

- SMBus Interface – Updated description.

957412A4120AC-DS104; November 3, 2020

Updated:

- Features – Added support for wake-on-LAN.
- Figure 1, BCM957412A4120AC Network Interface Card – Updated figure.
- Figure 2, BCM957412A4120AC Block Diagram – Updated block diagram.

957412A4120AC-DS103; July 9, 2020

Updated:

- Figure 3, Activity and Link LED Locations – Updated figure.

957412A4120AC-DS102; June 18, 2020

Updated:

- Figure 1, BCM957412A4120AC Network Interface Card – Updated figure.
- Figure 2, BCM957412A4120AC Block Diagram – Updated SFP to SFP+.

Added:

- Board Power Consumption
- Airflow Requirements
- Package Weight

957412A4120AC-DS101; December 26, 2017

- “Regulatory and Safety Approvals” on page 9

957412A4120AC-DS100; April 3, 2017

Initial Release

Broadcom, the pulse logo, Connecting everything, TruFlow, Avago Technologies, Avago, and the A logo are among the trademarks of Broadcom and/or its affiliates in the United States, certain other countries, and/or the EU.

Copyright © 2017 – 2023 Broadcom. All Rights Reserved.

The term “Broadcom” refers to Broadcom Inc. and/or its subsidiaries. For more information, please visit www.broadcom.com.

Broadcom reserves the right to make changes without further notice to any products or data herein to improve reliability, function, or design. Information furnished by Broadcom is believed to be accurate and reliable. However, Broadcom does not assume any liability arising out of the application or use of this information, nor the application or use of any product or circuit described herein, neither does it convey any license under its patent rights nor the rights of others.

