

HMMC-3040

20–43 GHz Double-Balanced Mixer and LO-Amplifier

Data Sheet

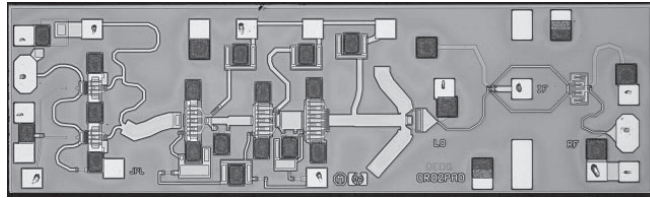

Chip Size:	2520 x 730 μm (99.2 x 28.7 mils)
Chip Size Tolerance:	$\pm 10 \mu\text{m}$ (± 0.4 mils)
Chip Thickness:	$127 \pm 15 \mu\text{m}$ (5.0 ± 0.6 mils)

Description

The HMMC-3040 is a broadband MMIC Double-Balanced Mixer (DBM) with an integrated high-gain LO amplifier. It can be used as either an up-converter or as a down-converter in microwave/ millimeter-wave transceivers. If desired, the LO amplifier can be biased to function as a frequency multiplier to enable harmonic mixing of a LO source.

This three-port device has input and output matching circuitry for use in 50 ohm environments. The MMIC provides repeatable conversion loss (requiring no tuning), thereby making it suitable for automated assembly processes.

Features

- Both up and downconverting functions
- Harmonic LO mixing capability
- Large bandwidth:
 - RF port: 20–43 GHz
 - LO port match: DC–43 GHz
 - LO amplifier: 20–43 GHz
 - IF port: DC–5 GHz
- Repeatable conversion loss: 9.5 dB typical at 30 GHz
- Low LO drive required
- 50 Ω port matching networks

Absolute Maximum Ratings^[1]

Symbol	Parameters/Conditions	Units	Min.	Max.
$V_{D1,2}$	Drain Supply Voltages	V		5
$V_{G1,2}$	Gate Supply Voltages	V	-3.0	0.5
I_{DD}	Total Drain Current	mA		400
P_{in}	RF Input Power	dBm		21
T_{ch}	Channel Temperature ^[2]	$^{\circ}\text{C}$		160
T_A	Backside Ambient Temperature	$^{\circ}\text{C}$	-55	+75
T_{st}	Storage Temperature	$^{\circ}\text{C}$	-65	+165
T_{max}	Max. Assembly Temperature	$^{\circ}\text{C}$		300

Notes:

1. Absolute maximum ratings for continuous operation unless otherwise noted.
2. Refer to DC Specifications/Physical Properties table for derating information.

HMMC-3040 DC Specifications/Physical Properties^[1]

Symbol	Parameters and Test Conditions	Units	Min.	Typ.	Max.
$V_{D1,2}$	Drain Supply Operating Voltages	V	2	4.5	5
I_{D1}	First Stage Drain Supply Current ($V_{DD} = 4.5\text{ V}$, $V_{G1} \cong -0.8\text{ V}$)	mA		27	
I_{D2}	Total Drain Supply Current for Stage 2 ($V_{DD} = 4.5\text{ V}$, $V_{GG} \cong -0.8\text{ V}$)	mA		123	
$V_{G1,2}$	Gate Supply Operating Voltages ($I_{DD} \cong 150\text{ mA}$)	V		-0.8	
V_P	Pinch-off Voltage ($V_{DD} = 4.5\text{ V}$, $V_{DD} \leq 10\text{ mA}$)	V	-2	-1.2	-0.8
θ_{ch-bs}	Thermal Resistance (Channel-to-Backside at $T_{ch} = 160^\circ\text{C}$) ^[2]	$^\circ\text{C}/\text{Watt}$		62	
T_{ch}	Channel Temperature ($T_A = 75^\circ\text{C}$, $\text{MTTF} > 10^6\text{ hrs}$, $V_{DD} = 4.5\text{ V}$, $I_{DD} = 300\text{ mA}$) ^[3]	$^\circ\text{C}$		160	

Notes:

- Backside ambient operating temperature $T_A = 25^\circ\text{C}$, unless otherwise noted.
- Thermal resistance ($^\circ\text{C}/\text{Watt}$) at a channel temperature $T(^\circ\text{C})$ can be *estimated* using the equation: $\theta(T) \cong 62x [T(^\circ\text{C})+273]/[160^\circ\text{C}+273]$.
- Derate MTTF by a factor of two for every 8°C above T_{ch} .

RF Specifications ($T_A = 25^\circ\text{C}$, $Z_0 = 50\ \Omega$, $V_{DD} = 4.5\text{ V}$, $I_{DD} = 150\text{ mA}$)

Symbol	Parameters and Test Conditions		Units	Min.	Typ.	Max.
BW	Operating Bandwidth	RF and LO	GHz	20	20–43	43
		IF	GHz	DC	DC–5	5
C.L.	Conversion Loss		dB		9.5	12
P_{LO}	LO Drive Level		dBm		2	
LO/RF Isolation	LO-to-RF Isolation ^[1]		dB		18	
P_{-1dB}	Input Power (@ 1 dB increase in C.L.)	Down-Convert (RF/IF)	dBm		15	
		Up-Convert (IF/RF)	dBm		8	

Note:

- Reference: LO input. Does not include LO amplifier gain (-20dB).

Applications

The HMMC-3040 MMIC is a broadband double-balanced mixer (DBM) with an integrated LO amplifier. It can be used as either a frequency up-converter or down-converter. This mixer was designed specifically for microwave/millimeter-wave point-to-point and point-to-multipoint (including LMDS/LMCS/MVDS) communication systems that operated in the 20–43 GHz frequency range.

The LO amplifier can also be biased to provide frequency multiplication of the LO source (Figure 2). The integrated LO amplifier will provide a good impedance match to low frequency input signals. Frequencies below approximately 18 GHz will not be passed by the LO network, enhancing LO rejection.

Biasing and Operation

The recommended DC bias condition is with all drains connected to a single 3.5–4.5 volt supply and all gates connected to an adjustable negative voltage supply. The gate voltage is adjusted for a total drain supply current of typically 150–230 mA. An assembly diagram is shown in Figure 4.

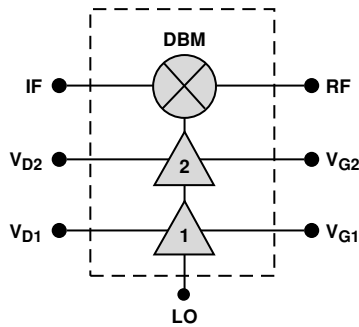

Figure 1. HMMC-3040 Simplified Block Diagram.

The LO amplifier has effectively two gain stages as indicated in Figure 1. One wire connection is needed to each DC drain bias supply pad, V_{D1} and V_{D2} , and one to each DC gate bias pad, V_{G1} and V_{G2} .

Harmonic LO mixing is possible in some limited cases. The integrated LO amplifier's stages can be individually biased to provide optimum harmonic output. When considering the HMMC-3040 as a harmonic mixer, it is important to realize that the integrated double balanced mixer diodes need ~18 dBm (15 to 22 dBm) to obtain optimum mixer conversion. Avago product note #15, "HMMC-3040 Multiplier Operation" provides two examples of harmonic mixing. Also, Avago application note #50, "HMMC-5040 As a 20 to 40 GHz Multiplier" provides additional information on multiplier operation and is a good reference when considering the HMMC-3040 as a harmonic mixer; the HMMC-3040 integrated LO amplifier is similar to the HMMC-5040. No impedance matching network is needed because the LO port provides a good match to signals having frequency from DC to approximately 43 GHz.

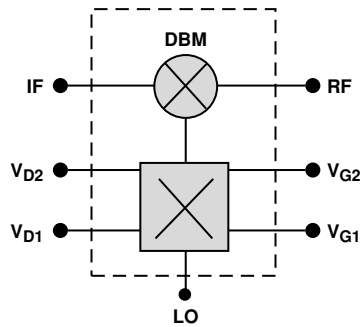

Figure 2. HMMC-3040 Harmonic Mixing Block Diagram.

The microwave/millimeter-wave ports are not AC-coupled. A DC blocking capacitor is required on any RF port that may be exposed to DC voltages.

No ground wires are needed because ground connections are made with plated through-holes to the backside of the device.

Assembly Techniques

It is recommended that the electrical connections to the bonding pads be made using 0.7-1.0 mil diameter gold wire. The microwave/millimeter-wave connections should be kept as short as possible to minimize inductance. For assemblies requiring long bond wires, multiple wires can be attached to the RF bonding pads.

GaAs MMICs are ESD sensitive. ESD preventive measures must be employed in all aspects of storage, handling, and assembly. MMIC ESD precautions, handling considerations, die attach and bonding methods are critical factors in successful GaAs MMIC performance and reliability.

Avago application note #54, "GaAs MMIC ESD, Die Attach and Bonding Guidelines" provides basic information on these subjects.

Additional References

PN #15, "HMMC-5040 Multiplier Operation," and AN # 50, "HMMC-5040 As a 20-40 GHz Multiplier."

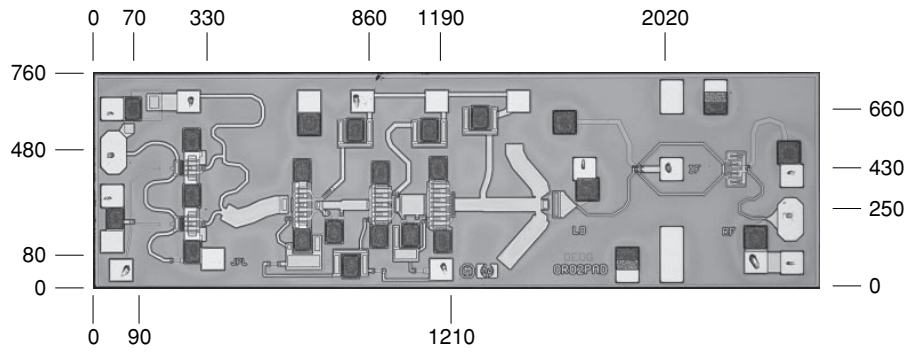

Note:

1. Numbers relate to (X,Y) reference. (Dimensions are micrometers)

Figure 3. HMMC-3040 Bonding Pad Positions.

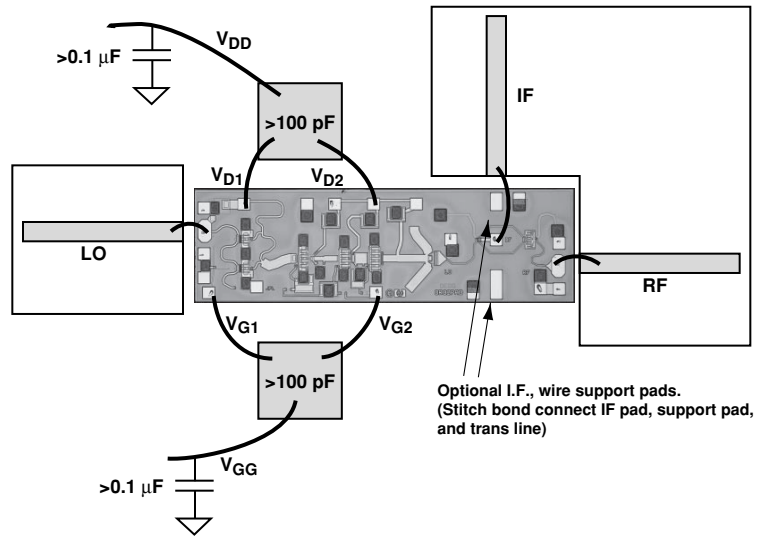

Figure 4. HMMC-3040 Common Assembly Diagram.

Additional HMMC-3040 Performance Characteristics
(Data refer to Figure 1)

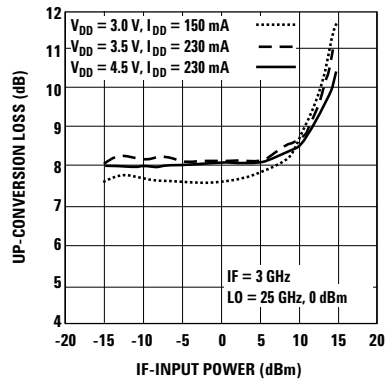

Figure 5. Up-Conversion Loss vs. IF Input Power for Various LO Amplifier Bias Conditions.

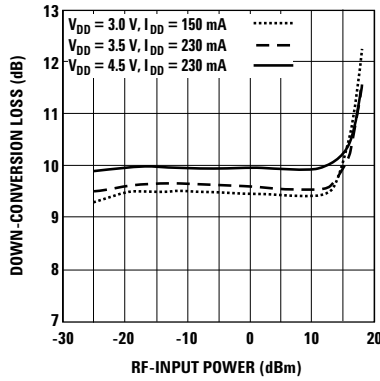

Figure 6. Down-Conversion Loss vs. RF Input Power.

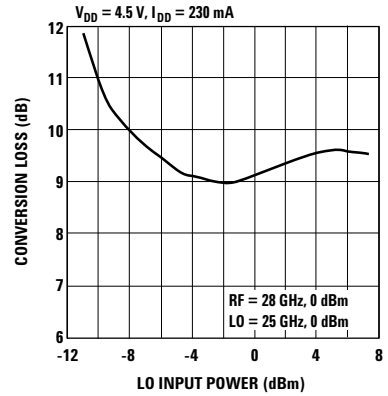

Figure 7. Conversion Loss vs. LO Input Power.

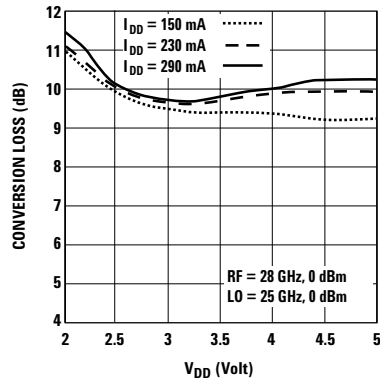

Figure 8. Conversion Loss vs. V_{DD} for Various LO Amplifier Drain Currents.

Note:

All data measured on individual devices mounted in a 50 GHz test package $T_A = 25^\circ\text{C}$ and under Figure 1 condition (except where noted).

This data sheet contains a variety of typical and guaranteed performance data. The information supplied should not be interpreted as a complete list of circuit specifications. In this data sheet the term *typical* refers to the 50th percentile performance. For additional information contact your local Avago Technologies' sales representative.

For product information and a complete list of distributors, please go to our web site:
www.avagotech.com

Avago, Avago Technologies, and the A logo are trademarks of Avago Technologies, Limited in the United States and other countries.
 Data subject to change. Copyright © 2006 Avago Technologies, Limited. All rights reserved.
 Obsoletes 5988-1906EN
 5988-6895EN September 16, 2006

