

Broadcom BCM5720 Controller Technology

Connecting everything®



X2 PCI EXPRESS® DUAL-PORT GIGABIT ETHERNET CONTROLLER

Overview

The Broadcom® BCM5720 is a thirteenth-generation 10/100/1000BASE-T Ethernet LAN controller solution suitable for high-performance server applications.

Built on proven architecture, the BCM5720 provides a PCI Express® v2.0-compliant host interface, which can operate at 5 GT/s or at 2.5 GT/s at x2 link width. The PCI Express supports MSI and MSI-X capabilities and Function Level Reset (FLR).

The BCM5720 combines dual triple-speed IEEE 802.3™-compliant Media Access Controllers (MACs) with dual 1000BASE-X/SGMII SerDes transceivers or dual 10/100/1000 Ethernet transceivers (PHYs), selectable individually per port, a Network Controller Sideband Interface (NC-SI), and on-chip memory buffer in a single device.

Device Features

- Integrated dual 10/100/1000BASE-T and dual 1000BASE-X/SGMII 1.25 Gbaud SerDes transceivers.
- Energy Efficient Ethernet™ (EEE) compliant with IEEE Std 802.3az-2010
- Dual 10/100/1000BASE-T full-duplex/half-duplex MACs
- Dual 1000BASE-X/SGMII full-duplex/half-duplex MACs
- Automatic MDI crossover
- x2 PCI Express v2.0 at 5 GT/s or 2.5 GT/s
- MSI and MSI-X capabilities—up to 17 MSI-X vectors
- I/O Virtualization (IOV) support for VMWare® NetQueue and Microsoft® VMQ
- 17 receive queues and 16 transmit queues
- 17 MSI-X vectors supporting per queue interrupt to host
- Flexible MSI-X vector to transmit/receive queue association
- TLP Processing Hint (TPH) ECN to the PCI Express Base Specification v2.0

- Function level reset
- Receive Side Scaling (RSS) with per queue MSI-X vector support and support for UDP RSS hash type
- Transmit Side Scaling (TSS) and multi-Tx queue with per queue MSI-X vector support
- Jumbo frame support for up to 9600-byte payload
- Virtual LAN (VLAN) support—IEEE 802.1q VLAN tagging
- TCP, IP, UDP checksum offload
- Large Send Offload (LSO), TCP Segmentation Offload (TSO)
- Hardware assist for IEEE 1588 and IEEE 802.1AS time synchronization implementations
- IEEE 802.3x flow control
- SMBus 2.0 Interface
- Statistics for SNMP MIB II, Ethernet-like MIB and Ethernet MIB (IEEE 802.3z, Clause 30)
- ACPI power management compliance
- Advanced power management by a Central Power Management Unit (CPMU)
- Efficient integrated switching regulator controller
- Host to/from BMC (H2B) Pass Through
- On-chip temperature monitor
- PCI Express CLKREQ support
- Power Management Offload (PM Offload)
- Serial flash and EEPROM NVRAM support; flash autoconfigure
- ECC error detection and correction on internal SRAM
- JTAG boundary scan support
- 169-ball FBGA (1.0 mm pitch)

Target Applications

- LAN on motherboard (LOM) for servers and workstations
- PCI Express Gigabit Ethernet add-in NIC
- Blade servers with Ethernet over electrical backplane

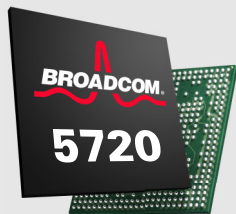

Highlights

- Energy Efficient Ethernet support
- Hardware support for IEEE 1588 timestamping
- Host to BMC connectivity for better system manageability

	BCM5720
1G	●
10G	
NetXtreme® I	●
NetXtreme II®	
Ports	Dual

○ Supported

● Best Choice

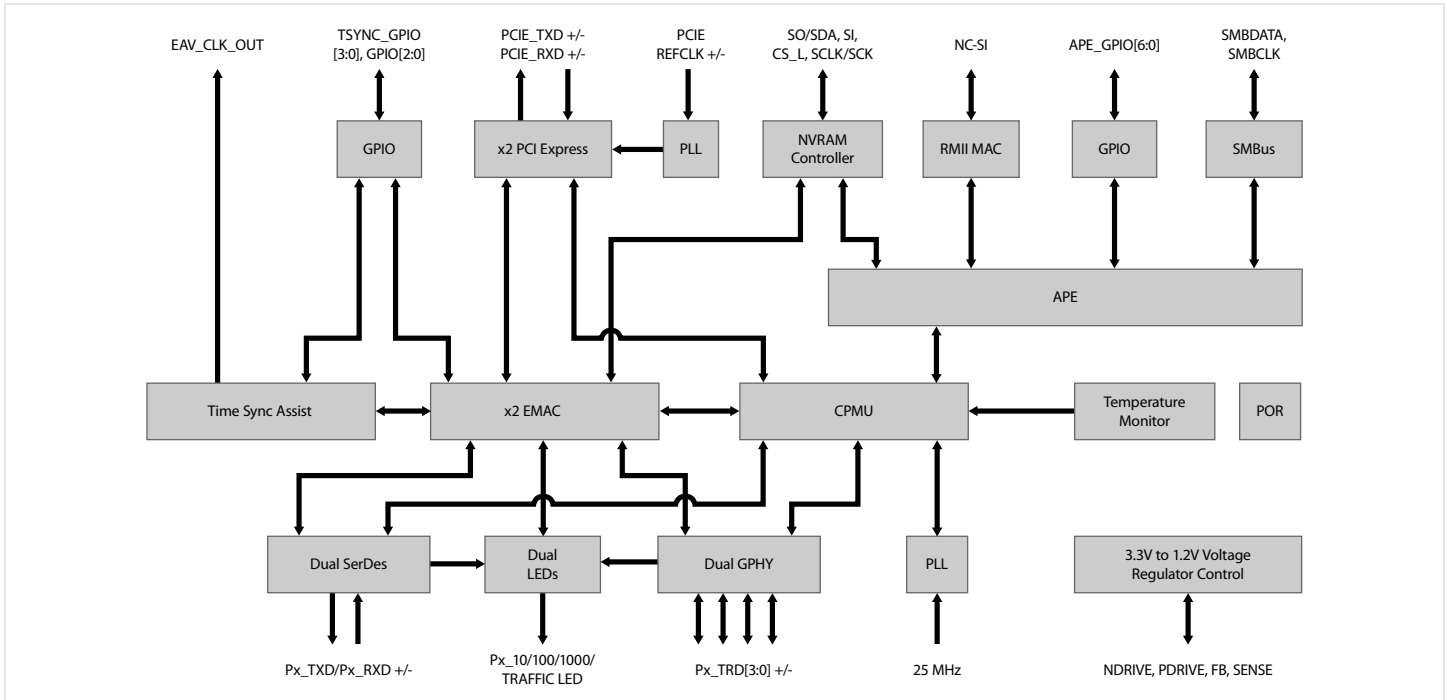

BCM5720 Block Diagram

The host interface supports a separate PCI Express function for each LAN interface. The BCM5720 includes I/O Virtualization features such as 17 receive and 16 transmit queues, 17 MSI-X vectors with flexible vector-to-queue association. These IOV features enable the BCM5720 to support the VMWare NetQueue and Microsoft VMQ technologies.

The BCM5720 includes a comprehensive set of hardware features that the system may use to implement IEEE 1588- or IEEE

802.1AS-based time synchronization. These hardware features include a high-precision clock, timestamp registers for receive/transmit packets, and programmable trigger inputs and watchdog outputs.

The BCM5720 is fabricated in a low-voltage 65 nm CMOS process and integrates an efficient switching voltage regulator controller for core power supplies. Advanced power management features built into the BCM5720 enable minimiz-

ing the power consumption of the network controller subsystem by lowering the controller's power consumption under lighter network traffic without compromising performance. The BCM5720 implements Energy Efficient Ethernet (EEE) compliance with the IEEE Std 802.3az-2010, which further reduces the power consumption with idle 100 Mbit or 1 Gbit GHY links. These features provide a low power consumption Ethernet controller solution.

Ordering Information

Package	Ambient Temperature	Part Number
169-ball FBGA (14 mm x 14 mm, lead-free)	0°C to 55°C	BCM5720A0KFBG

About Broadcom

Broadcom Corporation (NASDAQ: BRCM), a FORTUNE 500® company, is a global leader and innovator in semiconductor solutions for wired and wireless communications. Broadcom® products seamlessly deliver voice, video, data, and multimedia connectivity in the home,

office, and mobile environments. With the industry's broadest portfolio of state-of-the-art system-on-a-chip and embedded software solutions, Broadcom is changing the world by Connecting everything®. For more information, go to www.broadcom.com.

