



Brocade DCX 8510-8 Backbone Hardware Installation Guide

Hardware Installation Guide
2 June 2020

Copyright © 2020 Broadcom. All Rights Reserved. Broadcom, the pulse logo, Brocade, the stylized B logo, Fabric OS, and SANnav are among the trademarks of Broadcom in the United States, the EU, and/or other countries. The term “Broadcom” refers to Broadcom Inc. and/or its subsidiaries.

Broadcom reserves the right to make changes without further notice to any products or data herein to improve reliability, function, or design. Information furnished by Broadcom is believed to be accurate and reliable. However, Broadcom does not assume any liability arising out of the application or use of this information, nor the application or use of any product or circuit described herein, neither does it convey any license under its patent rights nor the rights of others.

The product described by this document may contain open source software covered by the GNU General Public License or other open source license agreements. To find out which open source software is included in Brocade products, to view the licensing terms applicable to the open source software, and to obtain a copy of the programming source code, please download the open source disclosure documents in the Broadcom Customer Support Portal (CSP). If you do not have a CSP account or are unable to log in, please contact your support provider for this information.

Table of Contents

About This Document.....	9
What's new in this document.....	9
Supported hardware and software.....	9
Notes, Cautions, and Danger Notices.....	9
Contacting Technical Support for Your Brocade® Product.....	9
Document Feedback.....	10
Product Overview.....	11
Product features.....	11
Hardware components.....	11
Port side view of the device.....	13
Nonport side view of the device.....	14
Supported blades.....	14
Chassis slots numbering.....	16
Port numbering.....	16
High availability.....	17
Reliability.....	17
Serviceability.....	18
Software features.....	18
Security.....	19
Network manageability.....	19
Preparing for the Installation.....	21
Installation and safety considerations.....	21
Time and items required.....	22
Items included with the device.....	23
Mounting the Device.....	24
Mounting options.....	24
Mounting precautions.....	24
Unpacking, transporting, and installing the device.....	25
Installing the 14U Rack Mount Kit for Four-Post Racks (XBR-DCX-0120 and XBR-DCX-0152).....	26
Time and Items Required.....	26
Parts List.....	26
Parts List – NEBS Kit.....	28
Assembling the rack hardware.....	29
Installing the device in the rack.....	32
Installing the 14U Chassis Mid-Mount Rack Kit for Two-Post Racks (XBR-DCX-0121).....	33
Time and Items Required.....	34

Parts List.....	34
Assembling the Rack Hardware.....	36
Installing the device in the rack.....	37
Cable Management.....	40
Requirements and precautions.....	40
Cable types supported on the FC16-64 port blade.....	40
Installing inter-chassis links (ICLs).....	41
Possible ICL configurations.....	43
Using Brocade 2 km LWL QSFPs.....	46
Qualified cables for the FC8-64 port blade.....	47
High-density cabling for the FC8-64 port blade.....	48
Initial Configuration.....	50
Items required.....	50
Providing power to the device.....	50
Configuring the device.....	51
Establishing a serial connection to the device.....	52
Logging in to the serial console port.....	53
Configuring the IP addresses.....	54
Logging off the serial console port and disconnecting the serial cable.....	55
Establishing an Ethernet connection to the device.....	56
Customizing a switch name.....	56
Customizing a chassis name.....	56
Setting the domain ID.....	57
Setting the date and time.....	57
Setting the date.....	57
Setting the time zone.....	58
Synchronizing local time.....	58
Determining installed software licenses.....	59
Installing transceivers and attaching cables.....	59
Installing SFP+ and mSFP transceivers and cables.....	59
Qualified transceivers for the FC16-64 and CR16-x blades.....	60
Installing QSFP transceivers and cables.....	60
Managing Cables.....	62
Verifying correct operation and backing up the configuration.....	63
Powering off the chassis.....	64
System Monitoring.....	65
Monitoring overview.....	65
Determining the status of a port, application, or extension blade.....	72
FC8-32E port blade LEDs.....	73

FC8-48E port blade LEDs.....	74
FC8-64 port blade LEDs.....	75
FC16-32 port blade LEDs.....	76
FC16-48 port blade LEDs.....	77
FC16-64 port blade LEDs.....	78
FCOE10-24 FCoE blade LEDs.....	79
FS8-18 encryption blade LEDs.....	80
FX8-24 extension blade LEDs.....	81
Port, application, and extension blade power LED description.....	81
Port blade status LED description.....	82
FC ports status LED description.....	82
GbE and 10-GbE ports status LED description.....	83
Determining the status of a control processor blade (CP8).....	84
Determining the status of a core switch blade (CR16-8).....	86
Determining the status of a power supply.....	87
Determining the status of a blower assembly.....	88
Determining the status of a WWN card.....	90
Managing Cables.....	93
Removal and Replacement Procedures.....	94
Introduction.....	94
ESD precautions.....	94
Chassis door removal and replacement.....	94
Time and items required.....	94
Removing a chassis door.....	94
Replacing a chassis door.....	95
Cable management comb removal and replacement.....	95
Time and items required.....	95
Removing a cable management comb.....	96
Replacing a cable management comb.....	97
Port and application blade removal and replacement.....	97
Time and items required.....	97
Removing a blade.....	98
Replacing a blade.....	99
Blade filler panel removal and replacement.....	100
Blade filler panel removal and replacement.....	100
Removing a filler panel.....	100
Replacing a filler panel.....	102
Control processor blade (CP8) removal and replacement.....	102
Time and items required.....	102

Faulty CP blade indicators.....	102
Recording critical device information.....	103
Power-up procedure.....	104
Removing a control processor blade (CP8).....	104
Replacing a control processor blade (CP8).....	105
Power-down procedure.....	106
Verifying operation of the new CP blade.....	107
Downloading firmware from an FTP server.....	108
Downloading firmware from a USB device.....	110
Completing the replacement.....	114
Core switch blade (CR16-x) removal and replacement.....	115
Time and items required.....	115
Faulty core switch blade indicators.....	115
Removing a core switch blade (CR16-x).....	115
Replacing a core switch blade (CR16-x).....	117
Power supply removal and replacement.....	117
Time and items required.....	118
Identifying power supplies.....	118
Removing a power supply.....	118
Replacing a power supply.....	120
Blower assembly removal and replacement.....	120
Time and items required.....	120
Removing a blower assembly.....	121
Replacing a blower assembly.....	122
WWN card removal and replacement.....	122
Time and items required.....	122
Using the wwnrecover utility.....	123
Verifying the need for replacement.....	123
Preparing for WWN card replacement.....	124
Hot-swap replacement.....	124
Power-down replacement.....	125
Removing the WWN card and WWN bezel (logo plate).....	127
Transceiver and fiber optic cable removal and replacement.....	130
Time and items required.....	131
Items required.....	131
Removing an SFP+ transceiver.....	131
Replacing an SFP+ transceiver.....	132
Removing and replacing an mSFP optical transceiver and cable.....	133
Removing an mSFP transceiver.....	133
Replacing an mSFP transceiver.....	133

Removing and replacing a QSFP and cable.....	133
Qualified transceivers for the FC16-64 and CR16-x blades.....	134
Removing a QSFP transceiver and cable.....	134
Replacing a QSFP transceiver and cable.....	135
Chassis removal and replacement.....	136
Time and items required.....	136
Faulty chassis indicators.....	137
Recording critical device and SAN information.....	137
Disconnecting from network and fabric.....	141
Removing components from the chassis.....	141
Installing the replacement chassis.....	142
Installing components into the chassis.....	142
Downloading the configuration.....	143
Reconnecting the system to the network and fabric.....	144
Verifying correct operation of system.....	145
Verifying correct configuration of the fabric.....	146
Cable routing table.....	147
Diagnostics and Troubleshooting.....	150
Introduction.....	150
Obtaining chassis and component status.....	150
Interpreting POST and boot results.....	151
POST.....	151
Boot.....	151
Diagnostics.....	151
Troubleshooting.....	152
Application and Encryption Blades.....	155
Introduction.....	155
FS8-18 blade.....	155
FX8-24 blade.....	155
FCOE10-24 blade.....	156
Limitations of FCOE10-24 blade.....	157
Port Numbering Templates.....	158
CR16-8 core blade port numbering.....	158
FC8-32E port blade port numbering.....	159
FC8-48E port blade port numbering.....	160
FC8-64 port blade port numbering.....	161
FC16-32 port blade port numbering.....	162
FC16-48 port blade port numbering.....	163
FC16-64 port blade port numbering.....	164

FCOE10-24 FCoE blade port numbering.....	165
FS8-18 encryption blade port numbering.....	166
FX8-24 extension blade port numbering.....	167
Regulatory Statements.....	168
BSMI Statement (Taiwan).....	168
Canadian Requirements.....	168
CE Statement.....	168
China ROHS.....	169
FCC Warning (U.S. Only).....	169
Germany statement.....	169
KCC Statement (Republic of Korea).....	169
VCCI Statement.....	170
Caution and Danger Notices.....	171
Cautions.....	171
Danger Notices.....	172
Revision History.....	175

About This Document

What's new in this document

Starting with this release, all new and modified content is listed in the "Revision History" section at the end of this document.

Supported hardware and software

This document includes information specific to the Brocade DCX 8510-8 running Brocade Fabric OS version 7.4.0 and later.

Notes, Cautions, and Danger Notices

Notes, cautions, and danger statements may be used in this document.

NOTE

A Note provides a tip, guidance, or advice, emphasizes important information, or provides a reference to related information.



CAUTION

A Caution statement alerts you to situations that can be potentially hazardous to you or cause damage to hardware, firmware, software, or data.



DANGER

A Danger statement indicates conditions or situations that can be potentially lethal or extremely hazardous to you. Safety labels are also attached directly to products to warn of these conditions or situations.

Contacting Technical Support for Your Brocade[®] Product

For product support information and the latest information on contacting the Technical Assistance Center, go to <https://www.broadcom.com/support/fibre-channel-networking/>. If you have purchased Brocade[®] product support directly from Broadcom, use one of the following methods to contact the Technical Assistance Center 24x7.

Online	Telephone
<p>For nonurgent issues, the preferred method is to log in to myBroadcom at https://www.broadcom.com/mybroadcom. (You must initially register to gain access to the Customer Support Portal.) Once there, select Customer Support Portal > Support Portal. You will now be able to navigate to the following sites:</p> <ul style="list-style-type: none"> • Knowledge Search: Clicking the top-right magnifying glass brings up a search bar. • Case Management: The legacy MyBrocade case management tool (MyCases) has been replaced with the Fibre Channel Networking case management tool. • DocSafe: You can download software and documentation. • Other Resources: Licensing Portal (top), SAN Health (top and bottom), Communities (top), Education (top). 	<p>Required for Severity 1 (critical) issues: Please call Fibre Channel Networking Global Support at one of the numbers listed at https://www.broadcom.com/support/fibre-channel-networking/.</p>

If you purchased Brocade product support from a Broadcom OEM/solution provider, contact your OEM/solution provider for all your product support needs.

- OEM/solution providers are trained and certified by Broadcom to support Brocade products.
- Broadcom provides backline support for issues that cannot be resolved by the OEM/solution provider.
- Brocade Supplemental Support augments your existing OEM support contract, providing direct access to Brocade expertise. For more information on this option, contact Broadcom or your OEM.
- For questions regarding service levels and response times, contact your OEM/solution provider.

Document Feedback

Quality is our first concern. We have made every effort to ensure the accuracy and completeness of this document. However, if you find an error or an omission or if you think that a topic needs further development, we want to hear from you. Send your feedback to documentation.pdl@broadcom.com. Provide the publication title, publication number, topic heading, page number, and as much detail as possible.

Product Overview

Product features

Key product features include the following:

- Up to 512 16-Gbps external ports in a single chassis , enabling high density SAN configurations with reduced footprint.
- Support for 2, 4, 8, and 16-Gbps autosensing Fibre Channel ports. Trunking technology groups up to eight ports to create high performance 128-Gbps ISL trunks between switches.
- 10-Gbps FC-type SFPs in 32/48-port 16-Gbps port blades, and 10-GbE SFPs in the FX8-24 and FCOE10-24 application blades . The two types of SFPs are not interchangeable.
- The 10-Gbps ports can be manually configured on any port of the 32- and 48-port 16-Gbps port blades.
- Support for many of the application, port blade, and control processor (CP) blades supported in the Brocade DCX family of backbones (with the exception of the Core Switch Blade), thereby providing flexible system configurations and fewer types of new blades.
- Beginning with Fabric OS v7.0.1, up to nine chassis can be connected with the use of 4x16-Gbps quad SFP (QSFP) inter-chassis links (ICLs). Fabric OS v7.0.0 permits up to six chassis to be linked.
- Support for high-performance port blades running at 2, 4, 8, 10, or 16-Gbps, enabling flexible system configuration.
- Redundant and hot-swappable control processor and core switch blades, power supplies, blower assemblies, and WWN cards that enable a high availability platform and enable nondisruptive software upgrades for mission-critical SAN applications.
- Universal ports that self-configure as E_Ports, F_Ports, EX_Ports and M_Ports (mirror ports). 10-Gbps ports are E_Ports only.
- Diagnostic port (D_Port) functionality.
- In-flight data cryptographic (encryption/decryption) and data compression capabilities through the 16-Gbps port blades when configured as ISLs.
- Fibre Channel over IP (FCIP) functionality through the FX8-24 blade.
- Fibre Channel over Ethernet (FCoE) capability through the FCOE10-24 blade.

Hardware components

The device has a modular and scalable mechanical construction that allows a wide range of flexibility in installation, fabric design, and maintenance. The chassis can be mounted with the cables facing the front of the equipment rack or to the rear, and consists of the following:

- Up to eight hot-swappable port blade assemblies that can be configured in a single chassis, delivering up to 512 16-Gbps Fibre Channel ports .
- Two slots for control processor blades (CP8):
 - A single active CP8 blade can control all the ports in the chassis.
 - The standby CP8 blade assumes control of the chassis if the active CP fails.
 - The CP blade contains the control plane for the device and hosts the Fabric OS that manages all hardware within the device.

The CP blade provides the following external connections for device configuration, firmware downloads, service, management, and monitoring functions.

- USB port for firmware download and `supportsave data`.
- Serial console RJ45 port.
- An 10/100/1000Base-T RJ45 Ethernet port for device management and configuration. This is an auto-sensing MDI port.
- An 10/100/1000Base-T RJ45 Ethernet port for service. This is an auto-sensing MDI port.

NOTE

Device control processors and management modules contain batteries for RTC/NVRAM backup. Do not attempt to replace these batteries. Dispose of hardware components containing these batteries as required by local ordinances and regulations.

- Two slots for core switch blades (CR16-8):
 - CR16-8 blade interconnects all port blades.
 - Inter-chassis link (ICL) connectors to connect to as many as nine neighboring chassis using Fabric OS v7.0.1 or later. Only six chassis can be connected using Fabric OS v7.0.0.
 - Both CR16-8 blades are active.
- Modular, hot-swappable port blades:
 - 32-port, 8-Gbps blades (FC8-32E)
 - 48-port, 8-Gbps blades (FC8-48E)
 - 64-port, 8-Gbps blades (FC8-64)
 - 32-port, 16-Gbps blades (FC16-32)
 - 48-port, 16-Gbps blades (FC16-48)
 - 64-port, 16-Gbps blades (FC16-64)
- Modular, hot-swappable application blades:
 - FX8-24: 24-port (12 FC, 10 1-GbE, and 2 10-GbE) FCIP extension blade enabling long distance communication over existing IP infrastructure.
 - FCOE10-24: 24-port (24 10-GbE) CEE-based FCoE blade enabling enhanced connectivity using existing Ethernet infrastructure. The FCoE blade can be used in the same chassis with only the FC8-32E and FC16-32 port blade. The FCoE blade cannot be used with any other FC port or application blades in the same chassis.
- Modular, hot-swappable encryption blades:
 - FS8-18: 16-port, up to 4 blades per chassis, supporting in-flight data cryptographic (encryption/decryption) and data-compression capabilities.
- Modular, hot-swappable field-replaceable units (FRUs):
 - Three blower assemblies.
 - Up to four power supplies (100-240 VAC autosensing).
 - At 110 VAC (nominal): Four power supplies are required for high availability.
 - 220 VAC (nominal) is recommended for efficiency. Two or four power supplies are provided depending on the quantity ordered. Refer to the power specifications section in the *Brocade DCX 8510 Backbone Technical Specification* for specific requirements for high availability.
 - Redundant AC primary power connections ensure high availability. Each power supply has its own connector, so the number of primary power connections is four for optimum efficiency and redundancy.
 - Two WWN cards.
 - Blades use small form-factor pluggable (SFP+, mSFP, and QSFP) optical transceivers.

- The 8-Gbps SFP+s and mSFPs auto-negotiate at 2, 4, and 8 Gbps.
 - The 10-Gbps speed must be manually set and requires special 10-Gbps FC SFP+ transceivers.
 - The 16-Gbps SFP+ transceivers support speeds of 2, 4, 8, 10, and 16 Gbps.
 - The 16-Gbps QSFPs supported on FC16-64 port blade and core blades auto-negotiate at 4, 8, and 16 Gbps.
 - The 16-Gbps fixed-speed QSFPs on the core blades run at 64-Gbps (four fixed 16-Gbps clustered in a single quad connector and cable).
- Blades are serviced from the port side of the chassis. Blowers, power supplies, and power cables are serviced from the nonport side.
 - World Wide Name (WWN) cards with status LEDs on the nonport side.
 - Redesigned cable management comb and chassis door.

Port side view of the device

Figure 1: Port side of the Brocade DCX 8510-8 (sample configuration)

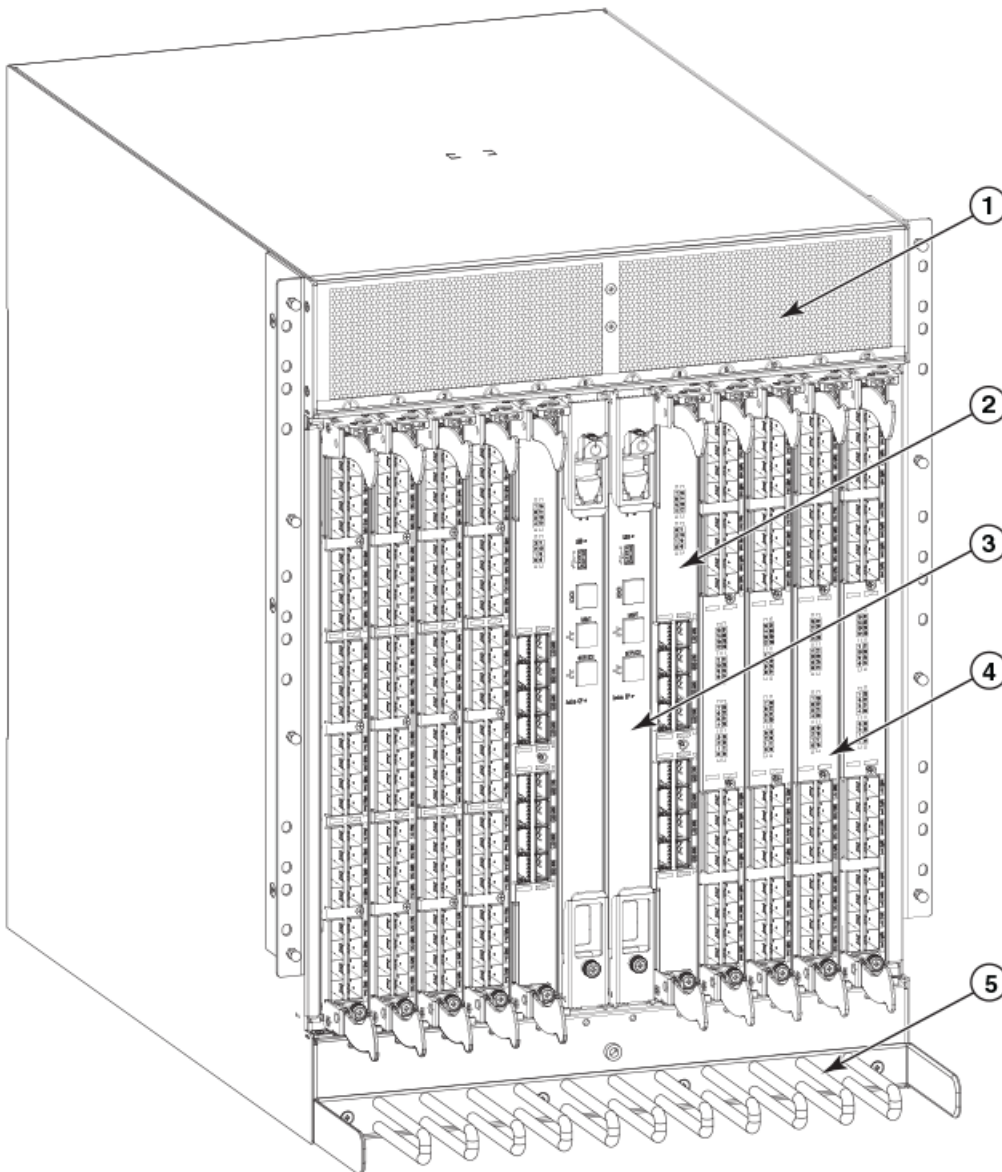

1. Exhaust vent

2. Core switch blade (CR16-8)
3. Control processor blade (CP8)
4. FC16-32 port blade
5. Cable management comb

NOTE

Airflow is from the nonport side to the port side and out the exhaust vent.

Nonport side view of the device

The following figure shows a sample configuration of the nonport side view of the Brocade DCX 8510-8.

Figure 2: Nonport side of the Brocade DCX 8510-8 (sample configuration)

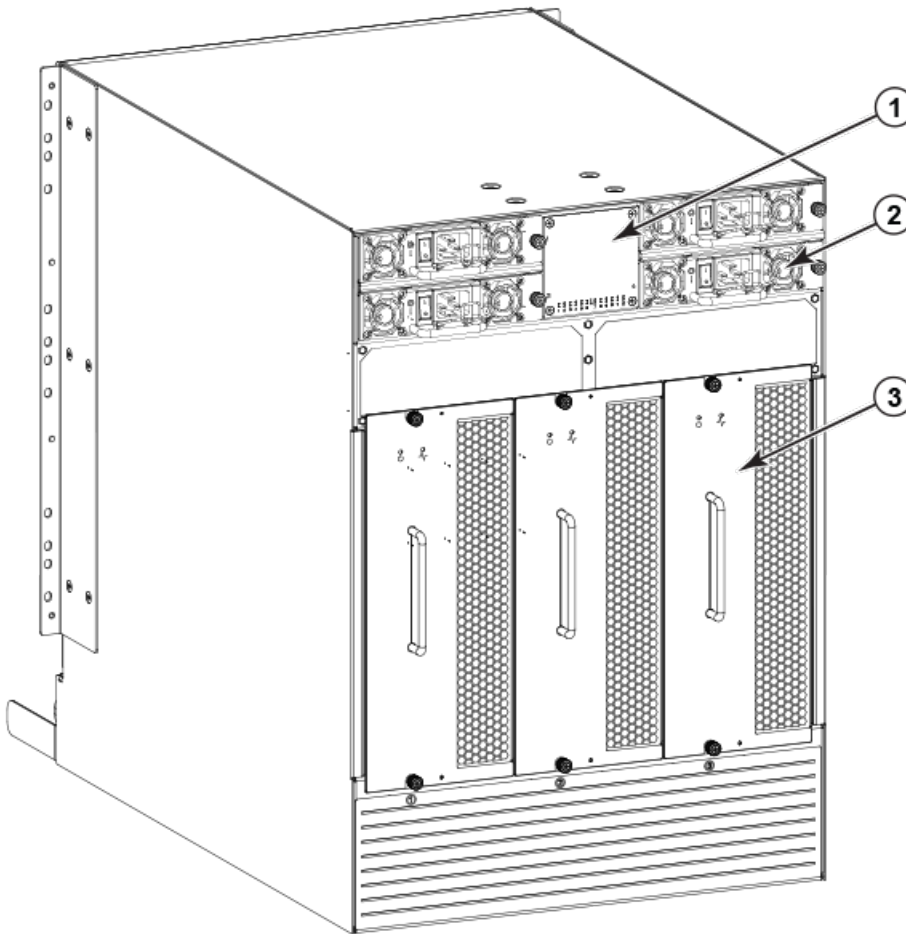

1. WWN bezel (logo plate - WWN card behind)
2. Power supply
3. Blower assembly

Supported blades

The following table summarizes the port, application, control processor, and core switch blades that are supported in the device.

Table 1: Blades available for the device

Description	Name	Function
Control processor blade	CP8	The CP8 blade contains the control plane for the chassis. There are two CP8 blades for redundancy. This control processor blade is compatible with the Brocade DCX 8510-8, Brocade DCX 8510-4, Brocade DCX-4S, and Brocade DCX platforms.
Core switch blade	CR16-8	The CR16-8 blade contains the ASICs for switching between port blades. Every port blade connects to each core switch blade. There can be up to 512 16-Gbps or 8-Gbps total ports for port blades. Each core switch blade connects to 128 backplane ports. Core switch blades have additional front port connectivity to connect multiple chassis and backplane connections for the storage server blade. This core switch blade is compatible only with the Brocade DCX 8510-8. Requires specific type of QSFP transceivers.
32-port 8-Gbps port blade	FC8-32E	A 32-port Brocade port blade supporting 2, 4, and 8 Gbps Fibre Channel port speeds. This port blade is compatible with the Brocade DCX 8510-8 and Brocade DCX 8510-4. This blade requires Fabric OS v7.0.1 or later to run in this chassis.
48-port 8-Gbps port blade	FC8-48E	A 48-port Brocade port blade supporting 2, 4, and 8 Gbps Fibre Channel port speeds. This port blade is compatible with the Brocade DCX 8510-8 and Brocade DCX 8510-4. This blade requires Fabric OS v7.0.1 or later to run in this chassis.
64-port 8-Gbps port blade	FC8-64	A 64-port Brocade port blade supporting 2, 4, and 8 Gbps port speeds with mSFPs. This port blade is compatible with the Brocade DCX 8510-8, Brocade DCX 8510-4, Brocade DCX-4S, and Brocade DCX platforms.
32-port 16-Gbps port blade	FC16-32	A 32-port Brocade port blade supporting 2, 4, 8, 10, and 16 Gbps Fibre Channel port speeds. The blade also supports port-based in-flight encryption/decryption and compression/decompression. This port blade is compatible with the Brocade DCX 8510-8 and Brocade DCX 8510-4 and requires Fabric OS v7.0.0 or later to run in this chassis.
48-port 16-Gbps port blade	FC16-48	A 48-port Brocade port blade supporting 2, 4, 8, 10, and 16 Gbps Fibre Channel port speeds. The blade also supports port-based in-flight encryption/decryption and compression/decompression. This port blade is compatible with the Brocade DCX 8510-8 and Brocade DCX 8510-4 and requires Fabric OS v7.0.0 or later to run in this chassis.
64-port 16-Gbps port blade	FC16-64	A 64-port Brocade port blade supporting 4, 8, and 16-Gbps Fibre Channel port speeds. The blade also supports port-based in-flight encryption/decryption and compression/decompression. This port blade is compatible with the Brocade DCX 8510-8 and Brocade DCX 8510-4 and requires Fabric OS v7.3.0 or later to run in this chassis. Requires specific type of QSFP transceivers.
Fibre Channel over Ethernet blade	FCOE10-24	The FCOE10-24 blade enables FCoE functionality over existing Ethernet infrastructure utilizing CEE protocols. It has 24 10-GbE ports available. This FCoE application blade is compatible with the Brocade DCX 8510-8, Brocade DCX-4S, and Brocade DCX platforms. This FCoE blade can be used in the same chassis with only the FC8-32E and FC16-32 port blades. This FCoE blade cannot be used with any other FC port blades or application blades in the same chassis. Refer to the Fabric OS Release Notes for limitations in using this blade.
Storage encryption blade	FS8-18	The FS8-18 blade enables data cryptographic (encryption/decryption) and data-compression capabilities for data-at-rest. It has 16 Fibre Channel optical SFP ports. This application blade is compatible with the Brocade DCX 8510-8, Brocade DCX 8510-4, Brocade DCX-4S, and Brocade DCX platforms and requires Fabric OS v7.0.0 or later to run in the 8510-4 and 8510-8 chassis.

Description	Name	Function
FCIP extension blade	FX8-24	The FX8-24 blade enables FCIP functionality over existing IP infrastructure. It has 12 FC ports, 10 1-GbE ports, and two 10-GbE ports available. This application blade is compatible with the Brocade DCX 8510-8, Brocade DCX 8510-4, Brocade DCX-4S, and Brocade DCX platforms and requires Fabric OS v7.0.0 or later to run in the DCX 8510-4 and DCX 8510-8 chassis.

Chassis slots numbering

The chassis slots are numbered and used for the following purpose.

- Numbered 1 through 12, from left to right when facing the port side of the Brocade DCX 8510-8.
- Slots 6 and 7 can be used only to install the control processor blades (CP8).
- Slots 5 and 8 can be used only to install the core switch blades (CR16-8).
- Slots 1-4 and 9-12 can be filled with port, application, or encryption blades.
- Unused slots must be filled with blade filler panels to maintain adequate cooling.

Port numbering

The device uses the following port numbering method.

Table 2: Port numbering and trunking port groups

Blade	Port numbering	Trunking port groups
CR16-8 core blade	<ul style="list-style-type: none"> • 0 through 7 from bottom to top on the left set of ports. • 8 through 15 from bottom to top on the right set of ports. 	<ul style="list-style-type: none"> • Trunk group 0: QSFP ports 0-3 and 8-11. • Trunk group 1: QSFP ports 4-7 and 12-15. <p>Each connector is a group of four 16-Gbps ports. For supported QSFPs, refer to Qualified transceivers for FC16-64 port blade.</p> <p>Note: CR16-8 core blade</p> <p>Individual FC ports within the same QSFP port cannot form a trunk. A trunk has to comprise of individual FC ports from different QSFP ports.</p>
FC8-32E port blade	<ul style="list-style-type: none"> • 0 through 15 from bottom to top on the left set of ports. • 16 through 31 from bottom to top on the right set of ports. 	Trunk groups: 0-7, 8-15, 16-23, and 24-31.
FC8-48E port blade	<ul style="list-style-type: none"> • 0 through 23 from bottom to top on the left set of ports • 24 through 47 from bottom to top on the right set of ports. 	Trunk groups: 0-7, 8-15, 16-23, 24-31, 32-39, and 40-47.
FC8-64 port blade	<ul style="list-style-type: none"> • 0 through 31 from bottom to top on the left set of ports. • 32 through 63 from bottom to top on the right set of ports. 	Trunk groups: 0-7, 8-15, 16-23, 24-31, 32-39, 40-47, 48-55, and 56-63. (* - Octet 56-63 E_Port trunks are permitted on the logical or base switch only.)
FC16-32 port blade	<ul style="list-style-type: none"> • 0 through 15 from bottom to top on the left set of ports. • 16 through 31 from bottom to top on the right set of ports. 	Trunk groups: 0-7, 8-15, 16-23, and 24-31.

Blade	Port numbering	Trunking port groups
FC16-48 port blade	<ul style="list-style-type: none"> 0 through 23 from bottom to top on the left set of ports. 24 through 47 from bottom to top on the right set of ports. 	Trunk groups: 0-7, 8-15, 16-23, 24-31, 32-39, and 40-47.
FC16-64 port blade	<ul style="list-style-type: none"> 0 through 63 from bottom to top. 	Trunk groups: 0-7, 8-15, 16-23, 24-31, 32-39, 40-47, 48-55, and 56-63. These are QSFP ports 0-15. For supported QSFPs, refer to Qualified transceivers for FC16-64 port blade .
FCOE10-24 blade	0 through 23 in two vertical rows from bottom left to top right.	N/A
FS8-18 blade	<ul style="list-style-type: none"> 16 FC ports: 0 through 15 from bottom to top. Two 10/100/1000 BaseT ports: GE0 and GE1 from the bottom. 	<ul style="list-style-type: none"> Trunk group 0: FC ports 0-7 Trunk group 1: FC ports 8-15
FX8-24 blade	<ul style="list-style-type: none"> FC ports labeled FC on the front panel: 0 through 11 in two vertical columns of six ports starting from the bottom left and bottom right in the lower group of 12 ports. Two 10-GbE ports labeled 10GE on the front panel: 0 and 1 in the left column just above the FC ports. 1-GbE ports labeled GE on the front panel: 0 through 9 in both columns above the FC and 10GE ports. 	<ul style="list-style-type: none"> Trunk group 0: FC ports 0-1 Trunk group 1: FC ports 6-7 Trunk group 2: FC ports 2-5 and 8-11

High availability

The following features contribute to the high availability the device:

- Redundant, hot-swappable FRUs, including blades, power supplies, blowers, and WWN cards
- Enhanced data integrity on all data paths
- Fabric Shortest Path First (FSPF) rerouting around failed links
- Integration with Simple Network Management Protocol (SNMP) managers
- Automatic control processor failover
- Nondisruptive "hot" software code loads and activation
- Easy configuration, save, and restore

The high availability software architecture provides a common framework for all applications that reside on the system, allowing global and local states to be maintained through any component failure. High availability elements consist of the High Availability Manager, the heartbeat, the fault/health framework, the replicated database, initialization, and software upgrade.

The High Availability Manager controls access to the standby control processor, facilitates software upgrades, prevents extraneous CP failover activity, closes and flushes streams, provides flow control and message buffering, and supports a centralized active and standby state.

Reliability

The device uses the following error detection and correction mechanisms to ensure reliability of data:

- Error Detection and Correction over main control processor memory.
- Error Detection and Correction mechanism, which checks for encoder errors and fault isolation (EDFI), such as cyclic redundancy checking (CRC), parity checking, checksum, and illegal address checking.
- Power-on self-test (POST).
- Dual control processors that enable hot, nondisruptive fast firmware upgrades.
- One serial port and two Ethernet ports (on each control processor) for management and for service. Offline control processor diagnostics and remote diagnostics simplify troubleshooting. The standby control processor monitors diagnostics to ensure the system is operational should a failover be necessary.
- Bus monitoring and control of blades and other field-replaceable units (FRUs).

Serviceability

The device provides the following features to enhance and ensure serviceability:

- Modular design with hot-swappable components.
- Flash memory that stores two firmware images per control processor.
- USB port on control processor blades for most tasks that formerly required an FTP/SCP server, including software and firmware upgrades.
- Nonvolatile random-access memory (NVRAM), containing the OEM serial number, Brocade serial number, revision information, and part number information.
- Background health-check daemon.
- Memory scrubber, self test, and bus ping to determine if a bus is not functioning.
- RASlog messages.
- SMI-S compliant.
- Hardware and software watchdog timers.
- Status LEDs.
- Predictive diagnostics analysis through Fabric Watch.
- SNMP (including version 3) integration with higher-layer managers.

Software features

The Fabric OS allows any Fibre Channel-compliant device to attach to the switches as long as it conforms to the device login, name service, and related Fibre Channel standards. Each operating environment requires that a Fibre Channel host bus adapter (HBA) be available with a standards-compliant driver for correct interface to the fabric.

Fabric OS consists of a set of embedded applications running on top of an embedded Linux operating system kernel. Some of these applications include:

- Name server
- Alias server
- Zone server
- Simple Network Management Protocol (SNMP) agent
- SMI-S compliant API
- Syslog auditing
- Reliable Commit Service (RCS)
- NTP
- Tasks to manage address assignment, routing, link initialization, fabric initialization, link shutdown, the device shutdown, and the user interface

Security

The following list highlights some of the key security features available in the device and in other Brocade enterprise-class products running Fabric OS 7.0.1 or later. For details, contact your device supplier and refer to the Brocade White Paper, "The Growing Need for Security in Storage Area Networks."

- DH-CHAP
- SSHv2 (using AES, 3DES, RSA)
- HTTPS (using AES)
- SNMPv3
- FC-SP
- Secure RPC
- Secure file copy (SCP)
- Telnet disable
- Telnet timeout
- IP filters (block listeners)
- Secure passwords (centralized control through RADIUS/CHAP)
- Multiple user accounts (MUAs) (Up to 255)
- Role-based access controls (RBACs)
- Administrative domains/Virtual fabrics
- Boot PROM password reset
- Password hardening policies
- Up front login in Web Tools
- Login banner
- Monitoring of attempted security breaches (through audit logging)
- Monitoring of attempted security breaches (through Fabric Watch Security Class)
- Fibre Channel security policies: DCC and SCC
- Trusted Switch (FCS) for central security management
- Management access controls (SNMPv3, Telnet, FTP, serial port, front panel)
- Hardware-enforced zoning by WWN, domain/port ID, or both
- Default zoning
- RSCN suppression and aggregation
- Configurable RSCN suppression by port
- NTPv3 (to synchronize timestamps)
- Event auditing
- Change tracking
- Firmware change alerts in Fabric Manager
- Persistent port disable
- Persistent domain ID
- E_Port disable

Network manageability

The device has a single domain and is managed as a single element with Brocade Network Advisor. The device responds to its own IP address and appears as a separate entity to the Telnet protocol and SNMP.

All management interfaces, such as Telnet, Web Tools, standards-compliant SMI-S, and Management Server, support a "port N within blade M" naming scheme.

The device supports SNMPv1 and SNMPv3. When SNMP devices send SNMP messages to a management console running SAN management software, the information is stored in a management information base (MIB). Fabric OS v7.0.0 and later supports the latest Fibre Alliance Fibre Channel Management (FCMGMT) and Storage Management Initiative (SMI) MIBs, which allow common information necessary for management software to provide information to a SAN administrator. Refer to the *Fabric OS MIB Reference* for additional MIB information.

Preparing for the Installation

Installation and safety considerations

Read the following sections before preparing to install the device.

DANGER

Use only optical transceivers that are qualified by Broadcom and comply with the FDA Class 1 radiation performance requirements defined in 21 CFR Subchapter I, and with IEC 60825 and EN60825. Optical products that do not comply with these standards might emit light that is hazardous to the eyes.

- [Caution and Danger Notices](#).
- [Managing cables](#) and plan for cable management.
- Refer to the *Brocade DCX 8510 Backbone Technical Specification*, power supply specifications section, and plan for meeting the power supply standards based on your device configuration.

Follow these steps to ensure correct installation and operation.

1. Ensure that dedicated electrical branch circuits with the following characteristics are available:
 - 200 - 240 VAC, 50-60 Hz, two branch circuits are recommended for high availability and maximum blade usage when configured with 192 or more 16-Gbps ports.
 - 200 - 240 VAC, 50-60 Hz, four branch circuits are recommended for high availability and maximum blade usage when configured with 384 or more 16-Gbps ports.
 - 110 - 120 VAC, 50-60 Hz, four branch circuits are highly recommended.
 - Two or four cables for 200 - 240 VAC service; up to four cables for 110 - 120 VAC service
 - Protected by a circuit breaker in accordance with local electrical codes
 - Supply circuit, line fusing, and wire size adequate to the electrical rating on the chassis nameplate
 - Location close to the chassis and easily accessible
 - Grounded outlets installed by a licensed electrician and compatible with the power cords



CAUTION

Use a separate branch circuit for each power cord, which provides redundancy in case one of the circuits fails.

2. Plan for cable management before installing the chassis.

Cables can be managed in a variety of ways, such as by routing cables below the chassis, to either side of the chassis, through cable channels on the sides of the cabinet, or by using patch panels.

3. Ensure that the following is available for configuration of the device:
 - Workstation with an installed terminal emulator, such as HyperTerminal
 - Serial cable (provided)
 - Three Ethernet cables (including one spare)
 - Access to an FTP server for backing up the switch configuration or collecting `supportsave` output data (optional)
 - A Brocade USB stick for collecting `supportsave` output data (optional)
 - Transceivers (copper and optical) and compatible cables

4. Ensure that the air intake and exhaust vents on the device will have a minimum of 5.1 cm (2 in.) of airspace when the device is installed.
5. Ensure that the air temperature on the air intake side of the device will be less than 40°C (104°F) during operation when the device is installed.

Time and items required

The following table describes the main installation and setup tasks, the estimated time required for each, and the items required to complete the task for a device that is fully populated with FC16-64 port blades. Configurations with fewer blades or ports require less time. These time estimates assume a prepared installation site and appropriate power and network connectivity.

Table 3: Installation tasks, time, and items required

Installation task	Time estimate	Items required
Site preparation and unpacking the device	30 minutes	1/2-in. socket wrench (to remove pallet bolts). #2 Phillips screwdriver (for cable management comb). Pallet jack. Hydraulic lift or assisted lift, able to raise to a minimum of 140 cm (55 in.), with a minimum capacity of 115 kg (254 lb). To know the weight of your device fully populated with the required port blades, refer to the <i>Brocade DCX 8510 Backbone Technical Specification</i> .
Installing rack mount kit or Airflow Diversion and Port-Side Exhaust Kit	30 minutes	Refer to applicable rack mount kit procedures located in this guide.
Mounting and securing the device in rack	30 minutes	
Installing power cables and powering on the device	20 minutes	Power cables (provided in the device accessories kit).
Establishing serial connection, logging in to the device, and configuring IP addresses	20 minutes	Serial cable (provided in the accessory kit). Workstation computer with a serial port or terminal server port and a terminal emulator application (such as HyperTerminal). Ethernet IP addresses for the device and for both control processor blades: total three addresses.
Installing an Ethernet cable, opening a Telnet session, and configuring the device domain ID, date and time, and additional system parameters. Verify and back up configuration.	20 minutes	Ethernet cabling (optional) for Telnet access. Refer to the <i>Brocade Fabric OS Administration Guide</i> .
Installing transceivers as needed	20-30 minutes or longer if you are using high-density port blades.	SFP+, mSFP, and QSFP optical transceivers as needed.
Attaching fiber-optic cables, cable ties, and cable guides	2-3 hours	Fiber-optic cables, cable ties, and cable management comb.

Items included with the device

The device ships with the following:

- The chassis, populated with:
 - Control processor blades (CP8)
 - Core switch blades (CR16-8)
 - Port blades, application blades, and encryption blades (included based on customer specification)
 - Blade slot filler panels (for slots not filled by blades)
 - WWN cards
 - WWN bezel (logo plate)
 - Power supplies
 - Power supply filler panel (included if there are fewer than four power supplies)
 - Blower assemblies
 - Cable management comb
 - Chassis door
- Accessory kit containing the following items:
 - A QuickStart Guide
 - ESD grounding strap
 - USB device
 - RS-232 serial cable. The RS-232 cable has an adapter at one end that can be removed to provide an RJ-45 style connector.
- 14U Rack Mount Kit with instructions (includes rear brackets and bottom support rails)

Order the Brocade-branded optical transceivers (SFP+, mSFP, and QSFP). The device supports SWL, LWL, and ELWL transceivers. The mSFPs and QSFPs are SWL transceivers only.

NOTE

For information about the SFP+, mSFP, and QSFP transceivers that are qualified for the device, refer to [Transceiver removal and replacement](#).

Mounting the Device

Mounting options

This device can be installed as a standalone unit on a flat surface or mounted a 19-inch Electronic Industries Association (EIA) or two-post telecommunications (TELCO) equipment rack.

The following rack mount kits can be used for the Brocade DCX 8510-8. Refer to the appropriate instructions in this guide for installation.

- 14U Chassis Rack Mount Kit (27-31 inch) for Four-Post Racks - XBR-DCX-0120.
- 14U Chassis Rack Mount Kit (22-inch fixed-shelf brackets that adjust to 27 inches) for Four-Post Racks - XBR-DCX-0152.
- 14U Chassis Mid-Mount Rack Kit for Two-Post Racks - XBR-DCX-0121.

NOTE

These rack mount kits are supported at the date of this Hardware Installation Guide. For the latest support information, contact your Brocade representative.

Mounting precautions

Ensure that the following amount of space is available in the rack.

NOTE

1U is equal to 4.45 cm (1.75 inches).

- 14 rack units (14U) high.
- 61.29 cm (24.09 inch) deep.
- 43.74 cm (17.22 inch) wide.

The following general precautions for mounting the device.

- Review [Installation and safety considerations](#) before mounting the device and ensure that all facility requirements are met.
- Plan to install the device with the nonport side facing the air-intake aisle. The device can be installed facing either direction, if serviceability and cooling requirements are met.
- Ensure that the air intake and exhaust vents have a minimum of 5.1 cm (2 in.) of airspace.
- Ensure that the air temperature on the air intake side is less than 40°C (104°F) during operation.
- Use a hydraulic lift or assisted lift that can raise a minimum of 140 cm (55 in.), with a minimum capacity of 115 kg (254 lb). Refer to the *Brocade DCX 8510 Backbone Technical Specification* for the weight of your device, fully populated with the required blades.



CAUTION

Do not use the port cover tabs to lift the module. They are not designed to support the weight of the module, which can fall and be damaged.



CAUTION

Make sure the airflow around the front and back of the device is not restricted.



DANGER

Mount the devices you install in a rack as low as possible. Place the heaviest device at the bottom and progressively place lighter devices above.

**DANGER**

Use safe lifting practices when moving the product.

**CAUTION**

To prevent damage to the chassis and components, never attempt to lift the chassis using the fan or power supply handles. These handles were not designed to support the weight of the chassis.

**CAUTION**

Never leave tools inside the chassis.

**DANGER**

Make sure the rack housing the device is adequately secured to prevent it from becoming unstable or falling over.

Unpacking, transporting, and installing the device

Use the following procedure to unpack and install your device.

**DANGER**

A fully populated chassis (eight FC16-64 port cards, 512 ports) weighs approximately 104.3 kg (230 lbs) and requires a hydraulic or assisted lift to install it.

1. Unpack the device.
 - a) Cut the bands that encircle the packaging.
 - b) Remove the lid and the kits and foam from the top of the chassis.
 - c) Lift the cardboard box off the chassis and remove the plastic bag from around the chassis. Save the packing materials for use when returning the old chassis.
 - d) Leave the chassis on top of the plastic shipping tray if the chassis must be transported to the installation location.

NOTE

The device packaging does not incorporate a wood pallet and pallet brackets. The chassis sits on top of a plastic shipping tray.

2. Use a pallet jack or other assisted lift to transport the new chassis to the installation area. Doorways must be wider than 36 in. (91 cm) to accommodate the chassis.
3. Remove the following items from the chassis and set aside.
 - *14U Rack Mount Kit*
 - Accessory kit
 - Packing foam
 - Antistatic plastic

4. Remove the chassis door from the device.
5. Remove the cable management comb.
6. If installing the device in an equipment rack, install the applicable rack mount kit using instructions in [Mounting the Device](#).
7. Use a lift to raise the chassis to the correct level. If installing the chassis in a cabinet, follow the instructions provided by the rack kit manufacturer.
8. If applicable, lock the wheels of the lift.
9. Gently slide the chassis onto the final installation surface, ensuring that it remains supported during the transfer.
10. Ensure that the chassis is oriented so that the nonport side has access to intake air (cool).
11. Reinstall the cable management comb.
12. Reinstall the door. The door must be installed to meet EMI compliance.

Installing the 14U Rack Mount Kit for Four-Post Racks (XBR-DCX-0120 and XBR-DCX-0152)

Use the following instructions to install a modular device in a 48.3 cm (19-in.) EIA rack using the 14U Rack Mount Kit for Four-Post Racks (XBR-DCX-0120 and XBR-DCX-0152).

Two rack-mount kits are available.

- XBR-DCX-0120 - Contains shelf brackets that telescope from 68.58 cm (27 in.) to 78.74 cm (31 in.) to fit the majority of racks.
- XBR-DCX-0152 - Contains 55.88 cm (22 in.) fixed shelf brackets that adjust to 68.58 cm (27 in.).

Observe the following when mounting this device:

- Use Electronic Industries Association (EIA) standard racks. Ensure that the space in the 48.3 cm (19-in.) EIA rack is 14U high.
- Verify that the additional weight of the chassis does not exceed the weight limits of the rack.
- Before mounting your device, review any specific installation and facility requirements in the Hardware Installation Guide for the device.
- Before mounting your device, review any specific installation and facility requirements in this Hardware Installation Guide.
- Hardware devices illustrated in these procedures are only for reference and may not depict the device you are installing into the rack.

Time and Items Required

Allow approximately one hour to unpack and install a device in a rack.

The following tools are required when installing the 14U Rack Mount Kit for Four-Post Rack:

- Torque screwdriver with No. 2 Phillips screwdriver tip
- Slotted (flat blade) screwdriver
- Hydraulic or assisted lift with a minimum raise of 140 cm (55 in.) and a minimum capacity of 113 kg (250 lb)

Parts List

The following table lists 14U Rack Mount Kit parts and quantities for different installations. See the figure following the table to identify these parts.

Table 4: 14U Rack Mount Kit Parts and Quantities

Description	Installation	Quantity
Left rack mount shelf bracket (rail brackets may differ from ones shown in figure)	All	1
Right rack mount shelf bracket (rail brackets may differ from ones shown in figure)	All	1
10-32 x 5/8 in. (1.58 cm) panhead Phillips screw and washer (torque to 37 cm-kg [32 in.-lb])	All	6
10-32 clip nut	For rack rails with round holes	6
1/4-20 x 1/2 in. (1.27 cm) panhead Phillips screw with lock washer (torque to 92 cm-kg [80 in.-lb])	For rack rails with round holes	16
10-32 retainer nut	For rack rails with square holes	6
1/4-20 x 1/2 in. (1.27 cm) panhead Phillips screw with thread locker (torque to 92 cm-kg [80 in.-lb])	For rack rails with square holes	16
3/8 in. (0.953 cm) alignment washer	For rack rails with square holes	16

NOTE

Depending on the device and installation, not all the parts may be used on the device type.

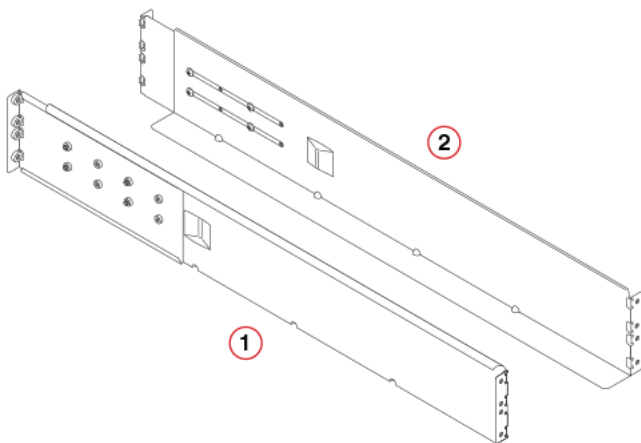
Figure 3: 14U Rack Kit Parts

1. Left Rack Mount Shelf Bracket
2. Right Rack Mount Shelf Bracket
3. 10-32 x 5/8 in. (1.58 cm) Panhead Phillips Screw and Washer

4. 10-32 Clip Nut (for cabinets that have rails with round holes)
5. 1/4-20 x 1/2 in. (1.27 cm) Panhead Phillips Screw with Lock Washer (for cabinets that have rails with round holes)
6. 10-32 Retainer Nut (for cabinets that have rails with square holes)
7. 1/4-20 x 1/2 in. (1.27 cm) panhead Phillips screw with thread locker (for cabinets that have rails with square holes)
8. cm 3/8 in. (0.953 cm) Alignment Washer (for cabinets that have rails with square holes)

Parts List – NEBS Kit

The following table lists the parts supplied in the XBR-SLX9850-8-NEBS-KIT to help direct airflow away from the rack area. This kit is only supported for specific devices, and may not apply to the device that you are installing.

NOTE

Depending on the device and installation, not all of the parts may be used.

Verify that the items listed in the following figure are included in the NEBS kit.

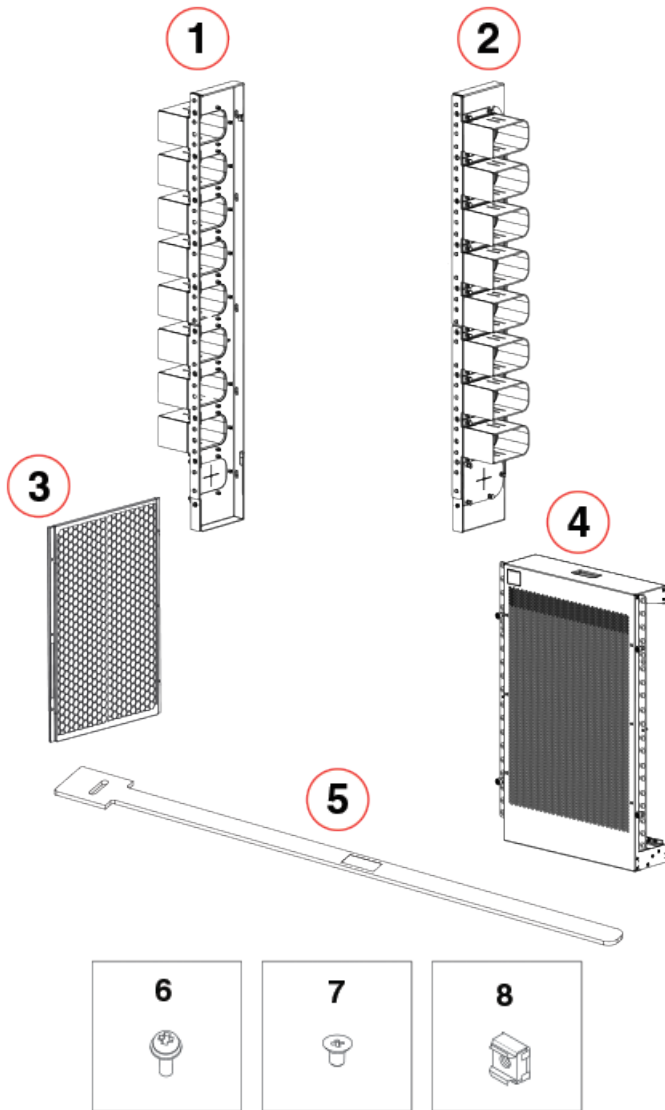
Figure 4: NEBS Kit Parts List

1. Left Cable Comb Assembly (1)
2. Right Cable Comb Assembly (1)
3. Air Filter (1)
4. Chassis Door (1)
5. Velcro Strap (8)
6. Screw, 10-32 x .63-in., Square Cone Washer (10)
7. Screw, 8-32 x .312 in., Flathead (20)
8. Nut Retainer (6)

Assembling the rack hardware

Attach the left and right rack mount shelf brackets to the rack rails.

NOTE

If cables are to be routed down through the cable management comb, allow space below the brackets for cable management

1. Locate the shelf brackets in the device.
2. Locate and loosen the screws on the adjustable ends of the brackets (see the following figure) to allow for adjustment to rack depth.

Figure 5: Left and right shelf brackets installed on rails

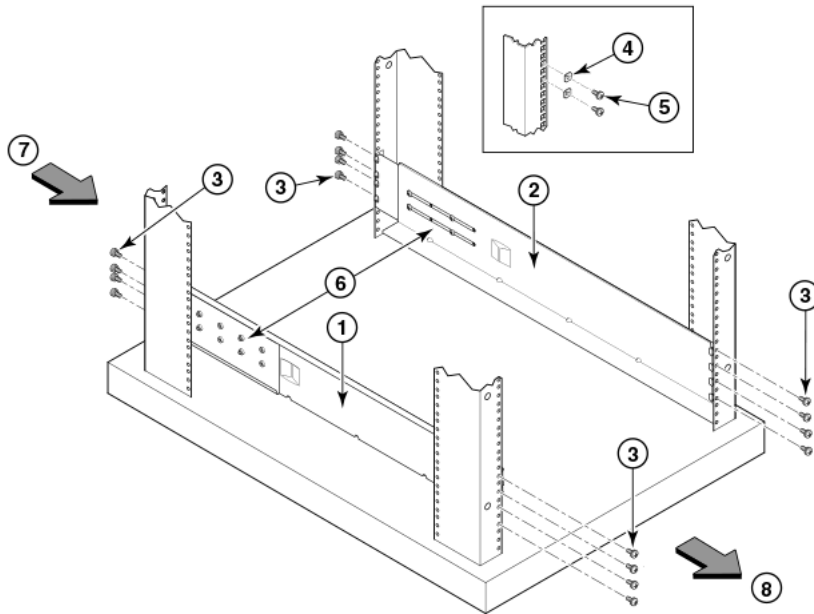

1. Left rack mount shelf bracket
2. Right rack mount shelf bracket
3. 1/4-20 x 1/2 in. (1.27 cm) panhead Phillips screw with lock washer for rails with round holes (4 on each end of each bracket, 16 total)
4. 3/8 in. (0.953 cm) alignment washer for rails with square holes (4 on each end of each bracket, 16 total)
5. 1/4-20 x 1/2 in. (1.27 cm) panhead Phillips screw with thread locker for rails with square holes (4 on each end of each bracket, 16 total)
6. Adjustable ends of shelf brackets
7. Intake air direction
8. Exhaust air direction

**CAUTION**

Use the screws specified in the procedure. Using longer screws can damage the device.

3. Position the shelf brackets with the adjustable ends on the intake air aisle side of the rack (see the previous figure).
 - For rails with round holes:
 - Position the left and right rack mount shelf brackets and attach them to the rack rails. Use eight screws with lock washers per bracket (four on each end). Tighten the screws to a torque of 80 in-lb (92 cm-kg).
 - For rails with square holes:
 - Position the left and right rack mount shelf brackets and attach them to the rack rails. Use eight screws and alignment washers per bracket (four on each end). Tighten the screws to a torque of 80 in-lb (92 cm-kg).

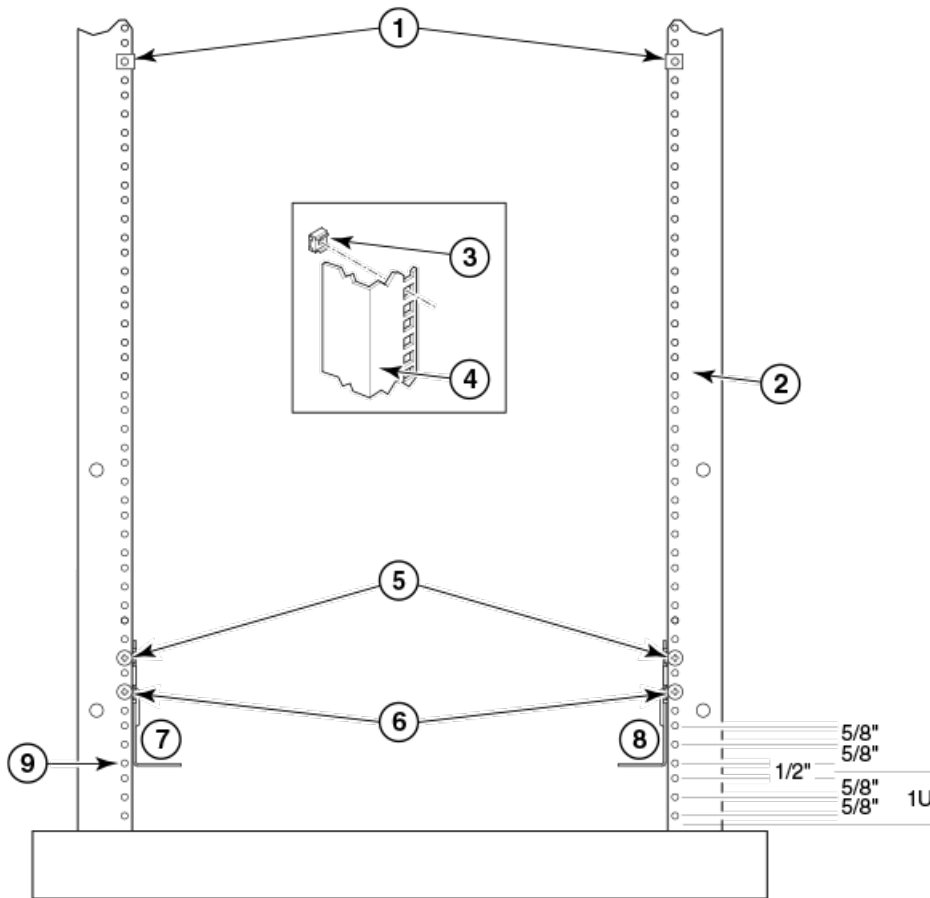
Figure 6: Nut and screw locations for mounting the device

1. 10-32 clip nuts (for round holes)
2. Rail
3. 10-32 retainer nut (for square holes)
4. Rail
5. Top screws in shelf bracket
6. Bottom screws in shelf bracket
7. Left rack mount shelf bracket
8. Right rack mount shelf bracket
9. Hole 1

NOTE

Standard EIA rails have holes in sets of three; spaces between the holes are 5/8 in., 5/8 in., and 1/2 in. (1.58 cm, 1.58 cm, and 1.27 cm).

4. Tighten the adjusting screws on the sliding portion of the rack mount shelf brackets to a torque of 32 in-lb (37 cm-kg).
5. Attach the clip nuts (for rails with round holes) or retainer nuts (for rails with square holes) to the vertical rails on the exhaust aisle side of the rack (see the previous figure). These clip nuts are used for securing the port side of the

device to the rack rails using 10-32 x 5/8 inch screws. Use three clips on each rail. Place the clips in optimum locations for securing the device to the rails.

NOTE

Do not align the clip or retainer nuts with the top or bottom holes of the mounting bracket because the screw heads will interfere with the door.

Installing the device in the rack

Use the following procedure to install the device in the rack.

**DANGER**

Use safe lifting practices when moving the product.

1. Ensure that the door, if installed, is removed from the port side of the device. For instructions, refer to instructions for removing and replacing the device door in the device installation guide.
2. Use a lift to raise the device to the level of the shelf brackets.
3. Move the lift as close as possible to the rack, with the air-intake side of the device facing the front of the rack (see the following figure).
4. If applicable, lock the wheels of the lift.
5. Gently slide the device onto the shelf brackets, ensuring that it remains supported during the transfer.

Figure 7: Positioning the device for installation in a rack

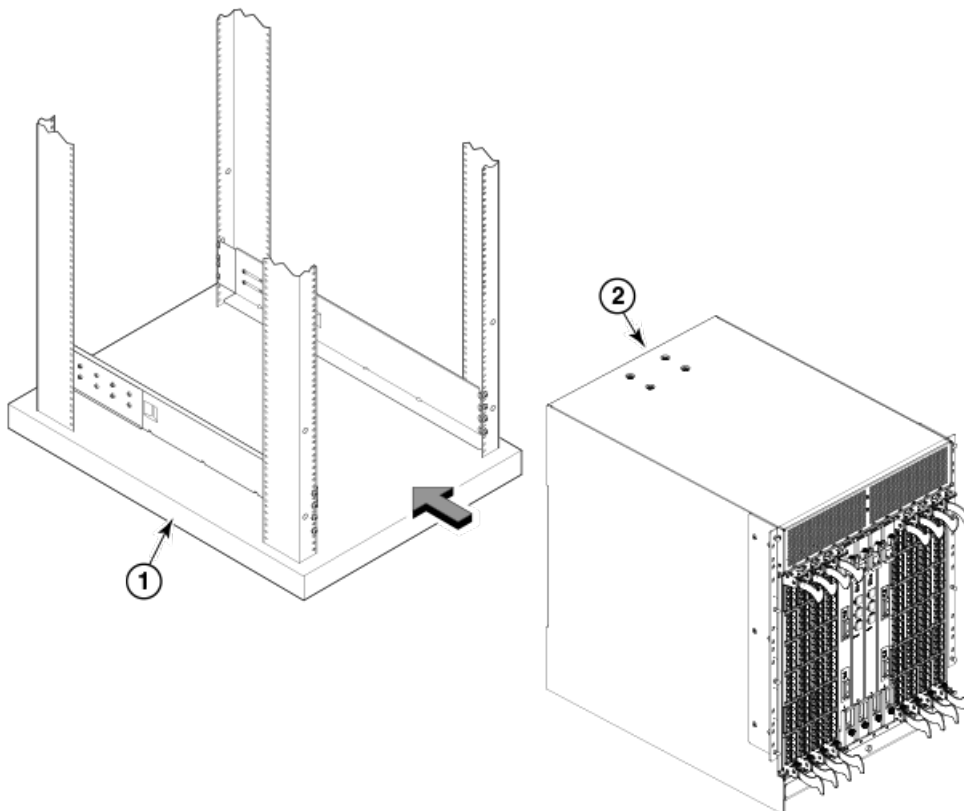

1. Rack
2. Nonport side of device

- Fasten the port side of the device to the rack rails. Use three 10-32 x 5/8 inch (1.58 cm) screws per rail. Tighten the screws to a torque of 32 in-lb (37 cm-kg). Refer to [Figure 5](#).

NOTE

Do not use the top or bottom holes of the mounting bracket because the screw heads will interfere with the door.

Figure 8: Attaching port side of device to rack rails

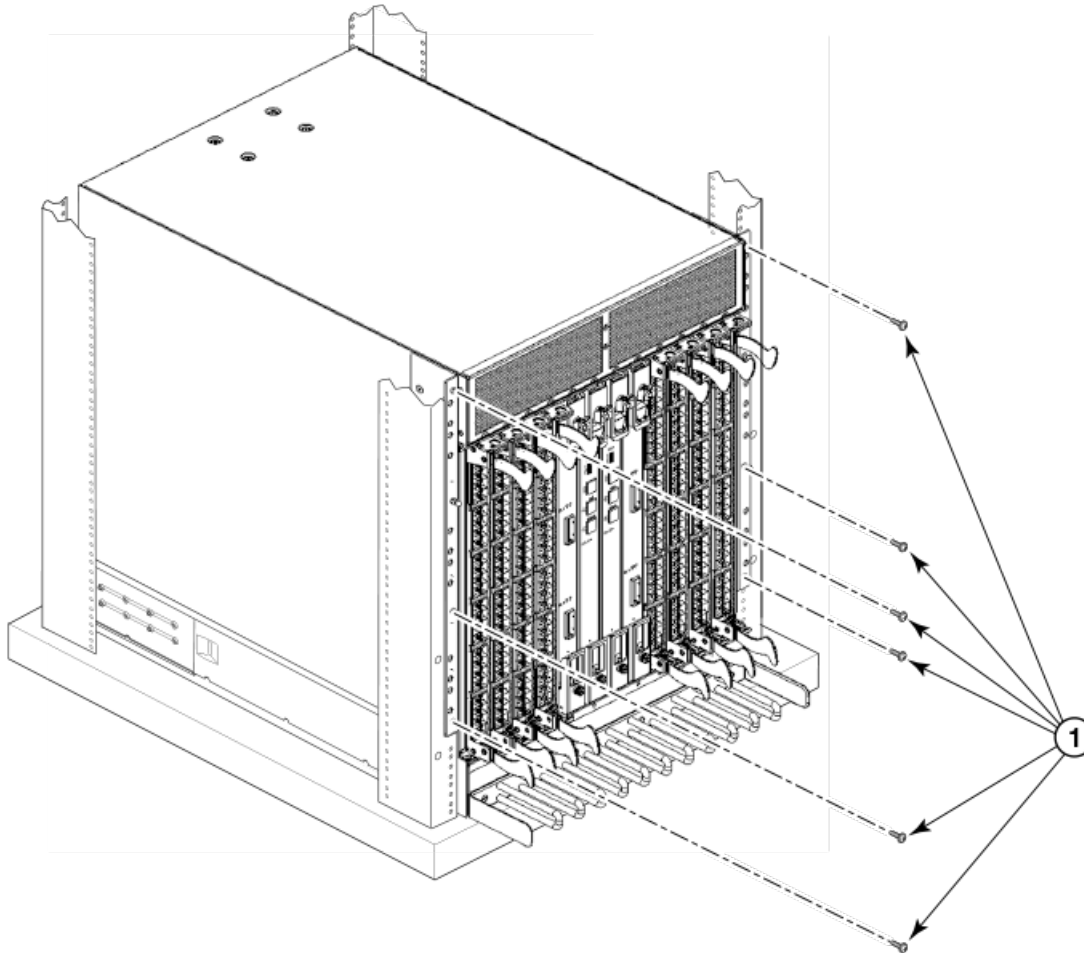

- 10-32 x 5/8 in. (1.58 cm) panhead Phillips screw with washer
- Reinstall the device door if removed from your device. For instructions, refer to the door removal and replacement procedures in your device installation guide.

Installing the 14U Chassis Mid-Mount Rack Kit for Two-Post Racks (XBR-DCX-0121)

Use the following instructions to install a Brocade modular device in a telecommunications (Telco) rack, using the 14U Chassis Mid-Mount Rack Kit for Two-Post Racks (XBR-DCX-0121).

Observe the following when mounting this device:

- The kit is compatible with rack rails that are either 7.6 cm (3 in.) or 12.7 cm (5 in.) wide (adapters are provided for 7.6 cm (3-in.) rails).
- Before mounting your device, review any specific installation and facility requirements in the Hardware Installation Guide for the device.
- Before mounting your device, review any specific installation and facility requirements in this Hardware Installation Guide.
- Hardware devices illustrated in these procedures are only for reference and may not depict the device you are installing into the rack.

Time and Items Required

Allow approximately one hour to unpack and install a chassis in a rack.

The following tools are required when installing the 14U Chassis Mid-Mount Rack Kit for Two-Post Racks.

- Torque wrench with No. 2 Phillips screwdriver tip
- Flathead screwdriver
- Hydraulic or assisted lift with a minimum raise of 140 cm (55 in.) and a minimum capacity of 113 kg (250 lbs).

Parts List

The following parts are provided with the 14U Chassis Mid-Mount Rack Kit for Two-Post Racks (XBR-DCX-0121).

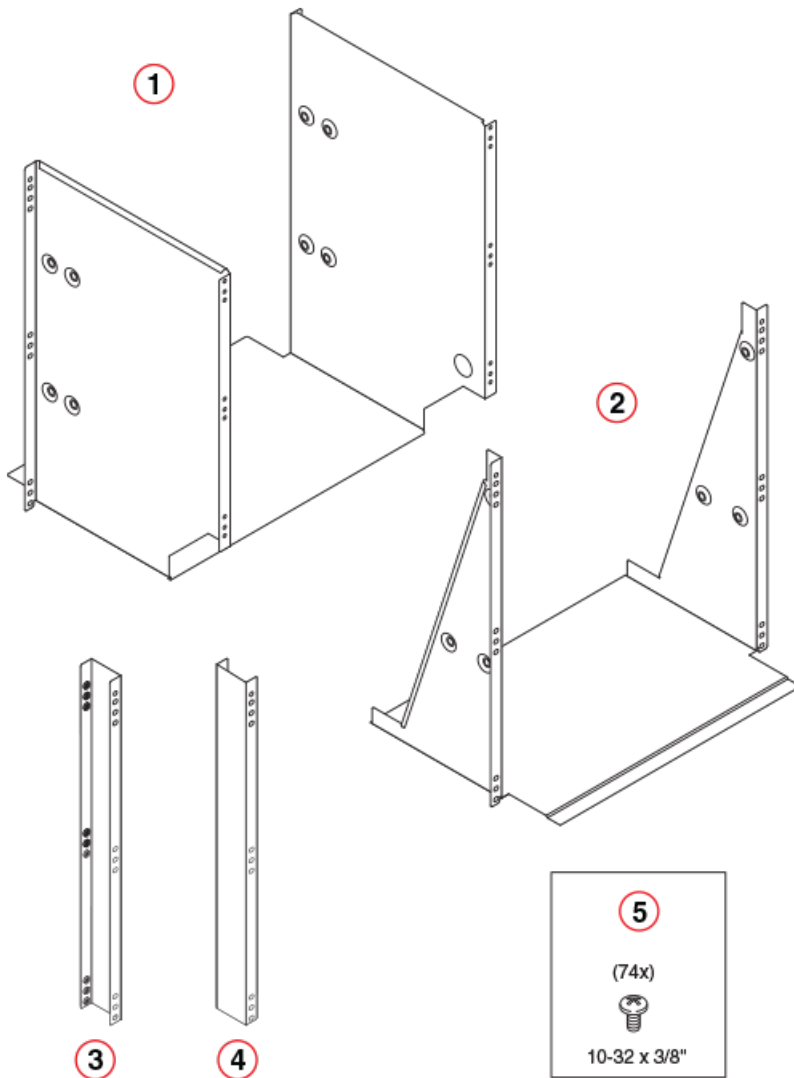
Figure 9: Rack Kit Parts

1. Tray, Front, Mid-Mount, Chassis
2. Tray, Rear, Mid-Mount, Chassis
3. Adapter, Rear, Mid-Mount, Right
4. Adapter, Rear, Mid-Mount, Left
5. Screw, 10-32 x 3/8-in. Panhead Phillips, ST, Zinc (requires a torque of 37 cm-kG (32 in.-lbs))

NOTE

Not all parts may be used with certain installations depending on the device type.

Assembling the Rack Hardware

Perform the following steps to assemble the rack hardware.

1. Attach the rear tray (with or without adapter, as required) to both rack rails. Orient the tray (see the following figure) and use nine screws (Item E) for each rail.
2. Attach the front tray to both rack rails. Orient the tray ([Figure 3](#)) and use nine screws (Item E) for each rail.
3. Verify that the rear edge of the front tray is seated into the front edge of the rear tray.

Figure 10: Attaching the Rear Tray to the Rack Rails

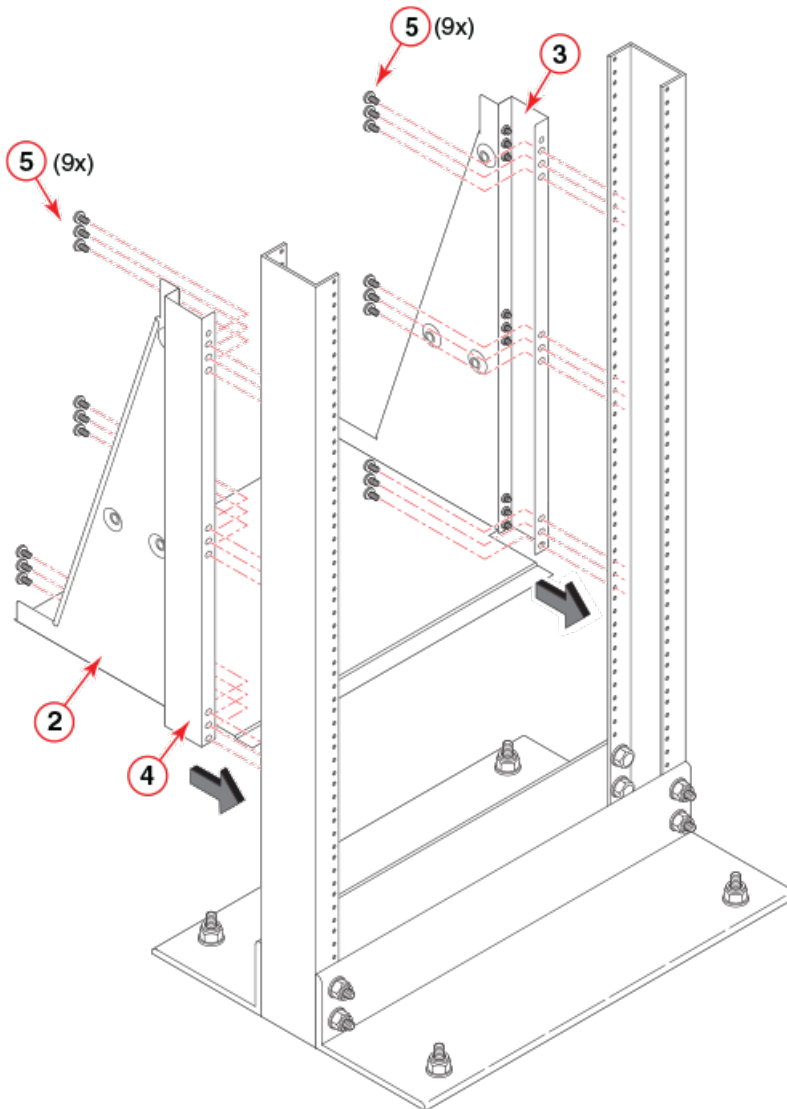

2. Tray, Rear, Mid-Mount, Chassis
3. Adapter, Rear, Mid-Mount, Right
4. Adapter, Rear, Mid-Mount, Left
5. Screws

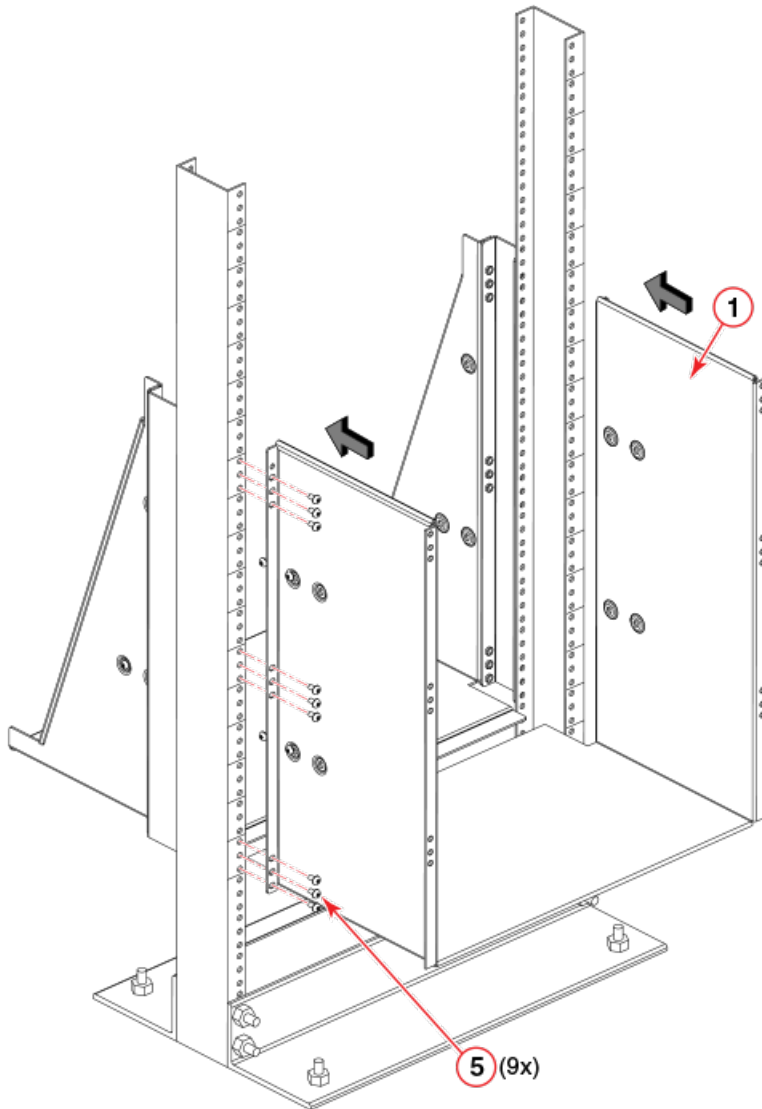
Figure 11: Attaching the Front Tray to the Rack Rails

1. Tray, Front, Mid-Mount, Chassis

5. Screws

Installing the device in the rack



DANGER

Use safe lifting practices when moving the product.

NOTE

A fully populated device requires a hydraulic or assisted lift to install into a rack.

Perform the following steps to load the device into the mid-mount trays.

1. Ensure that the door is removed from the port side of the device. For instructions, refer to the door removal and replacement procedures in your device installation guide.
2. Orient the device (refer the following figure) and use a hydraulic lift to raise it to the level of the trays.
3. If applicable, lock the wheels of the lift.
4. Slide the device into the trays until the front edge of the device is seated against the front tray.

Figure 12: Placing the device in the trays

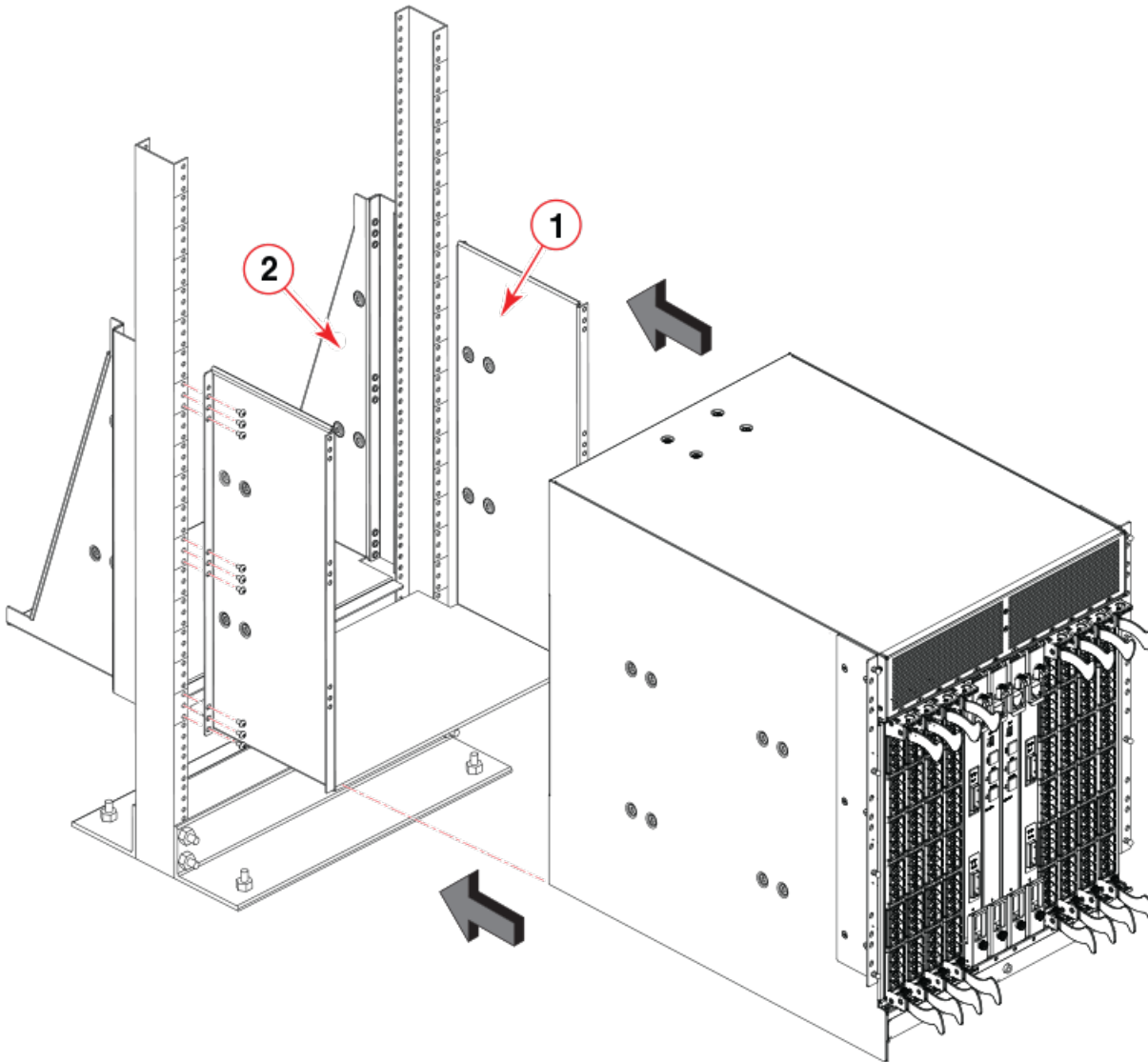

1. Tray, front, mid-mount, chassis
2. Tray, rear, mid-mount, chassis

5. Use three screws (Item 5) to attach each side of the rear tray to the device (refer the following figure).

NOTE

The screw holes in the device walls have pem nuts on the inside surface.

6. Use four screws (Item 5) to attach each side of the front tray to the device
7. Use six screws (Item 5) to attach the lip on each side of the front tray to the lip on the front of the device.

NOTE

Do not use the top or bottom holes of the Brocade mounting bracket because the door will interfere with the screw heads.

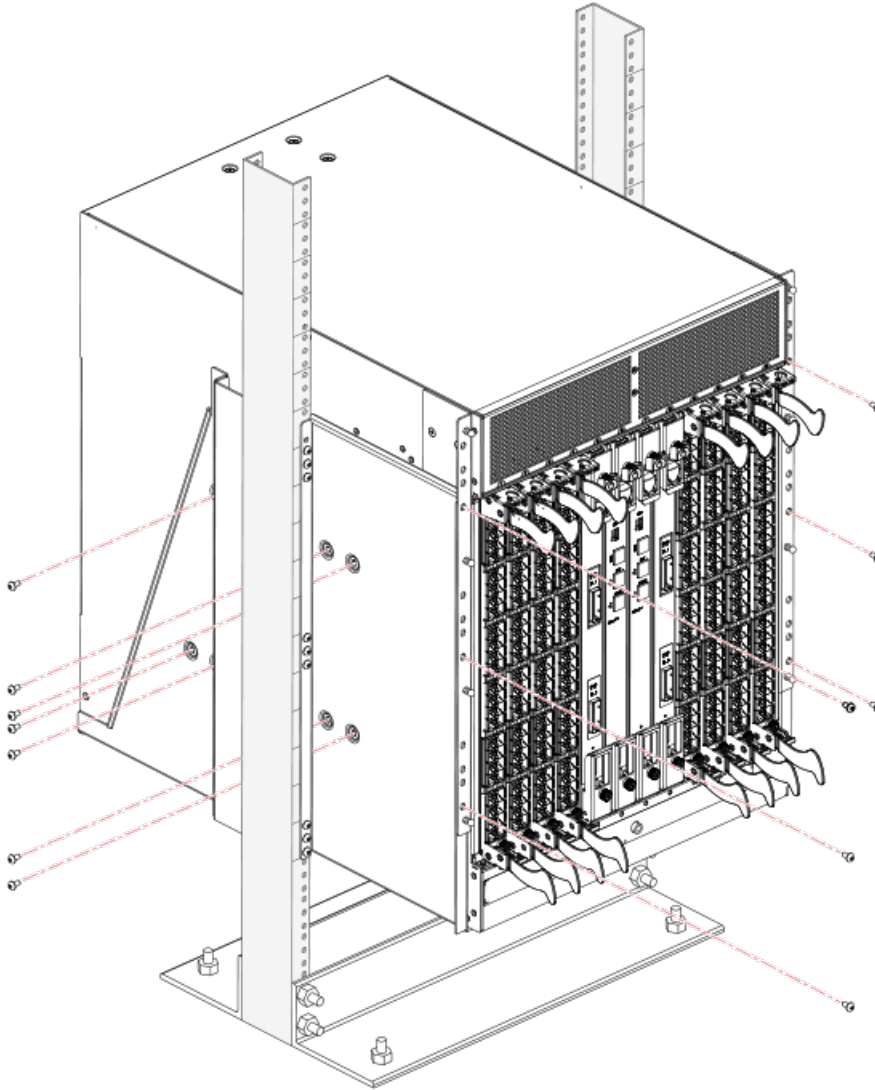
Figure 13: Attaching trays to the device

8. Reinstall the device door. For instructions, refer to the door removal and installation instructions in your device installation guide.

Cable Management

Requirements and precautions

The cable management comb ([Port side view of the device \(DCX8510-8\)](#)) is attached to the chassis under the chassis door and allows for simple cable management. The comb can be installed without service disruption.

NOTE

The minimum radius to which a 50 micron cable can be bent under full tensile load is 5.1 cm (2 in.). For a cable under no tensile load, that minimum is 3.0 cm (1.2 in.).



CAUTION

Before plugging a cable into any port, be sure to discharge the voltage stored on the cable by touching the electrical contacts to ground surface.

Cables can be organized and managed in a variety of ways, for example, using cable channels on the sides of the cabinet or patch panels to minimize cable management. Following is a list of recommendations:

NOTE

You should not use tie wraps with optical cables because they are easily overtightened and can damage the optic fibers.

- Plan for rack space required for cable management before installing the switch.
- Leave at least 1 m (3.28 ft) of slack for each port cable. This provides room to remove and replace the switch, allows for inadvertent movement of the rack, and helps prevent the cables from being bent to less than the minimum bend radius.
- If you are using Brocade ISL Trunking, consider grouping cables by trunking groups. The cables used in trunking groups must meet specific requirements, as described in the *Fabric OS Administrator's Guide*.
- For easier maintenance, label the fiber-optic cables and record the devices to which they are connected.
- Keep LEDs visible by routing port cables and other cables away from the LEDs.
- Use Velcro[®] type straps to secure and organize fiber-optic cables.

NOTE

Do not route the cables in front of the air exhaust vent, which is located at the top of the port side of the chassis.

Cable types supported on the FC16-64 port blade

The FC16-64 port blade supports simplified cable management using QSFP cables. Each QSFP cable has four links internally that run at 16-Gbps speed and the cables come in specific predetermined fixed lengths.

The FC16-64 port blade supports the following types of cables:

- QSFP to QSFP standard cables
- QSFP-SFP/LC Break-out/Split-out cables

Figure 14: QSFP to QSFP standard cables

1. QSFP MTP connector

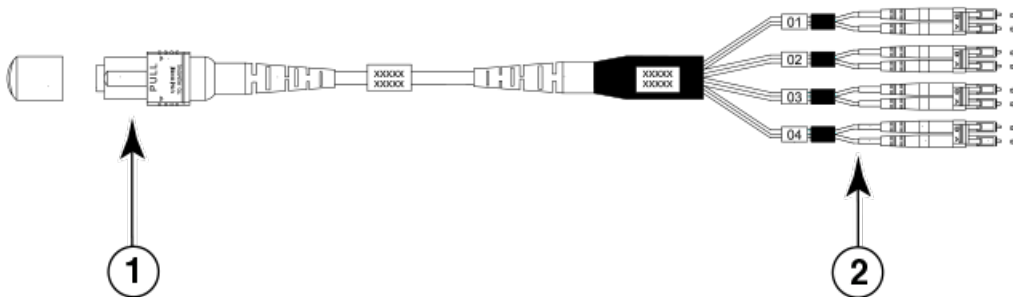
Figure 15: QSFP-SFP/LC Break-out/Split-out cables

1. QSFP MTP connector
2. SFP+ LC connectors

With the support for breakout cables, each port can be in a different mode. Inside the single physical QSFP port, individual ports can be configured as an E_Port, F_Port or EX_Port. Also, each internal port inside a single physical QSFP can be part of different Logical Switches.

With the support for breakout cables, trunking can be enabled on ports in a QSFP port group, with ports connected through breakout cables at the other end.

Installing inter-chassis links (ICLs)

Follow these guidelines when installing ICLs using fiber optic cables and transceivers. Refer to the *Brocade Fabric OS Administration Guide* for the configuration procedure and requirements. Refer to "Removing and replacing a QSFP and cable" in this hardware installation guide to install cables and transceivers.

- The QSFP ports on the core switch blades can be used only with an inter-chassis link (ICL) license. After the addition or removal of a license, the license enforcement is performed on the ports only when the `portdisable` and `portenable` commands are issued on the ports. An ICL license must be installed on all Brocade Backbones forming the ICL connection. Up to nine neighboring Brocade DCX 8510 series chassis can be connected with the MTP cables.
- An off-the-shelf MTP cable up to 100 meters can be used as an ICL cable when using the standard SWL optics. The Brocade 2 km QSFP with LWL optics has an integrated 3 meter single-mode pigtail with a male MTP connector for connectivity to a patch panel or female terminated MTP patch cable to achieve up to 2 km distances. Refer to [Using Brocade 2 km LWL QSFPs](#) for more information.
- Brocade supports fully populating a switch with ICL connections using a mixture of 50 and 100 meter SWL optics and 2 km LWL optics.
- Following are examples of maximum ICL port connections in a DCX 8510 when using 2 km LWL QSFPs. Note that limits are based on the number of buffers. If using ICLs for shorter distances, more ICL ports can be connected. There are no limitations on number of ICL ports if all ICL distances are a few hundred meters.
 - Up to 10 ICL ports can be used for 2 km distances when 16 buffer credits are configured per virtual channel.
 - Up to 16 ICL ports can be used for 1,375 meter distances when 11 buffer credits are configured per virtual channel.

The following table describes the connector port LED patterns and the recommended actions for those patterns.

Table 5: ICL QSFP connector port LEDs

LED purpose	Color	Status	Recommended action
QSFP connector status	No light (LED is off)	No QSFP module, all four QSFP ports are disabled.	No action is required if QSFP not present or verify that the QSFP is fully inserted.
	Steady amber	QSFP module is in, all four ports have no signal/no sync.	No action required if QSFP only is installed or ensure that the cable is properly connected. If the LED remains amber, consult the device supplier.
	Blinking amber	Port is disabled or faulted, FC link activity, segmented, loopback mode, also during transition between MTP cable insertion and confirmation.	Check for console messages or wait for all four ports to come online.
	Steady green	Both ends of MTP cable are in and all ports are online. Full link is established.	No action required.

The following figures illustrate types of MTP cables and transceivers:

- Separate MTP cable and transceiver. The transceiver is inserted into the blade port connector and the cable plugs into a QSFP on the other end of the ICL.

Figure 16: MTP cable and transceiver

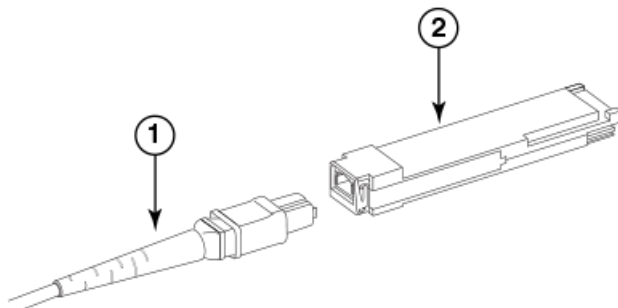

1. MTP cable
2. Transceiver

NOTE

If the fiber optic cables are not connected to transceivers, make sure the rubber gaskets are plugged into the transceivers.

- Brocade 2 km LWL QSFP transceiver with integrated MTP cable. The transceiver is inserted into the blade port connector and integrated cable plugs into a QSFP on the other end of the ICL, a patch panel, or a patch cable.

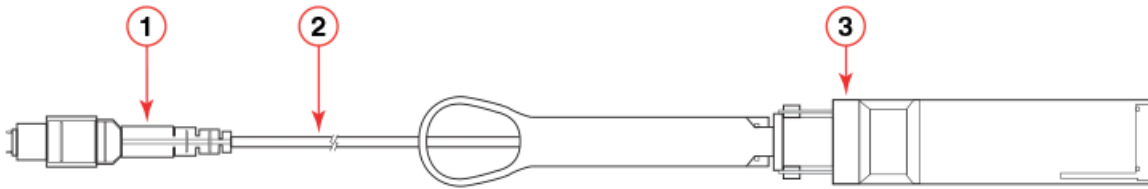
Figure 17: 2 km QSFP with integrated cable

1. MTP 1x12 fiber male connector
2. Integrated 3 meter MTP cable
3. Transceiver with pull-tab

- A third type of transceiver has a pull-tab to aid in removing the transceiver from the port connector (like shown in previous illustration), but has a separate MTP cable that plugs into the transceiver.

The QSFP connectors on the core blades are labeled by trunk group (trunking is optional) for ease of installation.

Possible ICL configurations

The following figures show acceptable cabling configurations for the ICL feature. The recommended topology is the parallel type where there are four QSFP cables connected between any pair of Brocade DCX 8510 series chassis. The full-mesh configuration is also supported. Each of two cores in one chassis should be interconnected with each of two cores in the second chassis. This provides for inter-chassis link (ICL) trunking between chassis, ensuring redundancy. Parallel connections between core blades are recommended.

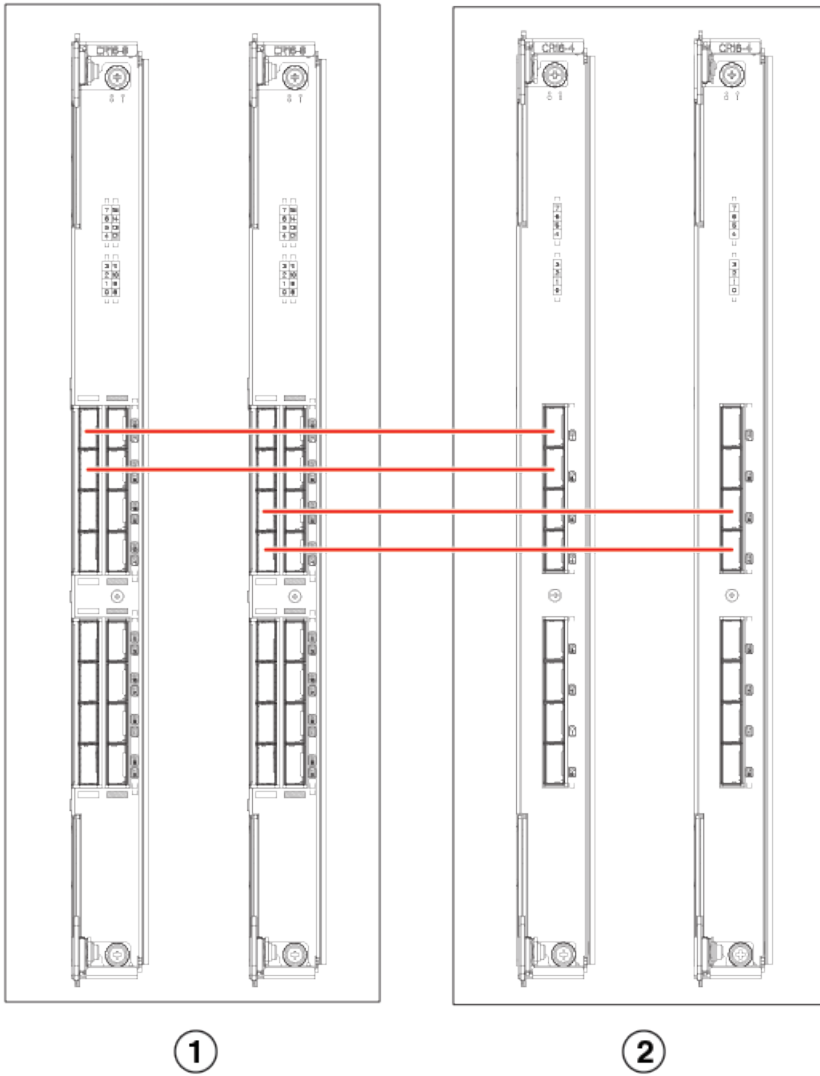
Figure 18: QSFP cable connections for Brocade DCX 8510 chassis (sample configuration)

1. Chassis 1 - DCX 8510-8
2. Chassis 2 - DCX 8510-4

The DCX 8510 chassis can be connected in a core/edge configuration. The following figure shows two core and four edge chassis. Although DCX 8510-8 chassis are shown in the figure, the chassis can be either DCX 8510-4 or DCX 8510-8. The cabling scheme should follow the parallel example shown in the previous figure. Each line in the example actually represents four cables running between the chassis.

Figure 19: DCX 8510 core/edge ICL topology

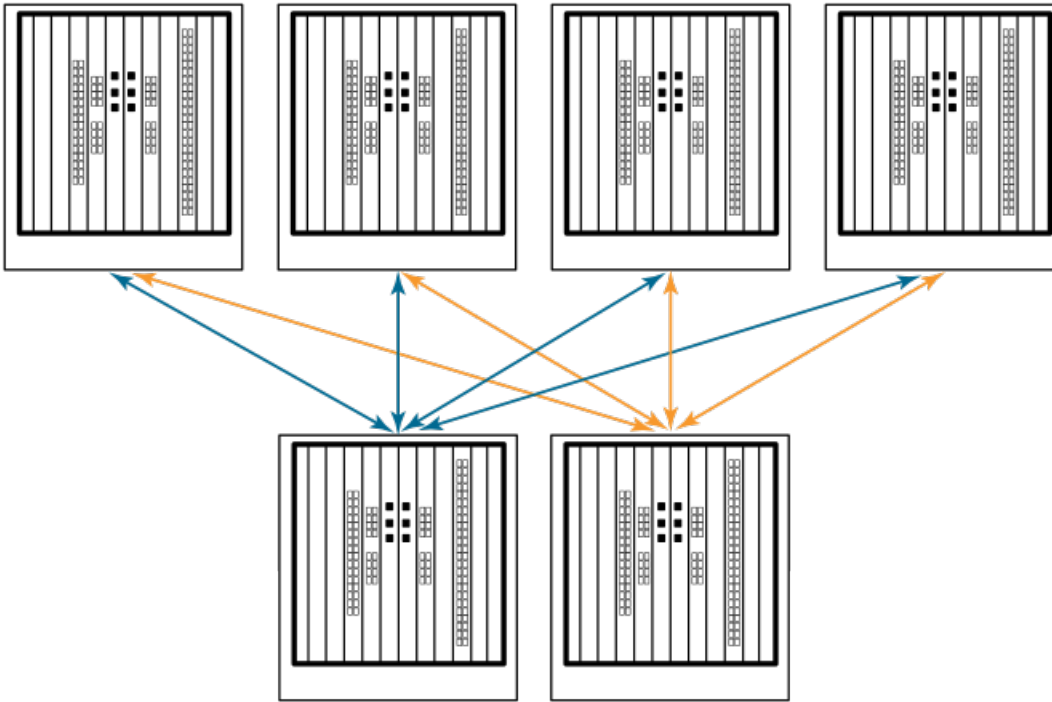

The DCX 8510 chassis can also be connected in a full mesh configuration as shown in the following figure. Although DCX 8510-8 chassis are shown in the figure, the chassis can be either DCX 8510-4 or DCX 8510-8. In this example, the trunk groups are shown in color.

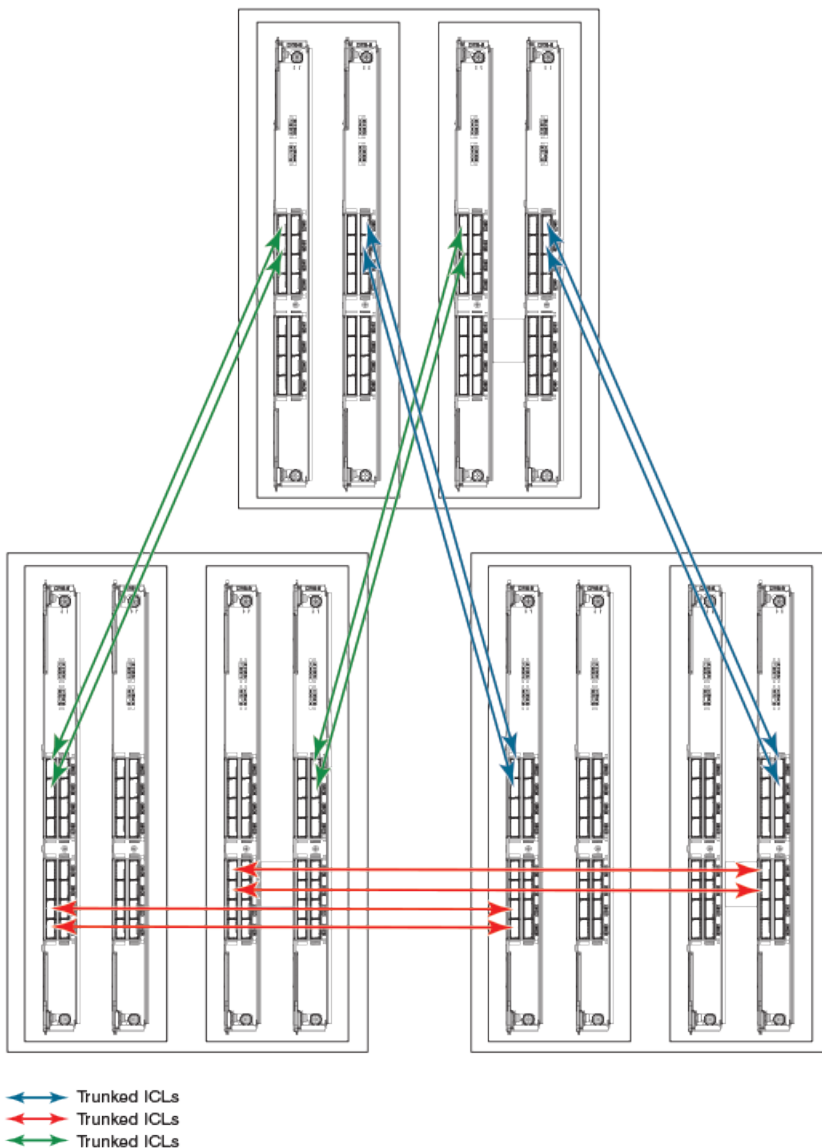
Figure 20: DCX 8510 full mesh ICL topology

Using Brocade 2 km LWL QSFPs

Up to 10 ICL ports using the 2km ICL QSFP are supported in a DCX 8510 backbone switch at the two km distance, which requires configuring 16 buffer credit per virtual channel. The 10 ICL limit is based on the number of buffers. If the 2km QSFPs are used at shorter distances, then more ICLs can be used.

The Brocade 2 km LWL QSFP, is a hot-swappable, low-voltage (3.3 V) digital diagnostic optical transceiver that supports high-speed serial links over parallel single-mode optical fibers at signaling rates up to 4×14.025 Gbps. The QSFP is integrated with a 3-meter ribbon fiber cable with a male MTP 1 x 12 connector. The QSFP supports 2 km link length on parallel single-mode fiber.

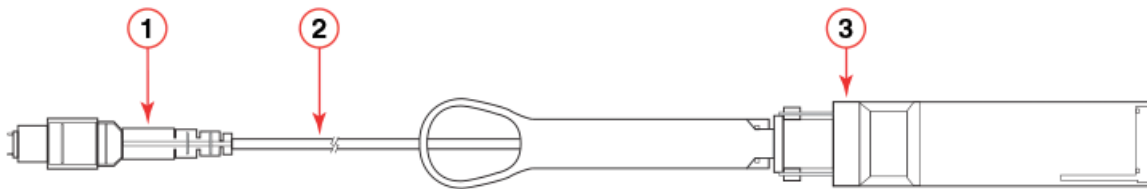
Figure 21: 2 km LWL QSFP transceiver with integrated cable

1. MTP 1 x 12 fiber male connector
2. Integrated 3 meter MTP cable
3. Transceiver with pull-tab

Following are cabling options and recommendations:

- Connect the 3 meter integrated single mode transceiver cable directly to a female-terminated connector in a patch panel or patch cable using a key-up/key-down MPO/MTP coupler.
- Use female-to-female patch cable with the following specifications:
 - Single-mode (not OM3 MMF or OMM MMF)
 - MTP/MPO 1 x 12 fiber
 - MTP female angled polished connector (APC)
 - Key-up/key-up connectors for polarity

Figure 22: Female-to-female patch cable for QFSP connections

Qualified cables for the FC8-64 port blade

The following table lists the third-party cables that have been qualified for use with the mSFP transceivers in the FC8-64 high density port blade.

Table 6: Qualified cables for mSFP connections for the FC8-64 high density port blade

Description	Length	Corning part number	Molex part number	Amphenol part number
Patch cables - mSFP to LC		S50502S5120XXXM (XXX = length)		943-99865-1XXXX (XXXX = length)
mSFP LC - standard LC, duplex, multi-mode, OM3, 50/125	1 m	S50502S5120001M	106273-0525	943-99865-10001
mSFP LC - standard LC, duplex, multi-mode, OM3, 50/125	2 m	S50502S5120002M	106273-0526	943-99865-10002
mSFP LC - standard LC, duplex, multi-mode, OM3, 50/125	3 m	S50502S5120003M	106273-0527	943-99865-10003
mSFP LC - standard LC, duplex, multi-mode, OM3, 50/125	5 m	S50502S5120005M	106273-0528	943-99865-10005

Description	Length	Corning part number	Molex part number	Amphenol part number
mSFP LC - standard LC, duplex, multi-mode, OM3, 50/125	10 m	S5S502S5120010M	106273-0529	943-99865-10010
Patch cables - mSFP to mSFP		S5S502S5120XXXM (XXX = length)		943-99866-1XXXX (XXXX = length)
mSFP LC - mSFP LC, duplex, multi-mode, OM3, 50/125	1 m	S5S502S5120001M	106273-0560	943-99866-10001
mSFP LC - mSFP LC, duplex, multi-mode, OM3, 50/125	2 m	S5S502S5120002M	106273-0561	943-99866-10002
mSFP LC - mSFP LC, duplex, multi-mode, OM3, 50/125	3 m	S5S502S5120003M	106273-0562	943-99866-10003
mSFP LC - mSFP LC, duplex, multi-mode, OM3, 50/125	5 m	S5S502S5120005M	106273-0563	943-99866-10005
mSFP LC - mSFP LC, duplex, multi-mode, OM3, 50/125	10 m	S5S502S5120010M	106273-0564	943-99866-10010
Trunk cables - mSFP to MTP		tbd		
mSFP LC - MTP-female, 12 fiber, 12" breakout, OM3, 50/125		H93S5TE9-BMU-XXXM (XXX = length)		943-99867-1XXXX (XXXX = length)
mSFP LC - MTP-female, 12 fiber, 6" breakout, OM3, 50/125	2 m		106272-0327	
mSFP LC - MTP-female, 24 fiber, 12" breakout, OM3, 50/125	2 m		106272-0328	
Bag of clips (quantity 64)		TRIGGER-BP-NP	n/a	n/a

High-density cabling for the FC8-64 port blade

The FC8-64 high density port blade cannot use the standard LC cables because the pitch between optics in the new mini-SFP (mSFP) transceiver is smaller than in standard SFPs. Patch cables and panels can be used to attach standard size cabling to the blade if necessary. The following figure illustrates the mSFP to SFP patch cable. Refer to "Best Practices Guide: High Density Cable Management Solutions" (available at <http://www.brocade.com>) for cable management guidelines for high-density port solutions, and cable and patch panel part numbers.

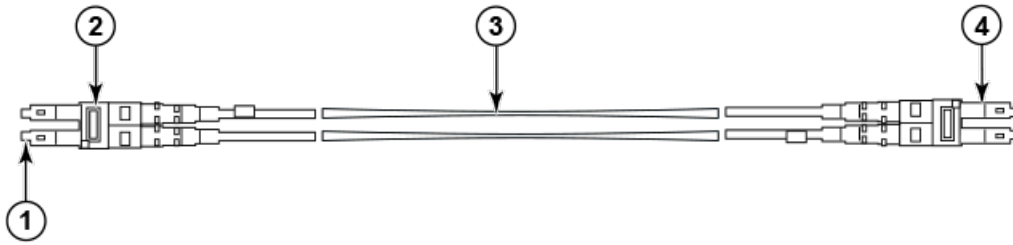
Figure 23: Cable design for the mSFP patch cables for the FC8-64 high density port blade

1. mSFP connector
2. Duplex clip (black)
3. 6 mm cable
4. SFP connector

Note that the duplex clip on the mSFP end of the cable is black for easier recognition. For a listing of the qualified mSFP optical cables for the FC8-64 port blade, refer to [Qualified cables for the FC8-64 port blade](#).

If ISL Trunking is in use, group the cables by trunking group. The ports are color-coded to indicate which ports can be used in the same ISL Trunking group: eight ports marked with solid black ovals alternate with eight ports marked with oval outlines.

Initial Configuration

Items required

The following items are required for initial setup and verification of the device:

- The device, mounted and installed with the required blades, FRUs, transceivers, and cables and is connected to a power source.
- A workstation computer with an installed terminal emulator application, such as HyperTerminal for Windows.
- Unused IP addresses with corresponding subnet mask and gateway addresses for the device and for both management modules (total of three addresses).
- A serial cable (provided) with an RJ-45 connector.
- An RJ-45 to DB-9 adapter.
- Three Ethernet cables (including one spare)
- Access to an FTP server or USB device for backing up (uploading) or downloading the device configuration or collecting `supportsave` output data (optional).
- A Brocade USB drive for collecting `supportsave` output data (optional)

Providing power to the device

For this procedure, refer to the power supply specifications section in the *Brocade DCX 8510 Backbone Technical Specification* for power supply requirements of your chassis.

Complete the following steps to provide power to the chassis.



DANGER

Make sure that the power source circuits are properly grounded, and then use the power cord supplied with the device to connect it to the power source.

1. Connect the AC power cords to the power supply assemblies. Two or four power cords are required depending on electrical service and if the high availability option is selected.
2. Connect the power cords to a power source with voltage of 200 to 240 VAC, 47 to 63 Hz (normally two power cords or as many as four) or optionally to a power source with voltage of 110 to 120 VAC, 47 to 63 Hz (up to four power cords).

NOTE

Use of the high-voltage line (200 to 240 VAC) is highly recommended because of better power-conversion efficiency. A Brocade DCX 8510-8 chassis fully loaded with 16 Gbps port blades (512 ports total) should be supplied with four power supplies connected to 200-240 VAC lines.

3. Switch the AC power switches on the power supplies to I. The AC power switches light green when switched on and power is supplied.

The device performs a power-on self-test (POST) each time it is powered on. POST takes approximately 10 minutes and is complete when the indicator light activity displays the operational state. You can bypass POST by using the `fastBoot` command. You can also disable POST for successive reboots on the device using the `diagDisablePost` command.

NOTE

Do not connect the switch to the network until the IP addresses are configured.

For information about LED patterns, refer to "[Monitoring System Components](#)".

Configuring the device

The device must be configured before it is connected to the fabric, and all of the configuration commands must be entered through the active CP blade. The device configuration includes the following parameters:

- IP address and subnet mask for the chassis
- IP addresses, host names, subnet masks, and gateway addresses for both control processor (CP) blades
- Switch name
- Domain ID for the device (optional)
- WWN for the device

The device WWN is initially set by the factory to match the license ID (which is based on the chassis serial number). The WWN can be changed but the license ID cannot be modified.

The configuration information is mirrored to the standby CP blade, which allows the current configuration to remain available even if the active CP blade fails. The configuration information for the device is stored in the WWN cards and the flash memory of the CP blades. The configuration can be backed up to a workstation (uploaded) and then downloaded to the active CP blade if necessary.

NOTE

If the Brocade FS8-18 encryption blade is installed, refer to the *Fabric OS Encryption Administrator's Guide* for the procedures to configure the encryption functions.

The following figure illustrates the flow of the basic configuration tasks.

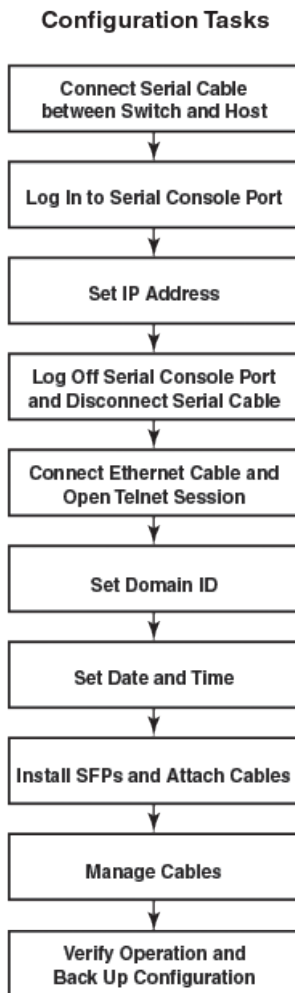
Figure 24: Configuration tasks

Establishing a serial connection to the device

To establish a serial connection to the console port on the device, complete the following steps.

1. Verify that the device is powered on and that POST is complete by verifying that all power LED indicators on the port, control processor, and core switch blades display a steady green light.
2. Remove the shipping cap from the CONSOLE port on the active CP. Use the serial cable provided with the device to connect the CONSOLE port on the active CP to a computer workstation. The active CP blade is indicated by an illuminated (blue) LED.

NOTE

The CONSOLE port is intended primarily for the initial setting of the IP address and for service purposes.

3. Access the device using a terminal emulator application (such as HyperTerminal in a Windows environment or tip in a UNIX environment).
4. Disable any serial communication programs running on the workstation (such as synchronization programs).
5. Open a terminal emulator application (such as HyperTerminal on a PC, or term, tip, or kermi in a UNIX environment), and configure the application as follows:
 - In a Windows environment:

Parameter	Value
Bits per second	9600
Data bits	8
Parity	None
Stop bits	1
Flow control	None

NOTE

Flow control is not supported on the serial consoles when attached to remote terminal servers and must be disabled on the customer-side remote terminal server and the host-side clients.

- In a UNIX environment, enter the following string at the prompt:

```
tip /dev/ttyb -9600
```

If `ttyb` is already in use, use `ttya` instead and enter the following string at the prompt:

```
tip /dev/ttya -9600
```

When the terminal emulator application stops reporting information, press `Enter`. You receive the following login prompt:

```
CP0 Console Login:
```

6. Proceed to the next task.

Logging in to the serial console port

To log in to the device through the serial connection, follow these steps.

1. Log in to the device as `admin`. The default password is `password`. At the initial login, you are prompted to enter new admin and user passwords. Make sure to write down the new passwords and keep this information in a secure location.

```
fabric OS (swDir)
```

```
swDir login: admin
```

```
Password:
```

```
Please change your passwords now.
```

Use Control-C to exit or press 'Enter' key to proceed.

```
swDir:admin>
```

2. (Optional) Modify passwords. To skip modifying the password, press **Ctrl+C**.

NOTE

Passwords can be 8 to 40 characters long. They must begin with an alphabetic character. They can include numeric characters, the period (.), and the underscore (_) only. Passwords are case-sensitive, and they are not displayed when you enter them on the command line. For more information on passwords, refer to the *Brocade Fabric OS Administration Guide*.

Configuring the IP addresses

The device requires three IP addresses, which are configured using the `ipAddrSet` command. IP addresses are required for both CP blades (CP0 and CP1) and for the chassis management IP (shown as SWITCH under the `ipAddrShow` command) in the device.

NOTE

The default IP addresses and host names for the device are:

- 10.77.77.75 / CP0 (the CP blade in slot 6 at the time of configuration)
- 10.77.77.74 / CP1 (the CP blade in slot 7 at the time of configuration)

NOTE

Resetting an IP address while the device has active IP traffic or has management and monitoring tools running, such as DCFM, Fabric Watch, and SNMP, can cause traffic to be interrupted or stopped.

Complete the following steps to set the IP addresses for the device.

1. Log in to the active CP as admin using the serial cable connection.
2. Set up the device IP address by entering the `ipaddrset -chassis` command:

```
swDir:admin> ipAddrSet -chassis
```

Enter the information at the prompts. Specify the `-chassis` IP address. The `-sw 0` IP address is not valid on this chassis.

NOTE

The addresses 10.0.0.0 through 10.0.0.255 are reserved and used internally by the device. External IPs must not use these addresses.

3. Set up the CP0 IP address by entering the `ipaddrset -cp 0` command:

```
swDir:admin> ipAddrSet -cp 0
```

Enter the information at the prompts.

4. Set up the CP1 IP address by entering the `ipaddrset -cp 1` command:

```
swDir:admin> ipAddrSet -cp 1
```

Enter the information at the prompts.

This is a sample IP configuration:

```
swDir:admin> ipaddrset -chassis

Ethernet IP Address [0.0.0.0]: 192.168.1.1

Ethernet Subnetmask [0.0.0.0]: 255.255.255.0

Fibre Channel IP Address [0.0.0.0]:

Fibre Channel Subnetmask [0.0.0.0]:

Issuing gratuitous ARP...Done.

Committing configuration...Done.

swDir:admin>

ipaddrset -cp 0
Host Name [cp0]:
Ethernet IP Address [10.77.77.75]: 192.168.1.2

Ethernet Subnetmask [0.0.0.0

]: 255.255.255.0

Gateway IP Address [0.0.0.0

]: 192.168.1.254

IP address is being changed...Done.
Committing configuration...Done.
swDir:admin> ipaddrset -cp 1
Host Name [cp1]:
Ethernet IP Address [10.77.77.74]: 192.168.1.3

Ethernet Subnetmask [0.0.0.0]: 255.255.255.0

Gateway IP Address [0.0.0.0]: 192.168.1.254

IP address of remote CP is being changed...Done.

Committing configuration...Done.
```

Logging off the serial console port and disconnecting the serial cable

You can use the serial port to monitor error messages through the serial connection. If the serial port is no longer required, use the `logout` command to log out of the serial console, remove the serial cable, and replace the plug in the serial port.

Establishing an Ethernet connection to the device

After using a serial connection to configure the IP addresses for the device, you can connect the active CP blade to the local area network (LAN).

NOTE

Connecting the CP blades to a private network or VLAN is recommended.

By establishing an Ethernet connection, you can complete the device configuration using a serial session, Telnet, or management applications, such as Web Tools or Brocade Network Advisor.

Perform the following steps to establish an Ethernet connection to the device.

1. Remove the shipping plug from the Ethernet port on the active CP blade.
2. Insert one end of an Ethernet cable into the Ethernet port.
3. Connect the other end to an Ethernet 10/100/1000 BaseT LAN.

The device can be accessed through a remote connection using the command line via Telnet or any of the management tools, such as Web Tools or Brocade Network Advisor.

4. To complete any additional device configuration procedures through a Telnet session, log in to the device by Telnet, using the `admin` login. The default password is `password`.

Customizing a switch name

Refer to the considerations and rules for creating switch, fabric, and chassis names listed in the Fabric OS Administration Guide.

NOTE

Changing the name causes a domain address format RSCN to be issued.

1. Enter `switchName` followed by the new name in double quotes.

```
swDir:admin> switchName "swModularSwitch5"

Committing configuration...
Done.
swModularSwitch5:admin>
```

2. Record the new name for reference.

Customizing a chassis name

Refer to the considerations and rules for creating switch, fabric, and chassis names listed in the Fabric OS Administration Guide.

1. Enter `chassisName` followed by the new name in double quotes.

```
switch:admin> chassisname
"DCX8510_chassis"

Committing configuration...
Done.
```

2. Enter `chassisName` by itself to show the name.

```
switch:admin> chassisname
```



```
DCX8510_chassis
```

- Record the new name for reference.

Setting the domain ID

Each switch in the fabric must have a unique domain ID. The domain ID can be manually set through the `configure` command or can be automatically set. The default domain ID for the device is 1. Use the `fabricShow` command to view the already assigned domain IDs.

- Enter `switchDisable` to disable the device.
- Enter `configure`.
- Enter `y` at the *Fabric parameters* prompt:

```
Fabric parameters (yes, y, no, n): [no] y
```

- Enter a unique domain ID:

```
Domain: (1.239) [1] 3
```

- Complete the remaining prompts or press **Ctrl+D** to accept the settings and exit.
- Enter `switchEnable` to re-enable the device.

Setting the date and time

The date and time settings are used for logging events. Switch operation does not depend on the date and time; a switch with an incorrect date and time value still functions properly. However, because the date and time are used for logging, error detection, and troubleshooting, they should be set correctly.

Setting the date

To set the date, follow these steps.

- If necessary, log on to the device by Telnet, using the `admin` account.

The default password is `password`.

- Enter the `date` command, using the following syntax:

```
date "mmddHHMMyy"
```

The values are:

- `mm` is the month; valid values are 01 through 12.
- `dd` is the date; valid values are 01 through 31.
- `HH` is the hour; valid values are 00 through 23.
- `MM` is minutes; valid values are 00 through 59.
- `yy` is the year; valid values are 00 through 99 (values greater than 69 are interpreted as 1970 through 1999, and values less than 70 are interpreted as 2000 through 2069).

```
switch:admin> date  
Fri Sep 28 17:01:48 UTC 2010
```

```
switch:admin> date "0927123010"
Thu Sep 27 12:30:00 UTC 2010
switch:admin>
```

Setting the time zone

You must perform the procedure on *all* chassis for which the time zone must be set. Because the value is written to nonvolatile memory, you only need to set the time zone once on each switch.

Use one of the two following procedures to set the time zone.

The following procedure describes how to set the current time zone using `timezone_fmt` mode to Central Standard time.

1. Log in to the switch using the default password, which is password.
2. Enter the `tsTimeZone` command as follows:

```
switch:admin> tstimezone [ --interactive]/ [, timezone_fmt]
```

Use `timezone_fmt` to set the time zone by Country/City or by time zone ID, such as PST.

The following example shows how to change the time zone to US/Central.

```
switch:admin> tstimezone
Time Zone : US/Pacific
switch:admin> tstimezone US/Central
switch:admin> tstimezone
Time Zone : US/Central
```

The following procedure describes how to set the current time zone using interactive mode to Pacific Standard Time.

1. Enter the `tsTimeZone` command as follows:

```
switch:admin> tstimezone --interactive
```

You are prompted to select a general location.

Please identify a location so that time zone rules can be set correctly.

2. Enter the appropriate number or **Ctrl+D** to quit.
3. At the prompt, select a country location.
4. At the prompt, enter the appropriate number to specify the time zone region or **Ctrl+D** to quit.

Synchronizing local time

To synchronize the local time of the principal or primary switch with that of an external NTP server, follow these steps.

1. If necessary, log on to the switch by Telnet, using the `admin` account.
2. Enter the `tsClockServer` command:

```
switch:admin> tsclockserver
" <ntp1;ntp2>"
```

In this syntax, `ntp1` is the IP address or DNS name of the first NTP server, which the switch must be able to access. The variable `ntp2` is the second NTP server and is optional. The operand "`<ntp1;ntp2>`" is optional; by default, this value is `LOCL`, which uses the local clock of the principal or primary switch as the clock server.

The `tsClockServer` command accepts multiple server addresses in IPv4, IPv6, or DNS name formats. When multiple NTP server addresses are passed, `tsClockServer` sets the first obtainable address as the active NTP server. The

rest will be stored as backup servers that can take over if the active NTP server fails. The principal or primary FCS switch synchronizes its time with the NTP server every 64 seconds.

```
switch:admin> tsclockserver
LOCL
switch:admin> tsclockserver "132.163.135.131"

switch:admin> tsclockserver
132.163.135.131
switch:admin>
```

The following example shows how to set up more than one NTP server using a DNS name:

```
switch:admin> tsclockserver "10.32.170.1;10.32.170.2;ntp.localdomain.net"
Updating Clock Server configuration...done.
Updated with the NTP servers
Changes to the clock server value on the principal or primary FCS switch are propagated to all switches in
the fabric
```

Determining installed software licenses

Depending on the vendor agreement, certain licenses are factory installed on the device. To determine which licenses are enabled, use the `licenseShow` command.

```
swDir:admin> licenseshow
AAbbccDDeeFFeeGG:
  Web license
  Zoning license
  Extended Fabric license
  Fabric Watch license
  Performance Monitor license
  Trunking license
  Security license
```

In this example, the license key is AAbbccDDeeFFeeGG. Keep a copy of the license key for reference.

The 64-bit chassis ID is required to obtain and activate licenses for the device. The chassis ID is available through the `licenseIdShow` command. The `licenseShow` and `licenseIdShow` commands must be entered on the active CP blade. Refer to the *Brocade Fabric OS Administration Guide* for more information.

Installing transceivers and attaching cables

The following two sets of steps cover the installation of transceivers and cables for most SFPs and for QSFPs.

For a list of qualified transceivers for FC16-64 and CR16-x blades, refer to [Qualified transceivers for FC16-64 and CR16-x blades](#).

Installing SFP+ and mSFP transceivers and cables

Complete the following steps to install SFP-type optical transceivers.

NOTE

mSFP transceivers are compatible only with the FC8-64 port blade. While they will fit in other blades, this configuration is unsupported and will generate an error.

NOTE

For current information on qualified transceivers supported by this device, refer to the Brocade Fibre Channel Transceiver Platform Support Matrix and Brocade Transceiver Module Resources on www.brocade.com

NOTE

The device supports only Brocade-qualified transceivers. If you use an unqualified transceiver, the `switchshow` command output shows the port in a `Mod_Inv` state. Fabric OS also logs the issue in the system error log.

1. Add the optical transceivers and cables to the Fibre Channel ports.

The ports are color-coded to indicate which can be used in the same port group for trunking (trunking port groups can be up to 8 ports). The ports and cables used in trunking groups must meet specific requirements. Refer to the *Brocade Fabric OS Administration Guide*.

2. Position one of the optical transceivers so that the key is oriented correctly to the port. Insert the transceiver into the port until it is firmly seated and the latching mechanism clicks.

Transceivers are keyed so that they can only be inserted with the correct orientation. If a transceiver does not slide in easily, ensure that it is correctly oriented.

3. Position a cable so that the key (the ridge on one side of the cable connector) is aligned with the slot in the transceiver. Insert the cable into the transceiver until the latching mechanism clicks.

Cables are keyed so that they can be inserted in only one way. If a cable does not slide in easily, ensure that it is correctly oriented.

4. Repeat steps 1 through 3 for the remaining ports.
5. Organize the cables. Refer to [Managing cables](#).
6. Verify the device and port status using the `switchShow` command.
7. Verify fabric connectivity using the `fabricShow` command.

Qualified transceivers for the FC16-64 and CR16-x blades

The following table shows the qualified transceivers for the FC16-64 port blade and the CR16-4/8 core blades.

Table 7: Qualified transceivers for FC16-64 port blade and the CR16-x core blades

Brocade part number	Part type	Cable length	Port speeds	Supported blades
57-1000310-01	QSFP transceiver with integrated 3 m optical cable	Supports 2 km	16 Gbps	CR16-4/8
57-1000294-02	QSFP transceiver	100 m OM4	Auto-negotiable 4-, 8-, and 16-Gbps	FC16-64 and CR16-4/8
57-1000267-01	QSFP transceiver	100 m OM4	Only fixed 16-Gbps	CR16-4/8
57-0000090-01	QSFP transceiver	50 m OM3	Only fixed 16-Gbps	CR16-4/8

Installing QSFP transceivers and cables

Follow these steps to install the QSFPs and cables in the FC16-64 port blades and the 16-Gbps core blades. In the core blades, these transceivers and cables are used to form the inter-chassis links (ICLs) with neighboring Backbones. The

transceivers should be installed in the blades before connecting the cables. As each QSFP contains four 16-Gbps ports, be aware that any problems with one port could affect all four ports in the quad if the QSFP must be replaced.

1. Position one of the QSFP transceivers so that the key is oriented correctly to the port. Insert the transceiver into the port until it is firmly seated.

Transceivers are keyed so that they can only be inserted with the correct orientation. If a transceiver does not slide in easily, ensure that it is correctly oriented.

When the transceiver is correctly seated, the status LED will flash amber several times and then turn solid amber.

2. Remove the protective cap from the special QSFP cable and insert it into the transceiver until it is firmly seated.

The cables are also keyed to fit into the transceivers correctly.

When the cable is correctly seated, the status LED will change from amber to green.

Repeat steps 1 and 2 for the remaining QSFP ports.

3. Organize the cables. Refer to information on managing cables in this installation guide.
4. Verify the device and connector and port status using the `switchShow -qsfp` command.

NOTE

The following example is from a DCX chassis with four slots for port blades and a core blade installed in slot 3. Some details for a chassis with eight slots for ports blades will display differently, but the reported information for the QSFPs will be similar.

QSFP 7 (ports 3/28-3/31, Index 748-751) in the following example shows the results for a connected QSFP.

```
switch:FID128:admin> switchshow -qsfp
switchName:      switch name
switchType:      142.0
switchState:     Online
switchMode:      Native
switchRole:      Subordinate
switchDomain:    75
switchId:        fffc4b
switchWwn:       10:00:00:05:1e:4f:eb:00
zoning:         ON ( zoning name
)
switchBeacon:   OFF
FC Router:      OFF
Allow XISL Use: OFF
LS Attributes:  [FID: 128, Base Switch: No, Default Switch: Yes, Address Mode 0]
Index Slot Port QSFP  Address Media  Speed  State      Proto
=====
256   3   0   0   -----  id   16G   No_SigDet  FC
257   3   1   0   -----  id   16G   No_SigDet  FC
258   3   2   0   -----  id   16G   No_SigDet  FC
259   3   3   0   -----  id   16G   No_SigDet  FC
260   3   4   1   -----  --   16G   No_Module  FC
261   3   5   1   -----  --   16G   No_Module  FC
262   3   6   1   -----  --   16G   No_Module  FC
263   3   7   1   -----  --   16G   No_Module  FC
264   3   8   2   -----  --   16G   No_Module  FC
265   3   9   2   -----  --   16G   No_Module  FC
266   3  10   2   -----  --   16G   No_Module  FC
```

```

267  3  11  2  -----  --  16G  No_Module  FC
268  3  12  3  -----  --  16G  No_Module  FC
269  3  13  3  -----  --  16G  No_Module  FC
270  3  14  3  -----  --  16G  No_Module  FC
271  3  15  3  -----  --  16G  No_Module  FC
736  3  16  4  -----  --  16G  No_Module  FC
737  3  17  4  -----  --  16G  No_Module  FC
738  3  18  4  -----  --  16G  No_Module  FC
739  3  19  4  -----  --  16G  No_Module  FC
740  3  20  5  -----  --  16G  No_Module  FC
741  3  21  5  -----  --  16G  No_Module  FC
742  3  22  5  -----  --  16G  No_Module  FC
743  3  23  5  -----  --  16G  No_Module  FC
744  3  24  6  -----  --  16G  No_Module  FC
745  3  25  6  -----  --  16G  No_Module  FC
746  3  26  6  -----  --  16G  No_Module  FC
747  3  27  6  -----  --  16G  No_Module  FC
748  3  28  7  -----  id  16G  Online    FC  E-Port  10:00:00:05:1e:39:e4:5a  trunkmaster
name
(Trunk master)
749  3  29  7  -----  id  16G  Online    FC  E-Port  10:00:00:05:1e:39:e4:5a  trunkmaster
name
(Trunk master)
750  3  30  7  -----  id  16G  Online    FC  E-Port  10:00:00:05:1e:39:e4:5a  trunkmaster
name
(Trunk master)
751  3  31  7  -----  id  16G  Online    FC  E-Port  10:00:00:05:1e:39:e4:5a  trunkmaster
name
(Trunk master)

```

NOTE

The State reported for an unconnected QSFP (shown QSFP 0 and Ports 0-3 in the example) is No_SigDet. This is different from the State of No_Synch that is reported for regular SFPs that are unconnected.

Managing Cables

Cables can be organized and managed in a variety of ways, for example, using cable channels on the port sides of the cabinet or patch panels to minimize cable management.

With the vertical orientation of the blades in the Brocade DCX 8510-8, a cable management comb is provided below the blades on the port side.

Following is a list of recommendations:

- Leave at least 1 m (3.28 ft) of slack for each port cable. This provides room to remove and replace the device, allows for inadvertent movement of the rack, and helps prevent the cables from being bent to less than the minimum bend radius.
- The minimum bend radius should be no smaller than ten times the cable radius. The minimum radius to which a 50 micron cable can be bent under full tensile load is 5.1 cm (2 in.). For a cable under no tensile load, that minimum is 3.0 cm (1.2 in.).
- If ISL Trunking is in use, group the cables by trunking group. The ports are color-coded to indicate which ports can be used in the same ISL Trunking group: eight ports marked with solid black ovals alternate with eight ports marked with oval outlines.
- Generally, Velcro[®] type cable restraints are recommended to avoid creating sharp bends in the cables. Do not use tie wraps with optical cables because they are easily overtightened and can damage the optic fibers.
- For easier maintenance, label the fiber-optic cables and record the devices to which they are connected.
- Do not route cables in front of the air exhaust vents.
- Route the cables to the bottom of the Brocade DCX 8510-8 through the cable management comb.
- Keep LEDs visible by routing port cables and other cables away from the LEDs.

NOTE

Refer to "Cabling Best Practices" (available at <http://www.brocade.com>) for cable management guidelines.

For the procedure to install the ICL cables, refer to "[Inter-chassis link \(QSFP\) cable removal and replacement](#)."

Verifying correct operation and backing up the configuration

To verify correct operation and back up the device configuration, follow these steps. For information about LED patterns, refer to information on determining the status of extension, application, or port blades in the "System Monitoring" section.

Complete the following steps to back up the configuration for the device.

1. Check the LEDs to verify that all components are functional.
2. If necessary, log in to the switch by Telnet, using the `admin` account.
3. Verify the correct operation of the device by entering the `switchShow` command from the workstation. This command provides information about switch and port status.
4. Verify the correct operation of the device in the fabric by entering the `fabricShow` command from the workstation. This command provides general information about the fabric.
5. To back up the configuration, run the following two steps:
 - a) Enter the `configupload -vf` command. This command uploads the device's virtual fabric data.
 - b) Enter the `configupload` command. This command uploads the device configuration.
6. You can run the following commands to see additional configuration information that you can copy to a file to save:

- `configShow`
- `ipaddrShow`
- `licenseShow`
- `switchShow`

Alternatively, you can save the configuration file to a Brocade USB device by using the `usbstorage` command.

Observe the following notes about configuration data:

- Passwords are not saved in the configuration file, and are not uploaded during a configuration upload.
- It is recommended that the configuration be backed up on a regular basis to ensure that a complete configuration is available for downloading to a replacement chassis.

Powering off the chassis

Perform the following steps to power off the chassis.

1. Shut down the chassis using the `sysShutdown` command.

```
switch::admin> sysshutdown
This command will shutdown the operating systems on your switch.
You are required to power-cycle the switch in order to restore operation.
Are you sure you want to shutdown the switch [y/n]?y
HA is disabled
Stopping blade 1
Shutting down the blade....
Stopping blade 2
Shutting down the blade....
Stopping blade 8
Shutting down the blade....
Broadcast message from root (pts/1) Tue Aug 23 14:23:06 2010...
The system is going down for system halt NOW !!
```

2. Power off the chassis by flipping the AC power switches on the power supplies to O (LEDs inside AC power switches should turn off). To maintain the ground connections, leave power cords connected to the power supplies and to the electrical outlets.

System Monitoring

Monitoring overview

The Brocade DCX 8510-8 is engineered for reliability and requires no routine operational steps or maintenance. This chapter provides information about determining the status of each component using LEDs and CLI commands. Refer to the *Brocade Web Tools Administration Guide* and the *Brocade Fabric OS Administration Guide* for additional information.

There are two commands that can be especially helpful in monitoring the health of the Brocade DCX 8510-8. These commands are `switchShow` and `chassisShow`.

Note in the `switchShow` command the new `switchType` for the Brocade DCX 8510-8 as well as the 16-Gbps speed identification for capable ports. The output has been truncated to reduce information duplication.

```
DCX_8510_8:admin> switchshow
switchName:      DCX_8510_8
switchType:      120.3
switchState:     Online
switchMode:      Native
switchRole:      Subordinate
switchDomain:    120
switchId:        fffc78
switchWwn:       10:00:00:05:1e:d2:64:00
zoning:          ON (BB)
switchBeacon:    OFF
FC Router:       ON
FC Router BB Fabric ID: 10
Address Mode:    0
Index Slot Port Address Media  Speed  State      Proto
=====
  0   1   0   780000  id    N8    No_Light   FC    Disabled (Switch not ready for EX_Ports)
  1   1   1   780100  id    N8    No_Light   FC    Disabled (Switch not ready for EX_Ports)
  2   1   2   780200  --    N8    No_Module  FC    Disabled (Switch not ready for EX_Ports)
  3   1   3   780300  --    N8    No_Module  FC    Disabled (Switch not ready for EX_Ports)
  4   1   4   780400  id    N8    No_Light   FC    Disabled (Switch not ready for EX_Ports)
  5   1   5   780500  id    N8    No_Light   FC    Disabled (Switch not ready for EX_Ports)
  6   1   6   780600  id    N8    No_Light   FC
  7   1   7   780700  id    4G    No_Light   FC
  8   1   8   780800  --    N8    No_Module  FC
  9   1   9   780900  --    N8    No_Module  FC
 10   1  10   780a00  --    N8    No_Module  FC
 11   1  11   780b00  --    N8    No_Module  FC
 12   1  12   780c00  --    --    Offline    VE    Disabled (Persistent)
 13   1  13   780d00  --    --    Offline    VE
 14   1  14   780e00  --    --    Offline    VE
 15   1  15   780f00  --    --    Offline    VE
 128  1  16   788000  --    --    Offline    VE
 129  1  17   788100  --    --    Offline    VE
 130  1  18   788200  --    --    Offline    VE
 131  1  19   788300  --    --    Offline    VE
 132  1  20   788400  --    --    Offline    VE
```

```

133  1  21  788500  --  --  Offline  VE
134  1  22  788600  --  --  Offline  VE  Disabled (Persistent)
135  1  23  788700  --  --  Offline  VE
136  1  24  788800  --  --  Offline  VE
137  1  25  788900  --  --  Offline  VE
138  1  26  788a00  --  --  Offline  VE
139  1  27  788b00  --  --  Offline  VE
140  1  28  788c00  --  --  Offline  VE
141  1  29  788d00  --  --  Offline  VE
142  1  30  788e00  --  --  Offline  VE
143  1  31  788f00  --  --  Offline  VE
      1  ge0      --  1G  No_Module FCIP  Disabled (10G Mode)
      1  ge1      --  1G  No_Module FCIP  Disabled (10G Mode)
      1  ge2      --  1G  No_Module FCIP  Disabled (10G Mode)
      1  ge3      --  1G  No_Module FCIP  Disabled (10G Mode)
      1  ge4      --  1G  No_Module FCIP  Disabled (10G Mode)
      1  ge5      --  1G  No_Module FCIP  Disabled (10G Mode)
      1  ge6      --  1G  No_Module FCIP  Disabled (10G Mode)
      1  ge7      --  1G  No_Module FCIP  Disabled (10G Mode)
      1  ge8      --  1G  No_Module FCIP  Disabled (10G Mode)
      1  ge9      --  1G  No_Module FCIP  Disabled (10G Mode)
      1  xge0     id  10G  No_Light FCIP
      1  xge1     id  10G  No_Light FCIP
32   3   0  782000  id   N8  No_Light  FC
33   3   1  782100  id   N8  No_Light  FC
34   3   2  782200  --   N8  No_Module  FC
35   3   3  782300  id   N8  No_Light  FC
36   3   4  782400  --   N8  No_Module  FC
37   3   5  782500  --   N8  No_Module  FC
38   3   6  782600  --   N8  No_Module  FC
39   3   7  782700  --   N8  No_Module  FC
40   3   8  782800  id   N8  No_Light  FC
41   3   9  782900  id   N8  No_Light  FC
42   3  10  782a00  --   N8  No_Module  FC
43   3  11  782b00  --   N8  No_Module  FC
44   3  12  782c00  id   N8  No_Light  FC
45   3  13  782d00  id   N8  No_Light  FC
46   3  14  782e00  --   N8  No_Module  FC
47   3  15  782f00  --   N8  No_   3  20  78a400  id   N8  No_Light  FC
165  3  21  78a500  --   N8  No_Module  FC
166  3  22  78a600  id   N8  No_Light  FC
167  3  23  78a700  --   N8  No_Module  FC
168  3  24  78a800  --   N8  No_Module  FC
169  3  25  78a900  id   N8  No_Light  FC
170  3  26  78aa00  --   N8  No_Module  FC
171  3  27  78ab00  --   N8  No_Module  FC
172  3  28  78ac00  --   N8  No_Module  FC
173  3  29  78ad00  --   N8  No_Module  FC
174  3  30  78ae00  --   N8  No_Module  FC
175  3  31  78af00  --   N8  No_Module  FC
288  3  32  78a880  id   N8  No_Light  FC
289  3  33  78a980  id   N8  No_Light  FC
290  3  34  78aa80  id   N8  No_Light  FC

```

291	3	35	78ab80	id	N8	No_Light	FC
292	3	36	78ac80	id	N8	No_Light	FC
293	3	37	78ad80	id	N8	No_Light	FC
294	3	38	78ae80	id	N8	No_Light	FC
295	3	39	78af80	id	N8	No_Light	FC
296	3	40	78a080	id	N8	No_Light	FC
297	3	41	78a180	--	N8	No_Module	FC
298	3	42	78a280	--	N8	No_Module	FC
299	3	43	78a380	--	N8	No_Module	FC
300	3	44	78a480	--	N8	No_Module	FC
301	3	45	78a580	--	N8	No_Module	FC
302	3	46	78a680	--	N8	No_Module	FC
303	3	47	78a780	--	N8	No_Module	FC
800	3	48	782080	id	N8	No_Light	FC
801	3	49	782180	--	N8	No_Module	FC
802	3	50	782280	--	N8	No_Module	FC
803	3	51	782380	id	N8	No_Light	FC
804	3	52	782480	--	N8	No_Module	FC
805	3	53	782580	--	N8	No_Module	FC
806	3	54	782680	--	N8	No_Module	FC
807	3	55	782780	id	N8	No_Light	FC
808	3	56	782880	--	N8	No_Module	FC
809	3	57	782980	--	N8	No_Module	FC
810	3	58	782a80	--	N8	No_Module	FC
811	3	59	782b80	--	N8	No_Module	FC
812	3	60	782c80	--	N8	No_Module	FC
813	3	61	782d80	--	N8	No_Module	FC
814	3	62	782e80	--	N8	No_Module	FC
815	3	63	782f80	--	N8	No_Module	FC
48	4	0	783000	id	N8	No_Light	FC
49	4	1	783100	id	N8	No_Light	FC
50	4	2	783200	id	N8	No_Light	FC
51	4	3	783300	id	N8	No_Light	FC
52	4	4	783400	id	N8	No_Light	FC
53	4	5	783500	id	N8	No_Light	FC
54	4	6	783600	id	N8	No_Light	FC
55	4	7	783700	id	N8	No_Light	FC
56	4	8	783800	id	N8	No_Light	FC
57	4	9	783900	id	N8	No_Light	FC
58	4	10	783a00	id	N8	No_Light	FC
59	4	11	783b00	id	N8	No_Light	FC
60	4	12	783c00	id	N8	No_Light	FC
61	4	13	783d00	id	N8	No_Light	FC
62	4	14	783e00	id	N8	No_Light	FC
63	4	15	783f00	id	N8	No_Light	FC
176	4	16	78b000	id	N8	No_Light	FC
177	4	17	78b100	id	N8	No_Light	FC
178	4	18	78b200	id	N8	No_Light	FC
179	4	19	78b300	id	N8	No_Light	FC
180	4	20	78b400	id	N8	No_Light	FC
181	4	21	78b500	id	N8	No_Light	FC
182	4	22	78b600	id	N8	No_Light	FC
183	4	23	78b700	id	AN	No_Sync	FC

184	4	24	78b800	--	N16	No_Module	FC	
185	4	25	78b900	--	N16	No_Module	FC	
186	4	26	78ba00	--	N16	No_Module	FC	
187	4	27	78bb00	--	N16	No_Module	FC	
188	4	28	78bc00	id	N8	No_Light	FC	
189	4	29	78bd00	id	N8	No_Light	FC	
190	4	30	78be00	id	8	No_Light	FC	
190	4	30	78be00	id	N8	No_Light	FC	
191	4	31	78bf00	id	N8	No_Light	FC	
304	4	32	78b880	--	N16	No_Module	FC	
305	4	33	78b980	--	N16	No_Module	FC	
306	4	34	78ba80	--	N16	No_Module	FC	
307	4	35	78bb80	--	N16	No_Module	FC	
308	4	36	78bc80	--	N16	No_Module	FC	
309	4	37	78bd80	--	N16	No_Module	FC	
310	4	38	78be80	id	N8	No_Light	FC	
311	4	39	78bf80	id	N8	No_Light	FC	
312	4	40	78b080	--	N16	No_Module	FC	
313	4	41	78b180	--	N16	No_Module	FC	
314	4	42	78b280	--	N16	No_Module	FC	
315	4	43	78b380	--	N16	No_Module	FC	
316	4	44	78b480	--	N16	No_Module	FC	
317	4	45	78b580	id	N16	No_Light	FC	
318	4	46	78b680	id	N16	No_Light	FC	
319	4	47	78b780	id	N16	Online	FC	E-Port 10:00:00:05:33:03:2c:00 "DCX4S_130" (upstream)
384	5	0	-----	--	16G	No_Module	FC	
385	5	1	-----	--	16G	No_Module	FC	
386	5	2	-----	--	16G	No_Module	FC	
387	5	3	-----	--	16G	No_Module	FC	
388	5	4	-----	--	16G	No_Module	FC	
389	5	5	-----	--	16G	No_Module	FC	
390	5	6	-----	--	16G	No_Module	FC	
391	5	7	-----	--	16G	No_Module	FC	
392	5	8	-----	--	16G	No_Module	FC	
393	5	9	-----	--	16G	No_Module	FC	
394	5	10	-----	--	16G	No_Module	FC	
395	5	11	-----	--	16G	No_Module	FC	
396	5	12	-----	id	16G	No_SigDet	FC	
397	5	13	-----	id	16G	No_SigDet	FC	
398	5	14	-----	id	16G	No_SigDet	FC	
399	5	15	-----	id	16G	No_SigDet	FC	
400	5	16	-----	id	16G	No_SigDet	FC	
401	5	17	-----	id	16G	No_SigDet	FC	
402	5	18	-----	id	16G	No_SigDet	FC	
403	5	19	-----	id	16G	No_SigDet	FC	
404	5	20	-----	id	16G	No_SigDet	FC	
405	5	21	-----	id	16G	No_SigDet	FC	
406	5	22	-----	id	16G	No_SigDet	FC	
407	5	23	-----	id	16G	No_SigDet	FC	
408	5	24	-----	id	16G	No_SigDet	FC	
409	5	25	-----	id	16G	No_SigDet	FC	
410	5	26	-----	id	16G	No_SigDet	FC	
411	5	27	-----	id	16G	No_SigDet	FC	

```

 412   5  28  -----  id   16G  No_SigDet  FC
 413   5  29  -----  id   16G  No_SigDet  FC
 414   5  30  -----  id   16G  No_SigDet  FC
 415   5  31  -----  id   16G  No_SigDet  FC
1152   5  32  -----  --   16G  No_Module  FC
1153   5  33  -----  --   16G  No_Module  FC
1154   5  34  -----  --   16G  No_Module  FC
1155   5  35  -----  --   16G  No_Module  FC
1156   5  36  -----  --   16G  No_Module  FC
1157   5  37  -----  --   16G  No_Module  FC
1158   5  38  -----  --   16G  No_Module  FC
1159   5  39  -----  --   16G  No_Module  FC
1160   5  40  -----  --   16G  No_Module  FC
1161   5  41  -----  --   16G  No_Module  FC
1162   5  42  -----  --   16G  No_Module  FC
1163   5  43  -----  --   16G  No_Module  FC
1164   5  44  -----  --   16G  No_Module  FC
1165   5  45  -----  --   16G  No_Module  FC
1166   5  46  -----  --   16G  No_Module  FC
1167   5  47  -----  --   16G  No_Module  FC
1168   5  48  -----  --   16G  No_Module  FC
1169   5  49  -----  --   16G  No_Module  FC
1170   5  50  -----  --   16G  No_Module  FC
1171   5  51  -----  --   16G  No_Module  FC
1172   5  52  -----  --   16G  No_Module  FC
1173   5  53  -----  --   16G  No_Module  FC
1174   5  54  -----  --   16G  No_Module  FC
<output truncated>
DCX_8510_8:admin>

```

Note in the `chassisShow` command the Chassis Family designation for the Brocade DCX 8510-8 along with specific information about every field-replaceable unit in the chassis.

```

DCX_8510_8:admin> chassisshow
Chassis Family:          DCX8510-8
Chassis Backplane Revision: 0
AP BLADE Slot: 1
Header Version:         2
Power Consume Factor:   -250
Factory Part Num:       60-1001157-21
Factory Serial Num:     ATM0427F01F
Manufacture:            Day: 12 Month: 7 Year: 2010
Update:                 Day: 27 Month: 3 Year: 2011
Time Alive:             45 days
Time Awake:             0 days
SW BLADE Slot: 3
Header Version:         2
Power Consume Factor:   -130
Factory Part Num:       60-0000071-07
Factory Serial Num:     BAH0344E01G
Manufacture:            Day: 2 Month: 11 Year: 2009
Update:                 Day: 7 Month: 2 Year: 2011

```

Time Alive: 280 days
Time Awake: 0 days
SW BLADE Slot: 4
Header Version: 2
Power Consume Factor: -160
Power Usage (Watts): -100
Factory Part Num: 60-1002144-02
Factory Serial Num: BQB0349F00G
Manufacture: Day: 10 Month: 12 Year: 2010
Update: Day: 28 Month: 3 Year: 2011
Time Alive: 14 days
Time Awake: 0 days
CP BLADE Slot: 6
Header Version: 2
Power Consume Factor: -40
Factory Part Num: 60-1000376-08
Factory Serial Num: AHJ0449E042
Manufacture: Day: 14 Month: 12 Year: 2009
Update: Day: 28 Month: 3 Year: 2011
Time Alive: 299 days
Time Awake: 0 days
CP BLADE Slot: 7
Header Version: 2
Power Consume Factor: -40
Factory Part Num: 60-1000376-08
Factory Serial Num: AHJ0448E0AK
Manufacture: Day: 15 Month: 12 Year: 2009
Update: Day: 28 Month: 3 Year: 2011
Time Alive: 312 days
Time Awake: 0 days
CORE BLADE Slot: 5
Header Version: 2
Power Consume Factor: -240
Power Usage (Watts): -154
Factory Part Num: 60-1002140-02
Factory Serial Num: BPZ0349F00G
Manufacture: Day: 7 Month: 12 Year: 2010
Update: Day: 28 Month: 3 Year: 2011
Time Alive: 49 days
Time Awake: 0 days
CORE BLADE Slot: 8
Header Version: 2
Power Consume Factor: -240
Power Usage (Watts): -148
Factory Part Num: 60-1002140-02
Factory Serial Num: BPZ0349F006
Manufacture: Day: 7 Month: 12 Year: 2010
Update: Day: 28 Month: 3 Year: 2011
Time Alive: 46 days
Time Awake: 0 days
SW BLADE Slot: 11
Header Version: 2
Power Consume Factor: -160

```
Power Usage (Watts):    -115
Factory Part Num:      60-1002144-02
Factory Serial Num:    BQB0345F00T
Manufacture:           Day: 11  Month: 11  Year: 2010
Update:                Day: 28  Month:  3  Year: 2011
Time Alive:           30 days
Time Awake:           0 days
SW BLADE Slot: 12
Header Version:        2
Power Consume Factor:  -160
Power Usage (Watts):  -79
Factory Part Num:      60-1002144-02
Factory Serial Num:    BQB0345F012
Manufacture:           Day: 20  Month: 11  Year: 2010
Update:                Day: 28  Month:  3  Year: 2011
Time Alive:           3 days
Time Awake:           0 days
POWER SUPPLY Unit: 1
Header Version:        2
Power Consume Factor:  2000
Factory Part Num:      23-0000067-01
Factory Serial Num:    AGC2M44EKPH
Manufacture:           Day: 29  Month: 12  Year: 2009
Update:                Day: 28  Month:  3  Year: 2011
Time Alive:           319 days
Time Awake:           0 days
POWER SUPPLY Unit: 3
Header Version:        2
Power Consume Factor:  2000
Factory Part Num:      23-0000067-01
Factory Serial Num:    AGC2M44EKPL
Manufacture:           Day: 29  Month: 12  Year: 2009
Update:                Day: 28  Month:  3  Year: 2011
Time Alive:           319 days
Time Awake:           0 days
FAN Unit: 1
Header Version:        2
Power Consume Factor:  -126
Factory Part Num:      60-1000384-09
Factory Serial Num:    AGB0652E0HA
Manufacture:           Day: 29  Month: 12  Year: 2009
Update:                Day: 28  Month:  3  Year: 2011
Time Alive:           319 days
Time Awake:           0 days
FAN Unit: 2
Header Version:        2
Power Consume Factor:  -126
Factory Part Num:      60-1000384-09
Factory Serial Num:    AGB0652E0H9
Manufacture:           Day: 29  Month: 12  Year: 2009
Update:                Day: 28  Month:  3  Year: 2011
Time Alive:           319 days
Time Awake:           0 days
```

```
FAN Unit: 3
Header Version:      2
Power Consume Factor: -126
Factory Part Num:    60-1000384-09
Factory Serial Num:  AGB0652E0H8
Manufacture:         Day: 29 Month: 12 Year: 2009
Update:              Day: 28 Month:  3 Year: 2011
Time Alive:          319 days
Time Awake:          0 days
WWN Unit: 1
Header Version:      2
Power Consume Factor: -1
Factory Part Num:    60-1000491-05
Factory Serial Num:  AFX0602F001
Manufacture:         Day: 29 Month: 12 Year: 2009
Update:              Day: 28 Month:  3 Year: 2011
Time Alive:          319 days
Time Awake:          0 days
ID:                  BRD0000CA
Part Num:            SLKWRM0000DCX
WWN Unit: 2
Header Version:      2
Power Consume Factor: -1
Factory Part Num:    60-1000491-05
Factory Serial Num:  AJX0446E009
Manufacture:         Day: 29 Month: 12 Year: 2009
Update:              Day: 28 Month:  3 Year: 2011
Time Alive:          319 days
Time Awake:          0 days
Chassis Factory Serial Num: AFY0601F007
DCX_8510_8:admin>
```

Determining the status of a port, application, or extension blade

Use the following procedure to determine the status of a blade.

1. Check the LEDs on the blade.

The LED patterns may temporarily change during POST and other diagnostic tests. For information about how to interpret the LED patterns, refer to the table following the blade descriptions.

2. Check the blade status by entering `slotShow`.

FC8-32E port blade LEDs

Figure 25: FC8-32E port blade LEDs

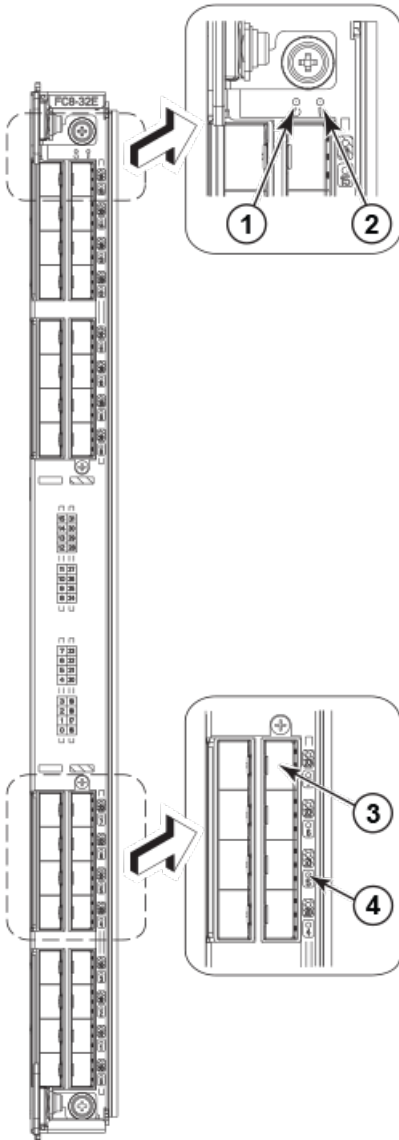

- 1. Blade power LED
- 2. Blade status LED
- 3. Fibre Channel port
- 4. Port status LED

FC8-48E port blade LEDs

Figure 26: FC8-48E port blade LEDs

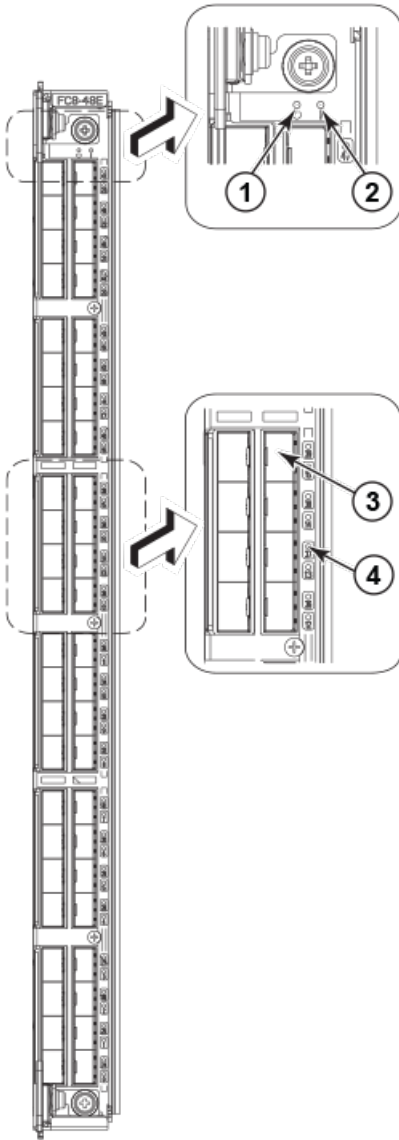

1. Blade power LED
2. Blade status LED
3. Fibre Channel port
4. Port status LED

FC8-64 port blade LEDs

Figure 27: FC8-64 port blade LEDs

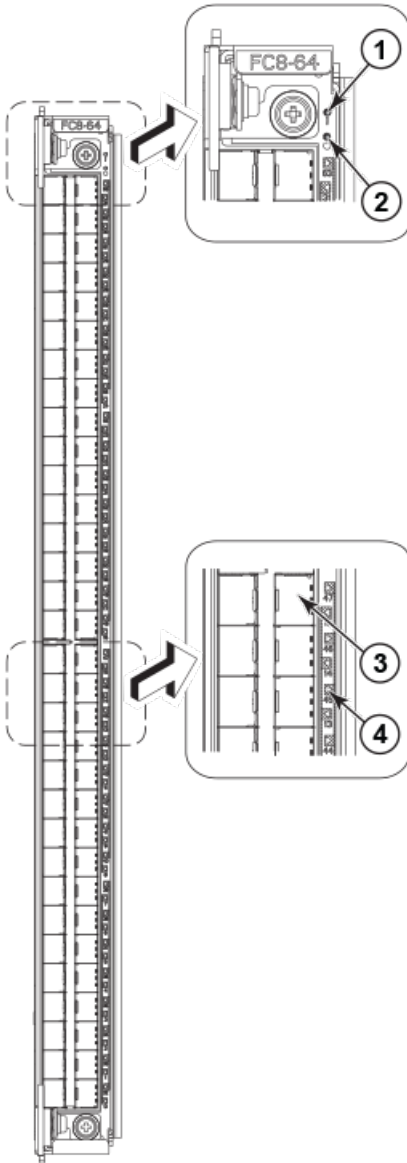

1. Blade status LED
2. Blade power LED
3. Fibre Channel port
4. Port status LED

FC16-32 port blade LEDs

Figure 28: FC16-32 port blade LEDs

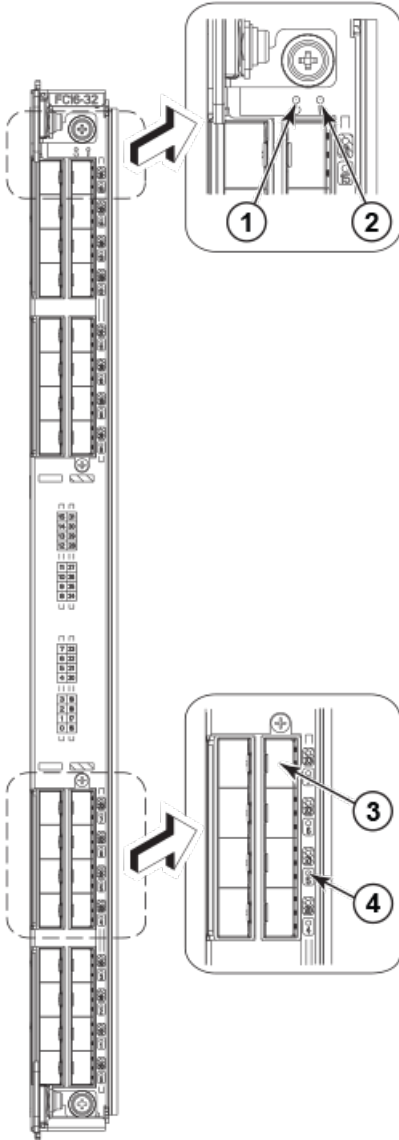

1. Blade power LED
2. Blade status LED
3. Fibre Channel port
4. Port status LED

FC16-48 port blade LEDs

Figure 29: FC16-48 port blade LEDs

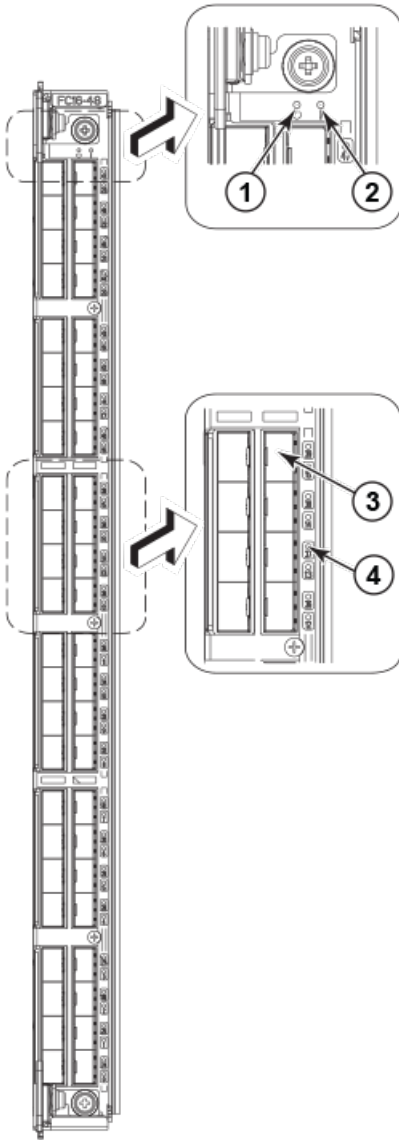

1. Blade power LED
2. Blade status LED
3. Fibre Channel port
4. Port status LED

FC16-64 port blade LEDs

Figure 30: FC16-64 port blade LEDs

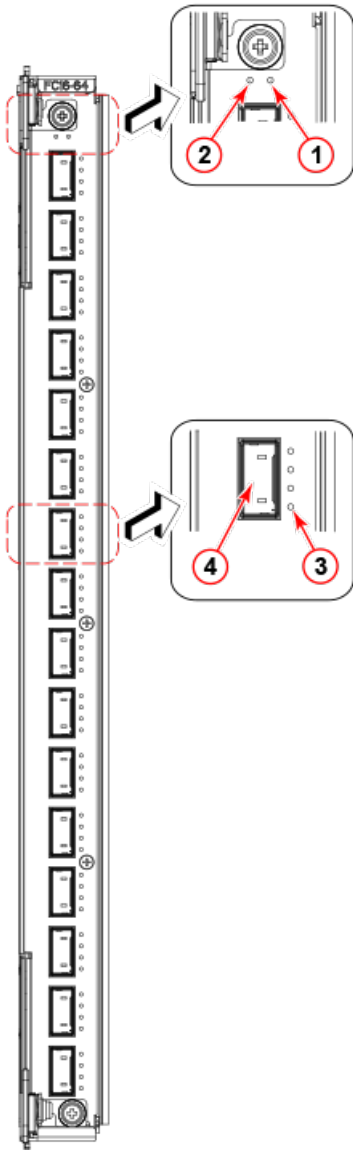

1. Blade power LED
2. Blade status LED
3. Port status LED for FC port 36
4. QSFP port 9; FC ports 36-39 (bottom to up)

FCOE10-24 FCoE blade LEDs

Figure 31: FCOE10-24 FCoE blade LEDs

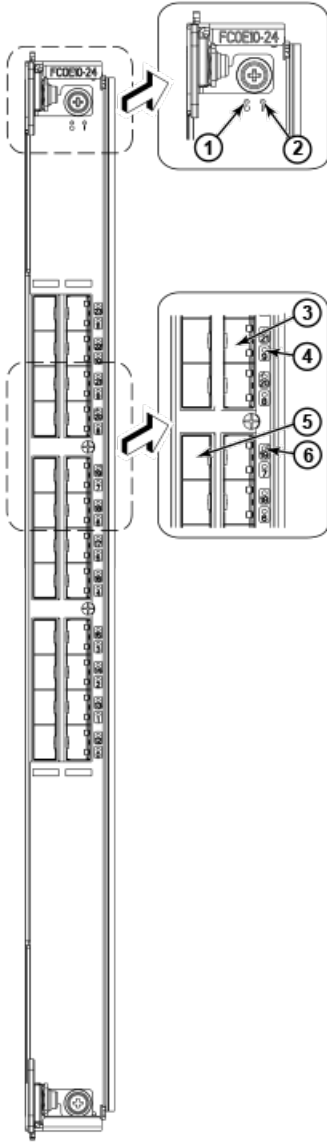

1. Blade power LED
2. Blade status LED
3. 10 GbE FCoE/CEE port 9
4. 10 GbE FCoE/CEE port 9 LED
5. 10 GbE FCoE/CEE port 19
6. 10 GbE FCoE/CEE port 19 LED

FS8-18 encryption blade LEDs

Figure 32: FS8-18 encryption blade LEDs

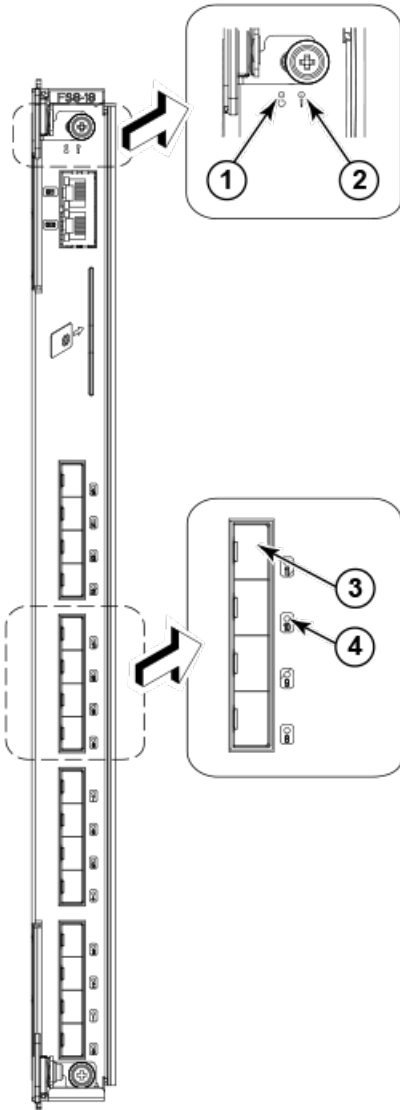

- 1. Blade power LED
- 2. Blade status LED
- 3. Fibre Channel port
- 4. Port status LED

FX8-24 extension blade LEDs

Figure 33: FX8-24 extension blade LEDs

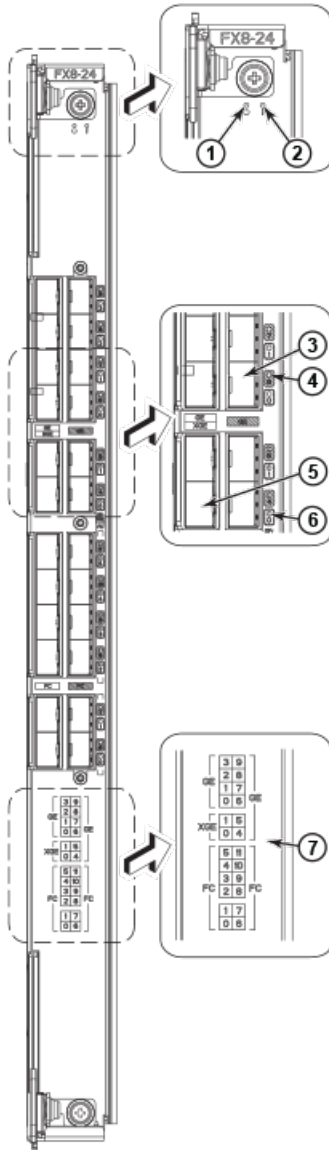

1. Blade power LED
2. Blade status LED
3. GbE port 6
4. GbE port 6 LED
5. 10-GbE port 0
6. 10-GbE port 0 LED
7. Port map

Port, application, and extension blade power LED description

The following table describes the port, application, and extension blade power LED patterns and the recommended actions for those patterns.

Table 8: Port, application, and extension blade power LED description

LED purpose	Color	Status	Recommended action
Power LED 	Steady green	Blade is enabled.	No action required.
	No light (LED is off)	Blade is not powered on.	Ensure that the blade is firmly seated and either the thumbscrew is fully engaged or the slider is pushed up and the ejectors are fully engaged.

Port blade status LED description

The following table describes the port and application blades status LED patterns and the recommended actions for those patterns.

Table 9: Port and application blades status LED description

LED purpose	Color	Status	Recommended action
Status LED 	No light (LED is off)	Blade is either healthy or does not have power.	Verify that the power LED is on.
	Steady amber	Blade is faulty.	Ensure that the blade is firmly seated and check the status by entering the <code>slotShow</code> command. If LED remains amber, consult the device supplier.
	Slow-flashing amber (on 2 seconds, then off 2 seconds)	Blade is not seated correctly or is faulty.	Pull the blade out and reseal it. If LED continues to flash, replace the blade.
	Fast-flashing amber (on 1/2 second, then off 1/2 second)	Environmental range exceeded.	Check for out-of-bounds environmental condition and correct it.

FC ports status LED description

The following table describes blade FC ports status LED patterns and the recommended actions for those patterns.

Table 10: FC ports status LED description

LED purpose	Color	Status	Recommended action
FC Port Status	No light (LED is off)	Port has no incoming power, or there is no light or signal carrier detected.	Verify that the power LED is on, check the transceiver and cable.
		Polling is in progress.	Allow 60 seconds for polling to complete.
		Connected device is configured in an offline state.	Verify the status of the connected device.

LED purpose	Color	Status	Recommended action
	Steady green	Port is online (connected to an external device) but has no traffic.	No action required.
	Slow-flashing green (on 1 second, then off 1 second)	Port is online but segmented, indicating a loopback plug or cable or an incompatible switch.	Verify that the correct device is attached to the chassis.
	Fast-flashing green (on 1/4 second, then off 1/4 second)	Port is in internal loopback (diagnostic).	No action required.
	Flickering green	Port is online, with traffic flowing through port.	No action required.
	Steady amber	Port is receiving light or signal carrier, but it is not online yet.	Reset the port from the workstation using the <code>portEnable</code> or <code>portCfgPersistentEnable</code> command.
	Slow-flashing amber (on 2 seconds, then off 2 seconds)	Port is disabled due to diagnostic tests or <code>portDisable</code> or <code>portCfgPersistentEnable</code> command.	Reset the port from the workstation using the <code>portEnable</code> or <code>portCfgPersistentEnable</code> command.
	Fast-flashing amber (on 1/2 second, then off 1/2 second)	Transceiver or port is faulty.	Change the transceiver or reset the switch from the workstation.
	Alternating green/amber	Port is bypassed.	Reset the port from the workstation using the <code>portEnable</code> or <code>portCfgPersistentEnable</code> command.

GbE and 10-GbE ports status LED description

The following table describes blade GbE and 10-GbE port status LED patterns and the recommended actions for those patterns.

Table 11: 1-GbE and 10-GbE port status LED description

LED purpose	Color	Status	Recommended action
GbE Port Status both 1-GbE and 10-GbE ports	No light (LED is off)	Port has no incoming power, or there is no light or signal carrier detected.	Verify that the power LED is on, check the transceiver and cable.
	Steady green	Port is online but has no traffic.	No action required.
	Slow-flashing green (on 1 second, then off 1 second)	Beacon. Used to identify specific ports.	No action required.
	Flickering green	Port is online, with traffic flowing through port.	No action required.
	Fast-flashing amber (on 1/4 second, then off 1/4 second)	Transceiver or port is faulty.	Change the transceiver or reset the switch from the workstation.

Determining the status of a control processor blade (CP8)

Complete the following steps to determine the status of a control processor blade (CP8)

1. Check the LED indicators on the CP blade. The LED patterns may temporarily change during POST and other diagnostic tests. For information about how to interpret the LED patterns, refer to the following table.
2. Check the port blade status by entering `slotShow` and `haShow`.

Figure 34: Control processor blade (CP8)

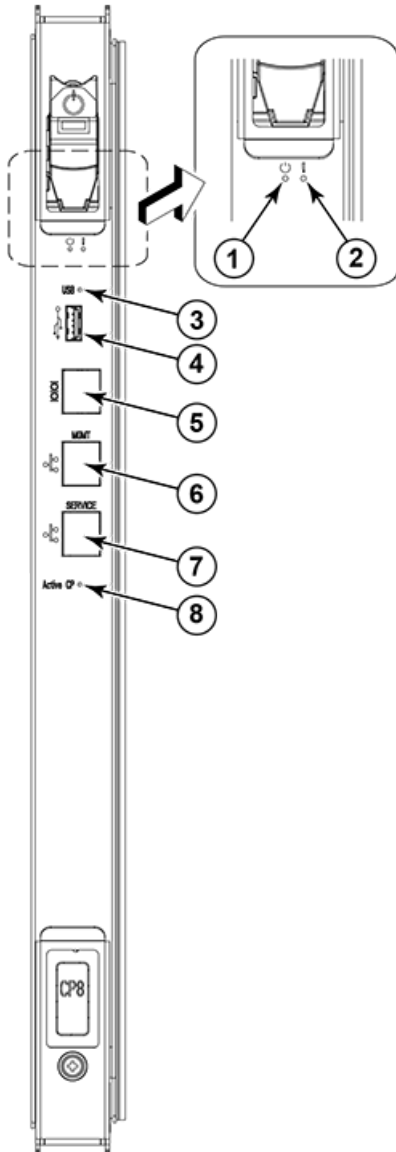



1. Power LED
2. Status LED
3. USB LED
4. USB port
5. Console port (Serial)
6. Ethernet port (Mgmt IP)

7. Ethernet port (Service IP)
8. Active CP LED

The following table describes the CP blade LED patterns and the recommended actions for those patterns.

Table 12: CP blade LED descriptions

LED purpose	Color	Status	Recommended action
Power 	Steady green	CP blade is on.	No action required.
	No light (LED is off)	CP blade is not on.	Ensure that the blade is firmly seated and has power.
Status 	No light (LED is off)	CP blade is either healthy or does not have power.	Verify that the power LED is on.
	Steady amber	CP blade is faulty or the switch is still booting.	Ensure that the blade is firmly seated and the switch has completed booting. If LED remains amber, consult the device supplier.
	Slow-flashing amber (on 2 seconds, then off 2 seconds)	CP blade is not seated correctly or is faulty.	Pull the blade out and reseal it. If the LED continues to flash, replace the blade.
	Fast-flashing amber (on 1/2 second, then off 1/2 second)	Environmental range exceeded.	Check for out-of-bounds environmental condition and correct it.
Ethernet Link Status	No light (LED is off)	Either an Ethernet link is not detected, or it does not have incoming power.	Ensure that the blade has power, the Ethernet cable is firmly seated, and the connected device is functioning.
	Flickering green/amber	Ethernet link is healthy and traffic is flowing through port.	No action required.
Ethernet Link Speed	No light (LED is off)	Ethernet link speed is 10 Mb/s or CP blade does not have incoming power.	Ensure that the CP has power. NOTE: To force a persistent Ethernet link speed, enter the <code>ifModeSet</code> command.
	Steady green	Ethernet link speed is 100/1000 Mb/s.	No action required.
USB Status	Lamp on	USB stick enabled.	No action required.
	Lamp off	USB stick not present or disabled.	No action required.
Active CP	Steady blue	Active CP blade.	No action required.
	No light (LED is off)	Standby CP blade.	No action required.

Determining the status of a core switch blade (CR16-8)

Complete the following steps to determine the status of a core switch blade (CR16-8).

1. Check the LED indicators on the core switch blade. The LED patterns may temporarily change during POST and other diagnostic tests. For information about how to interpret the LED patterns, refer to the following table.
2. Check the core switch blade status by entering `slotShow` and `haShow`.

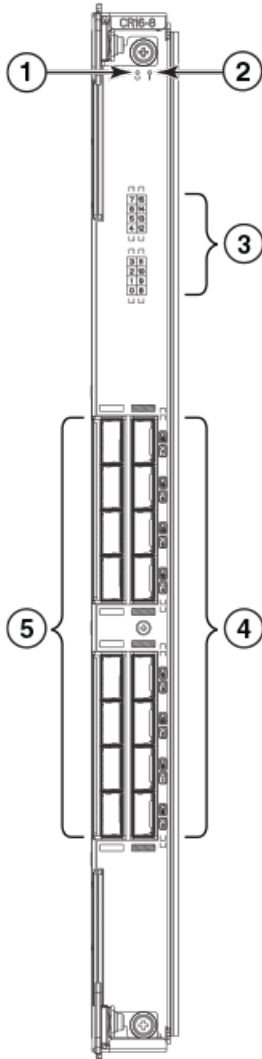

Figure 35: Core switch blade (CR16-8)



1. Power LED
2. Status LED
3. QSFP port map and trunking diagram
4. QSFP connectors
5. QSFP connectors

The following table describes the core switch blade LED patterns and the recommended actions for those patterns.

Table 13: CR blade LED descriptions

LED purpose	Color	Status	Recommended action
Power 	Steady green	CR16-8 blade is on.	No action required.
	No light (LED is off)	CR16-8 blade is not on.	Ensure that the blade is firmly seated and has power.
Status 	No light (LED is off)	CR16-8 blade is either healthy or does not have power.	Verify that the power LED is on.
	Steady amber	CR16-8 blade is faulty or the switch is still booting.	Ensure that the blade is firmly seated and the switch has completed booting. If the LED remains amber, consult the supplier for your Brocade device.
	Slow-flashing amber (on 2 seconds, then off 2 seconds)	CR16-8 blade is not seated correctly or is faulty.	Pull the blade out and reseal it. If the LED continues to flash, replace the blade.
	Fast-flashing amber (on 1/2 second, then off 1/2 second)	Environmental range exceeded.	Check for out-of-bounds environmental condition and correct it.
QSFP connector status LED	No light (LED is off)	No QSFP module, all four QSFP ports are disabled	No action needed if the QSFP is not installed or verify that the QSFP is fully inserted.
	Steady amber	QSFP module is in, all four ports have no signal/no sync.	Ensure that the cable is properly connected. If the LED remains amber, consult the supplier for your Brocade device.
	Blinking amber	Port is disabled or faulted, FC link activity, segmented, loopback mode, also during transition between cable plug in and all four ports online.	Check for console messages or wait for all four ports to come online.
	Steady green	QSFP module is in and all ports are online.	No action needed.

Refer to the Port Numbering section of this guide for a map of the ports and a table of external ports to internal ports as shown in the `slotShow` command.

Determining the status of a power supply

Complete the following steps to determine the status of a power supply. The Brocade DCX 8510-8 can have up to four power supplies.

1. Check the LED indicator on the power supply. The LED patterns may temporarily change during POST and other diagnostic tests; for information about how to interpret the LED patterns, refer to the following table. Be sure to check all the power supply modules.
2. Check the power supply status by entering `psShow`.

The power supply status displays OK, Absent, or Faulty. If a power supply displays absent or faulty, contact the device supplier to order replacement parts. Both physically absent or faulty could also be the result of the power supply not being properly seated or being turned off.

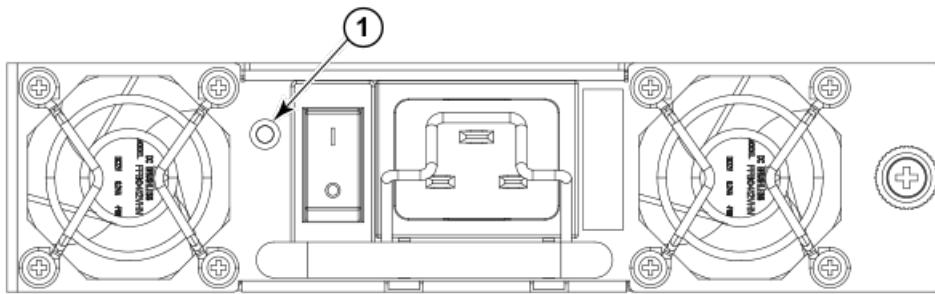
Figure 36: Power supply

1. Power LED

The following table describes the power supply LED patterns and the recommended actions for those patterns.

Table 14: Power supply LED descriptions

LED purpose	Color	Status	Recommended action
Power 	No light (LED is off)	Power supply does not have incoming power and is not providing power to the device.	Ensure that the power supply is firmly seated, the device has incoming power, both power cables are connected, and AC power switches are on.
	Steady green	Power supply has incoming power and is providing power to the device.	No action required.
	Flashing green	Power supply is about to fail.	Replace the power supply.

Determining the status of a blower assembly

Complete the following steps to determine the status of a blower assembly. The Brocade DCX 8510-8 has three blowers.

1. Check the LED indicators on the blower assembly. The LED patterns may temporarily change during POST and other diagnostic tests; for information about how to interpret the LED patterns, refer to the following table. Be sure to check all the blower modules.
2. Check the blower assembly status using the `fanShow` command.

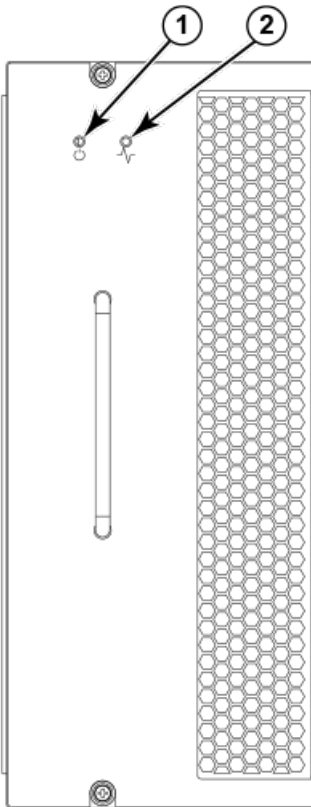

The status for each blower assembly displays OK, Absent, or Faulty. The RPM of each fan in the assembly is also provided. If a blower assembly displays absent or faulty, contact the device supplier to order replacement parts. Both physically absent or faulty could also be the result of the power supply not being properly seated.

Figure 37: Blower assembly

1. Power LED
2. Fault LED

The following table describes the LED patterns for the blower assembly.

Table 15: Blower assembly LED descriptions

LED purpose	Color	Status	Recommended action
Power 	No light (LED is off)	Blower assembly does not have power.	Ensure that the blower assembly is firmly seated and has power.
	Steady green	Blower assembly has power.	No action required.
Fault 	No light (LED is off)	Blower assembly is either healthy or does not have power.	Ensure that the blower assembly has power.
	Steady amber	Blower assembly has a failure (full or partial).	Replace the blower assembly.
	Slow-flashing amber (on 2 seconds, then off 2 seconds)	Blower assembly is not seated correctly or is faulty.	Pull the unit out and reseal it. If the LED continues to flash, replace the unit.
	Flashing amber (on 1/2 second, then off 3.5 seconds)	Fan is disabled.	Run the <code>fanEnable</code> command to enable the fan.

LED purpose	Color	Status	Recommended action
	Fast-flashing amber (on 1/2 second, then off 1/2 second)	Environmental range exceeded.	Check for out-of-bounds environmental condition, resolve any problems, and reset the unit. If the LED continues to flash, replace the unit.

Determining the status of a WWN card

Complete the following steps to determine the status of a WWN card.

NOTE

The WWN bezel (logo plate) covers the WWN cards.

1. Enter the `chassisShow` command to display information about the WWN card. (WWN units correspond to information specific to the WWN card.) Error messages that may indicate problems with a WWN card are summarized in the following table.

Table 16: Messages that may indicate WWN card failure

Type of message	Sample error message
WWN unit fails its field-replaceable unit (FRU) header access.	0x24c (fabos): Switch: switchname, error EM-I2C_TIMEOUT, 2, WWN 1 I2C timed out: state 0x4
WWN unit fails to power on.	<timestamp>, [EM-1004], <sequence-number>,, CRITICAL, <system-name>, WWN # failed to power on or <timestamp>, [EM-1043], <sequence-number>,, WARNING, <system-name>, Can't power <FRU Id> <state (on or off)>.
WWN unit is being faulted.	0x24c (fabos): Switch: switchname, Critical EM-WWN_UNKNOWN, 1, Unknown WWN #2 is being faulted or <timestamp>, [EM-1003], 40, SLOT 7 FFDC CHASSIS, CRITICAL, Brocade_DCX, WWN 2 has unknown hardware identifier: FRU faulted or <timestamp>, [EM-1034], <sequence-number>,, ERROR, <system-name>, WWN # set to faulty, rc=<return code>

Type of message	Sample error message
WWN unit is not present or is not accessible.	0x24c (fabos): Switch: switchname, Error EM-WWN_ABSENT, 2, WWN #1 not presenter<timestamp>, [EM-1036], <sequence-number>,, WARNING, <system- name>, <FRU Id> is not accessible.
Writing to the FRU history log (hilSetFruHistory) has failed.	0x24c (fabos): Switch: switchname, Error EM-HIL_FAIL, 2, HIL Error: hilSetFruHistory failed, rc=-3 for SLOT 3
WWN unit insertion was detected.	<timestamp>, [EM-1049], <sequence-number>,, INFO, <system-name>, FRU WWN # insertion detected.
WWN unit removal was detected.	<timestamp>, [EM-1050], <sequence-number>,, INFO, <system-name>, FRU WWN # removal detected.

2. Check the LED indicators on the WWN bezel and verify that they reflect the actual status of the components. The WWN bezel covers the WWN cards and allows its LEDs to shine through. The LEDs on the WWN bezel provide a consolidated view of the port, CP, and CR blade status.

Refer to the following table for a description of the WWN card LED patterns and the recommended actions for those patterns.

Table 17: WWN LED patterns for Brocade DCX 8510-8

LED location/purpose	Color	Status	Recommended action
Port blade/CP/CR blade power	Steady green	Power is okay.	No action required.
Port blade/CP/CR blade status	Steady amber	Card is faulty.	Check card.
	No light (LED is off)	Card is okay.	No action required.
NOTE: If a blade slot has a filler panel installed, the corresponding LEDs on the WWN card do not light up.			
NOTE: If a status LED on the WWN bezel flashes, the power LED on the WWN bezel also flashes, for increased visibility.			

The following figure displays the WWN bezel (logo plate). The WWN cards are under the bezel.

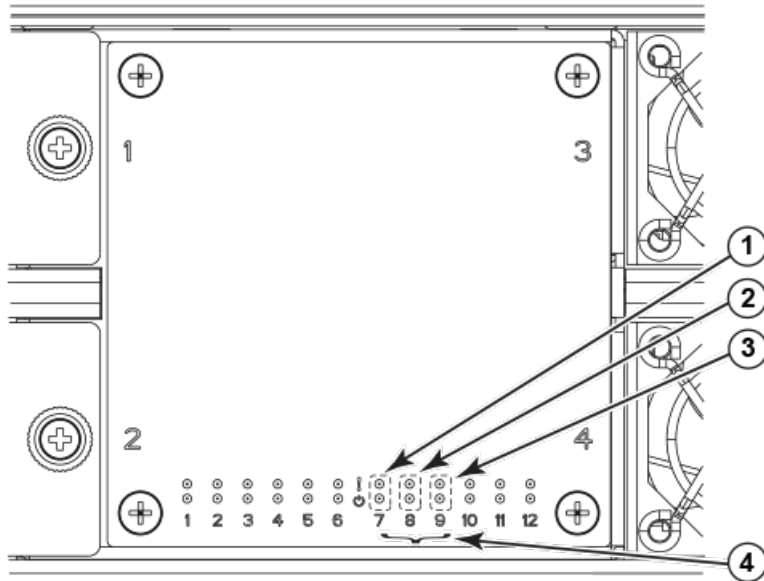
Figure 38: WWN bezel (logo plate) with LEDs on Brocade DCX 8510-8

1. CP blade Status (above) and Power (below) LEDs
2. CR blade Status (above) and Power (below) LEDs
3. Port blade Status (above) and Power (below) LEDs
4. Slot numbers

Managing Cables

Cables can be organized and managed in a variety of ways, for example, using cable channels on the port sides of the cabinet or patch panels to minimize cable management.

With the vertical orientation of the blades in the Brocade DCX 8510-8, a cable management comb is provided below the blades on the port side.

Following is a list of recommendations:

- Leave at least 1 m (3.28 ft) of slack for each port cable. This provides room to remove and replace the device, allows for inadvertent movement of the rack, and helps prevent the cables from being bent to less than the minimum bend radius.
- The minimum bend radius should be no smaller than ten times the cable radius. The minimum radius to which a 50 micron cable can be bent under full tensile load is 5.1 cm (2 in.). For a cable under no tensile load, that minimum is 3.0 cm (1.2 in.).
- If ISL Trunking is in use, group the cables by trunking group. The ports are color-coded to indicate which ports can be used in the same ISL Trunking group: eight ports marked with solid black ovals alternate with eight ports marked with oval outlines.
- Generally, Velcro[®] type cable restraints are recommended to avoid creating sharp bends in the cables. Do not use tie wraps with optical cables because they are easily overtightened and can damage the optic fibers.
- For easier maintenance, label the fiber-optic cables and record the devices to which they are connected.
- Do not route cables in front of the air exhaust vents.
- Route the cables to the bottom of the Brocade DCX 8510-8 through the cable management comb.
- Keep LEDs visible by routing port cables and other cables away from the LEDs.

NOTE

Refer to "Cabling Best Practices" (available at <http://www.brocade.com>) for cable management guidelines.

For the procedure to install the ICL cables, refer to "[Inter-chassis link \(QSFP\) cable removal and replacement.](#)"

Removal and Replacement Procedures

Introduction

NOTE

Read the safety notices before servicing ([Caution and Danger Notices](#)).

The field-replaceable units (FRUs) in the device can be removed and replaced without special tools. The device can continue operating during many of the FRU replacements if the conditions specified in the procedures are followed.

The following sections contain FRU removal and replacement procedures (RRPs).

ESD precautions

The device contains ESD-sensitive FRUs. When working with any device FRU, use correct electrostatic discharge (ESD) procedures.

- Wear a wrist grounding strap connected to chassis ground (if the device is plugged in) or a bench ground.



DANGER

For safety reasons, the ESD wrist strap should contain a series 1 megaohm resistor.

- Store all ESD-sensitive components in antistatic packaging.



CAUTION

Static electricity can damage the chassis and other electronic devices. To avoid damage, keep static-sensitive devices in their static-protective packages until you are ready to install them.

Chassis door removal and replacement

NOTE

The chassis door must be installed to ensure that the device meets EMI and other regulatory certifications.

Time and items required

The replacement procedure for the chassis door takes less than five minutes.

Removing a chassis door

Support the door to prevent it from falling. Pull and remove the door. It will pop off the ball studs.

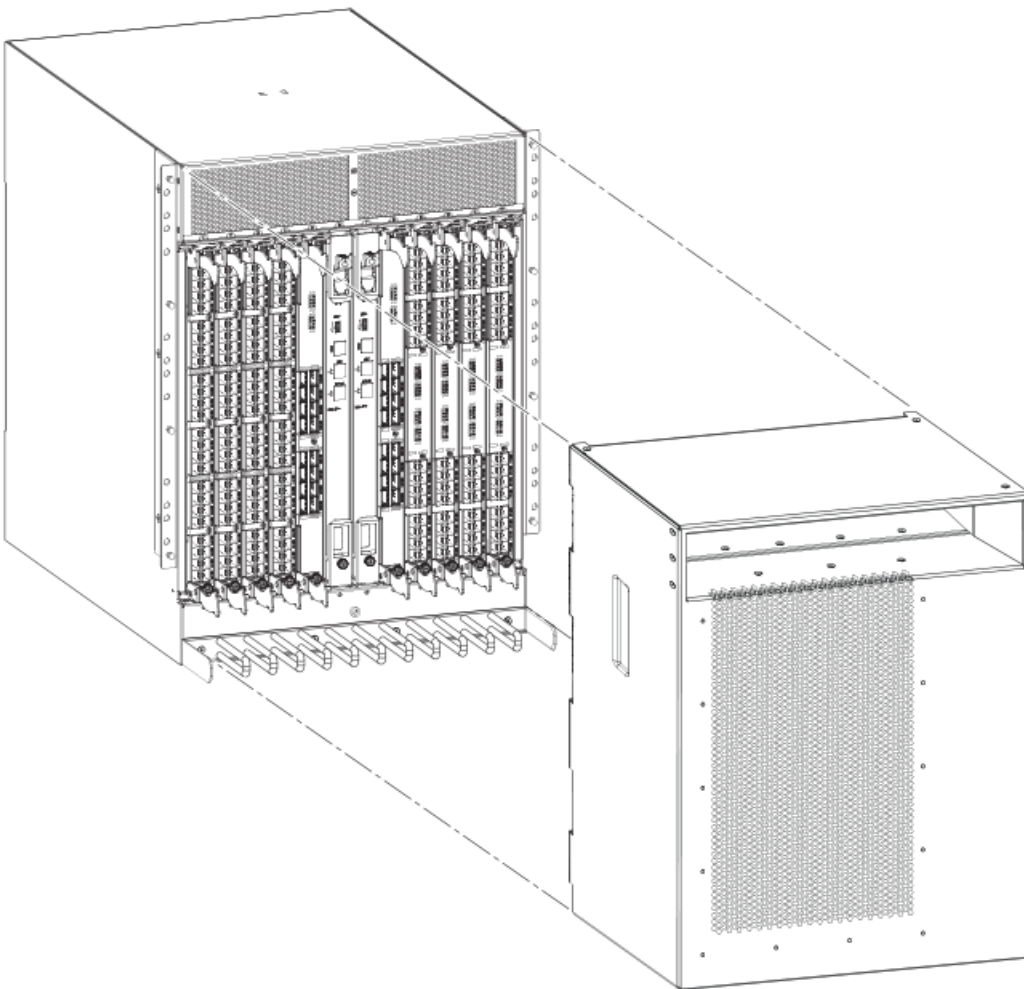
Figure 39: Removal and replacement of the chassis door

Replacing a chassis door

Complete the following steps to reinstall the door.

1. Align the holes in the door with the ball studs on the chassis.
2. Push the door into place. It will snap onto the studs.

Cable management comb removal and replacement

The Brocade DCX 8510-8 can continue to operate during the replacement of the cable management comb.

Time and items required

The replacement procedure for the cable management comb takes less than five minutes. A #1 Phillips screwdriver is required.

Removing a cable management comb

Complete the following steps to remove the cable management comb.

1. Remove the chassis door.
2. Remove the cables from the cable management comb and rearrange the cables around the comb.
3. Unscrew and save the four (4) screws holding the comb to the chassis. Support the comb to prevent it from falling.
4. Remove the cable management comb.

Figure 40: Removal and replacement of the cable management comb

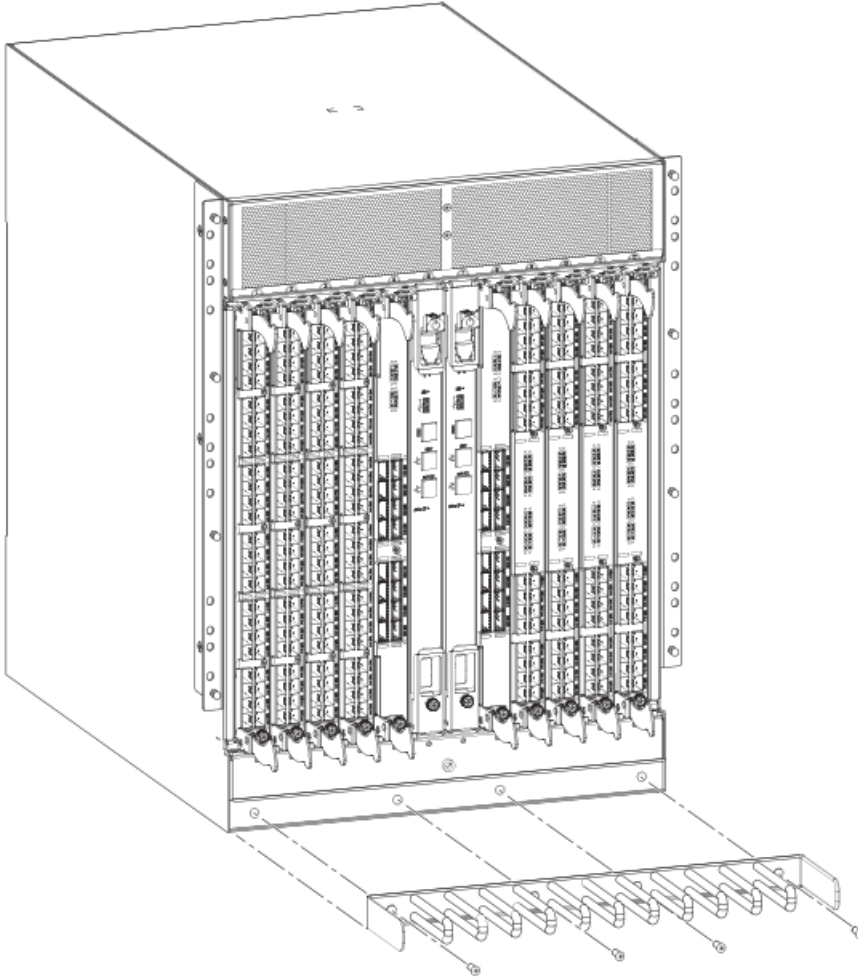

Replacing a cable management comb

Complete the following steps to replace the cable management comb.

1. Position and tighten the four (4) screws to secure the cable management comb to the chassis.
2. Arrange the cables along the cable management comb.
3. Replace the chassis door.

Port and application blade removal and replacement

This section describes how to remove and replace port and application blades. It does not cover the core (CR) blades or the control processor (CP) blades.



CAUTION

If you do not install a module or a power supply in a slot, you must keep the slot filler panel in place. If you run the chassis with an uncovered slot, the system will overheat.

Slots are numbered from 1 through 12, from left to right when facing the port side of the Brocade DCX 8510-8. Port and application blades can be installed in slots 1 through 4 and 9 through 12.

This section is applicable for all the following port and application blades supported on the chassis:

Blade	DCX 8510-4	DCX 8510-8
FS8-18 port blade	Supported	Supported
FC8-32E port blade	Supported	Supported
FC8-48 port blade	Supported	Supported
FC8-64 port blade	Supported	Supported
FC16-32 port blade	Supported	Supported
FC16-48 port blade	Supported	Supported
FC16-64 port blade	Supported	Supported
FCOE10-24 application blade	Not supported	Supported only on slot 1
FX8-24 extension blade	Supported	Supported

NOTE

The FCOE10-24 blade is not supported in the same chassis with FC8-64, FC16-48, FC16-64, or FX8-24 blades. For complete list of limitations on the FCOE10-24 application blade, refer to the *Fabric OS Release Notes*.

Time and items required

The replacement procedure for each blade takes less than 10 minutes. Removing and restoring transceivers and cables may take longer depending on how many must be changed. The following items are required for the blade and filler panel replacement:

- Electrostatic discharge (ESD) grounding strap
- Workstation computer
- Replacement blade or filler panel
- #2 Phillips screwdriver
- Small form-factor pluggable (SFP+, mSFP, or QSFP) transceivers (as needed)
- Optical and copper cables (as needed)

NOTE

For information about the transceivers that are qualified for the Brocade chassis, refer to the Tranceiver Removal and Replacement section.

Removing a blade

Complete the following steps to remove a blade.

Follow electrostatic discharge (ESD) precautions when removing a blade. Wear a wrist grounding strap connected to chassis ground (if the device is plugged in) or a bench ground.

**DANGER**

For safety reasons, the ESD wrist strap should contain a series 1 megaohm resistor.

NOTE

Before removing any cables from a blade, note the cable order (identify each cable by its physical port). It is a good practice to keep a table of cable to port mapping.

NOTE

If multiple blades are being replaced, replace one blade at a time.

This procedure is applicable for all the port and application blades supported on the device.

1. Remove the chassis door.
2. Check the power LED, status LED, and port status LED to identify any possible problems. A failed port or application blade can be identified by inspecting the LEDs on the front panel of each blade.
3. Establish a Telnet or console session.
Before replacing a blade, establish a Telnet or console connection to determine a failure and verify operation after replacement. Use the `switchShow` command to view the status of the blades.
4. Check for adequate cable slack. Ensure there is plenty of cable slack to remove a blade without cable obstruction.
5. Ensure that the part number on the unit being replaced matches the replacement part number. The `chassisShow` command displays information about the blades, including part numbers (`xx-xxxxxxx-xx`), serial numbers, and additional status.
6. Ensure that traffic is not flowing through the blade (port status LED should be off) prior to disconnecting cables.
7. Ensure that traffic is not flowing through the blade.
8. Disconnect all cables and transceivers from the blade. For mSFP transceivers (FC8-64 only), it is recommended that you use the pull tab to remove the transceiver from the blade.
9. If removing an FX8-24 extension blade, perform the following steps:
 - a) Delete all `fciptunnel` configurations via the `portcfg fciptunnel slot / vePort` command.
 - b) Delete all IP Routes defined on the blade to be removed via the `portcfg iproute` command.
 - c) Delete all IP interfaces (IPIFs) defined on the blade via the `portcfg ipif slot/geX | xgeX` command.
 - d) If logical switches are used on the switch, move all FX8-24 ports back to the default logical switch.

NOTE

If you are removing the FX8-24 blade to install in a different slot, you must remove configuration using the preceding steps, then reconfigure the blade in the new slot. If you move the blade without performing these steps and the blade faults, you must move the blade to the original slot and remove configuration.

10. Unscrew the two thumbscrews from the ejectors on the blade using the Phillips screwdriver. Unscrew the top thumbscrew until it pops out. This initiates a hot-swap request.
11. Wait for the power LED to turn off in response to the hot-swap request before removing the blade.
12. Open the ejectors by rotating them toward the center of the blade face. Pull the blade out of the chassis using the ejectors.
13. If the blade is not being replaced by another blade, install a filler panel.

Figure 41: Removal and replacement of the port and application blades (FC16-48 port blade shown)

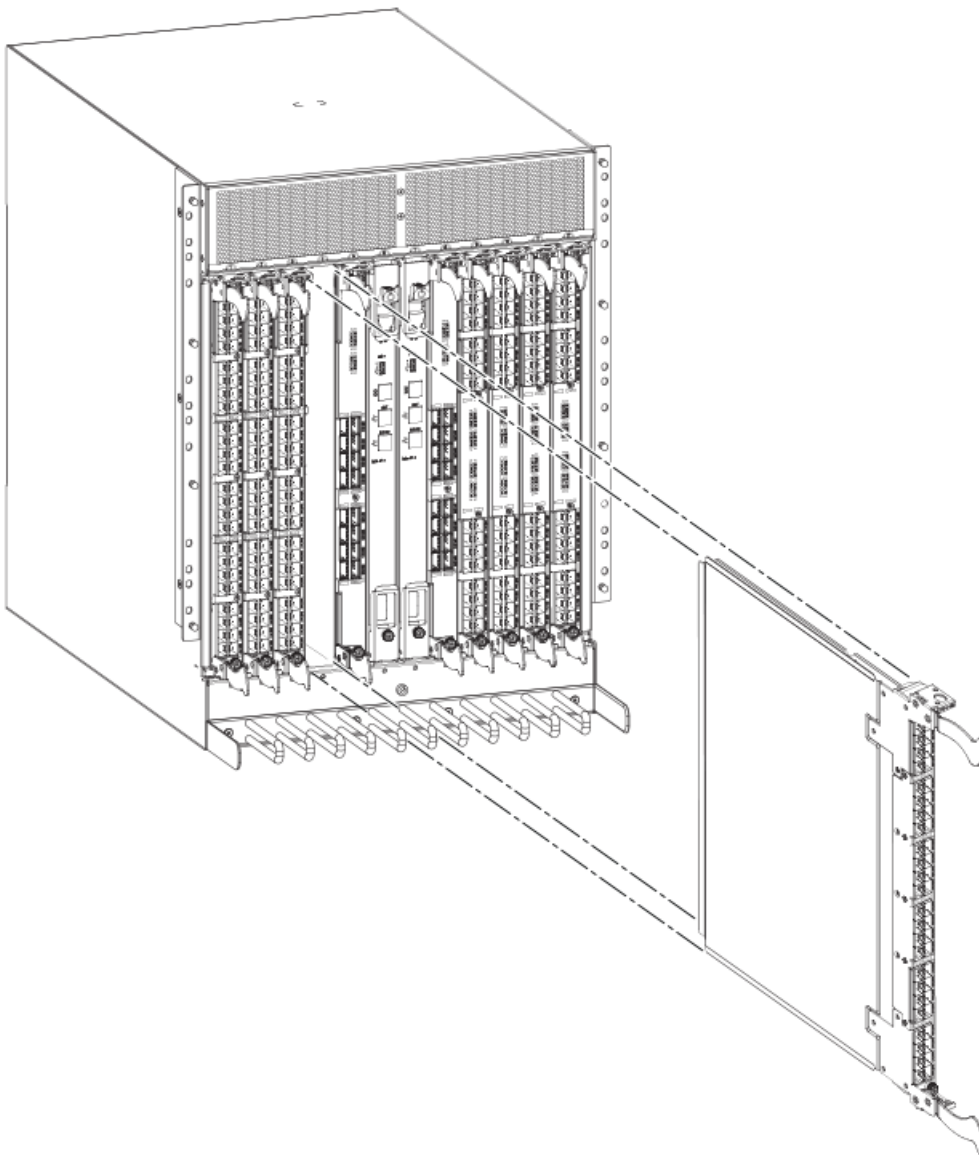

Replacing a blade

Complete this procedure to replace a blade.

Follow electrostatic discharge (ESD) precautions when replacing a blade. Wear a wrist grounding strap connected to chassis ground (if the device is plugged in) or a bench ground.

**DANGER**

For safety reasons, the ESD wrist strap should contain a series 1 megaohm resistor.

1. Orient the blade so that the ports are at the front of the chassis and the flat side of the blade is on the left.
2. Open the ejectors by rotating them toward the center of the blade face, align the flat side of the blade inside the top and bottom rail guides in the slot, and slide the blade into the slot until it is firmly seated.
3. Close the ejectors by rotating them away from the center of the blade. The levering action of the ejectors seats the blade in the slot.
4. Tighten the thumbscrews using the Phillips screwdriver.
5. Verify that the power LED on the port blade is displaying a steady green light. If it does not turn on, ensure that the blade is firmly seated.
6. Verify that the Status LED on the blade shows amber until POST completes for the blade. The status LED should then display green. If the LED remains amber, the board may not be properly seated in the backplane or the board may be faulty.
7. Install the transceivers and cables in the blade. For mSFP (**FC8-64** port blade only) and QSFP (**FC16-64** port blade only) transceivers, it is recommended that you install the cables in the transceivers before installing the transceivers in the blade.
8. Group and route the cables through the cable management comb.
9. Replace the chassis door.

Blade filler panel removal and replacement

This section describes how to remove and replace blade filler panels.

NOTE

Some filler panels have two thumbscrews and some have only one. Be sure to unscrew or tighten both if you are using the two-screw version.

Blade filler panel removal and replacement

This section describes how to remove and replace blade filler panels.

NOTE

Some filler panels have two thumbscrews and some have only one. Be sure to unscrew or tighten both if you are using the two-screw version.

Removing a filler panel

Complete the following steps to remove a filler panel from the chassis.

**CAUTION**

If you do not install a module or a power supply in a slot, you must keep the slot filler panel in place. If you run the chassis with an uncovered slot, the system will overheat.

1. Remove the chassis door.
2. Unscrew the thumbscrews on the panel using the Phillips screwdriver.
3. Using the tabs, pull the filler panel out of the chassis.

Figure 42: Removal and replacement of the blade filler panel

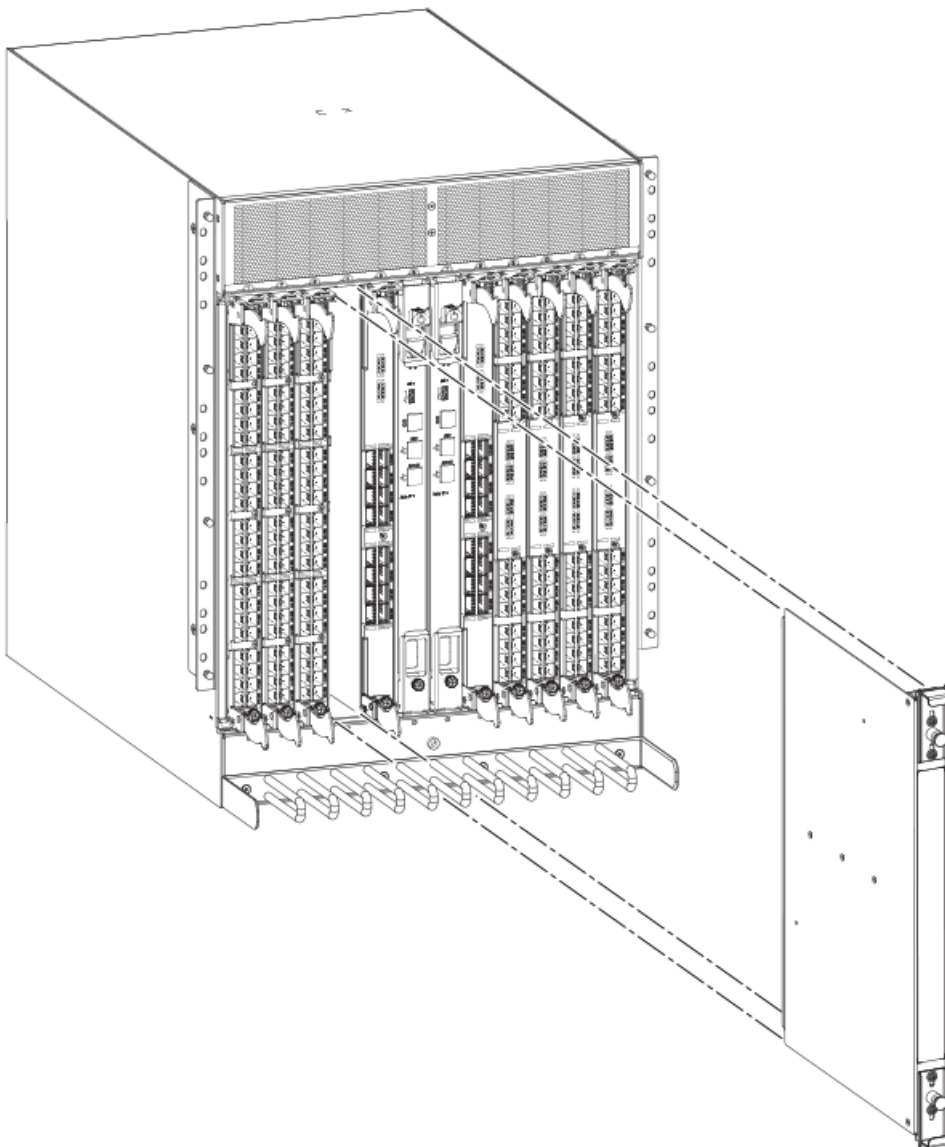

Replacing a filler panel

Do not leave a slot empty. This will adversely affect cooling of the chassis.

1. Orient the filler panel.
2. Slide the filler panel into the slot until it is firmly seated.
3. Tighten the thumbscrews.
4. Replace the chassis door.

Control processor blade (CP8) removal and replacement

This document describes how to remove and replace a control processor (CP8) blade.

Each chassis has two CP8 blades. They are located in slots 6 and 7.

NOTE

The CP8 blade is compatible only with the Brocade DCX Backbones (including the DCX 8510 Backbones).

NOTE

The firmware upgrade policy for CP8 blades specifies testing for the current Fabric OS release and one version earlier. It is possible to upgrade by more than one version, but it is a very specific and detailed process. Read the directions under [Downloading firmware from an FTP server](#) or [Downloading firmware from a USB device](#) carefully.

NOTE

If the new CP blade does not have the same firmware as the active CP blade, the new blade must be upgraded to the same firmware version. You can determine the firmware version on the replacement blade and perform a firmware upgrade if necessary after inserting the blade in the chassis, but you must disable high availability (HA) before inserting the new blade. If the new CP blade is severely down-level, a very specific procedure must be followed to bring the blade up to the correct firmware version.

Time and items required

The replacement procedure for the CP blade takes approximately 30 minutes. The following items are required for the CP blade replacement:

- Electrostatic discharge (ESD) grounding strap
- Workstation computer
- Serial cable
- IP address of an FTP server for backing up the device configuration
- #2 Phillips screwdriver
- Replacement CP blade

Faulty CP blade indicators

Confirm that you need to replace the CP blade. The following events may indicate that a CP blade is faulty:

- The status LED on the CP blade is lit steady amber, or the power LED is not lit.
- The CP blade does not respond to Telnet commands, or the serial console is not available.
- The `slotShow` command does not show that the CP blade is enabled.
- The `haShow` command indicates an error.
- The clock is inaccurate, or the CP blade does not boot up or shut down normally.
- Any of the following messages display in the error log:

- "Slot unknown" message relating to a CP slot
- CP blade errors or I2C timeouts
- FRU: FRU_FAULTY messages for a CP blade
- Configuration loader messages or "Sys PCI config" messages
- Generic system driver messages ("FABSYS")
- Platform system driver messages ("Platform")
- EM messages that indicate a problem with a CP blade
- Function fail messages for the CP master

For more information about error messages, refer to the *Brocade Fabric OS Message Reference*.

Recording critical device information

Back up the backbone configuration before you replace a CP blade. Refer to the *Brocade Fabric OS Administration Guide* for backup information.

NOTE

The following instructions reference specific slot numbers as examples. These numbers will be different on a chassis with slots for four port blades and a chassis with slots for eight port blades. These numbers will be different between the DCX 8510-8/DCX and the DCX 8510-4/DCX-4S chassis.

1. Connect to the chassis and log in as `admin`, using a serial console connection.
2. Enter `haShow` to determine which CP blade is active. The following example is from an 8-slot chassis.

```
DCX_124:admin> haShow
Local CP (Slot 7, CP1) : Active
Remote CP (Slot 6, CP0) : Standby, Healthy
HA Enabled, Heartbeat Up, HA State Synchronized
```

3. Enter all remaining commands from the serial console for the active CP blade, unless otherwise indicated. For more information about commands, refer to the *Brocade Fabric OS Command Reference*.
4. If the active CP blade is faulted, automatic fail over to the standby CP blade should have occurred. Confirm that the standby CP blade is active and power off the faulted CP blade, log in to the standby CP blade, and skip to step 7.

If automatic fail over has not occurred, manually fail over the faulty blade by moving the slider to the off position (to the bottom). Then power off the faulted blade, log in to the standby CP blade, and skip to step 7.
5. If both CP blades are healthy and you want to replace the standby CP blade, log in to the active CP blade and skip to step 7.
6. If both CP blades are healthy and you want to replace the active CP blade, log in to the active CP blade and run the following steps:
 - a) Run the `haFailover` command to make the standby CP blade the active blade. The currently active CP blade becomes the standby blade. Wait until the status LED on the currently active CP blade is no longer lit.
 - b) Confirm the completion of the failover by running the `haShow` command.
 - c) Log in to the new active CP blade.
7. Run `firmwareShow` to note the firmware version of the active CP blade.

The following example shows the results of the `firmwareshow` command when the firmware versions on the two CP blades are not the same. Note the warning message at the end of the output.

```
DCX_120:root> firmwareshow
```

Slot Name	Appl	Primary/Secondary Versions	Status
06 CP0	FOS	v7.1.0a v7.1.0a	STANDBY
07 CP1	FOS	v7.3.0b v7.3.0b	ACTIVE *

WARNING: The local CP and remote CP have different versions of firmware, please retry `firmwaredownload` command.
DCX_120:root>

8. Run `haDisable` from the active CP blade to prevent failover or communication between the CP blades during the replacement.
9. Enter the `configupload -vf` command. This command uploads the backbone virtual fabric data.
10. Enter the `configupload -all` command. This command uploads the chassis and switch configuration for all logical switches.
11. In a FICON environment, log in as root and enter `configupload --map` to upload port-to-area mapping information. With Fabric OS 7.4.0, you need to upload the configuration with `-map` option in a FICON-enabled DCX 8510 chassis if port-bound addressing is used.

Power-up procedure

Use the procedures in this section to remove and replace a single control processor (CP) blade while chassis power is on. To replace both CP blades, refer to the power-down replacement procedures.

Removing a control processor blade (CP8)

The chassis continues to operate while a CP blade is being replaced if the redundant CP blade is active and a failover does not occur. You can prevent failover by entering the `haDisable` command.

Complete the following steps to remove a CP8 control blade.

1. Remove the chassis door.
2. Log in to the active CP as the admin user. You can use a serial cable or Telnet, Web Tools, or Fabric Manager. Determine which CP is active using the `haShow` command or view the active LED on the front of the CP.
3. If the faulty CP is the active CP, issue the `haFailover` command. Wait until the failover has completed. Use the `haShow` command to verify the CPs are synchronized and the failover is complete.

Depending on the nature of the CP failure, it is possible that the `haFailover` command may not work. Proceed to the next step anyway.

4. Enter the `haDisable` command. This is required before physically removing and replacing a CP blade.
5. Power off the blade by sliding the slider switch in the top ejector down to the off position. Do not eject the blade until the power LED is off and you have completed the next two steps.
6. Disconnect all cables from the faulty (standby) CP.
7. Unscrew the thumbscrew from both ejectors using the Phillips screwdriver.
8. Lever open both ejector handles simultaneously to approximately 45 degrees and pull the CP blade out of the chassis.

Figure 43: Removal and replacement of the control processor blade (CP8)

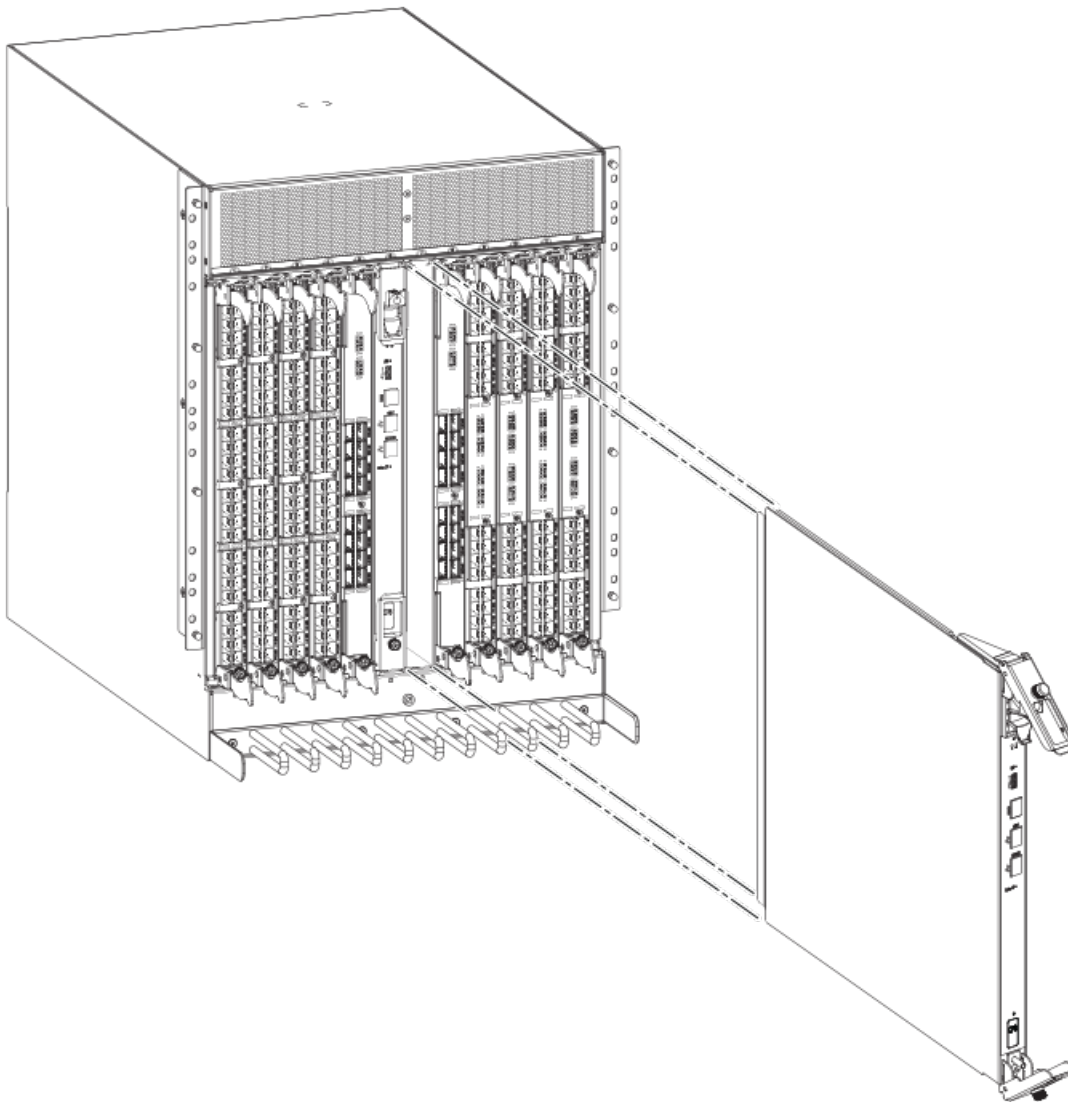

Replacing a control processor blade (CP8)

NOTE

Read all of the instructions for replacing the CP blade before beginning the procedure. Use the same version of Fabric OS on both CP blades. Using different versions is not supported and may cause malfunctioning. If the replacement CP blade has a different version of Fabric OS, bring both blades to the same firmware version.

Once you have installed the replacement CP blade, determine the version of firmware on the replacement CP blade and upgrade it if necessary.

Complete the following steps to remove a CP8 control blade.

1. Open the ejector handles to approximately 45 degrees. Orient the CP blade so that the handles are toward you and the flat metal side is on your left.
2. Align the flat metal side of the CP blade inside the lower and upper blade guides in the slot. Slide the CP blade into the slot until it is firmly seated.
3. Tighten the thumbscrew inside each handle using the Phillips screwdriver.
4. Turn the CP blade on by sliding the ON/OFF switch in the top handle up, to cover the thumbscrew.
5. Verify that the power LED is green. If not, ensure that the CP blade has power and is firmly seated and that the ejectors are in the locked position.
6. Connect the cables to the new CP blade.
7. Remain logged in to the active CP and continue to [Verifying operation of the new CP blade](#).

Power-down procedure

Use the following procedure to power down the chassis and replace both CP blades. You can replace a single CP blade using the power-up procedures.

1. Remove the chassis door.
2. If you haven't already done so, enter `configupload - all`, specifying a file name for saving configuration data. This saves all system configuration data including chassis and switch configuration for all logical switches to the file name specified. For more information, refer to the *Brocade Fabric OS Command Reference*.
3. If you haven't already done so, enter `configupload -vf`, specifying a file name for saving configuration data. This saves the backbone virtual fabric data to the file name specified. For more information, refer to the *Brocade Fabric OS Command Reference*.
4. If you haven't already done so, enter `configupload -map`, specifying a folder name. This command saves the port-to-area addressing mode configuration files to the folder specified. With Fabric OS 7.4.0, you need to upload the configuration with `-map` option in a FICON-enabled DCX 8510 chassis if port-bound addressing is used. For more information, refer to the *Brocade Fabric OS Command Reference*.

5. Power down the chassis.
6. Remove CP blades using the following steps:
 - a) Disconnect all cables from the blades.
 - b) Unscrew the thumbscrew from both ejectors for a blade using the Phillips screwdriver.
 - c) Lever open both ejector handles simultaneously to approximately 45 degrees and pull the CP blade out of the chassis.
7. Replace the blades using the following steps:
 - a) Open the ejector handles to approximately 45 degrees. Orient the CP blade so that the handles are toward you.
 - b) Align the flat metal side of the CP blade inside the blade guides in the slot. Slide the CP blade into the slot until it is firmly seated.
 - c) Tighten the thumbscrew inside each handle using the Phillips screwdriver.
 - d) Turn the CP blade on by sliding the ON/OFF switch in the left handle to the left to cover the thumbscrew.
8. Power up the chassis.
9. Verify that each blade's power LED is green. If not, ensure that the CP blade has power and is firmly seated and that the ejectors are in the locked position.
10. Connect the cables to the new CP blade.
11. Enter `chassisDisable`.
12. Enter `configDownload -vf` to download backbone virtual fabric data to the local system.
The chassis reboots and partitions are restored.
13. Enter `chassisDisable`.
14. Enter `configDownload -map` to download port-to-area addressing mode configuration files to the local system.
15. Enter `chassisReboot -m`.
The system recovers.
16. Enter `chassisDisable`.
17. Enter `configDownload -all` to download system configuration data, including chassis and switch configuration for all logical switches, to the local system.
All the licenses, configurations, and FCIP tunnels are restored.
18. Enter `reboot`.
The chassis becomes fully functional with the new CP blades.

Verifying operation of the new CP blade

To verify that boot and POST are complete on the new CP blade and that the CP blade has achieved failover redundancy, perform the following steps.

1. Enter `slotShow`. The command output shows the new CP blade as "enabled."

If the standby CP is unresponsive, you can try unplugging the new CP blade, running `haDisable` on the active CP blade, and plugging the new CP blade back in. At that point, you can repeat step 1 to begin the verification process again.

2. Log into each CP blade and enter the `haShow` command to display the CP status. Verify the CP state, status, health, and that the HA state is synchronized. Remedy any issues before proceeding. For more information on `haShow` output, refer to the *Brocade Fabric OS Command Reference*.
3. Determine the version of installed CP blades by entering `firmwareShow`. If the serial console on the replacement CP blade is connected, issue the `firmwareShow` command there. More information is available through the console.

NOTE

The device requires Fabric OS 7.0.0 or later to be recognized. If the firmware on the replacement blade is earlier than 7.0.0 it must be brought up to the version on the active CP blade, which must be at least 7.0.0.

4. If the firmware versions for both CP blades are the same, skip to [Completing the replacement](#).

If the firmware version on the replacement blade does not match that on the active CP blade, a warning message appears with the results of the `firmwareshow` command. The results of the `firmwareshow` command may look similar to the following. Note the warning message at the end of the output.

```
DCX_xyz:admin> firmwareshow
Slot Name      Appl      Primary/Secondary Versions      Status
-----
 6 CP0         FOS       v7.1.1.0                          ACTIVE
              v7.1.1.0
 7 CP1         FOS       v7.3.0a                             STANDBY *
              v7.3.0a

* Local CP
WARNING: The local CP and remote CP have different versions
of firmware, please retry firmwaredownload command.
```

5. Bring the replacement blade firmware to the same firmware level as the active blade using one of the following procedures:

- Run the `firmwaresync` command on the active CP blade to copy all firmware from the active CP blade to the standby CP blade.

NOTE

Using this command requires that existing telnet, secure telnet or SSH sessions to the standby CP blade to be restarted.

- Run the `firmwareDownload -s` command on the replacement blade to bring it up to the proper level.

6. Perform one of the following tasks to download firmware:

- If you are using an FTP server to download the firmware, skip to the procedure for downloading firmware from an FTP server.
- If you are using a USB device to download the firmware, skip to the procedure for downloading firmware from a USB device. If the firmware on the standby CP blade is more than one level down from the level on the active CP blade, you must have formatted USB devices for each of the versions you will need to upgrade.

For details on supported upgrade paths and steps to upgrade through multiple versions of Fabric OS, refer to the *Fabric OS Release Notes*, and the *Brocade Fabric OS Upgrade Guide*

Downloading firmware from an FTP server

For this task, determine the correct sequence of upgrading firmware versions to reach your target version.

Complete the following steps to download the firmware from an FTP server.

1. Log in to the standby CP blade as `admin`. If you need to know the IP address of the standby blade, run `ipaddrshow`. You should remain logged in to the active CP blade in order to monitor it.
2. Run `firmwareDownload -s` to download the firmware to the standby CP blade. The `-s` option also disables the autoreboot, so you will have to manually issue a reboot after the download finishes to initiate **firmwarecommit**. Enter all requested information (use default values).
3. When the download process finishes, run `firmwareDownloadStatus` to verify that the firmware has been updated. The command displays a running account of the progress of the `firmwareDownload` command (if it is still running) until the command has completed. The final message is similar to the following and will appear with a date and time stamp.

NOTE

The slot number for the CP blade is different for a chassis with slots for four port blades and a chassis with slots for eight port blades. The slot number in the following example is for a chassis with slots for four port blades.

```
Slot 4 (CP0, active): Firmwaredownload command has completed successfully. Use firmwreshow to verify the
firmware versions.
```

4. On the standby CP blade (the blade for which you just changed the firmware level), run `reboot`. The reboot of the standby CP will initiate a `firmwarecommit` to the secondary partition and log you out.

```
DCX_124:admin> reboot
Broadcast message from root (ttyS0) Fri Jun 18 14:49:45 2010...
The system is going down for reboot NOW !!
INIT: Switching to runlevel: 6
INIT: Sending processes the TERM signal DCX_124:admin> HAMu Heartbeat down, stop FSS
Unmounting all f##exiting due to signal: 9, pending signals: 0x20000, 0x0
ilesystems.
Please stand by while rebooting the system...
Restarting system.
The system is coming up, please wait...
.
.
.
Fri Jun 18 14:53:13 2010: Doing firmwarecommit now.
Please wait ...
Fri Jun 18 14:55:27 2010: Firmware commit completes successfully.
Validating the filesystem ...
Fri Jun 18 22:36:05 2010: Doing firmwarecommit now.
Please wait ...
Fri Jun 18 22:36:48 2010: Firmware commit completes successfully.
2010/06/18-14:56:50, [SULB-1004], 908, SLOT 7 | CHASSIS, INFO, Brocade_DCX, Firmwarecommit has completed.
2010/06/18-14:56:50, [SULB-1036], 909, SLOT 7 | CHASSIS, INFO, Brocade_DCX, The new Version: Fabric OS
[version]
2010/06/18-14:56:50, [SULB-1002], 910, SLOT 7 | CHASSIS, INFO, Brocade_DCX, Firmwaredownload command has
completed successfully.
```

5. Log back in to the standby CP blade and run `firmwareDownloadStatus` on the standby CP blade to validate a successful commit. This may take 10 minutes.
6. If you are upgrading through several levels of the Fabric OS, repeat step 2 through step 5 as often as necessary based on the path outlined in the preceding table. Otherwise, proceed to step 7.
7. Log out of the standby CP blade and log in to the active CP blade.
8. Proceed to the procedures for verifying operation of the new CP blade.

Downloading firmware from a USB device

For this task, determine the correct sequence of upgrading firmware versions to reach your target version.

Complete the following steps to download the firmware from a USB device.

This section assumes that the new firmware has already been copied onto the USB device. The folder structure on the USB device must be as follows in order to allow the device to be enabled:

- `brocade>`
 - `config`
 - `firmware`
 - `firmwareKey`
 - `support`

The firmware folder contains the folder for the specific release you are installing.

1. Insert the USB device into the active CP blade.
2. Attach a serial cable from the PC to the active CP blade.
3. Log in to the active CP blade as `admin` if you are not still logged in and enter `usbStorage -e` to enable the USB device.
4. Remove the serial cable from the active CP blade and attach it to the standby CP blade and log in as `admin`.
5. Run `firmwareDownload -s` to download the firmware to the standby CP blade. The `-s` option also disables the autoreboot, so you will have to manually issue a reboot after the download finishes to initiate **firmwarecommit**. Enter all requested information (use default values).
6. When the download process finishes, run `firmwareDownloadStatus` to verify that the firmware has been updated. The command displays a running account of the progress of the `firmwareDownload` command until the command has completed. The final message is similar to the following and will appear with a date and time stamp.

NOTE

The slot number for the CP blade is different for a chassis with slots for four port blades and a chassis with slots for eight port blades. The slot number in the following example is for a chassis with slots for four port blades.

```
Slot 4 (CP0, active): Firmwaredownload command has completed successfully. Use firmwareshow to verify the
firmware versions.
```

7. Ensure that you are still logged in to the standby CP blade (the blade for which you just changed the firmware level) and type `reboot`. The reboot of the standby CP will initiate a `firmwarecommit` to the secondary partition and log you out.

```
DCX_124: admin> reboot
Broadcast message from root (ttyS0) Fri Jun 18 14:49:45 2010...
The system is going down for reboot NOW !!
```

```

INIT: Switching to runlevel: 6
INIT: Sending processes the TERM signal DCX_124:admin> HAMu Heartbeat down, stop FSS
Unmounting all ##exiting due to signal: 9, pending signals: 0x20000, 0x0
ileystems.
Please stand by while rebooting the system...
Restarting system.
The system is coming up, please wait...
.
.
.
Fri Jun 18 14:53:13 2010: Doing firmwarecommit now.
Please wait ...
Fri Jun 18 14:55:27 2010: Firmware commit completes successfully.
Validating the filesystem ...
Fri Jun 18 22:36:05 2010: Doing firmwarecommit now.
Please wait ...
Fri Jun 18 22:36:48 2010: Firmware commit completes successfully.
2010/06/18-14:56:50, [SULB-1004], 908, SLOT 7 | CHASSIS, INFO, Brocade_DCX, Firmwarecommit has completed.
2010/06/18-14:56:50, [SULB-1036], 909, SLOT 7 | CHASSIS, INFO, Brocade_DCX, The new Version: Fabric OS
v6.3.0c
2010/06/18-14:56:50, [SULB-1002], 910, SLOT 7 | CHASSIS, INFO, Brocade_DCX, Firmwaredownload command has
completed successfully.

```

NOTE

The time stamp on the co-CPU may not be in sync with the main CPU on the blade. This is not a cause for concern.

8. Log back in to the standby CP blade and enter `firmwareDownloadStatus` on the standby CP blade to validate a successful commit. This may take 10 minutes.
9. If you are upgrading through several levels of the Fabric OS, repeat step 5 through step 8 as often as necessary based on the path outlined in the preceding table. Otherwise, proceed to step 10.
10. Log out of the standby CP blade and log in to the active CP blade.
11. Proceed to the procedures to "Completing the replacement."

Downloading Firmware from FTP Server

For this task, determine the correct sequence of upgrading firmware versions to reach your target version.

Complete the following steps to download the firmware from an FTP server to the replacement blade.

1. Log on to the standby CP blade as `admin` . If you need to know the IP address of the standby blade, run `ipaddrshow` .
 You should remain logged on to the active CP blade in order to monitor it.
2. Run `firmwareDownload -s` to download the firmware to the replacement (standby) CP blade. The `-s` option also disables the autoreboot, so you will have to manually issue a reboot after the download finishes to initiate a `firmwarecommit` . Enter all requested information (use default values).
3. When the download process finishes, run `firmwareDownloadStatus` to verify that the firmware has been updated. The command displays a running account of the progress of the `firmwareDownload` command (if it is still running) until the command has completed. The final message is similar to the following and will appear with a date and time stamp.

Slot 1 (CP0, active): Firmwaredownload command has completed successfully. Use firmwareshow to verify the firmware versions.

4. On the standby CP blade (the blade for which you just changed the firmware level), run `reboot`. The reboot of the standby CP will initiate a `firmwarecommit` to the secondary partition and log you out.

```
Chassis_1:admin> reboot
Broadcast message from root (ttyS0) Fri Jun 17 14:49:45 2016...
The system is going down for reboot NOW !!
INIT: Switching to runlevel: 6
INIT: Sending processes the TERM signal Chassis_1:admin> HAMu Heartbeat down, stop FSS
Unmounting all filesystems.
Please stand by while rebooting the system...
Restarting system.
The system is coming up, please wait...
.
.
.
Fri Jun 17 14:53:13 2016: Doing firmwarecommit now.
Please wait ...
Fri Jun 17 14:55:27 2016: Firmware commit completes successfully.
Validating the filesystem ...
Fri Jun 17 22:36:05 2016: Doing firmwarecommit now.
Please wait ...
Fri Jun 17 22:36:48 2016: Firmware commit completes successfully.
2016/06/17-14:56:50, [SULB-1004], 908, SLOT 2 | CHASSIS, INFO, Brocade_X6, Firmwarecommit has completed.
2016/06/17-14:56:50, [SULB-1036], 909, SLOT 2 | CHASSIS, INFO, Brocade_X6, The new Version: Fabric OS
[version]
2016/06/17-14:56:50, [SULB-1002], 910, SLOT 2 | CHASSIS, INFO, Brocade_X6, Firmwaredownload command has
completed successfully.
```

5. Log back on to the standby CP blade and run `firmwareDownloadStatus` on the standby CP blade to validate a successful commit. This may take 10 minutes.
6. If you are upgrading through several levels of the Fabric OS, repeat step 2 through step 5 as often as necessary based on the path outlined in the preceding table. Otherwise, proceed to step 7.
7. Log out of the standby CP blade and log on to the active CP blade.
8. Proceed to the procedures for verifying operation of the new CP blade.

Downloading Firmware from USB Device

For this task, determine the correct sequence of upgrading firmware versions to reach your target version.

This section assumes that the new firmware has already been copied onto the USB device. The folder structure on the USB device must be as follows in order to allow enable the device:

- `brocade>`
 - `config`
 - `firmware` (Contains the specific release you are installing)
 - `firmwareKey`
 - `support`

Complete the following steps to download the firmware from a USB device to the replacement blade.

1. Insert the USB device into the active CP blade.
2. Attach a serial cable from the PC to the active CP blade.
3. Log on to the active CP blade as `admin` if you are not still logged on and enter `usbStorage -e` to enable the USB device.
4. Remove the serial cable from the active CP blade and attach it to the standby CP blade and log on as `admin`.
5. Run `firmwareDownload -s` to download the firmware to the standby CP blade. Enter all requested information. The `-s` option disables the autoreboot, so you need to manually issue a reboot after the download finishes to initiate a `firmwarecommit`. Use all default values, except for USB [Y]. (This ensures that USB is used for downloading.)
6. When the download process finishes, run `firmwareDownloadStatus` to verify that the firmware has been updated. The command displays a running account of the progress of the `firmwareDownload` command until the command has completed. The final message is similar to the following and will appear with a date and time stamp.

```
Slot 1 (CP0, active): Firmwaredownload command has completed successfully. Use firmwareshow to verify the
firmware versions.
```

7. Ensure that you are still logged on to the standby CP blade (the blade for which you just changed the firmware level) and type `reboot`. The reboot of the standby CP will initiate a `firmwarecommit` to the secondary partition and log you out.

```
Chassis_1: admin> reboot
Broadcast message from root (ttyS0) Fri Jun 17 14:49:45 2016...
The system is going down for reboot NOW !!
INIT: Switching to runlevel: 6
INIT: Sending processes the TERM signal Chassis_1:admin> HAMu Heartbeat down, stop FSS
Unmounting all ##exiting due to signal: 9, pending signals: 0x20000, 0x0
ilesystems.
Please stand by while rebooting the system...
Restarting system.
The system is coming up, please wait...
.
.
.
Fri Jun 17 14:53:13 2016: Doing firmwarecommit now.
Please wait ...
Fri Jun 17 14:55:27 2016: Firmware commit completes successfully.
Validating the filesystem ...
Fri Jun 17 22:36:05 2016: Doing firmwarecommit now.
Please wait ...
Fri Jun 17 22:36:48 2016: Firmware commit completes successfully.
2016/06/17-14:56:50, [SULB-1004], 908, SLOT 2 | CHASSIS, INFO, Brocade_X6, Firmwarecommit has completed.
2010/06/17-14:56:50, [SULB-1036], 909, SLOT 2 | CHASSIS, INFO, Brocade_X6, The new Version: Fabric OS
[version]
2010/06/17-14:56:50, [SULB-1002], 910, SLOT 2 | CHASSIS, INFO, Brocade_X6, Firmwaredownload command has
completed successfully.
```

NOTE

The time stamp on the co-CPU may not be in sync with the main CPU on the blade. This is not a cause for concern.

8. Log back on to the standby CP blade and enter `firmwareDownloadStatus` on the standby CP blade to validate a successful commit. This may take 10 minutes.
9. If you are upgrading through several levels of the Fabric OS, repeat step 5 through step 8 as often as necessary based on the path outlined in the preceding table. Otherwise, proceed to step 10.
10. Log out of the standby CP blade and log on to the active CP blade.
11. Proceed to the procedures to "Completing the replacement."

Completing the replacement

Complete the following steps to complete the CP blade replacement procedure.

1. Enter `haEnable` to re-enable HA on the active CP blade.

NOTE

The `haEnable` command will cause the standby CP blade to reboot. Wait until POST completes before moving to the next step. POST is complete when the Status LED on the CP blade returns to a steady green state.

2. Enter `haShow` and verify that the command output includes "HA Enabled, Heartbeat Up". If it is not yet enabled, re-enter the command until you have verified that redundancy is achieved.

NOTE

The `haEnable` command will cause the standby CP blade to reboot. The slot number for the CP blade is different for a chassis with slots for four port blades and a chassis with slots for eight port blades. The slot number in the following example is for a chassis with slots for eight port blades.

```
DCX_124:admin> hashow
Local CP (Slot 7, CP1) : Active
Remote CP (Slot 6, CP0) : Standby, Healthy
HA Enabled, Heartbeat Up, HA State Synchronized
```

3. Enter `firmwareShow` to verify that the firmware version has been updated and that the versions are the same on the two CP blades.

NOTE

The slot number for the CP blade is different for a chassis with slots for four port blades and a chassis with slots for eight port blades. The slot number in the following example is for a chassis with slots for four port blades.

```
DCX_8510:admin> firmwareshow
Slot Name   Appl   Primary/Secondary Versions  Status
-----
 2  FX8-24  FOS      v7.4.0
                v7.4.0
 4  CP0     FOS      v7.4.0          STANDBY
                v7.4.0
 5  CP1     FOS      v7.4.0          ACTIVE *
                v7.4.0
 7  FX8-24  FOS      v7.4.0
                v7.4.0
```

4. Pack the faulty CP blade in the packaging provided with the new CP blade, and contact the switch supplier to determine the return procedure.
5. Replace the chassis door.

If you have one or more application or extension blades in the chassis, the Fabric OS automatically detects mismatches between the active CP firmware and the blade's firmware and triggers the auto-leveling process. This auto-leveling process automatically updates the application blade firmware to match the active CP. At the end of the auto-leveling process, the active CP, application, and extension blades will run the same version of the firmware.

Core switch blade (CR16-x) removal and replacement

This section describes how to remove and replace a core switch blade (CR16-x). The device has two core switch blades:

- One CR16-8 blade in slot 5.
- One CR16-8 blade in slot 8.

Time and items required

The replacement procedure for the core switch blade takes approximately 30 minutes. The following items are required for the core switch blade replacement:

- Electrostatic discharge (ESD) grounding strap
- #2 Phillips screwdriver
- Replacement core switch blade

Faulty core switch blade indicators

Confirm that you need to replace the core switch blade before continuing. The following events may indicate that a core switch blade is faulty:

- The status LED on the core switch blade is lit steady amber, or the power LED is not lit.
- The `slotShow` command does not show that the core switch blade is enabled.
- The `haShow` command indicates an error.
- Any of the following messages display in the error log:
 - "Slot unknown" message relating to a core switch slot
 - Core switch blade errors or I2C timeouts
 - FRU: FRU_FAULTY messages for a core switch blade
 - Configuration loader messages or "Sys PCI config" messages
 - Generic system driver messages ("FABSYS")
 - Platform system driver messages ("Platform")
 - EM messages that indicate a problem with a core switch blade
 - Function fail messages for the core switch master

For more information about error messages, refer to the *Brocade Fabric OS Message Reference*.

Removing a core switch blade (CR16-x)

Follow electrostatic discharge (ESD) precautions when removing a blade. Wear a wrist grounding strap connected to chassis ground (if the device is plugged in) or a bench ground.



DANGER

For safety reasons, the ESD wrist strap should contain a series 1 megaohm resistor.

NOTE

The CR16-8 blade is compatible only with the Brocade DCX 8510-8.

NOTE

The device continues to operate while a core switch blade is being replaced.

Complete the following steps to remove the core switch blade.

1. Remove the chassis door.
2. Unscrew the two thumbscrews from the ejectors on the blade using the Phillips screwdriver. Unscrew the top thumbscrew until it pops out. This initiates a hot-swap request.
3. Label and then disconnect cables from the faulty core switch blade.
4. Open the ejectors by rotating them toward the center of the blade face. Pull the blade out of the chassis using the ejectors.

Figure 44: Removal and replacement of the core switch blade (CR16-8)

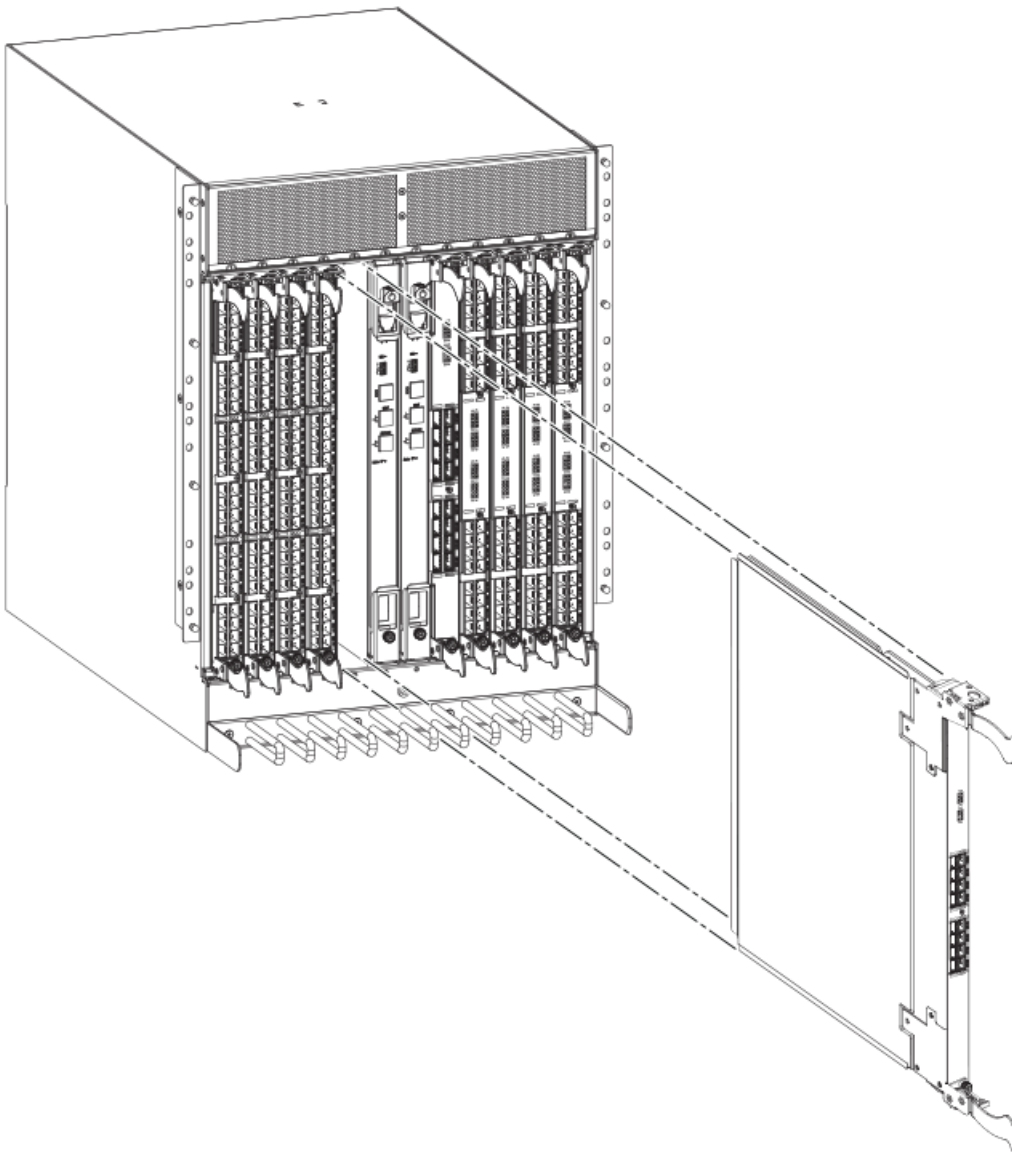

Replacing a core switch blade (CR16-x)

Follow electrostatic discharge (ESD) precautions when replacing a blade. Wear a wrist grounding strap connected to chassis ground (if the device is plugged in) or a bench ground.



DANGER

For safety reasons, the ESD wrist strap should contain a series 1 megaohm resistor.

NOTE

The CR16-8 blade is compatible only with the Brocade DCX 8510-8.

NOTE

The device continues to operate while a core switch blade is being replaced.

Complete the following steps to replace the core switch blade.

1. Open the ejectors by rotating them toward the center of the blade face. Orient the CR blade so that the handles are toward you.
2. Align the flat side of the blade inside the top and bottom rail guides in the slot with the components facing right, and slide the blade into the slot until it is firmly seated.
3. Close the ejectors by rotating them away from the center of the blade. The levering action of the ejectors seats the blade in the slot.
4. Power on the blade by screwing in the thumbscrews.
5. Verify that the power LED is green (might require a few seconds). If not, ensure that the core switch blade has power and is firmly seated and that the ejectors are in the locked position.
6. Verify that the status LED on the new blade is initially amber and will be until POST for the blade completes. This may take as long as several minutes. It then turns green.
7. Connect the cables to the new core switch blade. For the DCX 8510 models, if the QSFP cables are not used, make sure the rubber gaskets are in the QSFP transceivers.
8. Replace the chassis door.
9. Pack the faulty core switch blade in the packaging provided with the new core switch blade, and contact the device supplier to determine the return procedure.

Power supply removal and replacement

Use this procedure to remove and replace a power supply.

NOTE

Depending on the blade configuration of the chassis and the number of power supplies installed, the device may be able to continue operating during the replacement. Refer to the power supply specifications section in the *Brocade DCX 8510 Backbone Technical Specification* for this DCX device to determine your power requirements. If there is insufficient power, the chassis will start powering down blades until the power demand can be met. The device power supplies are 100-240 VAC, autosensing.

NOTE

A chassis with slots for eight port blades can have up to four power supplies installed. If you are adding additional power supplies, you can use the procedures in this section under "Replacing a power supply" to install the new power supplies. Be sure to follow steps on those procedures to enable sending notifications if the additional power supplies should fail.

Time and items required

The replacement procedure for each power supply takes less than five minutes. A power supply unit or filler panel is required for the power supply replacement.

Identifying power supplies

The following figure shows the location and identification of the power supplies.

Figure 45: Power supply identification

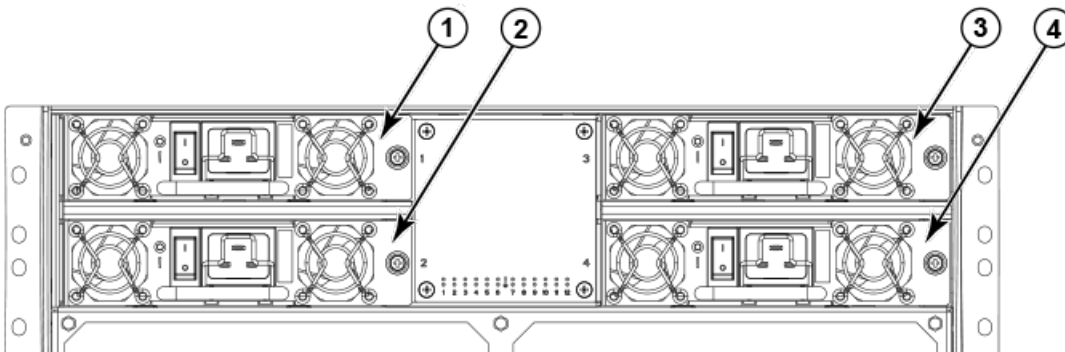

1. Power supply 1 (PS1)
2. Power supply 2 (PS2)
3. Power supply 3 (PS3)
4. Power supply 4 (PS4)

Removing a power supply

To remove a power supply, complete the following steps.

1. Perform the appropriate following action based on whether the device is operating:
 - If the device is not operating during the replacement procedure, go to step 2.
 - If the device is operating and will continue to operate during the replacement, check the power LEDs to verify that the minimum number of power supplies is functioning. Refer to [Providing power to the device](#) to check your power requirements.

2. Turn off the power switch.
3. Unlatch the power cord retainer clip.
4. Remove the power cord.
5. Loosen the thumbscrew.
6. Grasp the handle and pull, sliding the power supply from the chassis and supporting the power supply from beneath as you remove it.

Figure 46: Removal and replacement of the power supply

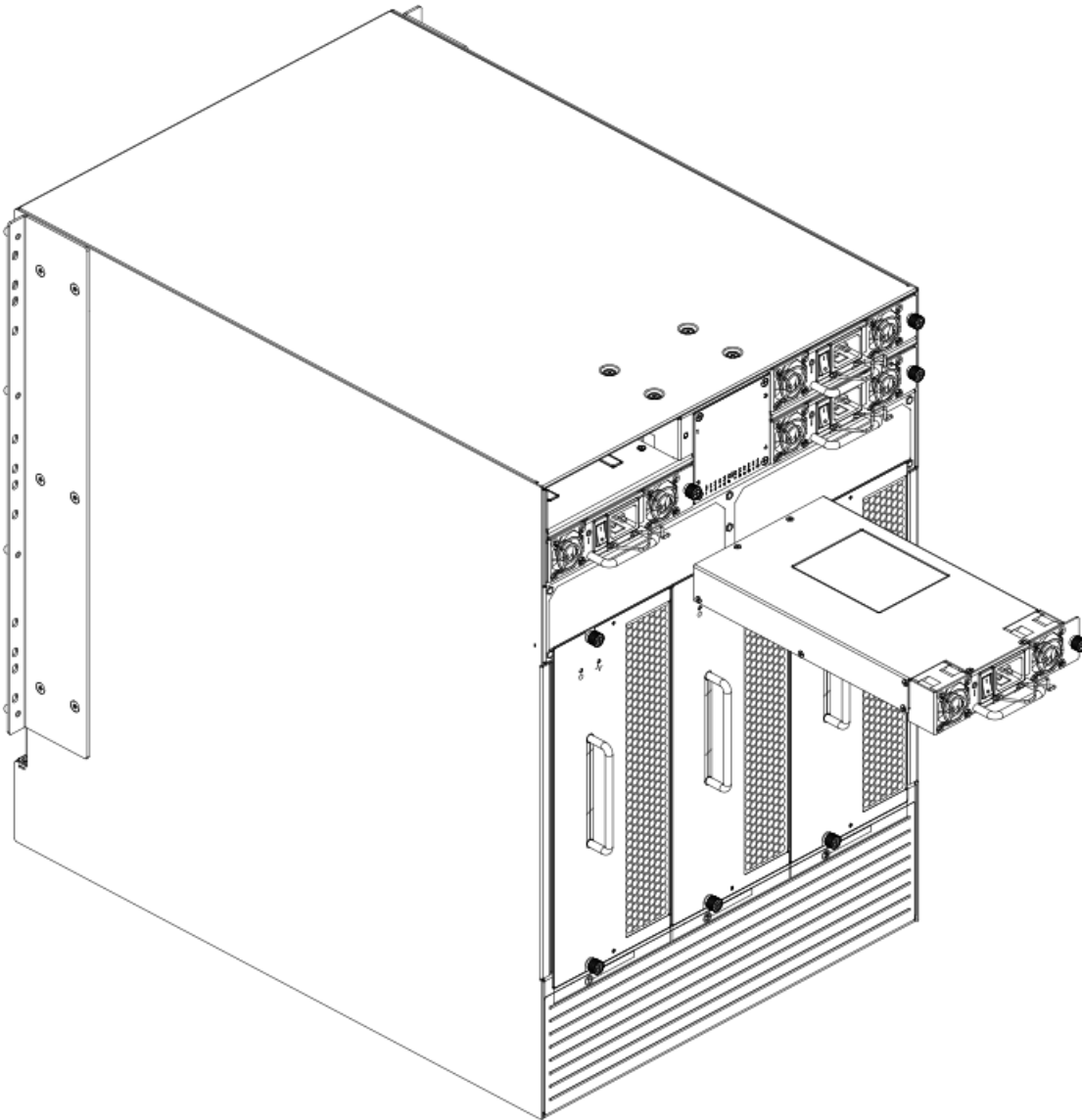

Replacing a power supply

To replace a power supply, complete the following steps.

1. If you are not replacing the power supply, insert a filler panel into the slot.
2. Otherwise, insert the power supply into the slot. Verify that the power supply is seated by gently pulling on the handle.
3. Tighten the thumbscrew.
4. Replace the power cord.
5. Latch the power cord retainer clip.
6. Turn on the power switch.
7. Verify that the power LED on the power supply displays a steady green light.
8. If you are installing two additional power supplies to bring the total power supplies up to four, perform one or both of the following tasks to enable sending notifications when one power supply fails.

NOTE

A maximum of four power supplies can be installed in the chassis.

- For Fabric Watch monitoring, change the switchStatus policy settings to the following:

```
switch.status.policy.PowerSupplies.down = 1
switch.status.policy.PowerSupplies.marginal = 0
```

For more details on executing the `switchStatusPolicyShow` and `switchStatusPolicySet` commands, refer to the *Fabric OS Command Reference*.

- For Monitoring and Alerting Policy Suite (MAPS) monitoring, follow procedures to update the active MAPS power supply switchstatus policy settings for four PSU devices in the "Additional MAPS features" section of the *Brocade Monitoring and Alerting Policy Suite Administrator's Guide*.

Blower assembly removal and replacement

Use this procedure to remove and replace a blower assembly.

NOTE

The device can continue operating during the replacement if other two blower assemblies are operating. To ensure continuous adequate cooling, maintain three operating blower assemblies at all times except for the brief period when replacing a blower assembly.

Time and items required

The replacement procedure for each blower assembly takes less than 5 minutes. The following items are required for the blower assembly replacement:

- Replacement blower assembly
- #2 Phillips screwdriver

Removing a blower assembly

Complete the following steps to remove a blower assembly from the chassis.

1. Before removing a blower assembly, verify that the other blower assemblies are functioning correctly. The power LEDs should be steady green.
2. Use the screwdriver to loosen the captive screws at the top and bottom of the blower assembly.
3. Grasp the handle and pull, sliding the blower assembly from the chassis and supporting the blower assembly from beneath as you remove it.

Figure 47: Removal and replacement of the blower assembly

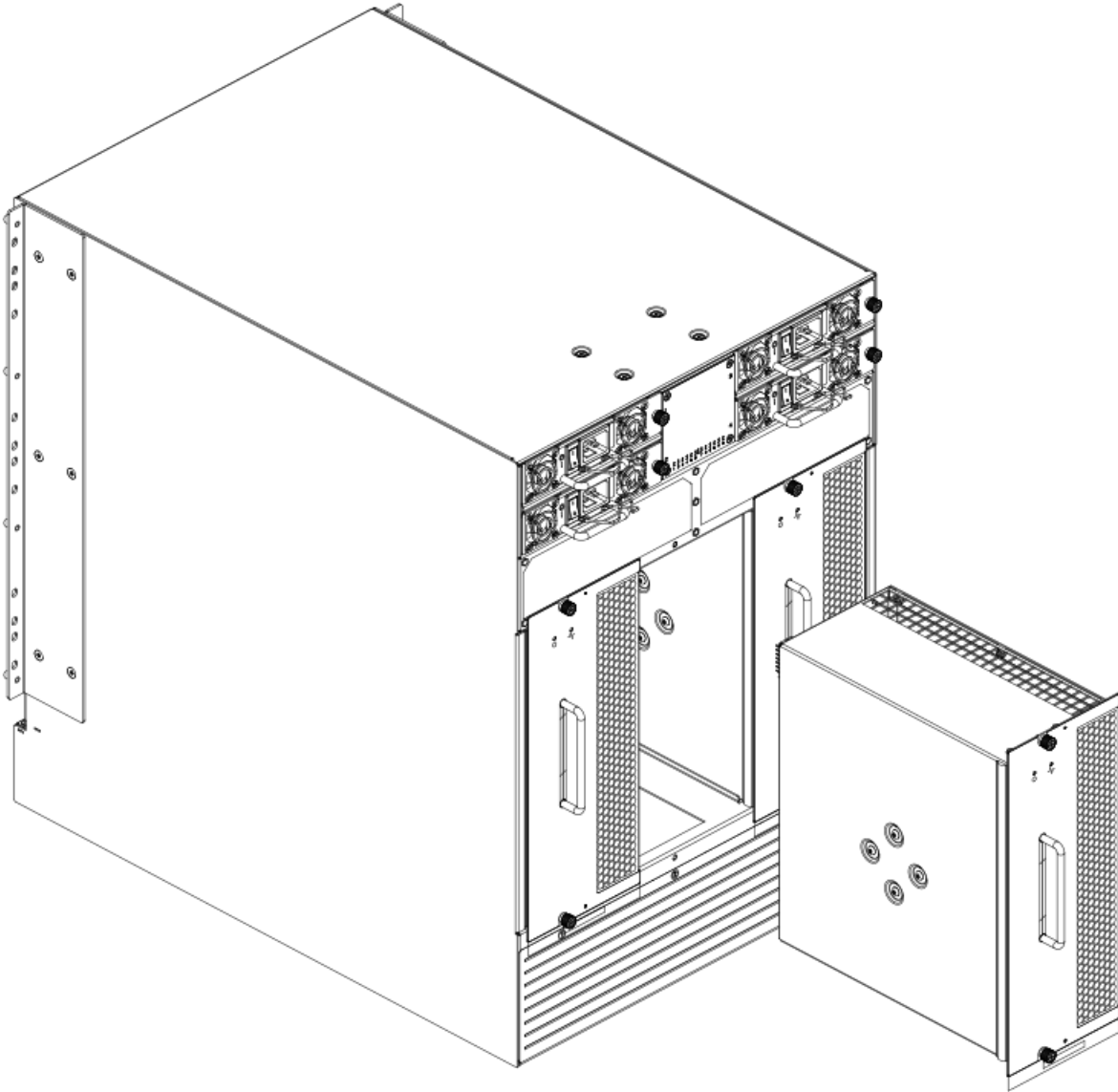

Replacing a blower assembly

Complete the following steps to replace the blower assembly in a chassis.

1. Orient the blower assembly and slide it into the chassis, pushing firmly to ensure that it is seated.
2. Verify that the power LED displays a green light.
3. Use the screwdriver or your fingers to tighten the captive screws.

WWN card removal and replacement

There are two WWN cards located beneath the WWN bezel (logo plate). As you are facing the bezel on the non-port-side of the chassis, WWN 1 is located on the left side, and WWN 2 is on the right. Before replacing cards, reference RASlog messages and use the WWN Recovery Tool (`wwnrecover`) as directed in the following sections to recover WWN cards. The tool will direct you to contact customer support if recovery fails. In these cases, Brocade Support will determine whether one or both WWN cards need replaced and will request the partner or OEM to send WWN cards from FRU inventory to the nearest Brocade Support office to be reprogrammed.

This section provides information on RASlog messages indicating WWN card problems, the WWN Recovery Tool, and complete steps to remove and replace WWN cards.

The following WWN card replacement procedures are available:

- Hot-swap procedure. Use this procedure when replacing one WWN card only. This procedure is non-disruptive as a system reboot is not required under most conditions.

NOTE

After replacing a WWN card using this procedure, RASlog messages EM-1220 or EM-1222 may indicate that a discrepancy or mismatch is detected between the WWN cards. You must monitor messages for errors and warnings, and then follow directions in messages to use `wwnrecover` for recovery. The `wwnrecover` tool may prompt you to reboot the control processors (CP) if the system is running with invalid IP addresses because the system was booted with a replacement card for WWN card 1.

- System power-down procedure. Use this procedure when replacing both WWN cards. This procedure disrupts system operations. Observe the following when replacing both WWN cards:
 - No additional reboot is required following card replacement after powering the system down.
 - If Brocade support has determined that both WWN cards need replaced, you must power-down the chassis, and then replace both WWN cards as a matched pair.
 - Be aware that if replacing both WWN cards, the IP addresses on the new WWN cards will be in effect when the chassis powers up. If these IP addresses are different from the previous cards, then you will not be able to establish ssh or other sessions that use the previous IP addresses. You can change IP addresses on the new cards using the `ipaddrset` command.

NOTE

If replacing the chassis, you do not need to remove WWN cards from chassis as they ship with replacement chassis.

Time and items required

If there is a need to replace one or both WWN cards, allow approximately 20 minutes. Refer to [Using `wwnrecover` 7.4](#) and [Verifying the need for replacement](#) before replacement.

The following items are needed to replace the WWN cards:

- Electrostatic discharge (ESD) grounding strap
- #2 Phillips screwdriver (required only for some versions of the WWN card)
- If a serial console session is used: serial cable and a workstation computer with a terminal emulator application (such as HyperTerminal for Windows systems or TIP for Solaris systems)

Using the wwnrecover utility

The `wwnrecover` utility permits a recovery of WWN card data in the event of corruption. Recovery is not possible if hardware issues prevent access to either WWN card or if the primary and backup copy of the license ID on either card is corrupted. This utility is not available in Fabric OS prior to v7.4.0.

Identical data must be maintained on each WWN card at all times so that if one card fails, the system can use the other card to provide valid system operation. To maintain data and ensure its integrity, the audits both WWN cards one hour after the first system boot-up, every 24 hours after boot-up, and any time a WWN card is inserted to compare the critical data.

If a data mismatch is detected during the audit, messages in the RASlog will provide a summary of all errors detected and prompt you through a data recovery process. The data recovery mechanism may vary depending on the error encountered and the data being compared. Problems such as a mismatch between license IDs cannot be fixed with `wwnrecover`, and the output will direct you to call Brocade Technical Support. For other problems, running `wwnrecover` can pinpoint the problem and, in some cases, permit you to fix it. Mismatched data can be resolved, and corrupt data can sometimes be recovered.

The following table lists RASlog messages that can occur during the WWN card audit routine.

Table 18: RASlog messages from WWN card audit

Error message	Issue
[EM-1220]...M1, ERROR ... A problem was found on one or both CID cards (x), please run the wwnrecover tool to get more information and recovery options.	Some kind of error or mismatch has been detected in the WWN card audit.
[EM-1221], ... M1, INFO, ... A WWN card has been inserted, a WWN verification audit will be run to detect any mismatches or other problems.	A second WWN card is enabled and the WWN card audit will be run. If an error is detected during the audit, EM-1220 and EM-1222 messages are generated.
[HIL-1650], CHASSIS, ERROR...Unable to detect WWN card in chassis. Access to WWN halted...	WWN card has been removed from the chassis. Replace as soon as possible since system is in degraded state.
[EM-1222], ... M1, WARNING, ... A WWN card access problem has been encountered, please run the wwnrecover tool to get more information and recovery options.	An error is detected during normal access to the WWN cards; typically, one of the cards is corrupted or inaccessible.
Recovery is not possible. Please contact Brocade Technical Support for replacement of the corrupted or inaccessible WWN(s).	The license ID on the two WWN cards do not match.

The `wwnrecover` utility must be used to maintain data integrity when replacing one or both WWN cards using instructions in the WWN card removal and replacement section. To run `wwnrecover`, log in as admin and enter the following command:

```
switch:admin# wwnrecover
```

For more information on `wwnrecover` and command syntax, refer to the *Brocade Fabric OS Command Reference*.

Verifying the need for replacement

Before replacing a WWN card, verify that the replacement is necessary. Any of the following events can indicate that the card requires replacement:

- Status LEDs on the WWN bezel not reflecting the actual status of the components.
- Power or Status LEDs on WWN card (beneath logo plate) indicate a problem.
- Problems viewing or modifying the data stored on the WWN card.
- Error messages regarding WWN units #1 or #2 from the `chassisshow` output.
- If an EM-1220 or EM-1222 error message occurs in the RASlog and WWN card recovery is not successful using `wnnrecover`.

NOTE

In the event of an EM-1220 or EM-1222 error message due to WWN card data corruption or data mis-matches across WWN cards, data recovery may be possible using the `wnnrecover` utility. For more information on using this utility, refer to [Using wnnrecover](#).

Preparing for WWN card replacement

If the WWN cards require replacement, complete the following steps. Follow electrostatic discharge (ESD) precautions.



DANGER

For safety reasons, the ESD wrist strap should contain a series 1 megaohm resistor.

1. Open a Telnet session to the chassis and log in to the active CP as admin. The default password is "password".
2. Verify that you are logged in to the active CP. Run the `haShow` command to determine the active CP.
3. Run the `supportSave` command on the active CP to capture all settings. These settings will be referenced to verify the settings have been correctly programmed after WWN replacement.
4. Contact Brocade Technical Support for replacement of WWN cards. Brocade Support will request the partner or OEM to send WWN cards from FRU inventory to the nearest Brocade Support office to be reprogrammed. Brocade Support will require the `Supportsave` data taken in the previous step so that the replacement cards can be reprogrammed prior to shipping to the partner or your site. If Brocade support has determined that both WWN cards need replaced, you must power-down the chassis, and then replace both WWN cards as a matched pair.

NOTE

Do not execute the `frureplace` command. The command will no longer be functional beginning with the release of Fabric OS 7.0.0c, but users with earlier versions of the Fabric OS should also *not* run the command.

Hot-swap replacement

You may replace one WWN card with the system powered on using the following steps to avoid interruption of system operation.

Use this procedure if Brocade Customer Support has determined that a WWN card needs replaced and you have received replacement cards. These procedures require use of the `wnnrecover` utility. For more information on this utility, refer to [Using wnnrecover](#).

You can use this procedure to replace one WWN card at a time while power is on. Follow all steps for one card, and then repeat the same steps to replace the other card. To replace both WWN cards simultaneously, use procedures under [Power-down replacement](#).

1. Remove the defective WWN card using procedures under [Removing the WWN card and WWN bezel \(logo plate\)](#) applicable to hot-swap replacement of WWN cards.

NOTE

Do not use steps in the WWN card and WWN bezel removal procedures to disable logical switches and power down the chassis.

Removing a WWN card will result in RASlog messages indicating that a WWN card cannot be detected. Since the system will be in a degraded state, install a WWN card as soon as possible.

2. Install the replacement WWN card into the empty slot.

When replacing cards, hold each card by the edges and insert the WWN cable onto the WWN module until the cables are fully seated.

3. Install the replacement WWN card into the empty slot.

When replacing cards, hold each card by the edges and slide the card into the chassis. Use the Phillips screwdriver and the screws to secure the WWN card to the chassis.

4. Verify that the WWN card is correctly connected by noting if the LEDs on the card reflects the status of the components.

5. Address any issues flagged by any RASlog EM-1220 and EM-1222 messages that display for the new card before proceeding.

NOTE

Issues relating to data recovery on new WWN cards must be resolved at this point before proceeding to avoid invalid WWN data, errors, and operating problems. If EM-1220 messages indicate that IP addresses on installed WWN cards do not match, follow instructions in the message to recover the IP address so that both cards use the same address.

6. Determine the active CP by entering the `haShow` command.

7. On the active CP, run the `wwnrecover` command and specify the WWN card that you replaced (WWN 2 or WWN 1) when prompted.

8. If `wwnrecover` messages prompt for a system reboot, reboot both CPs to ensure the system is running with valid WWN card data.

9. Enter the `hafailover` command to force failover so that the standby CP becomes the active CP.

This command is necessary so that the correct IP address for the new card displays for the `ipaddrshow` command. For more information on these commands, refer to the *Brocade Fabric OS Command Reference*.

10. Verify the new card settings by running the following commands and comparing the output with the original `supportsave data`:

- `licenseidshow`
- `ipaddrshow`
- `switchname`
- `chassisname`
- `wwncardshow ipdata`
- `chassisshow` (look at the WWN and Chassis information at the bottom)

11. If replacing the second WWN card, repeat steps 1-11 for the other card.

12. Install the WWN bezel. Orient the bezel on the chassis. Insert and tighten the screws.

13. Pack faulty WWN cards in the packaging provided with the replacement cards, and return them to Brocade Support for failure analysis (FA).

Power-down replacement

Use these procedures when you can interrupt system operation and replace one or both WWN cards with the system powered down.

Use this procedure if Brocade Customer Support has determined that a WWN card needs replaced and you have received the replacement card. These procedures require use of the `wwnrecover` utility.

NOTE

You can use this procedure if replacing one or both WWN cards, however you *must* use this procedure if replacing both WWN cards. If Brocade support has determined that both WWN cards need replaced, you must power-down the chassis, and then replace both WWN cards as a matched pair. Obtain replacement cards through your Brocade product support representative.

Follow electrostatic discharge (ESD) precautions. Wear a wrist grounding strap connected to chassis ground (if the chassis is plugged in) or a bench ground.

**DANGER**

For safety reasons, the ESD wrist strap should contain a series 1 megaohm resistor.

NOTE

Be aware that if replacing both WWN cards, the IP addresses on the new WWN cards will be in effect when the chassis powers up. If these IP addresses are different from the previous cards, then you will not be able to establish ssh or other sessions that use the previous IP addresses. You can change IP addresses on the new cards using the `ipaddrset` command.

1. Unpack the replacement WWN card(s) and save the packaging for the faulty WWN card(s).
The WWN cards and cables are labeled #1 for the left slot and #2 for the right slot.
2. Power down the chassis and remove the defective WWN card(s) following appropriate steps under [Removing the WWN card and WWN bezel \(logo plate\)](#).

NOTE

There are two WWN cards located beneath the WWN bezel (logo plate). As you are facing the bezel, WWN 1 is located on the left side, and WWN 2 is on the right.

3. Install the replacement WWN card into the empty slot.
When replacing cards, hold each card by the edges and insert the WWN cable onto the WWN module until the cables are fully seated.
4. Install the replacement WWN card into the empty slot.
When replacing cards, hold each card by the edges and slide the card into the chassis. Use the Phillips screwdriver and the screws to secure the WWN card to the chassis.
5. Power on the chassis and wait for five minutes for the chassis to boot.
6. Verify that the new WWN card is correctly connected by noting if the LEDs on the card reflects the status of the components.

NOTE

The LEDs may take up to two minutes after WWN card installation to begin functioning.

7. Resolve any issues flagged by RASlog EM-1220 and EM-1222 messages that display for the new card(s) before proceeding.

NOTE

Issues relating to data recovery on new WWN cards must be resolved at this point before proceeding to avoid invalid WWN data, errors, and operating problems.

8. Determine the active CP by entering the `haShow` command.
9. On the active CP, run the `wwnrecover` command and specify WWN 2 card for recovery when prompted in `wwnrecover` output messages. Refer to [Using wwnrecover](#) for more information on this command.
10. If `wwnrecover` messages prompt for a system reboot, reboot both CPs to ensure the system is running with valid WWN card data.
11. Verify the new card settings by running the following commands and comparing the output with the original `supportsave data`:
 - `licenseidshow`
 - `ipaddrshow`
 - `switchname`
 - `chassisname`
 - `wwncardshow ipdata`
 - `chassisshow` (look at the WWN and Chassis information at the bottom)
12. Run the `switchcfgpersistentenable` command to persistently enable each logical switch, that was disabled before removing the WWN card(s):

```
switch:FID128:root> switchcfgpersistentenable
Switch's persistent state set to 'enabled'
```
13. Install the WWN bezel on the chassis.
 - a) Orient the bezel on the chassis.
 - b) Insert and tighten the screws.
14. Pack faulty WWN cards in the packaging provided with the replacement cards, and return them to Brocade Support for failure analysis (FA).

Removing the WWN card and WWN bezel (logo plate)

Two WWN cards located beneath the WWN bezel (logo plate). As you are facing the bezel on the non-port-side of the chassis, WWN 1 is located on the left side, and WWN 2 is on the right. When cards have been determined faulty and the replacement WWN cards have been received, complete the following steps to remove the bezel and faulty WWN cards.

Follow electrostatic discharge (ESD) precautions. Wear a wrist grounding strap connected to chassis ground (if the chassis is plugged in) or a bench ground.



DANGER

For safety reasons, the ESD wrist strap should contain a series 1 megaohm resistor.

1. Open a Telnet session to the chassis and log in to the active CP as admin. The default password is "password".
2. Verify that you are logged in to the active CP. Run the `haShow` command to determine the active CP.
3. Run the `supportsave` command on the active CP to capture all settings. If any problem occurs during the replacement, the `supportsave` information will be important for solving the problem.
4. Run the following commands on the chassis before replacing the cards so that the data can be verified after the replacement:
 1. `licenseidshow`
 2. `ipaddrshow`
 3. `switchname`
 4. `chassisname`
 5. `wwncardshow ipdata`
 6. `chassisshow` (look at the WWN and Chassis information at the bottom)

7. `ficonshow switchrnid` (FICON/mainframe environments only)
8. `configupload`

The factory serial number and the sequence number in the following outputs should match, except in the `ficonshow switchrnid`, which will have a number appended to the front indicating that the logical switch number, if virtual fabrics is enabled:

```
switch:FID128:admin> chassisshow
<output truncated>
WWN Unit: 1
Header Version:          2
Power Consume Factor:    -1
Factory Part Num:        60-1000491-05
Factory Serial Num:      AFX2533G001
Manufacture:             Day: 19 Month: 1 Year: 2012
Update:                  Day: 5 Month: 5 Year: 2014
Time Alive:              756 days
Time Awake:              3 days
```

```
WWN Unit: 2
Header Version:          2
Power Consume Factor:    -1
Factory Part Num:        60-1000491-05
Factory Serial Num:      AJX0416G02H
Manufacture:             Day: 12 Month: 8 Year: 2011
Update:                  Day: 5 Month: 5 Year: 2014
Time Alive:              897 days
Time Awake:              3 days
```

```
Chassis Factory Serial Num: AFY2530G00S
```

```
switch:admin> ficonshow switchrnid
{
  {Switch WWN           Flag Parm
  10:00:00:05:1e:95:b1:00 0x00 0x200a00
  Type number:          SLKWRM
  Model number:         DCX
  Manufacturer:         BRD
  Plant of Manufacture: CA
  Sequence Number:      0AFX2533G001
  tag:                  b6ff
}
```

5. If performing the power-down replacement procedure, perform the following steps. If hot-swapping WWN cards, skip to step 6.
 - a) Log in to the chassis and execute the `switchcfgpersistentdisable` command on the main switch and other logical switches. The `switchcfgpersistentdisable` command disables the switches, and ensures they remain disabled after the power is cycled. This allows you to check all the settings so that you can verify the settings before placing the chassis back into production.

```
switch:admin> switchcfgpersistentdisable
Switch's persistent state set to 'disabled'
```

If there are other logical switches on your chassis, use the `setcontext` command to connect to all the other switches and then run `switchcfgpersistentdisable` on these switches as well.

- b) Power down the entire chassis.
6. Remove the screws from the WWN bezel on the back of the chassis. Pull the bezel away from the chassis and set it aside. The two WWN cards are now visible.

Figure 48: Removal and replacement of the WWN bezel (logo plate) and WWN card

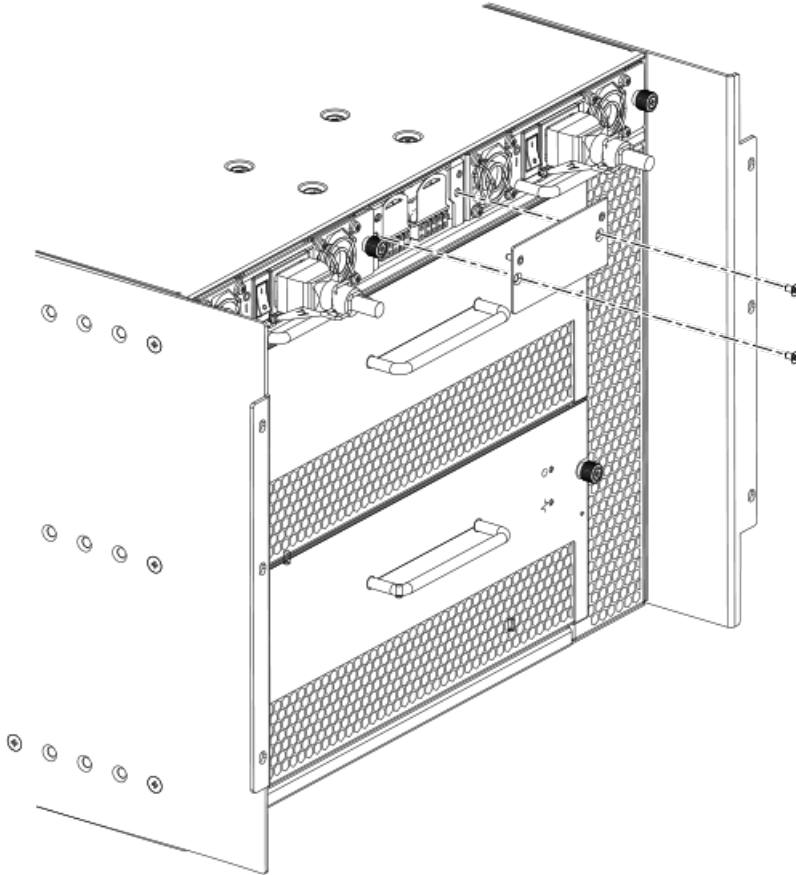
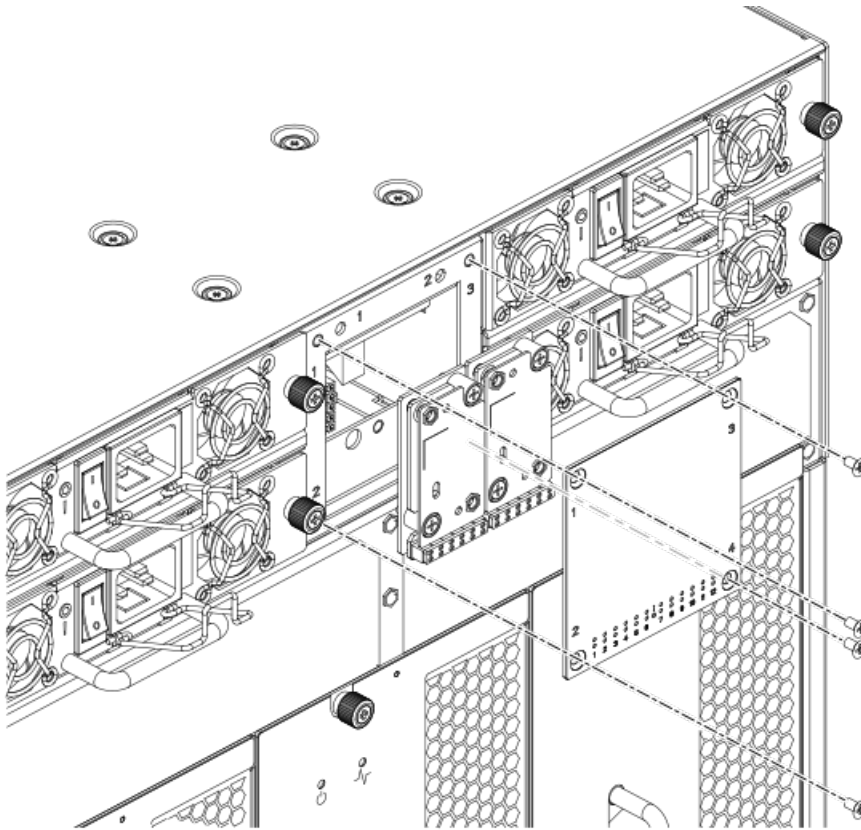

Figure 49: Removal and replacement of the WWN bezel (logo plate) and WWN card

7. Use a Phillips screwdriver to unscrew the screws that secure the WWN card to the chassis.
8. Depending on the WWN card removed, label the card and cables with #1 for the left side and #2 for the right side for future reference.
9. Disconnect the WWN cable by depressing the cable connector latch and pulling the connector from the WWN module.
10. Hold the WWN card by its edges and gently pull it out from the chassis.
11. Set the WWN card on a static-free surface, such as a grounding pad.

Transceiver and fiber optic cable removal and replacement

Use the procedures in this section to remove and replace fiber optic cables and the various types of transceivers supported on the device.

Blade	Transceiver	Auto-negotiate/Fixed	Speeds supported(xGbps)
FC8-32E and FC8-48E	SFP+	Auto negotiate	2, 4, and 8
FC8-64	mSFP	Auto negotiate	2, 4, and 8
FC16-32 and FC16-48	SFP+	Auto negotiate	2, 4, 8, and 16
FC16-32 and FC16-48	10-Gbps SFP+	Fixed	10
Fcoe10-24	10-GbE SFP+ (only optical)	Fixed	10
FC16-64 CR16-4/8	QSFP	Auto negotiate	4, 8, and 16.

Blade	Transceiver	Auto-negotiate/Fixed	Speeds supported(xGbps)
CR16-4/8	QSFP	Fixed	16

Time and items required

The replacement procedure for a transceiver takes less than five minutes.

Items required

The following items are needed to replace a transceiver:

- Replacement mSFP, SFP, SFP+, or XFP
- Optical transceiver extraction tool (for SFP, SFP+, and XFP transceivers)

Most Brocade switches and backbones come with a transceiver extraction tool and holster. The extraction tool is designed to remove transceivers from switches and blades where the space is limited.

Figure 50: Optical transceiver (SFP+) extraction tool



Removing an SFP+ transceiver

Complete the following steps to remove an SFP+ transceiver.

1. Remove any cables that are inserted into the transceiver. Use the extraction tool to open the cable latching mechanism.
2. Using the hooked end of the tool, pull the bail (wire handle) away from its pivot point and out, sliding the transceiver out of the switch or blade.

The 16 Gbps SFP+ transceivers have an attached pull tab like the mSFPs. Instead of using the tool, simply grasp the pull tab and pull straight out to remove the 16 Gbps SFP+ from the switch or blade. Refer to the illustration for the mSFP transceiver for the basic appearance of the 16 Gbps transceiver.

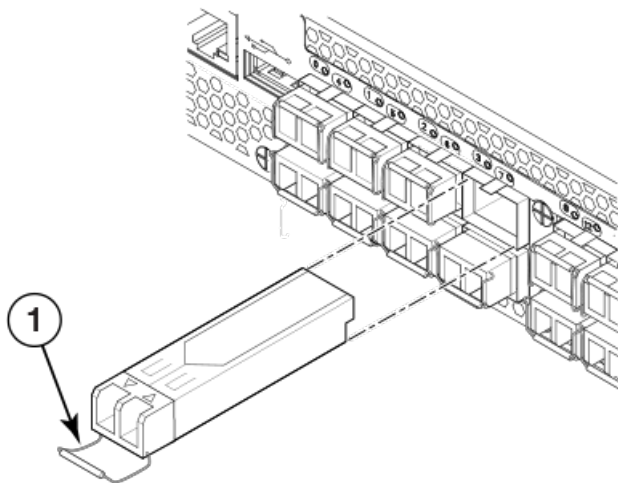
Figure 51: Replacing an optical transceiver

1. Bail

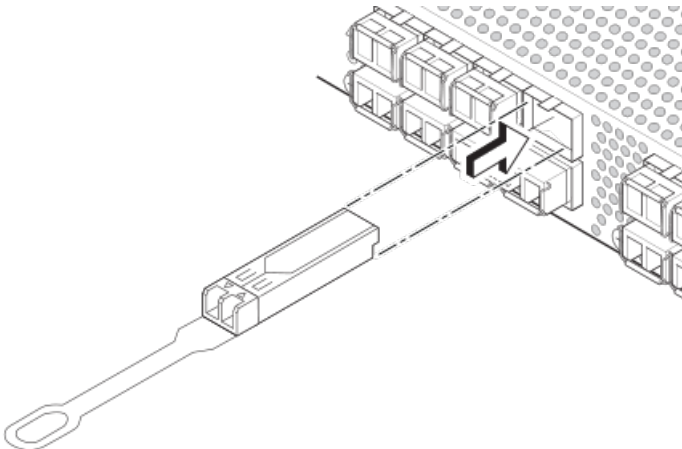
Figure 52: Replacing a 16 Gbps SFP+ optical transceiver

Replacing an SFP+ transceiver

Complete the following steps to replace an SFP+ transceiver.

1. Making sure that the bail (wire handle) is in the unlocked position, position the optical transceiver so that the key is oriented correctly to the port. Insert the transceiver into the port until it is firmly seated and the latching mechanism clicks; then close the bail.

The 16 Gbps SFP+ transceivers do not have bails. Use the tab on the 16 Gbps SFP+ transceivers to help gently push the transceiver into the port. Do not push so hard as to bend the tab.

Transceivers are keyed so that they can only be inserted with the correct orientation. If a transceiver does not slide in easily, ensure that it is correctly oriented.

2. Position a cable so that the key (the ridge on one side of the cable connector) is aligned with the slot in the transceiver. Insert the cable into the transceiver until the latching mechanism clicks.

Cables are keyed so that they can be inserted in only one way. If a cable does not slide in easily, ensure that it is correctly oriented. Do not insert a cable intended for an mSFP transceiver into a regular SFP+ transceiver. You may damage the cable. Do not force a standard SFP cable into an mSFP transceiver. You may damage the transceiver.

Removing and replacing an mSFP optical transceiver and cable

Use the procedures in this section to remove and replace mSFP transceivers. Follow these guidelines while removing and replacing mSFP transceivers.

- Do not use the SFP+ extraction tool to remove the mSFP transceivers.
- The mSFP transceivers are used only with the FC8-64 port blade. Narrower OM-3 LC cables are used to connect the FC8-64.
- It is recommended that the optical cable should be either removed from or inserted into the mSFP while the transceiver is out of the blade due to the port density.
- mSFP optical transceivers should not be inserted into ports intended for SFP+ transceivers. They will be faulted on power-up for Fabric OS 7.0.0 and later.
- Cables for mSFP transceivers should not be used with standard SFP+ transceivers.
- The pull tabs are not designed to be bent. Doing so may result in damage to the pull tab.

Removing an mSFP transceiver

Complete the following steps to remove an mSFP transceiver.

1. Grasp the pull tab firmly and pull the unit out of the port.
2. Remove the cable from the transceiver.

Figure 53: Optical mSFP transceiver

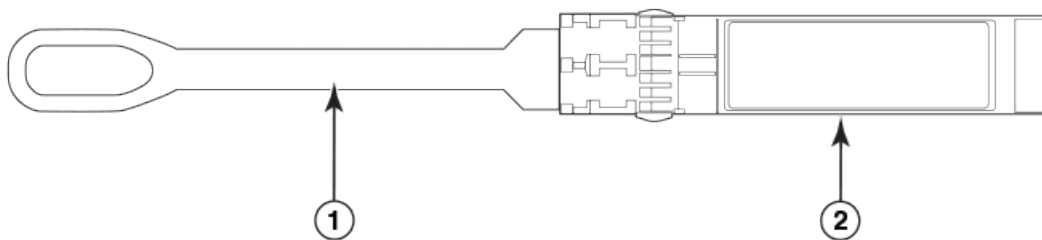

1. Pull tab
2. mSFP transceiver

Replacing an mSFP transceiver

Complete the following steps to replace an mSFP transceiver.

1. Insert the cable into the new transceiver until the latching mechanism clicks.
2. Position the optical transceiver so that the key is oriented correctly to the port. Insert the transceiver into the port until it is firmly seated and the latching mechanism clicks.

Transceivers are keyed so that they can only be inserted with the correct orientation. If a transceiver does not slide in easily, ensure that it is correctly oriented.

Removing and replacing a QSFP and cable

Use this procedure to remove and replace QSFP transceivers and cables supported on the FC16-64 port blades and core switch blades. Do not use the extraction tool to remove the QSFP transceivers. Follow these guidelines while removing and replacing QSFP transceivers:

- The QSFP transceivers are used only with the FC16-64 port blades and core switch blades. Refer to "Qualified transceivers for the FC16-64 and CR16-x blades" in this publication for a list of QSFPs qualified for these blades.
- For QSFPs with separate transceivers and optical cables, it is recommended that the cable be either removed from or inserted into the QSFP while the transceiver is out of the blade due to the port density.
- The pull tabs on QSFPs are not designed to be bent. Doing so may result in damage to the pull tab.

Qualified transceivers for the FC16-64 and CR16-x blades

The following table shows the qualified transceivers for the FC16-64 port blade and the CR16-4/8 core blades.

Table 19: Qualified transceivers for FC16-64 port blade and the CR16-x core blades

Brocade part number	Part type	Cable length	Port speeds	Supported blades
57-1000310-01	QSFP transceiver with integrated 3 m optical cable	Supports 2 km	16 Gbps	CR16-4/8
57-1000294-02	QSFP transceiver	100 m OM4	Auto-negotiable 4-, 8-, and 16-Gbps	FC16-64 and CR16-4/8
57-1000267-01	QSFP transceiver	100 m OM4	Only fixed 16-Gbps	CR16-4/8
57-0000090-01	QSFP transceiver	50 m OM3	Only fixed 16-Gbps	CR16-4/8

Removing a QSFP transceiver and cable

QSFP transceivers are of three types:

- Transceiver with separate cable and a bail-type latch.

Figure 54: QSFP transceiver (bail open)

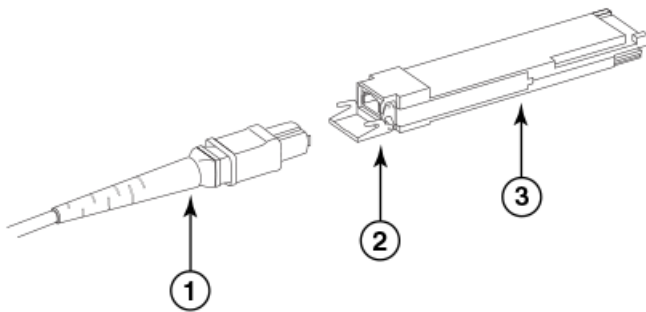

1. MTP cable
2. Bail
3. Transceiver

- Transceiver with integrated cable and pull-tab.

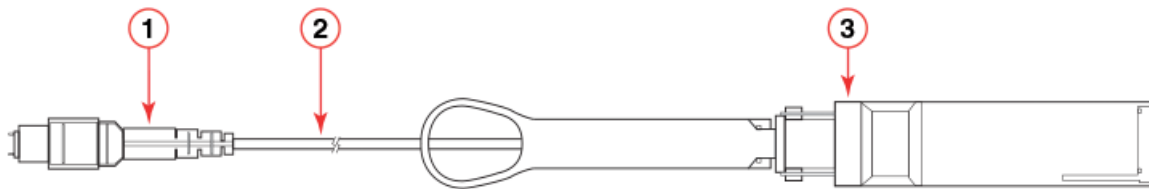
Figure 55: 2 km LWL QSFP transceiver with pull-tab and integrated cable

1. MTP 1x12 fiber male connector
2. Integrated 3 meter MTP cable
3. Transceiver with pull-tab

- Transceiver with separate cable and pull-tab. A third type of transceiver has a pull-tab to remove the transceiver from the blade port connector (like shown in previous illustration) but a separate MTP cable that plugs into the transceiver.

Complete the following steps to remove a MTP cable and transceiver.

1. For a transceiver with a bail-type latch and removable cable, perform the following steps:
 - a) Remove the cable by grasping the rubber housing on the end of the cable and pulling it straight out of the QSFP transceiver.
 - b) If the QSFP transceiver also needs to be replaced, remove it by rotating the bail down and using the bail to pull the transceiver out of the connector on the blade.
 - c) Repeat step a or b for each cable or transceiver that requires replacement.
2. For a transceiver with integrated cable and pull-tab, perform the following steps:
 - a) Grasp the pull tab and firmly, but gently, pull until transceiver releases from connector and blade port.
 - b) Slide the transceiver and cable from the port.
 - c) Repeat step a or b for each cable or transceiver that requires replacement.
3. For a transceiver with removable cable and a pull-tab, perform the following steps:
 - a) Remove the cable by grasping the rubber housing on the end of the cable and pulling it straight out of the QSFP transceiver.
 - b) If the QSFP transceiver also needs to be replaced, remove it by grasping the pull tab and firmly, but gently, pulling until the transceiver releases from connector and blade port.

Replacing a QSFP transceiver and cable

Complete the following steps to replace a QSFP transceiver and fiber optic cable.

1. If replacing a transceiver that has a separate cable and a bail-type latch, perform the following steps:
 - a) Grasp the bail of the new QSFP and push the QSFP into the connector in the blade port until it is firmly seated. The QSFP is keyed to fit into the connector in one way.

The status LED initially blinks amber after installation, then displays steady amber.
 - b) Grasp the QSFP cable by the rubber housing and push it into the QSFP transceiver until it is firmly seated. The cable housing is keyed to fit into the QSFP in one way.

The status LED displays steady amber until both ends of the cable are inserted and the link is established. When the link is fully established, the LED displays steady green.

- c) Repeat for each cable that requires replacement.
 - d) Once all the cables are attached, refer to the *Brocade Fabric OS Administration Guide* for the configuration procedure.
2. If replacing a transceiver that has an integrated cable and pull-tab, perform the following steps:
 - a) Align the transceiver with the blade port. Grasp the transceiver body and firmly, but gently, push it into the port. The transceiver is keyed to fit into the connector in one way
 - b) Press firmly on the front of the transceiver with your thumb to fully seat into the blade connector.
The status LED displays steady amber until both ends of the cable are inserted and the link is established. When the link is fully established, the LED displays steady green.
 3. Repeat step 1 or 2 for each transceiver that requires replacement.
 4. Once all the transceivers are installed, refer to the *Brocade Fabric OS Administration Guide* for the configuration procedure.

Chassis removal and replacement

This section describes how to remove and replace the chassis with its backplane. The basic steps are:

1. [Faulty chassis indicators.](#)
2. [Recording critical device and SAN information.](#)
3. [Disconnecting from network and fabric.](#)
4. [Removing components from the chassis.](#)
5. [Installing the replacement chassis.](#)
6. [Installing components into the new chassis.](#)
7. [Downloading the configuration.](#)
8. [Reconnecting the system to the network and fabric.](#)
9. [Verifying correct operation of system.](#)
10. [Verifying correct configuration of the fabric.](#)

NOTE

The device must be removed from the fabric and powered off to perform this procedure. Contact your support provider if you have any questions about whether the chassis requires replacement.

Time and items required

The chassis replacement takes approximately 3 hours.

The following items are required for the chassis replacement:

- Electrostatic discharge (ESD) grounding strap
- ESD grounding pads for protecting all blades and WWN cards
- Serial cable and workstation computer with a terminal emulator application (such as HyperTerminal for Windows systems or TIP for Solaris systems), required only if serial console session used
- Pallet jack or hydraulic or assisted lift that raises a minimum of 140 cm (55 in.) and carries a minimum of 113 kg (250 lb)
- A surface on which to place the old chassis, such as a second lift or the pallet originally provided with the old chassis
- #2 Phillips screwdriver

Faulty chassis indicators

Verify that replacement of the chassis is necessary. Ensure that the components are firmly seated when troubleshooting, and contact your support provider with any questions about whether the chassis should be replaced.

Any of the following events might indicate the need to replace the chassis:

- Visible mechanical damage to the chassis, including damage to sheet metal or card guides that prevents correct installation of a blade.
- Bent or damaged connectors on the backplane (the surface inside the chassis to which the blades connect).
- One or more components (such as a power supply, blower assembly, port blade, control processor blade, core switch blade, or WWN card) do not function properly even after the component was replaced.
- Intermittent FAULTY codes for blades. Reseat the blade and visually inspect the top ejector stiffening rail for possible wear or damage. It is important that the blade ejector handles not slip out during blade installation. If this happens, it is usually due to excessive wear or damage to the top ejector stiffening rail.
- The `psShow` or `fanShow` commands continue to show a faulty component even though the component was replaced.
- The `slotShow` command continues to show a faulty control processor, core switch, or port blade even though the blade was replaced.

Recording critical device and SAN information

Use a checklist, such as the following, to ensure that critical information is recorded for installing the new chassis. This information includes current chassis IP addresses, license keys, the new chassis serial number, and output from `supportShow`, `fabricShow`, and other commands. Save output from commands to text files listed in the table.

All commands must be entered from a CLI session (Telnet or serial) to the active CP blade unless otherwise indicated. For detailed information about Fabric OS commands, refer to the *Fabric OS Command Reference*.

Table 20: Critical information checklist

Checked?	Data	Notes
Configuration information		
	Location of "config-switch.txt" file	
	Location of "config-miscinfo.txt" file	
	IP address, subnet mask	
	WWN for the device	
SAN profile		
	Location of "SANbefor.txt" file	
	Notes regarding <code>nsshow</code> output	
	Notes regarding <code>nsallshow</code> output	
	Notes regarding <code>switchshow</code> output	
	Notes regarding <code>fabricshow</code> output	
Output from <code>licenseshow</code> command		
	License keys and other licensing data for licensed products enabled on device.	
Output from <code>supportshow</code> command		
	Location of "spptshow.txt" file	
	Notes regarding <code>supportshow</code> output	

Checked?	Data	Notes
Information about the new chassis		
	New factory serial number	
	New serial number (if available)	

1. Open a Telnet session and log in to the device as `admin`. The default password is `password`. Enable the logging function on your Telnet or serial console connection.
2. Back up the current configuration.

NOTE

If you are using the Virtual Fabric feature, you should run `configupload -vf` before running the `configupload` command to save the logical switch configuration.

- Enter `configUpload -all`; then enter the requested information at the prompts.

This command uploads the device configuration to the customer-defined FTP server, making it available for downloading. For more information about this command, refer to the *Brocade Fabric OS Command Reference*.

```
switch:admin> configupload
Protocol (scp or ftp) [ftp]: ftp
Server Name or IP Address [host]: 123.123.123.123
User Name [user]: Admin24
File Name [config.txt]: config-switch0.txt
Password:
Upload complete
switch:admin>
```

- Alternatively, you can save the configuration file to a Brocade USB device.

3. Record the WWN value: Enter `wwn`; then copy the command output into a file named `config-miscinfo.txt`.

```
switch:admin> wwn
10:00:00:60:69:00:00:0a
```

4. Record the IP address information.

Enter `ipAddrShow`; then copy the command output into the `config-miscinfo.txt` file.

```
switch:admin> ipaddrshow
Chassis
Ethernet IP Address: 10.33.60.85
Ethernet Subnetmask: 255.255.240.0
CP0
Ethernet IP Address: 10.33.60.86
Ethernet Subnetmask: 255.255.240.0
Host Name: cp0
Gateway IP Address: 10.33.48.1
CP1
Ethernet IP Address: 10.33.60.87
Ethernet Subnetmask: 255.255.240.0
Host Name: cp1
Gateway IP Address: 10.33.48.1
Backplane IP address of CP0 : 10.0.0.5
```

```

Backplane IP address of CP1 : 10.0.0.6
IPv6 Autoconfiguration Enabled: Yes
Local IPv6 Addresses:
chassis 0 stateless fd00:60:69bc:63:205:1eff:fe39:e45a/64 preferred
chassis 0 stateless fec0:60:69bc:63:205:1eff:fe39:e45a/64 preferred
cp 0 stateless fd00:60:69bc:63:205:1eff:fe40:6230/64 preferred
cp 0 stateless fec0:60:69bc:63:205:1eff:fe40:6230/64 preferred
cp 1 stateless fd00:60:69bc:63:205:1eff:fe39:ff2a/64 preferred
cp 1 stateless fec0:60:69bc:63:205:1eff:fe39:ff2a/64 preferred
IPv6 Gateways:
cp 0 fe80:60:69bc:63::3
cp 0 fe80:60:69bc:63::1
cp 0 fe80:60:69bc:63::2
cp 1 fe80:60:69bc:63::1
cp 1 fe80:60:69bc:63::2
cp 1 fe80:60:69bc:63::3

```

5. Display and record the manufacturer serial numbers.

Enter `chassisShow`; then copy the command output into the `config-miscinfo.txt` file.

"Factory Serial Num" and "Serial Num" are listed under "Chassis/WWN Unit 1." If the current WWN cards are the original cards, the factory serial number listed is the same as the chassis serial number.

```

switch:admin> chassisshow
Chassis Backplane Revision: 1F
SW BLADE Slot: 1
Header Version:          2
Power Consume Factor:    -50
Factory Part Num:        60-0001532-03
Factory Serial Num:      KP000000195
Manufacture:             Day:  1 Month:  1 Year: 2007
Update:                  Day: 14 Month:  3 Year: 2012
Time Alive:              187 days
Time Awake:              3 days
<output truncated>
CHASSIS/WWN Unit: 1      (in same assembly as WWN Unit: 2)
Header Version:          2
Power Consume Factor:    -3
Factory Part Num:        60-0001501-07
Factory Serial Num:      FT02X805BE2
Manufacture:             Day: 26 Month:  3 Year: 2007
Update:                  Day: 14 Month:  3 Year: 2009
Time Alive:              207 days
Time Awake:              3 days
<output truncated>
switch:admin>

```

6. Create a SAN "profile" by entering and recording the information provided by the following commands:

- `nsShow`
- `nsAllShow`
- `switchShow -qsfp`
- `fabricShow`

Copy the command output into a text file named "SANbefor.txt." After the device is restored to the fabric, this information can be used to verify that no unintentional changes have occurred to the fabric.

```
switch:admin> nsshow
Enter Pid COS PortName NodeName TTL
<output truncated>
switch:admin> nsallshow
 12 Nx_Ports in the Fabric
<output truncated>
switch:admin> switchshow
switchName: switch
<output truncated>
switch:admin> fabricshow
Switch ID Worldwide Name Enet IP Addr FC IP Addr Name
<output truncated>
switch:admin>
```

7. Enter `licenseShow`; then copy the command output into a text file named "licenseshow.txt."

```
switch:admin> licenseshow
S9bddb9SQbTAceeC:
Fabric license
eezeRRySff0fSe:
Remote Switch license
bzbzRcbcSc0c0SY:
Remote Fabric license
dSeR9RcSeeTfSAq:
Extended Fabric license
RyeSzRScycTzfT09:
Entry Fabric license
RyeSzRScycazfT0G:
Trunking license
RyeSzRScycS0fT09:
4 Domain Fabric license
```

8. Enter `supportShow`; then copy the command output into a text file named "spptshow.txt."

NOTE

The `supportShow` command has a very long output and time for completion. It may last 20 minutes or longer, depending on the size of the SAN.

This command displays support information from groups of preselected Fabric OS and Linux commands. Groups include `os`, `exception`, `port`, `fabric`, `services`, `security`, `network`, `portlog`, `system`, `extend`, `filter`, `ficon`, `iswitch`, `asic_db`, `fcip`, `ag`, `dce_hsl`, and `crypto`. This provides a backup of all the information that might be required by Technical Support and can be used after the device is restored to the fabric to verify that no unintentional changes have occurred to the fabric.

```
switch:admin> supportshow
version: 7.4.0
<output truncated>
switch:admin>
```

9. Record the cable connections between the chassis and the target device and ports.
10. Run `supportSave` on the active CP. The information recorded can be very important in case you have difficulties during the replacement process.

Disconnecting from network and fabric

Complete the following steps to disconnect the chassis from the network.

1. Shut down the device using the `sysShutdown` command on the active CP.

```
switch:admin> sysshutdown
This command will shutdown the operating systems on your switch.
You are required to power-cycle the switch in order to restore operation.
Are you sure you want to shutdown the switch [y/n]?y
HA is disabled
Stopping blade 1
Shutting down the blade....
Stopping blade 2
Shutting down the blade....
Stopping blade 8
Shutting down the blade....
Broadcast message from root (pts/1) Tue Jul 18 14:23:06 2008...
The system is going down for system halt NOW !!
```



DANGER

Disconnect the power cord from all power sources to completely remove power from the device.

2. Power off the chassis by flipping all AC power switches to the off position. (The power supply status LED should turn off.)
3. Remove the power cords from the power supplies and the power outlets.
4. Remove the chassis door.
5. Label the cables connected to all blades and record the connections.
6. Disconnect the cables from the SFP+ transceivers in the application and port blades and set them aside. If you have mSFP transceivers in FC8-64 port blades, or QSFP transceivers in FC16-64 port blades, remove the transceivers and cables together and set them aside. The SFP+ transceivers can be left in the port blades or removed.
7. Disconnect all cables from the control processor and core switch blades.
8. Disconnect any ICL or QSFP cables.

Removing components from the chassis

Follow electrostatic discharge (ESD) precautions when removing components. Wear a wrist grounding strap connected to chassis ground (if the device is plugged in) or a bench ground.

NOTE

Do not remove WWN cards from the chassis as new WWN cards are shipped preinstalled in the replacement chassis. Do not replace the WWN cards in the replacement chassis with the old WWN cards as this will result in licensing and return materials authorization (RMA) issues for your product. The original license will be transferred to the replacement chassis, based on the license identification (LID) of the new, preinstalled WWN card, through the RMA process. You should be provided a license for the new chassis through email. If you have not received this, contact your Brocade support representative.

**DANGER**

For safety reasons, the ESD wrist strap should contain a series 1 megaohm resistor.

1. Remove the chassis door ([Chassis door removal and replacement](#)) if not already done.
2. Remove the cable management comb ([Cable management comb removal and replacement](#)).
3. Remove the port blades or filler panels ([Port application and encryption blade removal and replacement](#) and [Blade filler panel removal and replacement](#)).
4. Remove the core switch blades (CR16-x) ([Core switch blade \(CR16-x\) removal and replacement](#)).
5. Remove the control processor blades (CP8) ([Control processor blade \(CP8\) removal and replacement](#)).
6. Remove the power supplies or filler panels ([Power supply removal and replacement](#)).
7. Remove the blower assemblies ([Blower assembly removal and replacement](#)).

Installing the replacement chassis

Complete the following steps to install the replacement chassis.

**DANGER**

Use safe lifting practices when moving the product.

**DANGER**

A completely empty Brocade DCX 8510-8 chassis weighs approximately 37.3 kg (82.2 lb) and requires a hydraulic or assisted lift to install it.

**DANGER**

Make sure the rack housing the device is adequately secured to prevent it from becoming unstable or falling over.

1. If the chassis is in a cabinet, remove it from the cabinet.
2. Place the chassis on a lift or on the shipping pallet provided with the original chassis.
3. Unpack the new chassis:
 - a) Cut the bands that encircle the packaging.
 - b) Remove the lid and the kits and foam from the top of the chassis.
 - c) Lift the cardboard box off the chassis and remove the plastic bag from around the chassis. Save the packing materials for use when returning the old chassis.
 - d) Leave the chassis on top of the plastic shipping tray if the chassis must be transported to the installation location.

NOTE

The device packaging does not incorporate a wood pallet and pallet brackets. The chassis sits on top of a plastic shipping tray.

4. Use a pallet jack or other assisted lift to transport the new chassis to the installation area. Doorways must be wider than 91 cm (36 in.) to accommodate the chassis on the pallet.
5. Use a lift to raise the chassis to the correct level. If installing the chassis in a cabinet, follow the instructions provided by the rack kit manufacturer.

Installing components into the chassis

Follow electrostatic discharge (ESD) precautions when installing new components. Wear a wrist grounding strap connected to chassis ground (if the device is plugged in) or a bench ground.

NOTE

New WWN cards are shipped preinstalled in the replacement chassis. Do not replace the WWN cards in the replacement chassis with the old WWN cards from chassis that you are replacing. This will result in licensing and return materials authorization (RMA) issues for your product. The original license will be transferred to the replacement chassis, based on the license identification (LID) of the new, preinstalled WWN card, through the RMA process. You should be provided a license for the new chassis through email. If you have not received this, contact your Brocade support representative.

**DANGER**

For safety reasons, the ESD wrist strap should contain a series 1 megaohm resistor.

1. Record the chassis serial number, SKU, and WWN printed on the chassis label. This label is located on the lower left corner of the chassis on the nonport side.
You may need this information to transfer licenses to the new chassis.
2. Record the chassis serial number, SKU, and WWN printed on the chassis label. This label is located on the lower right corner of the chassis on the port side.
You may need this information to transfer licenses to the new chassis.
3. Replace the blower assemblies ([Blower assembly removal and replacement](#)).
4. Replace the power supplies or filler panels ([Power supply removal and replacement](#)).
5. Replace the control processor blades (CP8) ([Control processor blade \(CP8\) removal and replacement](#)).
6. Replace the core switch blades (CR16-x) ([Core switch blade \(CR16-x\) removal and replacement](#)).
7. If ICL cables are not used, insert EMI plugs in the ICL sockets in the core switch blades (CR16-x).
8. Replace the port blades or filler panels ([Port application and encryption blade removal and replacement](#) and [Blade filler panel removal and replacement](#)).
9. Replace the cable management comb ([Cable management comb removal and replacement](#)).
10. Connect the power cords to the power supplies and the power outlets.
11. Replace the chassis door ([Chassis door removal and replacement](#)).
12. Power on the device ([Providing power to the device](#)).
The device performs a power-on self-test (POST). The POST takes a minimum of three minutes and is complete when LED activity returns to the standard state.
13. Verify that the device is powered on and POST is complete (all power LED indicators on the blades should be a steady green).
14. Verify that all components are functioning correctly by checking their LEDs. If the LEDs do not indicate correct operation, try reinstalling the corresponding component.

Downloading the configuration

Once the chassis and its various components have been reassembled and powered back on, use the `configDownload` command to restore the original configuration. The `configDownload` command can be entered through a Telnet or serial session, but the device must have an Ethernet connection to the server name or IP address of the host for the download process to complete. For more information, refer to the `help configdownload` command or the *Brocade Fabric OS Command Reference*.

Complete the following steps to download the configuration.

1. Log in to the device as `admin`.

```
switch:admin> login
login: admin
password: xxxxxxxx
switch:admin>
```

NOTE

If you are using the Virtual Fabric feature, you must run `configdownload -vf` *before* running the `configdownload` command to restore the logical switch configuration.

2. Enter the `chassisDisable` command.
3. Enter the `configDownload` command.

```
switch:admin> configdownload -all
Server Name or IP Address [host]: 123.123.123.123
User Name [None]: Admin24
File Name [config.txt]: config-switch.txt
Password: xxxxxxxx
download complete
switch:admin>
```

4. Reboot the device.

Reconnecting the system to the network and fabric

Refer to the cable routing information recorded in Cable Routing table in this section for the following steps.

Complete the following steps to reconnect the device to the network and fabric.

1. Connect the CP blades to the local area network by following all steps in the following sections:

- [Establishing a serial connection to the device.](#)
- [Logging in to the serial console port.](#)
- [Configuring the IP addresses.](#)

NOTE

Once an Ethernet connection is established, the device can be accessed by remote connection using any of the available management tools, such as Telnet or Web Tools.

- [Establishing an Ethernet connection to the device.](#)

2. Reconnect the transceivers and cables to the port blades.

NOTE

The ports and cables used in trunking groups must meet specific requirements. For a list of these requirements, refer to the *Brocade Fabric OS Administration Guide*.

- a) Position one of the transceivers so that the key is oriented correctly to the port and insert the transceiver into the port until it is firmly seated and the latching mechanism clicks.
- b) Select the cable that corresponds to the port and position it so that the key (the ridge on one side of the cable connector) is aligned with the slot in the transceiver. Insert the cable into the transceiver until the latching mechanism clicks.
- c) Repeat step a and step b for the remaining ports.
- d) Organize the cables as required.

NOTE

Do not route cables in front of the air exhaust vents.

Verifying correct operation of system

Complete the following steps to verify the correct operation of the device.

1. Log in to the device as `admin`.

```
switch:admin> login
login: admin
password: xxxxxxxx
switch:admin>
```

2. Enter the `slotShow -m` command and verify that all the installed cards are detected and that their status is operational (enabled).

```
switch:admin> slotShow -m
Slot  Blade Type      ID   Model Name      Status
-----
  1    SW BLADE           97   FC16-32         ENABLED
  2    SW BLADE           77   FC8-64          ENABLED
  3    SW BLADE           97   FC16-32         ENABLED
  4    SW BLADE           97   FC16-32         ENABLED
  5    CORE BLADE         99   CR16-4          ENABLED
  6    CP BLADE           50   CP8             ENABLED
  7    CP BLADE           50   CP8             ENABLED
  8    CORE BLADE         99   CR16-4          ENABLED
  9    SW BLADE           96   FC16-48         ENABLED
 10    SW BLADE           77   FC8-64          ENABLED
 11    SW BLADE           96   FC16-48         ENABLED
 12    SW BLADE           77   FC8-64          ENABLED
switch:admin>
```

3. Verify that the device is functioning correctly by entering `switchShow` or `switchStatusShow`.

This `switchShow` command displays the device and port status information. The example is from a DCX 8510-8. The other backbone chassis are similar.

```
switch:FID128:admin> switchshow
switchName: DCX8510_8
switchType: 120.1
switchState: Online
switchMode: Native
switchRole: Subordinate
switchDomain: 80
switchId: fffc50
switchWwn: 10:00:00:05:1e:39:e4:5a
zoning: ON (ZONE_CONFIG_NAME)
switchBeacon: OFF
FC Router: OFF
Allow XISL Use: OFF
LS Attributes: [FID: 128, Base Switch: No, Default Switch: Yes, Address Mode 0]
Index Slot Port Address Media Speed State Proto
=====
  0      1      0    500000  --    4G  No_Module    FC
```

```

1      1      1      500100  --      4G  No_Module  FC
2      1      2      500200  --      4G  No_Module  FC
3      1      3      500300  --      4G  No_Module  FC
4      1      4      500400  --      4G  No_Module  FC
(output truncated)

```

4. Verify that all the IP address information is correct by entering `ipAddrShow` and checking the results against the IP information recorded in the `config-miscinfo.txt` file.

```

switch:admin> ipaddrshow
SWITCH
Ethernet IP Address: xxx.xxx.xxx.12
Ethernet Subnetmask: 255.55.0.0
Fibre Channel IP Address: 1.2.3.4
Fibre Channel Subnetmask: 255.255.255.0
CP0
Ethernet IP Address: xxx.xxx.xxx.10
Ethernet Subnetmask: 255.55.0.0
HostName : cp0
Gateway Address: xxx.xxx.xxx.1
CP1
Ethernet IP Address: xxx.xxx.xxx.11
Ethernet Subnetmask: 255.55.0.0
HostName : cp1
Gateway Address: .1
Backplane IP address of CP0 : 10.0.0.4
Backplane IP address of CP1 : 10.0.0.5
switch:admin>switch:admin>

```

Verifying correct configuration of the fabric

Copying the command outputs from this section into a file is recommended. You must be logged in with Admin privileges.

1. Create an "after" SAN profile by entering the following commands and copying the output to a text file named `SANafter.txt`:

- `nsShow`
- `nsAllShow`
- `switchShow`
- `fabricShow`
- `lscfg --show` (if using the Virtual Fabric feature)

```

switch:admin> nsshow
Type Pid      COS      PortName NodeName TTL(sec)
N      020f00;      3;10:00:00:01:73:00:29:46;10:00:00:01:73:00:29:46; na
      Fabric Port Name: 20:0f:00:60:69:90:03:f0
<output truncated>
switch:admin> nsallshow
{
  020f00 021fda 021fdc 021fe0 021fe1
5 Nx_Ports in the Fabric}
switch:admin> switchshow
switchName: rsl8-st03-dcx-01
<output truncated>

```

```

switch:admin> fabricshow
Switch ID Worldwide Name Enet IP Addr FC IP Addr Name
<output truncated>
switch:admin>lscfg --show
Created switches: 128(ds) 1 2(bs)
Port    0    1    2    3    4    5    6    7    8    9
-----
FID     1 | 1 | 1 | 1 | 1 | 128 | 128 | 128 | 128 | 128 |
<output truncated>
switch:admin>

```

2. Determine any differences between the information in the SANafter.txt file and the information in the SANbefor.txt file created earlier. In particular, look for differences in the following:
 - Device types
 - Number of devices
 - ISL and port states
 - Number of switches in the fabric
3. If an SCC policy exists on the active fabric where you are connecting the new chassis, modify the policy to include the WWN of the new chassis.
 - Refer to the *Brocade Fabric OS Administration Guide* for information on SCC policy.
 - Use the `wwn` command to determine WWN of chassis.
 - Use the `secPolicyAdd` command to modify an existing policy.
4. Resolve any issues or unintentional changes to the device or fabric:
 - If there are any mechanical problems, try reseating the associated component.
 - If the configuration information is not correct for the device, modify as required.
 - If other issues exist, contact your support provider.

Cable routing table

The following table is a 64-port template for a cable routing table. Make copies of the table to cover the total number of ports in the device.

Table 21: Cable routing table for 64 ports

Slot/port		Cable labels		Connected device	Slot/port of device
Slot	Port	Switch end	Device end		
	0				
	1				
	2				
	3				
	4				
	5				
	6				
	7				
	8				
	9				

Slot/port		Cable labels	Connected device	Slot/port of device
10				
11				
12				
13				
14				
15				
16				
17				
18				
19				
20				
21				
22				
23				
24				
25				
26				
27				
28				
29				
30				
31				
32				
33				
34				
35				
36				
37				
38				
39				
40				
41				
42				
43				
44				
45				
46				
47				
48				
49				

Slot/port		Cable labels		Connected device	Slot/port of device
	50				
	51				
	52				
	53				
	54				
	55				
	56				
	57				
	58				
	59				
	60				
	61				
	62				
	63				

Diagnostics and Troubleshooting

Introduction

For information about troubleshooting the entire fabric, refer to the *Fabric OS Troubleshooting and Diagnostics Guide*.

The device includes a number of diagnostic aids to assist with troubleshooting, including LEDs on the hardware, commands that display current status, diagnostic tests for hardware and software, and error messages. In addition, a number of managing and monitoring features are available, such as Fabric Manager, Web Tools, Fabric Watch, and Advanced Performance Monitoring.

If the device does not operate as expected, the following steps can be taken to diagnose the problem:

- Check the LEDs on system components on the front and back of the device and refer to the LED tables in the "System Monitoring" section for interpretation and recommended actions.
- Review the results of the last POST run by the device and refer to the "Interpreting POST and boot results" section for more information.
- Review the error logs. Refer to the *Fabric OS Troubleshooting and Diagnostics Guide* for more information.
 - Review RASlog entries.
 - Use the `sensorShow` command to determine the status of the hardware components.
 - Refer to "Diagnostics" in the "Diagnostics and Troubleshooting" section to run diagnostic tests.
 - Reboot the device or power entire chassis off and then on using procedures in [Providing power to the device](#) and [Powering off the chassis](#).

If the problem is still unresolved after these steps, contact your support provider.

Obtaining chassis and component status

The CLI commands in the following table provide status and environmental information about the chassis and its components. These commands provide information only, and they do not interrupt traffic flow. For more information about these commands, refer to the *Brocade Fabric OS Command Reference*.

Table 22: Environmental status and maintenance commands

Command	Information displayed
sensorShow	Temperature readings for the port blades
	Temperature readings for the CP blades
	Status and RPM of all operational fans
	Status of all operational power supplies
tempShow	Temperature readings for the port blades
	Temperature readings for the CP blades
psShow	Status of all operational power supplies
fanShow	Status and RPM of all operational fans
chassisShow	Serial number, time awake, and additional information about each component
slotShow	Slot occupancy
errShowerrDump	System error log. Refer to the <i>Brocade Fabric OS Message Reference</i> for more information on the messages in this log.

Interpreting POST and boot results

The device performs Power-On Self-Test (POST) by default each time the chassis is powered on, rebooted, or reset. The device can be rebooted using the `reboot` (to reboot each CP individually) or `fastBoot` commands. The `fastBoot` command reboots the switches without running POST. If the active CP blade is rebooted, it fails over to the standby CP blade.

POST

The device automatically performs POST each time it is powered on or reset.

To verify that POST has completed without error, do the following:

- Verify that all LEDs return to a normal state after POST completes.
If one or more LEDs do not return to a normal state, and this is not due to the device being set to beacon, refer to the relevant LED table to identify and correct the problem. For port blades, and CP and core switch blades, the `slotShow` command can be used to check the status of the slots. For information about turning beaconing on or off, refer to the *Brocade Fabric OS Administration Guide*.
- Verify that the switch prompt displays when POST completes.
If it does not display, POST was not successfully completed. Contact the device supplier for support.
- Review the system error log using the `errShow` or `errDump` commands.
Any errors detected during POST are written to the system log, which is accessible through the `errShow` command. For information about error messages, refer to the *Brocade Fabric OS Message Reference*.

POST includes the following steps:

1. Preliminary POST diagnostics are run.
2. Operating system is initialized.
3. Hardware is initialized.
4. Diagnostic tests are run on several functions, including circuitry, port functionality, ability to send and receive frames, all aspects of memory, parity, statistics counters, and serialization.

Boot

In addition to POST, boot includes the following steps after POST is complete:

1. Universal port configuration is performed.
2. Links are initialized.
3. Fabric is analyzed. If any ports are connected to other switches, the device participates in a fabric configuration.
4. The device obtains a domain ID and assigns port addresses.
5. Unicast routing tables are constructed.
6. Normal port operation is enabled.

Diagnostics

Diagnostic tests are automatically run during POST to check the status of the device. Any error messages generated during POST are sent to the error logs and to the serial console, if connected.

Diagnostic tests can also be run manually to test and troubleshoot the hardware and the firmware, including internal connections and circuitry, transceivers, and port cables. However, diagnostic tests are generally intended for use by support personnel.

NOTE

Error messages do not necessarily indicate that the device requires maintenance.

Each diagnostic test can be implemented by entering the related command through a Telnet or serial session. For a list of diagnostic tests and commands, refer to the *Brocade Fabric OS Administration Guide*.

All diagnostic tests are run at all supported link speeds. They might temporarily lock the transmit and receive speeds to a specific speed. Some diagnostic tests require interconnecting the ports to each other or using loopback plugs. If ports are interconnected, the media (cables and transceivers) at each end of the connection must be of the same type. For example, short wavelength media must be connected to short wavelength media, and likewise with long wavelength media and copper media.

For more information about diagnostic tests and how to run them, refer to the *Brocade Fabric OS Administration Guide* and the *Brocade Fabric OS Command Reference*. For information about system error messages (`errShow` or `errDump`), refer to the *Fabric OS Troubleshooting and Diagnostics Guide*.

Troubleshooting

The following table provides a list of issues, possible causes, and recommended actions.

Table 23: Troubleshooting the device

Issue	Possible cause	Recommended action
Entire chassis powers off automatically.	Power supplies are inadequate to support the installed components.	Add an additional power supply.
Several or all components are not operating.	One or both power cables may not be connected to a live source.	Ensure that both power cables are connected to live outlets.
	One or both AC power switches might be off.	Ensure that both AC power switches are on (AC switches light up green when on).
Serial connection is faulty or serial port logs have incorrect or missing information.	Serial cable is not connected correctly.	Ensure that the cable is firmly connected to workstation computer and to the device.
	Terminal emulator application parameters are not set correctly.	Ensure that the terminal emulator application is configured as follows: 9600 bits per second, 8 databits, no parity, 1 stop bit, no flow control.
	Serial port might be incompatible (only RS-232 is supported).	Ensure that the device is connected to an RS-232 port. RS-423 serial ports might experience difficulties due to corner-case incompatibilities of the standards.
	Pins on the serial cable or serial port might be damaged.	Remove the cable and inspect the pins on the cable and in the serial port. Do not reinstall if the pins on either component have any visible damage, as this could damage the pins on the other component. Replace the components as required.
CP Ethernet link speed is different than expected or a link cannot be established.	There might be a conflict with the CP Ethernet link speed negotiation set up by the network.	Specify the CP Ethernet link speed by typing the <code>ifModeSet</code> command. For more information about Ethernet connectivity to the device, refer to the LAN guidelines provided through the MyBrocade website.
Configuration data is inaccurate or cannot be accessed.	Chassis was powered off/on while a WWN card was uninstalled or failed.	Install an operational WWN card and power the system off/on again.

Issue	Possible cause	Recommended action
	The device was rebooted while an WWN card was uninstalled or failed.	
Initial setup results in IP address/Domain ID conflict.	The device was connected to the fabric before being configured.	Refer to the <i>Brocade Fabric OS Administration Guide</i> for configuration information.
LEDs on one or more components are changing rapidly or do not indicate a healthy state.	The device might be booting or running POST.	Verify that boot and POST are complete. The device requires a minimum of 3 minutes, usually, after power-on to complete POST.
	Beaconing might be on for the entire device or for individual components.	Determine whether beaconing is on by typing the <code>switchShow</code> command and determine whether switch beaconing or blade beaconing are on.
	Individual components might have failed.	Refer to the LED tables in the "System Monitoring" section for interpretation and recommended actions.
	Pins on the components might be damaged.	Remove the component from the chassis and inspect the pins on the component and inside the chassis. Do not reinstall if pins on either component are damaged, as this could damage pins on other components. Replace the parts as required.
None of the LEDs on a component are on.	Component might not be seated correctly.	Ensure that the device has power and the component is firmly seated. If the problem continues, enter the <code>sensorShow</code> command to determine the component status. If the component is a CP blade or port blade, enter the <code>slotShow</code> command to determine the status.
	Component might have failed.	Replace the component as necessary.
CP blades are failing over frequently.	There is excessive serial port activity.	Ensure that the serial port activity remains below specified amount.
	CP blade is attached to an Ethernet with high traffic loads.	Ensure that the Ethernet traffic remains below specified amount
	Chassis is overheated.	Enter the <code>tempshow</code> and <code>sensorShow</code> commands to check internal temperature. If components are overheating, shut down port blades as necessary to return the temperature to operating range. Also try moving the blades in the chassis because it is possible that airflow might not be adequate to cool everything in certain configurations.
One or more port blades have either shut down or failed POST as indicated by the error log.	Blades might be overheated.	Enter the <code>sensorShow</code> command to check the internal temperature readings. If components are overheating, shut down port blades as necessary to return the temperature readings to the operating ranges. Also try moving the blades in the chassis because it is possible that airflow might not be adequate to cool everything in certain configurations.

Issue	Possible cause	Recommended action
	Blades might be faulty.	Enter the <code>slotShow</code> command to determine status. For more information, enter the <code>diagDisablePost</code> command; then, use the <code>slotPowerOff [slot number]</code> and <code>slotPowerOn [slot number]</code> command. Resolve the source of the problem or replace the blade as required.
	Pins on the blade or the backplane might be damaged.	Remove the blade from the chassis and inspect the pins on the blade and on the backplane inside the slot. Do not reinstall if the pins on either component are damaged, as this could damage pins on other components. Replace the components as required.
An individual component is not operating as expected.	Component may not have power or may not be firmly seated.	Ensure that the component is receiving power (power LED should be on) and the component is firmly seated.
	Pins on the component or the backplane might be damaged.	Remove the component from the chassis and inspect the pins on the blade and inside the chassis. Do not reinstall if the pins on either component are damaged, as this could damage pins on other components. Replace parts as required.
	The component might have failed.	Enter the <code>tempshow</code> and <code>sensorShow</code> command to determine the component status. If the component is a CP blade or port blade, enter the <code>slotShow</code> command to determine the status. Replace the component as necessary.

Application and Encryption Blades

Introduction

This appendix provides details about the application and encryption blades that are available optionally for the device. Contact your device supplier for additional information.

FS8-18 blade

The FS8-18 encryption blade is a high performance 16-port autosensing blade with data cryptographic (encryption/decryption) and data compression capabilities designed for enterprises to secure their data against theft or unauthorized use and to compress tape data for maximum utilization of tape media. The encryption blade is a network-based solution that secures data-at-rest for heterogeneous tape drives, disk array LUNs, and virtual tape libraries.

The FS8-18 blade provides the following major features:

- 16 autosensing F_Ports, FL_Ports, E_Ports, EX_Ports, and M_Ports at 8 Gbps FC ports
- 16 SFP media interfaces
- Encryption engines
- Key management/generation
- Key management with these hardware interfaces:
 - Two 1000Base copper type media interfaces
 - One smart card interface
- Security supervisor tamper detection and response capability
- Common Criteria (CC) EAL-3 compliant

FX8-24 blade

The FX8-24 blade has 12 external Fibre Channel (FC) SFP ports supporting the Fibre Channel Routing Services and 10 external 1 Gigabit Ethernet (GbE or GE) SFP ports supporting the Fibre Channel Over IP (FCIP) feature. There are also 2 licensable external 10 Gigabit Ethernet (10-GbE or 10-GE) SFP ports supporting FCIP. It operates with the Brocade Fabric Operating System and can communicate with another FX8-24 or a Brocade 7800 for both Fibre Channel Routing Services and FCIP, or a Brocade AP7420 for Fibre Channel Routing Services. The GbE ports on the FX8-24 are not compatible with the GbE ports on the FR4-18i blade, the Brocade 7500 switch, and the Brocade 7840 switch.

NOTE

The port diagram on the front panel uses the abbreviations GE for 1-GbE ports and 10 GE for 10-GbE ports.

NOTE

The 10-GbE SFPs used in the FX8-24 blade and the 10-Gbps FC SFPs used in the FC16-32/48 blades are not interchangeable.

The FX8-24 operates in one of three modes: 1) ten 1-GbE ports, 2) ten 1-GbE ports and one 10-GbE port, or 3) two 10-GbE ports depending on licensing and subsequent configuration of GbE port mode. If operating in 10-GbE mode, the other end of the circuit must also be an FX8-24 operating in either 10-GbE mode or dual mode with the corresponding VE_ports in 10-GbE mode. All GbE ports on the blade can be configured to work with either copper or optical SFPs.

The FX8-24 blade is intended as a platform for FCIP and Fibre Channel Routing Services. Refer to the *Brocade Fabric OS Administration Guide* for information on configuring these features.

The FX8-24 blade provides the following hardware features:

- 12 autosensing FC ports with link speeds of 1, 2, 4, or 8 Gbps
- Ten GbE ports supporting FCIP with fixed link speed at 1 Gbps
- Two 10 GbE ports (licensable) supporting FCIP with fixed link speed at 10 Gbps

The FX8-24 blade also provides the following functionality features:

- FCIP
- Compression (on FC frames before FCIP encapsulation)
- FC Routing (licensable)
- FCIP Trunking (licensable) with network-based failure recovery (failover only) and load balancing
- Multiple circuits per trunk:
 - Four per trunk through the GbE ports
 - Ten per trunk through the 10 GbE ports
- SO-TCP with reorder resistance
- FastWrite over FCIP
- Tape pipelining over FCIP
- FICON XRC emulation and tape pipelining over FCIP (licensable)
- FICON CUP (licensable)
- Virtual E_Ports
- FCIP QoS
- Support for 200 ms RTT (on a limited number of GbE ports)
- Adaptive Rate Limiting (licensable)
- TCP performance graphing in Web Tools
- FCIP Tunnels:
 - A maximum of 10 FCIP Tunnels for all GbE ports
 - Four tunnels maximum per GbE port
 - Two 10 GbE ports can support up to ten FCIP tunnels each
 - Each FCIP tunnel is represented and managed as a virtual Fibre Channel E_Port
 - Fibre Channel Routing Services can be used over the FCIP link
 - The Link Cost is equal to the sum of all established/low metric (or currently active) circuits' MAX rates in the tunnel.
 - Fabrics connected through FCIP merge if the ports are configured as VE_Ports, and do not merge if they are configured as VEX_Ports. If VE_Ports are used in a Fibre Channel Routing Services backbone fabric configuration, then the backbone fabric merges, but the EX_Port-attached edge fabrics do not merge. For more information, refer to the *Brocade Fabric OS Administration Guide*.
- Up to three FC trunking groups:
 - Trunk group 0: FC ports 0, 1
 - Trunk group 1: FC ports 6, 7
 - Trunk group 2: FC ports 2, 3, 4, 5, 8, 9, 10, 11

A RoHS-compliant version of the FX8-24 blade is available. To determine if this blade is installed, enter the `chassisshow` command. Output for the Factory Part Number will be 60-1003135-XX. Downgrading to these FOS versions is also not recommended if this blade is installed.

FCOE10-24 blade

The FCOE10-24 blade has 24 Fibre Channel over Ethernet (FCoE) ports that enable the transmission of FC frames over an Ethernet network via encapsulation in standard Ethernet packets. This is enabled by adherence to Converged Enhanced Ethernet (CEE) standards, a low latency, lossless Ethernet standard. This does not require dedicated Ethernet lines, but rather can make use of existing Ethernet infrastructure to reduce costs.

NOTE

This blade cannot be used in the same chassis with an FC8-48E, FC8-64, FC16-48, FC16-64 port blades or any of the application blades (FX8-24).

The FCOE10-24 blade supports only optical cabling and transceivers (SFP+).

There are no licensing requirements for functionality on this blade.

The FCOE10-24 blade provides the following hardware features:

- 24 FCoE ports operating at 10 Gbps
- 32 FC ports operating at 8 Gbps through the backplane
- Hot pluggable
- I²C Management interface through the backplane
- JTAG support
- Blade power and status LEDs
- Link status LEDs per port

The FCOE10-24 blade also provides the following functionality features:

- FCoE switching
- CEE switching
- Layer 2 Ethernet protocols STP/MSTP/RSTP, 802.1q, and Link Aggregation (802.1ad)
- Standard Ethernet encapsulation
- End of row deployment

NOTE

With the switch in online state, if all the FCOE ports are shutdown, offline diags will continue to run. After this, the blade will be in inoperable state and you need to issue `slotpoweroff` and `slotpoweron` to recover.

Refer to the *Brocade Fabric OS Administration Guide* for information on configuring these features.

Limitations of FCOE10-24 blade

The following limitations have to be considered when using FCOE10-24 application blade with Fabric OS 7.3.0, on the DCX 8510-8 chassis:

- FCOE10-24 blade is supported only in slot 1 of the 8510-8 chassis.
- Supports maximum of one FCOE10-24 blade per 8510-8 chassis.
- FCOE10-24 blade can be installed concurrently with FC16-32 and FC8-32E blades only.
- FCOE10-24 blade cannot be used in the DCX 8510-8 chassis with FC16-48, FC16-48E, FC8-64 or FC16-64 blades.
- FCOE10-24 blade cannot be used in a DCX 8510-8 chassis with other intelligent or application blades.
- Support is limited to FCoE direct attach only.
- Upgrade and downgrade considerations are same as DCX.

NOTE

For complete list of limitations on the FCOE10-24 blade, refer to the Fabric OS Release Notes.

Port Numbering Templates

CR16-8 core blade port numbering

Figure 56: CR16-8 core blade port numbering

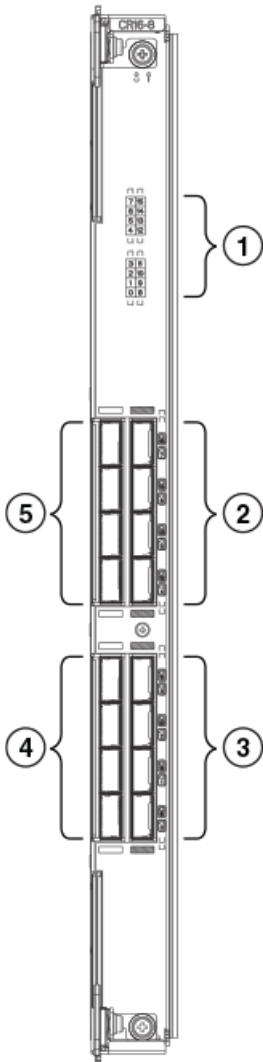

1. Port map
2. QSFP ports 12-15 (bottom to top)
3. QSFP ports 8-11 (bottom to top)
4. QSFP ports 0-3 (bottom to top)
5. QSFP ports 4-7 (bottom to top)

The following table shows the mappings from the numbered ports on the face of the core blade to the port mappings as shown by the `slotShow` command. Each external port maps to four actual ports.

Table 24: External port to slotShow port mapping for core blades

External port number	slotShow port numbers	External port number	slotShow port numbers
0	0-3	8	32-35
1	4-7	9	36-39
2	8-11	10	40-43
3	12-15	11	44-47
4	16-19	12	48-51
5	20-23	13	52-55
6	24-27	14	56-59
7	28-31	15	60-63

FC8-32E port blade port numbering

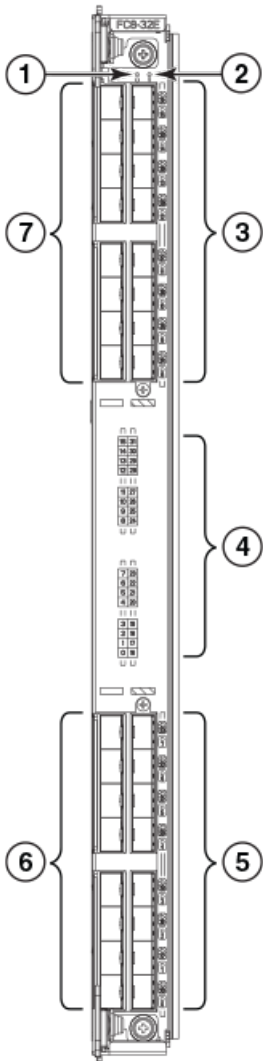
Figure 57: FC8-32E port blade port numbering

1. Blade power LED

2. Blade status LED
3. FC ports 24-31 (bottom to top)
4. Port and trunking group map (bottom to top)
5. FC ports 16-23 (bottom to top)
6. FC ports 0-7 (bottom to top)
7. FC ports 8-15 (bottom to top)

FC8-48E port blade port numbering

Figure 58: FC8-48E port blade port numbering

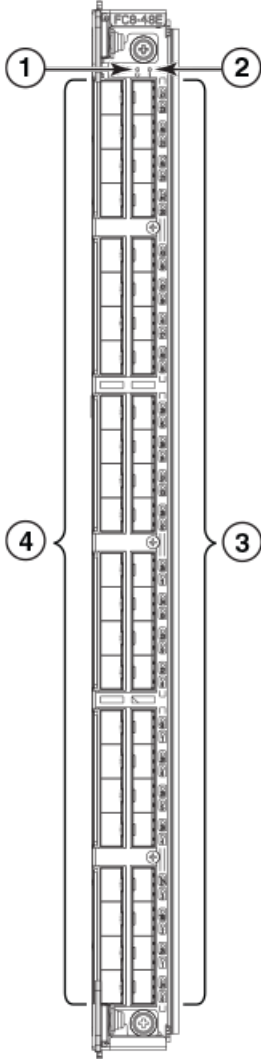

1. Blade power LED
2. Blade status LED
3. FC ports 24-47 (bottom to top)
4. FC ports 0-23 (bottom to top)

FC8-64 port blade port numbering

Figure 59: FC8-64 port blade port numbering

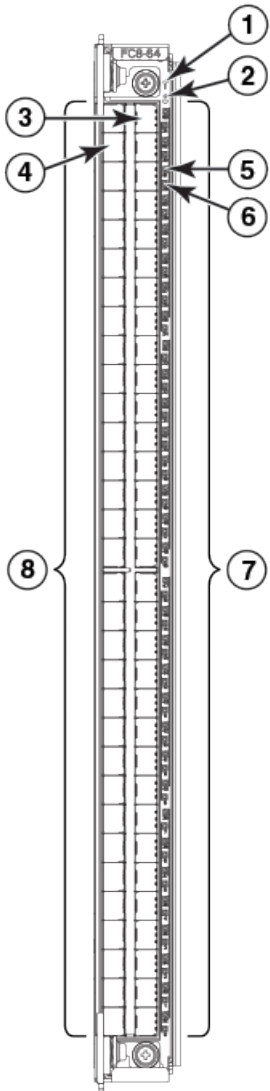

1. Blade status LED
2. Blade power LED
3. Port 63
4. Port 30
5. Port 61 status LED
6. Port 29 status LED
7. FC ports 32-63 (bottom to top)
8. FC ports 0-31 (bottom to top)

FC16-32 port blade port numbering

Figure 60: FC16-32 port blade port numbering

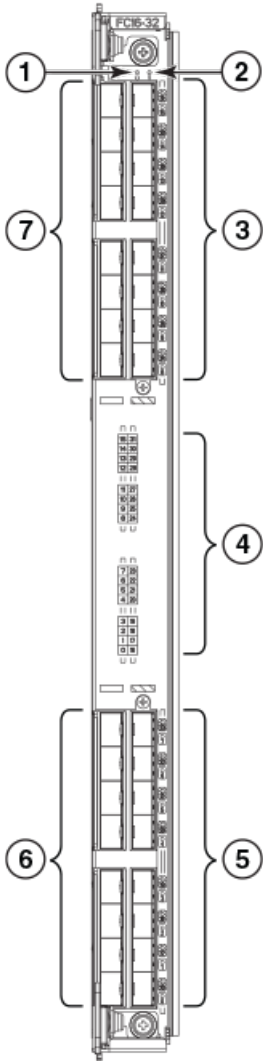

1. Blade power LED
2. Blade status LED
3. FC ports 24-31 (bottom to top)
4. Port and trunking group map
5. FC ports 16-23 (bottom to top)
6. FC ports 0-7 (bottom to top)
7. FC ports 8-15 (bottom to top)

FC16-48 port blade port numbering

Figure 61: FC16-48 port blade port numbering

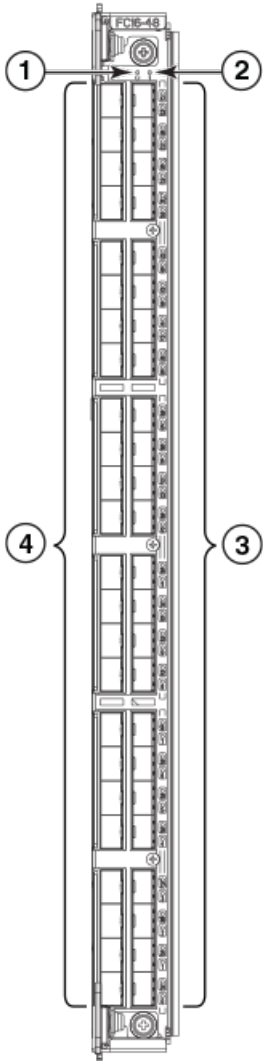

1. Blade power LED
2. Blade status LED
3. FC ports 24-47 (bottom to top)
4. FC ports 0-23 (bottom to top)

FC16-64 port blade port numbering

Figure 62: FC16-64 port blade port numbering

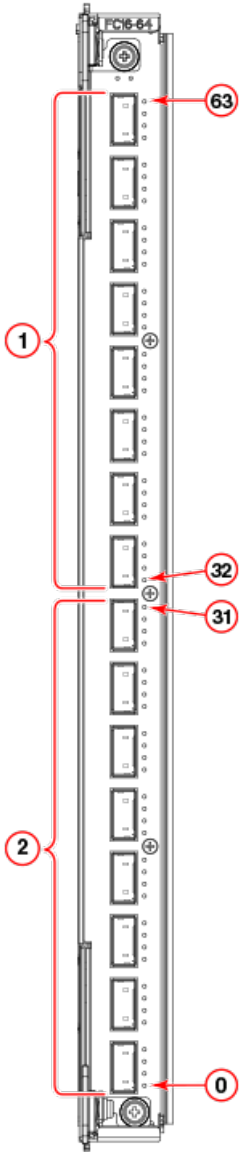

1. QSFP ports 8-15; FC ports 32-63 (bottom to top)
2. QSFP ports 0-7; FC ports 0-31 (bottom to top)

FCOE10-24 FCoE blade port numbering

Figure 63: FCOE10-24 FCoE blade port numbering

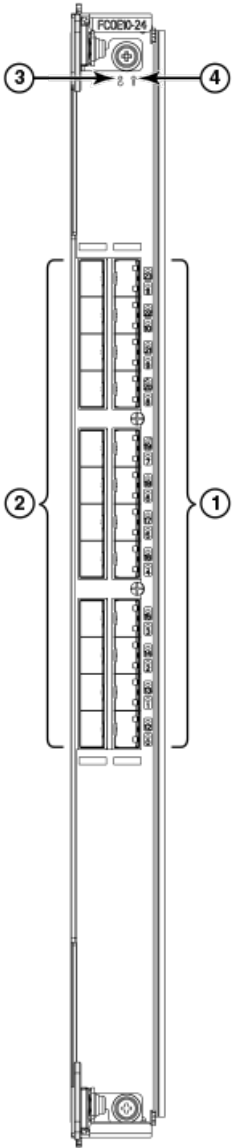

1. 10-GbE CEE ports 12-23 (bottom to top)
2. 10-GbE CEE ports 0-11 (bottom to top)
3. Power LED
4. Status LED

FS8-18 encryption blade port numbering

Figure 64: FS8-18 encryption blade port numbering

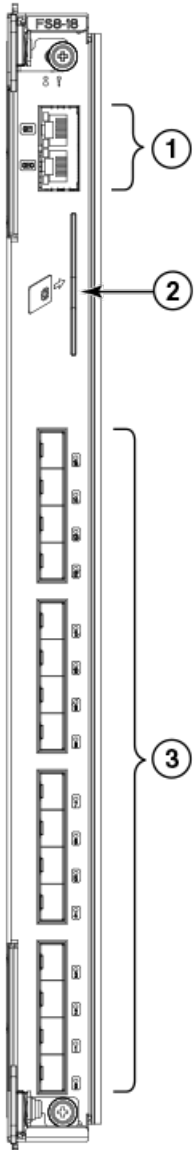

1. Gigabit Ethernet ports GE0-GE1
2. Smart card port
3. Fibre Channel ports 0-15 (bottom to top)

FX8-24 extension blade port numbering

Figure 65: FX8-24 extension blade port numbering

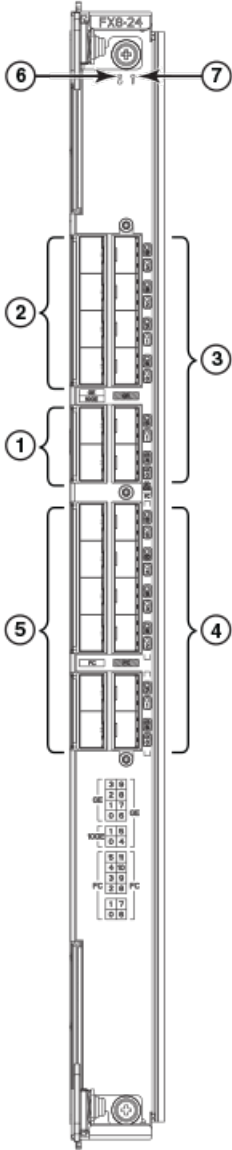

1. 10-GbE ports 0-1 (bottom to top)
2. 1-GbE ports 0-3 (bottom to top)
3. 1-GbE ports 4-9 (bottom to top)
4. FC ports 6-11 (bottom to top)
5. FC ports 0-5 (bottom to top)
6. Blade Power LED
7. Blade Status LED

Regulatory Statements

BSMI Statement (Taiwan)

警告使用者：

這是甲類的資訊產品，在居住的環境中使用時，可能會造成射頻干擾，
在這種情況下，使用者會被要求採取某些適當的對策。

Warning:

This is Class A product. In a domestic environment, this product may cause radio interference, in which case the user may be required to take adequate measures.

Canadian Requirements

This Class A digital apparatus meets all requirements of the Canadian Interference-Causing Equipment Regulations, ICES-003 Class A.

Cet appareil numérique de la classe A est conforme à la norme NMB-003 du Canada.

CE Statement

ATTENTION

This is Class A product. In a domestic environment, this product may cause radio interference, in which case the user may be required to take adequate measures.

The standards compliance label on this device contains the CE mark, which indicates that this system conforms to the provisions of the following European Council directives, laws, and standards:

- Electromagnetic Compatibility (EMC) Directive 2014/30/EU
- Low Voltage Directive (LVD) 2014/35/EU
- EN 55032/EN 55024 (European Immunity Requirements)
 - EN61000-3-2/IEC61000-3-2 (European and Japanese Harmonics Spec)
 - EN61000-3-3

China ROHS

China:						
部件名称	有毒有害物质或元素					
	铅 (Pb)	汞 (Hg)	镉 (Cd)	六价铬 (Cr (VI))	多溴联苯 (PBB)	多溴二苯醚 (PBDE)
光纤通道交换机 Fiber Channel Switch	✗	○	○	○	○	○
IP 交换机 IP Switch	✗	○	○	○	○	○
风扇/冷却组装件 Fan, Blower Assemblies	✗	○	○	○	○	○
线路板部件 PCBA Cards	✗	○	○	○	○	○
USB 闪存器 USB Flash Drive	✗	○	○	○	○	○
电源 Power Supply Kit	✗	○	○	○	○	○
光纤模块 SFP Optics	✗	○	○	○	○	○

FCC Warning (U.S. Only)

This equipment has been tested and complies with the limits for a Class A computing device pursuant to Part 15 of the FCC rules. These limits are designed to provide reasonable protection against harmful interference when the equipment is operated in a commercial environment.

This equipment generates, uses, and can radiate radio frequency energy, and if not installed and used in accordance with the instruction manual, might cause harmful interference to radio communications. Operation of this equipment in a residential area is likely to cause harmful interference, in which case the user will be required to correct the interference at the user's own expense.

Germany statement

Machine noise information regulation - 3. GPSGV, the highest sound pressure level value is 79.0 dB(A) in accordance with EN ISO 7779.

Maschinenlärminformations-Verordnung - 3. GPSGV, der höchste Schalldruckpegel beträgt 79.0 dB(A) gemäss EN ISO 7779.

KCC Statement (Republic of Korea)

A급 기기 (업무용 방송통신기기): 이 기기는 업무용(A급)으로 전자파적합등록을 한 기기이오니 판매자 또는 사용자는 이 점을 주의하시기 바라며, 가정외의 지역에서 사용하는 것을 목적으로 합니다.

Class A device (Broadcasting Communication Device for Office Use): This device obtained EMC registration for office use (Class A), and may be used in places other than home. Sellers and/or users need to take note of this.

VCCI Statement

この装置は、クラスA情報技術装置です。この装置を家庭環境で使用すると電波妨害を引き起こすことがあります。この場合には使用者が適切な対策を講ずるよう要求されることがあります。 VCCI-A

This is a Class A product based on the standard of the Voluntary Control Council for Interference by Information Technology Equipment (VCCI). If this equipment is used in a domestic environment, radio disturbance might arise. When such trouble occurs, the user might be required to take corrective actions.

Caution and Danger Notices

Cautions

A Caution statement alerts you to situations that can be potentially hazardous to you or cause damage to hardware, firmware, software, or data.

Ein Vorsichtshinweis warnt Sie vor potenziellen Personengefahren oder Beschädigung der Hardware, Firmware, Software oder auch vor einem möglichen Datenverlust

Un message de mise en garde vous alerte sur des situations pouvant présenter un risque potentiel de dommages corporels ou de dommages matériels, logiciels ou de perte de données.

Un mensaje de precaución le alerta de situaciones que pueden resultar peligrosas para usted o causar daños en el hardware, el firmware, el software o los datos.

Electrical Cautions



CAUTION

Use a separate branch circuit for each power cord, which provides redundancy in case one of the circuits fails.

VORSICHT	Es empfiehlt sich die Installation eines separaten Stromkreiszweiges für jede Elektroschnur als Redundanz im Fall des Ausfalls eines Stromkreises.
MISE EN GARDE	Utilisez un circuit de dérivation différent pour chaque cordon d'alimentation ainsi, il y aura un circuit redondant en cas de panne d'un des circuits.
PRECAUCIÓN	Use un circuito derivado separado para cada cordón de alimentación, con lo que se proporcionará redundancia en caso de que uno de los circuitos falle.



CAUTION

Before plugging a cable into any port, be sure to discharge the voltage stored on the cable by touching the electrical contacts to ground surface.

VORSICHT	Bevor Sie ein Kabel in einen Anschluss einstecken, entladen Sie jegliche im Kabel vorhandene elektrische Spannung, indem Sie mit den elektrischen Kontakten eine geerdete Oberfläche berühren.
MISE EN GARDE	Avant de brancher un câble à un port, assurez-vous de décharger la tension du câble en reliant les contacts électriques à la terre.
PRECAUCIÓN	Antes de conectar un cable en cualquier puerto, asegúrese de descargar la tensión acumulada en el cable tocando la superficie de conexión a tierra con los contactos eléctricos.



CAUTION

Static electricity can damage the chassis and other electronic devices. To avoid damage, keep static-sensitive devices in their static-protective packages until you are ready to install them.

VORSICHT	Statische Elektrizität kann das System und andere elektronische Geräte beschädigen. Um Schäden zu vermeiden, entnehmen Sie elektrostatisch empfindliche Geräte erst aus deren antistatischer Schutzhülle, wenn Sie bereit für den Einbau sind.
MISE EN GARDE	L'électricité statique peut endommager le châssis et les autres appareils électroniques. Pour éviter tout dommage, conservez les appareils sensibles à l'électricité statique dans leur emballage protecteur tant qu'ils n'ont pas été installés.

PRECAUCIÓN	La electricidad estática puede dañar el chasis y otros dispositivos electrónicos. A fin de impedir que se produzcan daños, conserve los dispositivos susceptibles de dañarse con la electricidad estática dentro de los paquetes protectores hasta que esté listo para instalarlos.
------------	---

**CAUTION**

If you do not install a module or a power supply in a slot, you must keep the slot filler panel in place. If you run the chassis with an uncovered slot, the system will overheat.

VORSICHT	Falls kein Modul oder Netzteil im Steckplatz installiert wird, muss die Steckplatztafel angebracht werden. Wenn ein Steckplatz nicht abgedeckt wird, läuft das System heiß.
MISE EN GARDE	Si vous n'installez pas de module ou de bloc d'alimentation dans un slot, vous devez laisser le panneau du slot en place. Si vous faites fonctionner le châssis avec un slot découvert, le système surchauffera.
PRECAUCIÓN	Si no instala un módulo o un fuente de alimentación en la ranura, deberá mantener el panel de ranuras en su lugar. Si pone en funcionamiento el chasis con una ranura descubierta, el sistema sufrirá sobrecalentamiento.

Danger Notices

A Danger statement indicates conditions or situations that can be potentially lethal or extremely hazardous to you. Safety labels are also attached directly to products to warn of these conditions or situations.

Ein Gefahrenhinweis warnt vor Bedingungen oder Situationen die tödlich sein können oder Sie extrem gefährden können. Sicherheitsetiketten sind direkt auf den jeweiligen Produkten angebracht um vor diesen Bedingungen und Situationen zu warnen.

Un énoncé de danger indique des conditions ou des situations potentiellement mortelles ou extrêmement dangereuses. Des étiquettes de sécurité sont posées directement sur le produit et vous avertissent de ces conditions ou situations.

Una advertencia de peligro indica condiciones o situaciones que pueden resultar potencialmente letales o extremadamente peligrosas. También habrá etiquetas de seguridad pegadas directamente sobre los productos para advertir de estas condiciones o situaciones.

Electrical Dangers

**DANGER**

Make sure that the power source circuits are properly grounded, and then use the power cord supplied with the device to connect it to the power source.

GEFAHR	Stellen Sie sicher, dass die Stromkreise ordnungsgemäß geerdet sind. Benutzen Sie dann das mit dem Gerät gelieferte Stromkabel, um es an die Stromquelle anzuschließen.
DANGER	Vérifiez que les circuits de sources d'alimentation sont bien mis à la terre, puis utilisez le cordon d'alimentation fourni avec le dispositif pour le connecter à la source d'alimentation.
PELIGRO	Verifique que circuitos de la fuente de corriente están conectados a tierra correctamente; luego use el cordón de potencia suministrado con el instrumento para conectarlo a la fuente de corriente

**DANGER**

For safety reasons, the ESD wrist strap should contain a series 1 megaohm resistor.

GEFAHR	Aus Sicherheitsgründen sollte ein EGB-Armband zum Schutz von elektronischen gefährdeten Bauelementen mit einem 1 Megaohm-Reihenwiderstand ausgestattet sein.
DANGER	Pour des raisons de sécurité, la dragonne ESD doit contenir une résistance de série 1 méga ohm.
PELIGRO	Por razones de seguridad, la correa de muñeca ESD deberá contener un resistor en serie de 1 mega ohmio.

**DANGER**

Remove both power cords before servicing.

GEFAHR	Trennen Sie beide Netzkabel, bevor Sie Wartungsarbeiten durchführen.
DANGER	Retirez les deux cordons d'alimentation avant toute maintenance.
PELIGRO	Desconecte ambos cables de alimentación antes de realizar reparaciones.

**DANGER**

Disconnect the power cord from all power sources to completely remove power from the device.

GEFAHR	Ziehen Sie das Stromkabel aus allen Stromquellen, um sicherzustellen, dass dem Gerät kein Strom zugeführt wird.
DANGER	Débranchez le cordon d'alimentation de toutes les sources d'alimentation pour couper complètement l'alimentation du dispositif.
PELIGRO	Para desconectar completamente la corriente del instrumento, desconecte el cordón de corriente de todas las fuentes de corriente.

**DANGER**

If the installation requires a different power cord than the one supplied with the device, make sure you use a power cord displaying the mark of the safety agency that defines the regulations for power cords in your country. The mark is your assurance that the power cord can be used safely with the device.

GEFAHR	Falls für die Installation ein anderes Stromkabel erforderlich ist (wenn das mit dem Gerät gelieferte Kabel nicht passt), müssen Sie sicherstellen, dass Sie ein Stromkabel mit dem Siegel einer Sicherheitsbehörde verwenden, die für die Zertifizierung von Stromkabeln in Ihrem Land zuständig ist. Das Siegel ist Ihre Garantie, dass das Stromkabel sicher mit Ihrem Gerät verwendet werden kann.
DANGER	Si l'installation nécessite un cordon d'alimentation autre que celui fourni avec le dispositif, assurez-vous d'utiliser un cordon d'alimentation portant la marque de l'organisation responsable de la sécurité qui définit les normes et réglementations pour les cordons d'alimentation dans votre pays. Cette marque vous assure que vous pouvez utiliser le cordon d'alimentation avec le dispositif en toute sécurité.
PELIGRO	Si la instalación requiere un cordón de corriente distinto al que se ha suministrado con el instrumento, verifique que usa un cordón de corriente que venga con la marca de la agencia de seguridad que defina las regulaciones para cordones de corriente en su país. Esta marca será su garantía de que el cordón de corriente puede ser utilizado con seguridad con el instrumento.

Dangers Related to Equipment Weight**DANGER**

Use safe lifting practices when moving the product.

GEFAHR	Beim Bewegen des Produktes ist auf eine sichere Hubtechnik zu achten.
DANGER	Utiliser des techniques de levage sûres pour déplacer le produit.
PELIGRO	Tenga mucho cuidado al levantar el producto para moverlo

**DANGER**

A fully populated chassis (eight FC16-64 port cards, 512 ports) weighs approximately 104.3 kg (230 lbs) and requires a hydraulic or assisted lift to install it.

GEFAHR	Ein vollständig bestücktes Gerät (acht FC16-64-Port-Karten, 512 Ports) wiegt etwa 104.3 kg und erfordert zur Installation eine hydraulische oder Servo-Hebevorrichtung.
DANGER	Un commutateur complet (huit cartes de port FC16-64, 512 ports) pèse environ 104.3 kg et requiert un dispositif de levage hydraulique ou électrique pour l'installation.
PELIGRO	Un chasis con la configuración completa (ocho tarjetas para puertos FC16-64, 512 puertos) pesa aproximadamente 161.2 kg (355 libras) y requiere un elevador hidráulico o asistido para realizar su instalación.

Laser Dangers**DANGER**

Use only optical transceivers that are qualified by Broadcom and comply with the FDA Class 1 radiation performance requirements defined in 21 CFR Subchapter I, and with IEC 60825 and EN60825. Optical products that do not comply with these standards might emit light that is hazardous to the eyes.

GEFAHR	Verwenden Sie nur optische Transceiver, die von Broadcom zugelassen sind und die die Anforderungen gemäß FDA Class 1 Radiation Performance Standards in 21 CFR, Unterkapitel I, sowie IEC 60825 und EN60825 erfüllen. Optische Produkte, die diese Normen nicht erfüllen, können Strahlen aussenden, die für das menschliche Auge gefährlich sind.
DANGER	Utilisez uniquement des émetteurs-récepteurs optiques certifiés par Broadcom et conformes aux exigences sur la puissance de rayonnement de catégorie 1 de la FDA définies au sous-chapitre 21 CFR I et à les normes IEC 60825 et EN60825. Les produits optiques non-conformes à ces normes sont susceptibles d'émettre une lumière dangereuse pour les yeux.
PELIGRO	Utilice sólo transceptores ópticos aprobados por Broadcom y que cumplan con las normas IEC 60825 y EN60825, y con los estándares de rendimiento Clase 1 de FDA definidos en el subcapítulo I de 21 CFR. Los productos ópticos que no cumplan con estos estándares pueden emitir luz dañina para los ojos.

Revision History

53-1002180-19; 2 June 2020

The following change has been made:

- Removed the "Brocade DCX 8510 Technical Specifications" section from this guide. The technical specifications are provided in a separate guide.

