

USER'S GUIDE

Ultra320 SCSI Host Adapters

September 2006

Version 2.3



Electromagnetic Compatibility Notices

This device complies with Part 15 of the FCC Rules. Operation is subject to the following two conditions:

1. This device may not cause harmful interference, and
2. This device must accept any interference received, including interference that may cause undesired operation.

This equipment has been tested and found to comply with the limits for a Class B digital device, pursuant to part 15 of the FCC Rules. These limits are designed to provide reasonable protection against harmful interference in a residential installation. This equipment generates, uses, and can radiate radio frequency energy and, if not installed and used in accordance with the instructions, may cause harmful interference to radio communications. However, there is no guarantee that interference will not occur in a particular installation. If this equipment does cause harmful interference to radio or television reception, which can be determined by turning the equipment off and on, the user is encouraged to try to correct the interference by one or more of the following measures:

- Reorient or relocate the receiving antenna.
- Increase the separation between the equipment and the receiver.
- Connect the equipment into an outlet on a circuit different from that to which the receiver is connected.
- Consult the dealer or an experienced radio/TV technician for help.

Shielded cables for SCSI connection external to the cabinet are used in the compliance testing of this Product. LSI Logic is not responsible for any radio or television interference caused by unauthorized modification of this equipment or the substitution or attachment of connecting cables and equipment other than those specified by LSI Logic. The correction of interferences caused by such unauthorized modification, substitution, or attachment will be the responsibility of the user.

The LSI Logic Ultra320 SCSI to PCI Host Adapters (LSI20320, LSI20320-R, LSI20320L-R, LSIU320, LSIU320-R, LSI20320A, LSI20320A-R, LSI20320IE, LSI20320ILE, LSI21320, LSI21320-R, LSI22320, LSI22320-R, LSI22320T, LSI22320SE, LSI22320SLE) are tested to comply with FCC standards for home or office use.

This Class B digital apparatus meets all requirements of the Canadian Interference-Causing Equipment Regulations.

Cet appareil numérique de la classe B respecte toutes les exigences du Règlement sur le matériel brouilleur du Canada.

この装置は、情報処理装置等電波障害自主規制協議会（VCCI）の基準に基づくクラスB情報技術装置です。この装置は、家庭環境で使用することを目的としていますが、この装置がラジオやテレビジョン受信機に近接して使用されると、受信障害を引き起こすことがあります。
取扱説明書に従って正しい取り扱いをして下さい。

This is a Class B product based on the standard of the Voluntary Control Council for Interference from Information Technology Equipment (VCCI). If this is used near a radio or television receiver in a domestic environment, it may cause radio interference. Install and use the equipment according to the instruction manual.



LSI Logic Asia, Inc. Taiwan Branch
10/F, 156, Min Sheng E. Rd., Section 3,
Taipei, Taiwan, R.O.C.
Tel: 886.2.2718.7828
FAX: 886.2.2718.8869

LSI Logic Corporation
North American Headquarters
Milpitas, CA
Tel: 408.433.8000

This document contains proprietary information of LSI Logic Corporation. The information contained herein is not to be used by or disclosed to third parties without the express written permission of an officer of LSI Logic Corporation.

LSI Logic products are not intended for use in life-support appliances, devices, or systems. Use of any LSI Logic product in such applications without written consent of the appropriate LSI Logic officer is prohibited.

Document DB15-000192-04, Version 2.3 (September 2006)

This document describes the LSI Logic Corporation Ultra320 SCSI Host Adapters and will remain the official reference source for all revisions/releases of this product until rescinded by an update.

LSI Logic Corporation reserves the right to make changes to any products herein at any time without notice. LSI Logic does not assume any responsibility or liability arising out of the application or use of any product described herein, except as expressly agreed to in writing by LSI Logic; nor does the purchase or use of a product from LSI Logic convey a license under any patent rights, copyrights, trademark rights, or any other of the intellectual property rights of LSI Logic or third parties.

Copyright © 2002–2004, 2006 by LSI Logic Corporation. All rights reserved.

TRADEMARK ACKNOWLEDGMENT

LSI Logic, the LSI Logic logo design, Fusion-MPT, Integrated Mirroring, Integrated RAID, Integrated Striping, and SureLINK are trademarks or registered trademarks of LSI Logic Corporation. Windows and Windows NT are registered trademarks of Microsoft Corporation. All other brand and product names may be trademarks of their respective companies.

SR

To receive product literature, visit us at <http://www.lsillogic.com>.

For a current list of our distributors, sales offices, and design resource centers, view our web page located at

<http://www.lsillogic.com/contacts/index.html>

Preface

This document is the user's guide for all LSI Logic Ultra320 SCSI Host Adapters. It contains a functional description of the Ultra320 SCSI host adapters as well as physical and electrical specifications. It also contains instructions for installing the host adapters and for connecting SCSI devices to them.

Audience

This document assumes that you have some familiarity with SCSI protocol and related support devices. This document benefits people installing and using the various Ultra320 SCSI host adapters.

Organization

This document has the following chapters and appendix:

- [Chapter 1, Quick Installation Procedures](#), provides quick instructions for installing your Ultra320 SCSI host adapter and Windows device drivers.
- [Chapter 2, Detailed Host Adapter Installation](#), provides detailed instructions for installing your Ultra320 SCSI host adapter.
- [Chapter 3, Ultra320 SCSI Host Adapter Characteristics](#), illustrates the various Ultra320 SCSI host adapters and provides PCI and SCSI interface information.
- [Appendix A, Glossary of Terms](#), provides definitions of terms used in this book.

Related Publications

The PCI/PCI-X/PCI Express interfaces are compatible with the *PCI Local Bus Specification, Revision 2.2*, *PCI-X Addendum to the PCI Local Bus Specification, Revision 1.0a*, and *PCI Express Bridge Specification, Revision 1.0*. The SCSI interface is compatible with the ANSI draft standard X3T10.11/1142.

LSI53C1020/1020A PCI-X to Ultra320 SCSI Controller Technical Manual, Document No. DB14-000176-06

LSI53C1030 PCI-X to Dual Channel Ultra320 SCSI Multifunction Controller Technical Manual, Document No. DB14-000156-05

Fusion-MPT™ Device Management User's Guide, Document No. DB15-000186-01

Integrated RAID™ User's Guide, Document No. DB15-000292-00

Revision History

Document Number	Version/Date	Remarks
DB15-000192-04	Version 2.3 September 2006	Added the following host adapters: LSI20320IE, LSI20320ILE, LSI22320SE, and LSI22320SLE. Deleted LSI22320E and LSI22320E-R.
DB15-000192-03	Version 2.2 April 2004	Added the following host adapters: LSIU320, LSIU320-R, LSI20320A, LSI20320A-R, LSI20320L-R, LSI22320T, LSI22320E and LSI22320E-R. Added information about Integrated RAID (IR). Deleted the LSI20320H host adapter.
DB15-000192-01	Version 2.1 July 2003	Corrected glossary entries for Ultra160 and Ultra320. Other minor editing also. In Section 3.3.2, corrected storage temp range to -40 °C to 105 °C.
DB15-000192-00	Version 2.0 May 2002	Final version.

Contents

Chapter 1

Quick Installation Procedures

1.1	General Description	1-1
1.2	Quick Host Adapter Installation	1-2
1.3	Quick Windows Driver Installation	1-4

Chapter 2

Detailed Host Adapter Installation

2.1	Installing Your Ultra320 SCSI Host Adapter	2-1
2.1.1	Selecting a PCI Slot	2-1
2.1.2	Inserting the Host Adapter	2-3
2.2	SCSI Device Cables	2-4
2.2.1	Internal SCSI Cables	2-4
2.2.2	External SCSI Cable	2-5
2.3	Connecting SCSI Devices	2-6
2.3.1	Connecting Internal SCSI Devices	2-6
2.3.2	Connecting the LED Cable	2-8
2.3.3	Connecting External SCSI Devices	2-9
2.4	Terminating the SCSI Bus	2-11
2.5	Setting SCSI IDs	2-12
2.6	Completing the Installation	2-13
2.7	Setting Up Integrated RAID (IR) Solution	2-13
2.7.1	Integrated Mirroring Solution	2-14
2.7.2	Integrated Striping Solution	2-14

Chapter 3

Ultra320 SCSI Host Adapter Characteristics

3.1	Ultra320 SCSI Host Adapters	3-1
3.1.1	LSI20320 Single Channel Host Adapters	3-2
3.1.2	LSIU320 and LSI20320A Single Channel Host Adapters	3-4
3.1.3	LSI20320IE and LSI20320ILE Single Channel Host Adapters	3-6
3.1.4	LSI21320 Dual Channel Host Adapters	3-8
3.1.5	LSI22320 Dual Channel Host Adapters	3-10
3.1.6	LSI22320SE and LSI22320SLE Dual Channel Host Adapters	3-12
3.2	Host Adapter Characteristics	3-14
3.3	Technical Specifications	3-14
3.3.1	Electrical Characteristics	3-14
3.3.2	Thermal and Atmospheric Characteristics	3-15
3.3.3	Safety Characteristics	3-16

Appendix A

Glossary of Terms

Customer Feedback

Figures

2.1	Hardware Connections for the Host Adapter	2-2
2.2	Inserting the Host Adapter	2-3
2.3	SCSI Cable – 68-Pin High Density with Terminator	2-4
2.4	SCSI Cable – 68-Pin High Density without Terminator	2-4
2.5	SCSI Cable – 68-Pin VHDCI to 68-Pin VHDCI	2-5
2.6	SCSI Cable – 68-Pin VHDCI to 68-Pin HD	2-5
2.7	SCSI Cable – 68-Pin HD to 68-Pin HD	2-5
2.8	Connecting Internal SCSI Cable to Host Adapter	2-6
2.9	Connecting Multiple Internal SCSI Devices	2-7
2.10	SCSI LED Connector	2-8
2.11	Connecting One External SCSI Device	2-9
2.12	Connecting Multiple External SCSI Devices	2-10
3.1	LSI20320, LSI20320-R, and LSI20320L-R Host Adapter Drawing	3-3
3.2	LSIU320, LSIU320-R, LSI20320A, and LSI20320A-R Host Adapter Drawing	3-5
3.3	LSI20320IE and LSI21320ILE Host Adapter Drawing	3-7
3.4	LSI21320 and LSI21320-R Host Adapter Drawing	3-9
3.5	LSI22320 and LSI22320-R Host Adapter Drawing	3-11
3.6	LSI22320T Host Adapter Drawing	3-11
3.7	LSI22320SE and LSI22320SLE Host Adapter Drawing	3-13

Tables

1.1	Ultra320 SCSI Controllers and Host Adapters	1-1
2.1	SCSI ID Record for Dual Channel Host Adapter	2-12
2.2	Host Adapter Installation Checklist	2-13
3.1	Ultra320 SCSI to PCI/PCI-X or PCI Express x4 Host Adapters	3-1
3.2	Host Adapter Characteristics	3-14
3.3	Maximum Power Requirements	3-15

Chapter 1

Quick Installation Procedures

This chapter contains general information about Ultra320 SCSI controllers and host adapters. It provides quick host adapter installation instructions and SCSI bus setup for *experienced computer users*. It also provides quick installation instructions for Windows device drivers. This chapter includes these topics:

- [Section 1.1, “General Description”](#)
- [Section 1.2, “Quick Host Adapter Installation”](#)
- [Section 1.3, “Quick Windows Driver Installation”](#)

1.1 General Description

LSI Logic provides high-performance, cost-effective Ultra320 SCSI controllers and host adapters. [Table 1.1](#) shows the LSI controllers and their associated host adapters that support Ultra320 SCSI. For specific information about the Ultra320 SCSI controllers, refer to the [Related Publications](#) section on [page vi](#) in the Preface. Letters at the end of an adapter name indicates a feature such as: A = low cost; E = PCI Express; L = low profile; R = Integrated RAID™ solution; and T = target mode.

Table 1.1 Ultra320 SCSI Controllers and Host Adapters

Controllers	Host Adapters
LSI53C1020	LSI20320, LSI20320-R, LSI20320L-R
LSI53C1020A	LSIU320, LSIU320-R, LSI20320A, LSI20320A-R LSI20320IE, LSI20320ILE
LSI53C1030	LSI21320, LSI21320-R, LSI22320, LSI22320-R, LSI22320SE, LSI22320SLE
LSI53C1030T	LSI22320T

Installing any of these host adapters in your PCI/PCI-X/PCI Express system allows you to connect up to 15 SCSI devices per channel over a SCSI bus. The LSI20320L-R, LSI20320ILE and LSI22320SLE are designed with a bracket that is suitable for low profile applications.

To achieve Ultra320 SCSI performance, you must connect only Low Voltage Differential (LVD) devices to the host adapter. If you connect single-ended (SE) devices and LVD devices, the entire bus drops to the lower SE speed, limiting bus performance to Ultra SCSI.

The Ultra320 SCSI host adapters support all major operating systems (OS), such as Windows (NT 4.0, 2000, 2003, and XP), Linux, NetWare, UnixWare, SCO OpenServer 5.x, and Solaris SPARC. Other software support includes SureLINK™ Domain Validation, which ensures data integrity by intelligently testing the SCSI interconnect before completing negotiation.

The Ultra320 SCSI host adapters utilize Fusion-MPT™ architecture for all major operating systems, which allows for thinner drivers and better performance. To obtain a device driver that supports your operating system, contact the LSI technical support team at 800-633-4545 or visit the LSI web site at <http://www.lsillogic.com>.

1.2 Quick Host Adapter Installation

Use these quick installation steps if you have installed computer add-in boards before and connected devices to them. For more detailed instructions and guidance, refer to [Section 2.1, “Installing Your Ultra320 SCSI Host Adapter,” on page 2-1](#).

To install an Ultra320 SCSI host adapter, follow these steps:

Step 1. Turn off and unplug the computer.

Warning: Be sure to disconnect the computer's power before you remove the cover and install the Ultra320 SCSI host adapter. Failure to do so may result in exposure to shock, electrical hazards, and/or mechanical hazards.

Step 2. Open your computer cabinet by removing its cover.

- Step 3. Be sure to touch a grounded metal surface to discharge static electricity before handling the host adapter.
- Step 4. Remove the host adapter from its packaging and examine it for any damage.
- Step 5. Locate an unused PCI/PCI-X/PCI Express slot.
- Step 6. Insert your SCSI host adapter into the selected slot.
- Step 7. Connect the internal and external SCSI devices to connectors on one SCSI channel.
- Step 8. Install SCSI bus terminators at the ends of the SCSI bus.
The SCSI bus must be properly terminated.
- Step 9. Set the SCSI IDs for all devices and record them for future reference.
- Step 10. Make any configuration changes.
- Step 11. Before replacing the cover on your computer, verify your installation:
 - Is the host adapter connection in the PCI/PCI-X/PCI Express bus slot secure?
 - Are the internal SCSI bus connections secure?
 - Are the external SCSI bus connections secure?
 - Is the SCSI bus terminated correctly?
 - Have the SCSI IDs been set and recorded for each device?
- Step 12. Replace the cabinet cover on your computer.
- Step 13. Plug in all power cords and turn on power to all devices and your computer.
- Step 14. Wait for your computer to start up.

The host adapter installation is complete.

1.3 Quick Windows Driver Installation

To load the `SYMMPTI.SYS` miniport driver during a new Windows NT, Windows 2000, Windows XP, or Windows .NET system installation, you can boot directly from the Microsoft installation CD-ROM. The Windows drivers are not interchangeable; however, the instructions are very similar.

To install a new Windows operating system and its appropriate device driver, follow these steps:

- Step 1. Have the Microsoft Windows driver diskette available to insert into drive A when prompted.
- Step 2. Boot the computer from the Microsoft Windows CD-ROM.
- Step 3. Press F6 when the words `Setup is inspecting your computer's hardware configuration appear`, or when Windows prompts you for nonsupported drivers.

Important: You must press F6 for the new driver to be recognized. Otherwise, the system does not recognize the devices controlled by the driver during the Windows setup.

- Step 4. Follow the instructions until a screen displaying the words `Setup could not determine the type of one or more mass storage device... appear`.
- Step 5. Choose S to Specify Additional Devices.
- Step 6. Follow the prompts and insert the Windows driver diskette when prompted.
- Step 7. Follow the Microsoft Windows installation procedure to complete the installation. Microsoft provides documentation with its installation CD-ROM.
- Step 8. If you are installing Windows NT 4.0, also install the Service Packs 5 or higher after Windows NT 4.0 has been installed.

Note: Refer to the *Fusion-MPT Device Management User's Guide* for detailed configuration and installation instructions for all firmware and drivers.

Chapter 2

Detailed Host Adapter Installation

This chapter provides detailed instructions on how to install the LSI Ultra320 SCSI host adapters and includes these topics:

- [Section 2.1, “Installing Your Ultra320 SCSI Host Adapter”](#)
 - [Section 2.2, “SCSI Device Cables”](#)
 - [Section 2.3, “Connecting SCSI Devices”](#)
 - [Section 2.4, “Terminating the SCSI Bus”](#)
 - [Section 2.5, “Setting SCSI IDs”](#)
 - [Section 2.6, “Completing the Installation”](#)
 - [Section 2.7, “Setting Up Integrated RAID \(IR\) Solution”](#)
-

2.1 Installing Your Ultra320 SCSI Host Adapter

This section provides detailed instructions for installing your Ultra320 SCSI host adapter and connecting your SCSI devices to it. The following illustrations show the LSI22320-R Dual Channel Ultra320 SCSI host adapter. However, these illustrations apply to all host adapters. For details on all the Ultra320 SCSI host adapters, refer to [Chapter 3, “Ultra320 SCSI Host Adapter Characteristics.”](#)

2.1.1 Selecting a PCI Slot

Follow these steps to locate a PCI slot.

Step 1. Turn off and unplug your computer.

Warning: Be sure to disconnect the computer’s power before you remove the cover and install the Ultra320 SCSI host adapter.

Step 2. Open your computer cabinet by removing its cover.

Step 3. Be sure to touch a grounded metal surface to discharge static electricity before removing the host adapter from its package.

Caution: You must touch a grounded metal surface before handling the host adapter because static charges on your body can damage electronic components. Handle plug-in boards by the edge; do not touch board components or gold connector contacts. LSI recommends that you use a static ground strap.

Step 4. Remove your Ultra320 SCSI host adapter from its packaging and verify that it is not damaged.

Figure 2.1 illustrates the LSI22320 series host adapter and Figure 2.2 illustrates the LSI22320IE and LSI22320SE host adapters.

Figure 2.1 Hardware Connections for the Host Adapter

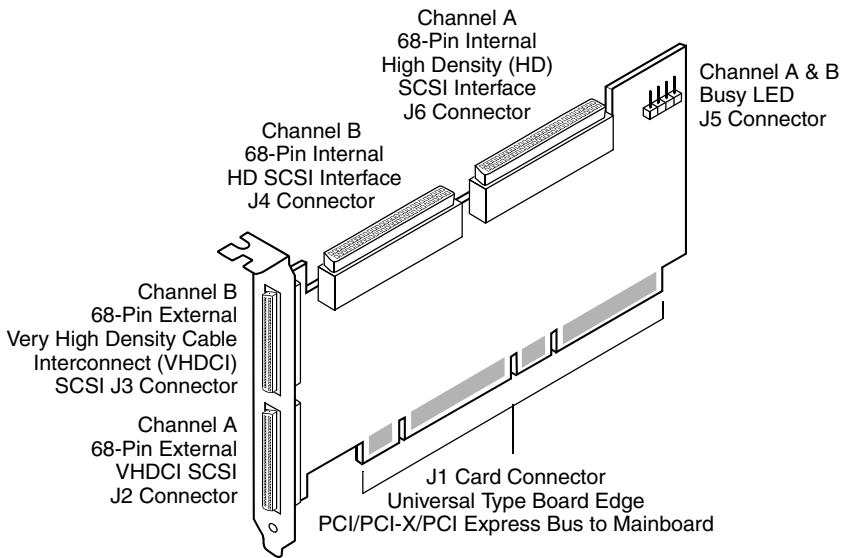

Step 5. Find an unused PCI/PCI-X/PCI Express slot.

Note: You can insert a 64-bit host adapter into a 32-bit slot if no 64-bit slots are available. However, this limits the data transmission rate to 32-bit transfers.

2.1.2 Inserting the Host Adapter

Follow these steps to install your Ultra320 SCSI host adapter in the PC mainboard.

Step 1. Remove the blank bracket panel on the back of the computer that is aligned with the PCI/PCI-X/PCI Express slot you have selected.
Save the bracket screw.

Step 2. Carefully insert the edge connector into the PCI Express slot.

Caution: Apply even pressure to both top corners of the board while inserting it, as shown in [Figure 2.2](#).

Caution: Do *not* apply pressure to the center of the board, or to any add-on cards that are connected to the host bus adapter.

Figure 2.2 Inserting the Host Adapter

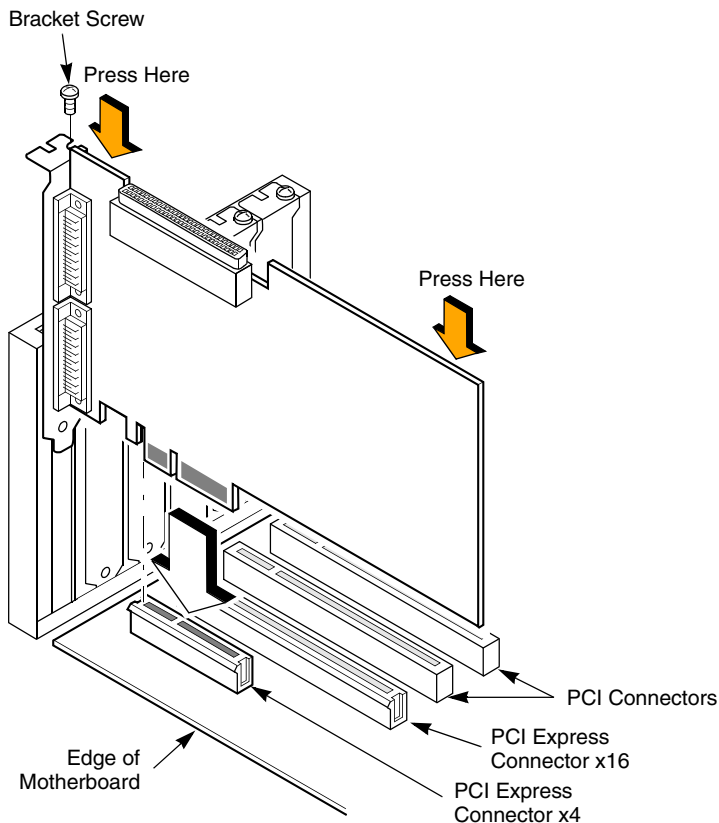

- Step 3. Make sure the edge connector is properly aligned before pressing the adapter into place. The bracket should fit into the empty space where the blank bracket panel was removed.
- Step 4. Be sure to tighten the bracket screw into the bracket securely before you connect the internal and external SCSI devices.

2.2 SCSI Device Cables

For reliable Ultra320 operation, be sure to use an Ultra320-rated SCSI device cable. The internal Ultra320 SCSI device cable also has built-in low voltage differential (LVD) and single-ended termination. This built-in feature is included because most LVD SCSI hard disk drives are not made with on-board low voltage differential termination.

2.2.1 Internal SCSI Cables

You can connect all internal SCSI devices to the host adapter with an unshielded, twisted pair, 68-pin ribbon cable. Some 68-pin internal SCSI cables come with a low voltage differential and single-ended terminator on one end, which must be farthest from the host adapter. [Figure 2.3](#) and [Figure 2.4](#) show internal SCSI cables with and without a terminator.

Figure 2.3 SCSI Cable – 68-Pin High Density with Terminator

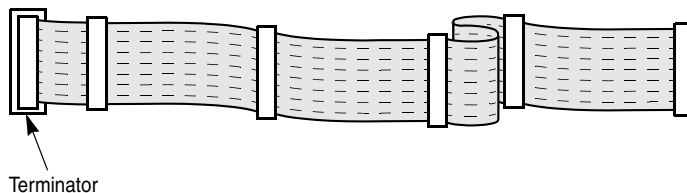
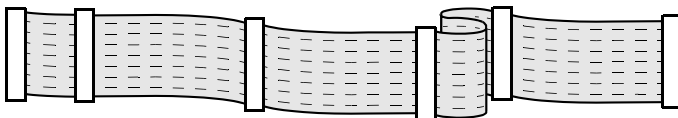

Figure 2.4 SCSI Cable – 68-Pin High Density without Terminator



2.2.2 External SCSI Cable

You must connect all external SCSI devices to the host adapter with shielded cables. Figures 2.5 to 2.7 are examples of external SCSI cables. Select the correct 68-pin cable for your devices.

Figure 2.5 SCSI Cable – 68-Pin VHDCI to 68-Pin VHDCI

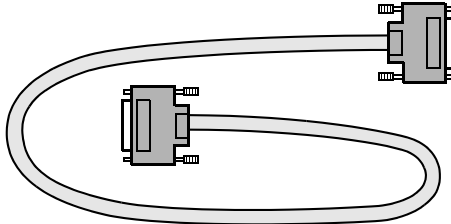

Figure 2.6 SCSI Cable – 68-Pin VHDCI to 68-Pin HD

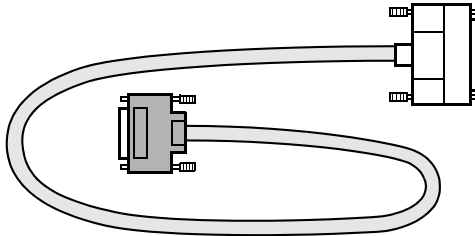
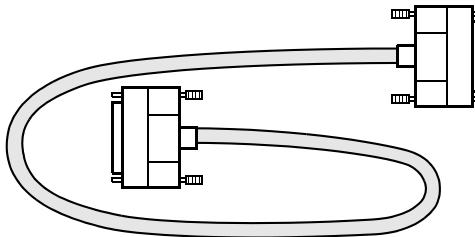

Figure 2.7 SCSI Cable – 68-Pin HD to 68-Pin HD



2.3 Connecting SCSI Devices

This section explains how to connect internal and external SCSI devices to the Ultra320 SCSI host adapters.

2.3.1 Connecting Internal SCSI Devices

This subsection provides step-by-step instructions for connecting internal SCSI devices. The figures show the LSI22320 host adapter, which has two internal connectors and two external connectors. Other Ultra320 SCSI host adapter models have different numbers of connectors. Refer to [Section 2.2.1, “Internal SCSI Cables,” on page 2-4](#) for examples of internal cables. Follow these steps for making connections:

- Step 1. Plug the 68-pin connector on the end of the SCSI ribbon cable into the internal connector on the host adapter, as [Figure 2.8](#) shows.

Figure 2.8 Connecting Internal SCSI Cable to Host Adapter

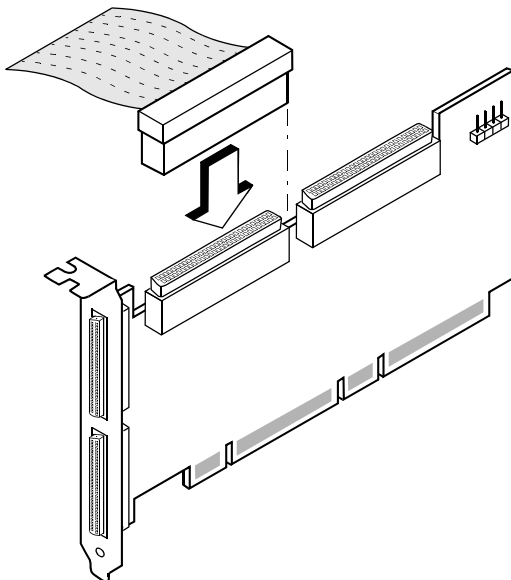

- Step 2. Plug the 68-pin connector on the other end of the internal SCSI ribbon cable into the SCSI connector on the internal SCSI device, as [Figure 2.9](#) shows.

Figure 2.9 Connecting Multiple Internal SCSI Devices

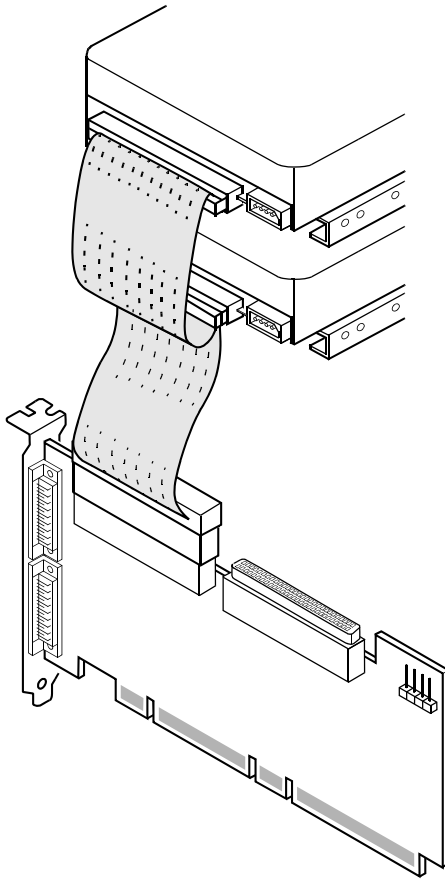

- Step 3. If you have another internal SCSI device, connect the internal SCSI ribbon cable to it, as [Figure 2.9](#) shows. You can connect other devices if the cable has more connectors. The Ultra320 SCSI host adapters support up to 15 SCSI devices connected to each SCSI channel.
- Step 4. Be sure that termination is enabled at the end of the cable that is farthest away from the SCSI host adapter. Refer to [Section 2.4, "Terminating the SCSI Bus,"](#) on page 2-11 for details on SCSI bus termination.

2.3.2 Connecting the LED Cable

Most computer cabinets have a front panel LED. When properly connected, the front panel LED lights up when there is activity on the SCSI bus.

Connect the LED cable to connector J5 on the host adapter, as [Figure 2.10](#) shows. Connector J5 is not keyed.

Figure 2.10 SCSI LED Connector

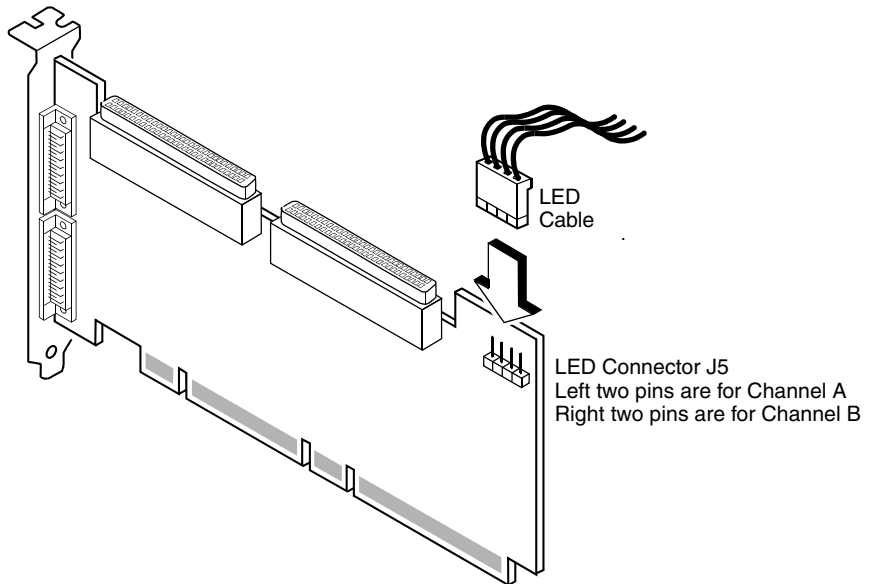

The orientation of the LED cable does not matter as long as all four pins are connected. If the LED does not light up during SCSI bus activity from this host adapter, you may have to rotate the LED cable connector 180 degrees on J5.

If the LED cable has only two wires, place the connector on one end or the other of J5. If the LED does not light up when there is SCSI activity, move the connector to the other half of J5.

2.3.3 Connecting External SCSI Devices

This section provides step-by-step instructions for connecting external SCSI devices. Refer to [Section 2.2.2, “External SCSI Cable,”](#) on page 2-5 for examples of external cables.

- Step 1. Plug the 68-pin connector on one end of a shielded external SCSI cable into the host adapter’s external SCSI connector. This connector is exposed on the back panel of your computer.
- Step 2. Plug the 68-pin connector on the other end of the shielded external SCSI cable into the SCSI connector on the first external SCSI device.

[Figure 2.11](#) shows how to connect a single external SCSI device. If you have the correct cable, it matches the external connector.

Figure 2.11 Connecting One External SCSI Device

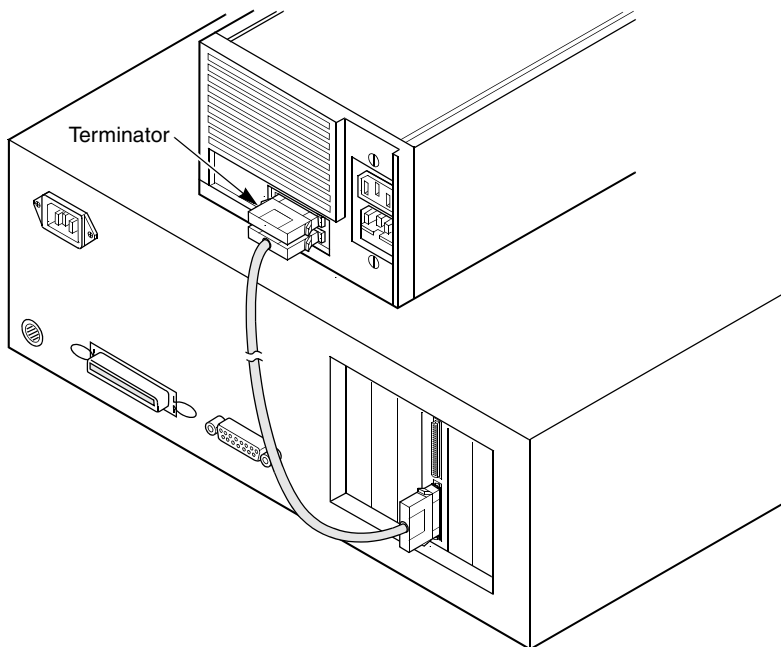

Step 3. Connect any additional SCSI devices to one another with shielded external SCSI cables. You need a separate SCSI cable for each additional device.

Figure 2.12 shows how to connect multiple external SCSI devices.

Figure 2.12 Connecting Multiple External SCSI Devices

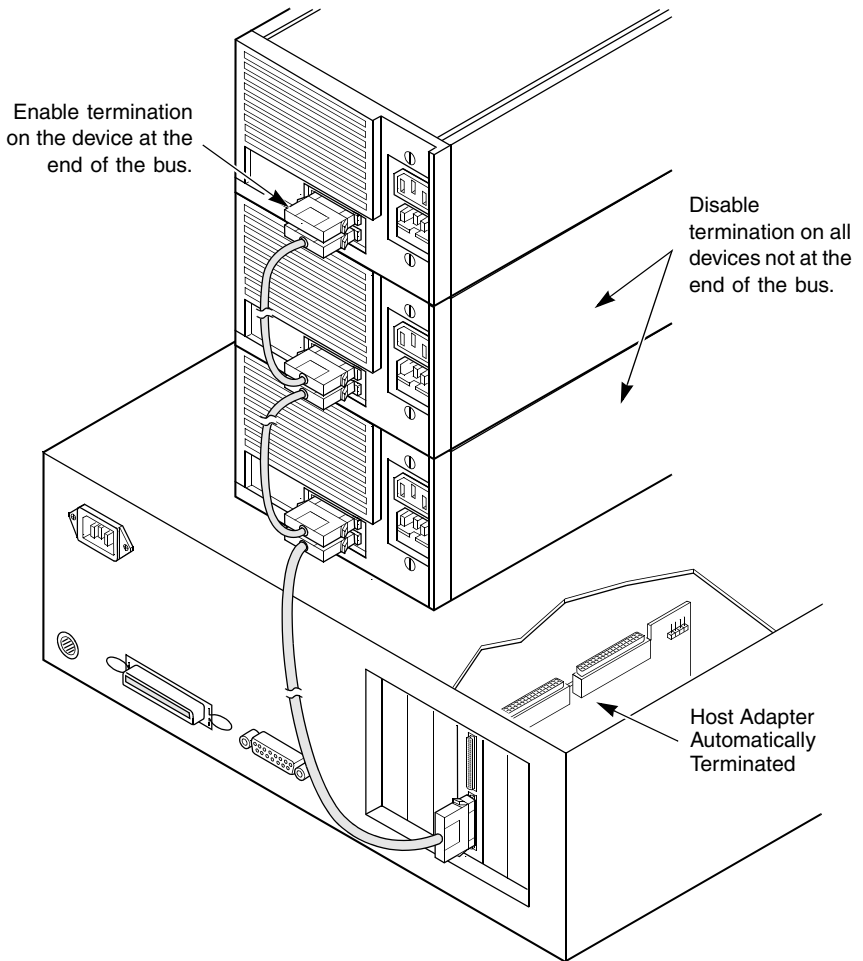

Step 4. Be sure that termination is enabled *only* on the last external SCSI device, as Figure 2.12 shows. Refer to Section 2.4, “Terminating the SCSI Bus,” on page 2-11 for details on SCSI bus termination.

2.4 Terminating the SCSI Bus

The SCSI bus contains all the devices that you connect with SCSI cables. When you connect the first and last physical SCSI devices on the ends of the SCSI bus, you must have termination active. You must remove or disable termination on all other SCSI devices on the same bus.

If you connect only internal SCSI devices on a bus, the host adapter automatically terminates itself. If you connect only external SCSI devices on a bus, the host adapter also terminates automatically. Automatic termination occurs because the host adapter connection is at the *end* of the SCSI bus. If you connect both internal and external SCSI devices on a bus, the host adapter automatically disables its termination. This occurs because the host adapter is in the *middle* of the SCSI bus. Termination for host adapters with only one connector per channel is always enabled for the channel.

2.5 Setting SCSI IDs

SCSI IDs identify each SCSI device on the SCSI bus. Each SCSI ID on a given bus must be unique. The IDs are 0–15 for a 16-bit bus. The preset host adapter ID setting is 7, which gives the highest priority to the host adapter.

Typically, you set the SCSI ID of the SCSI device with jumpers or with a switch on the device. You must not duplicate SCSI IDs on a SCSI bus. LSI recommends that you record the SCSI IDs of all SCSI devices. [Table 2.1](#) provides a place to keep this record.

Table 2.1 SCSI ID Record for Dual Channel Host Adapter

SCSI ID	SCSI Device Channel A	SCSI Device Channel B
15		
14		
13		
12		
11		
10		
9		
8		
7	Ultra320 SCSI host adapter	Ultra320 SCSI host adapter
6		
5		
4		
3		
2		
1		
0		

2.6 Completing the Installation

Before replacing the cover on your computer, complete the checklist as shown in [Table 2.2](#).

Table 2.2 Host Adapter Installation Checklist

Verify Installation Procedures	Done
Host adapter connection in PCI/PCI-X/PCI Express bus slot is secure (level)	
Internal SCSI bus connections are secure (pin-1 continuity)	
External SCSI bus connections are secure	
Proper SCSI bus termination established	
Unique SCSI IDs set and recorded for each device	

After you verify all items on the checklist, follow these steps:

- Step 1. Replace the cabinet cover on your computer.
- Step 2. Plug in all power cords, and turn on power to all devices and your computer.
- Step 3. Wait for your computer to boot up.

Note: To change default configurations of the Ultra320 SCSI host adapters, refer to the *Fusion-MPT Device Management System User's Guide*.

2.7 Setting Up Integrated RAID (IR) Solution

The “R” at the end of a host adapter name indicates the board supports the Integrated RAID solution. The Integrated RAID solution provides cost benefits for the server or workstation market where the extra performance, storage capacity, and/or redundancy of a RAID configuration are required. The two components of the Integrated RAID solution are:

- **Integrated Mirroring™ (IM)** solution, which provides features of RAID 1 and RAID 1E
- **Integrated Striping™ (IS)** solution, which provides features of RAID 0

By simplifying the IM and IS options and by providing firmware support in its host adapters, LSI can offer the Integrated RAID solution at a lower cost than a dedicated processor based RAID implementation.

The Fusion-MPT Common Information Model (CIM) interface software continuously monitors IM volumes and IS volumes, and reports status and error conditions as they arise.

IM and IS are supported by different versions of the Fusion-MPT firmware. Therefore, either IM or IS can be implemented on a system with a Fusion-MPT firmware based host adapter, but IM and IS cannot be used concurrently on the same system.

The Fusion-MPT BIOS Configuration Utility (CU) configures the IM or IS volume, which can use from two to six disk drives. The BIOS and drivers support SCSI Domain Validation. Host-based CIM software monitors the state of the physical disks and reports error conditions as they arise.

2.7.1 Integrated Mirroring Solution

As a result of the shift toward Network Attached Storage (NAS), ISPs need a cost-effective, fault-tolerant solution to protect the operating systems on small form factor, high-density, rack-mountable servers. The IM solution provides data protection for the system boot volume to safeguard critical information such as the OS on servers and high performance workstations. This new Integrated Mirroring solution gives customers a robust, high-performance, fault-tolerant solution that is less expensive than a dedicated RAID controller.

2.7.2 Integrated Striping Solution

The IS solution is targeted at applications that require the faster performance and increased storage capacity of striping. The IS solution is a low-cost solution with many of the features of a more expensive RAID striping solution. A single IS logical drive may be configured as the boot disk or as a data disk.

To set up the Integrated RAID (IM and IS) features, refer to the *Integrated RAID User's Guide*.

Chapter 3

Ultra320 SCSI

Host Adapter

Characteristics

This chapter describes the LSI Ultra320 SCSI host adapters. This chapter includes these topics:

- [Section 3.1, “Ultra320 SCSI Host Adapters”](#)
- [Section 3.2, “Host Adapter Characteristics”](#)
- [Section 3.3, “Technical Specifications”](#)

3.1 Ultra320 SCSI Host Adapters

PCI, PCI-X and PCI Express are high-speed standard local buses for interfacing a number of I/O components to the processor and memory subsystems in a high-end PC. [Table 3.1](#) lists the Ultra320 SCSI to PCI/PCI-X or PCI Express x4 host adapters.

Table 3.1 Ultra320 SCSI to PCI/PCI-X or PCI Express x4 Host Adapters

Adapter	SCSI Channel	IR Support	Bracket	Board Dimensions
LSI20320	Single Channel	–	Standard	6.6 x 2.53 inches, 167.6 x 64.3 mm
LSI20320-R	Single Channel	IR support	Standard	6.6 x 2.53 inches, 167.6 x 64.3 mm
LSI20320L-R	Single Channel	IR support	Low Profile	6.6 x 2.53 inches, 167.6 x 64.3 mm
LSI20320A	Single Channel	–	Standard	6.6 x 3.27 inches, 167.6 x 83.1 mm
LSI20320A-R	Single Channel	IR support	Standard	6.6 x 3.27 inches, 167.6 x 83.1 mm
LSI20320IE	Single Channel	–	Standard	6.6 x 2.71 inches, 167.6 x 66.2 mm
LSI20320ILE	Single Channel	–	Low Profile	6.6 x 2.71 inches, 167.6 x 66.2 mm
LSIU320	Single Channel	–	Standard	6.6 x 3.27 inches, 167.6 x 83.1 mm
LSIU320-R	Single Channel	IR support	Standard	6.6 x 3.27 inches, 167.6 x 83.1 mm
LSI21320	Dual Channel	–	Standard	6.6 x 3.27 inches, 167.6 x 83.1 mm
LSI21320-R	Dual Channel	IR support	Standard	6.6 x 3.27 inches, 167.6 x 83.1 mm

Table 3.1 Ultra320 SCSI to PCI/PCI-X or PCI Express x4 Host Adapters (Cont.)

Adapter	SCSI Channel	IR Support	Bracket	Board Dimensions
LSI22320	Dual Channel	–	Standard	6.6 x 4.0 inches, 167.6 x 101.6 mm
LSI22320-R	Dual Channel	IR support	Standard	6.6 x 4.0 inches, 167.6 x 101.6 mm
LSI22320T	Dual Channel	–	Standard	6.6 x 4.0 inches, 167.6 x 101.6 mm
LSI20320SE	Dual Channel	–	Standard	6.6 x 2.71 inches, 167.6 x 66.2 mm
LSI20320SLE	Dual Channel	–	Low Profile	6.6 x 2.71 inches, 167.6 x 66.2 mm

The component height on the top and bottom of the Ultra320 SCSI host adapters follows the *PCI Local Bus Specification, Revision 2.2*, *PCI-X Addendum to the PCI Local Bus Specification, Revision 1.0a*, and *PCI Express to PCI/PCI-X Bridge Specification, Revision 1.0*. The Ultra320 SCSI host adapters are used in PCI/PCI-X and PCI Express computer systems with PCI standard and PCI low profile bracket types.

3.1.1 LSI20320 Single Channel Host Adapters

The LSI20320 series of host adapters are single channel Ultra320 SCSI host adapters that provide one Ultra320 SCSI channel. The SCSI Channel A interface is made through connectors J1 and J3.

Features of the LSI20320 series of host adapters are:

- Single Ultra320 SCSI channel
- Two SCSI connectors
 - One external 68-pin very high density cable interconnect (VHDCI) connection
 - One internal 68-pin high density (HD) connector
- PCI low profile bracket (LSI20320L-R only)
- LVD/SE termination
- Integrated RAID (IR) solution applies to the “R” cards only
- Fusion-MPT architecture

Details of the LSI20320 series of host adapters are:

- J5: PCI and PCI-X, 64-bit, universal type board edge connector
- J1: 68-pin VHDCI shielded right-angle external connector

- J3: 68-pin HD right-angle internal connector
- HDR2: 4-pin low density unshrouded right-angle LED connector
- Subsystem Vendor ID and Subsystem IDs are:

Host Adapter	Chip	Subsystem Vendor ID	Subsystem ID
LSI20320	1020	0x1000	50F0
LSI20320-R	1020	0x1000	7100
LSI20320L-R	1020	0x1000	1060

During system initialization, the system loads the ID numbers into the Subsystem Vendor ID and Subsystem ID registers of the embedded SCSI controller.

Figure 3.1 illustrates the LSI20320 series of host adapters. The LSI20320L-R adapter uses a PCI low profile bracket.

Figure 3.1 LSI20320, LSI20320-R, and LSI20320L-R Host Adapter Drawing

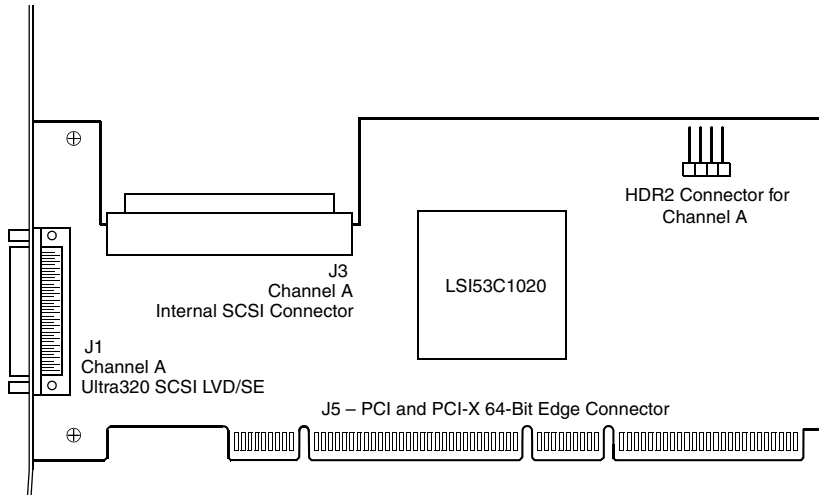

3.1.2 LSIU320 and LSI20320A Single Channel Host Adapters

The LSIU320 and LSI20320A series of host adapters are single channel Ultra320 SCSI host adapters that provide one Ultra320 SCSI channel. The SCSI Channel A interface for is made through connectors J2 and J3.

Features of the LSIU320 and LSI20320A series of host adapters are:

- Single Ultra320 SCSI channel
- Two SCSI connectors
 - One external 68-pin HD connector
 - One internal 68-pin HD connector
- LVD/SE termination
- Integrated RAID (IR) solution applies to the “R” cards only
- Fusion-MPT architecture

Details of the LSIU320 and LSI20320A series of host adapters are:

- J1: PCI and PCI-X, 64-bit, universal type board edge connector
- J2: 68-pin HD right-angle internal connector
- J3: 68-pin HD right-angle internal connector
- J4: 4-pin low density unshrouded right-angle LED connector
- Subsystem Vendor ID and Subsystem IDs are:

Host Adapter	Chip	Subsystem Vendor ID	Subsystem ID
LSIU320	1020A	0x1000	5100
LSIU320-R	1020A	0x1000	5100
LSI20320A	1020A	0x1000	5100
LSI20320A-R	1020A	0x1000	5100

During system initialization, the system loads the ID numbers into the Subsystem Vendor ID and Subsystem ID registers of the embedded SCSI controller.

Figure 3.2 illustrates the LSIU320 and LSI20320A series of host adapters.

Figure 3.2 LSIU320, LSIU320-R, LSI20320A, and LSI20320A-R Host Adapter Drawing

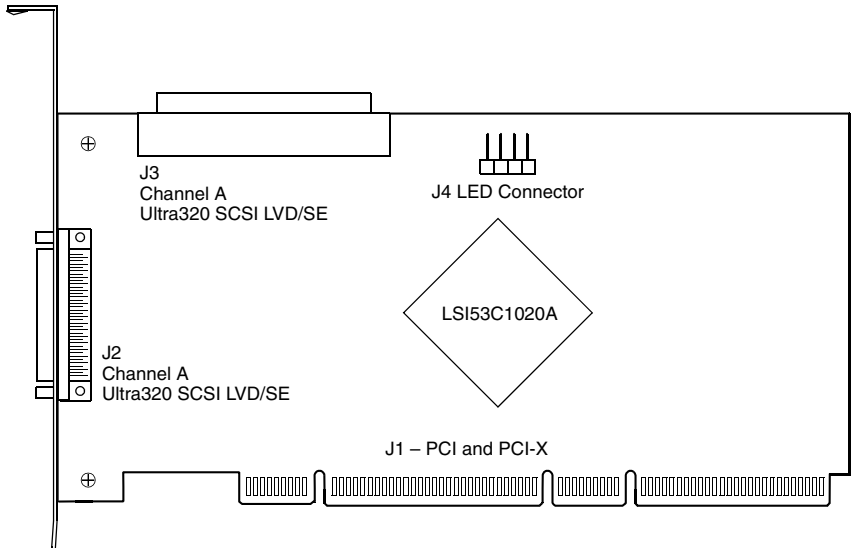

3.1.3 LSI20320IE and LSI20320ILE Single Channel Host Adapters

The LSI20320IE series of host adapters are single channel Ultra320 SCSI host adapters that provide one Ultra320 SCSI channel. The SCSI Channel A interface is made through connectors J2 and J3.

Features of the LSI20320IE series of host adapters are:

- Single Ultra320 SCSI channel
- Two SCSI connectors
 - One external 68-pin very high density cable interconnect (VHDCI) connection
 - One internal 68-pin high density (HD) connector
- PCI low profile bracket (LSI20320ILE)
- LVD/SE termination
- Fusion-MPT architecture

Details of the LSI20320IE series of host adapters are:

- J1: PCI Express, x4, universal type board edge connector
- J2: 68-pin VHDCI shielded right-angle external connector
- J3: 68-pin HD right-angle internal connector
- HDR2: 4-pin low density unshrouded right-angle LED connector
- Subsystem Vendor ID and Subsystem IDs are:

Host Adapter	Chip	Subsystem Vendor ID	Subsystem ID
LSI20320IE	1020A	0x1000	7100
LSI20320ILE	1020A	0x1000	7100

During system initialization, the system loads the ID numbers into the Subsystem Vendor ID and Subsystem ID registers of the embedded SCSI controller.

Figure 3.3 illustrates the LSI20320IE series of host adapters. The LSI20320ILE adapter uses a PCI low profile bracket.

Figure 3.3 LSI20320IE and LSI21320ILE Host Adapter Drawing

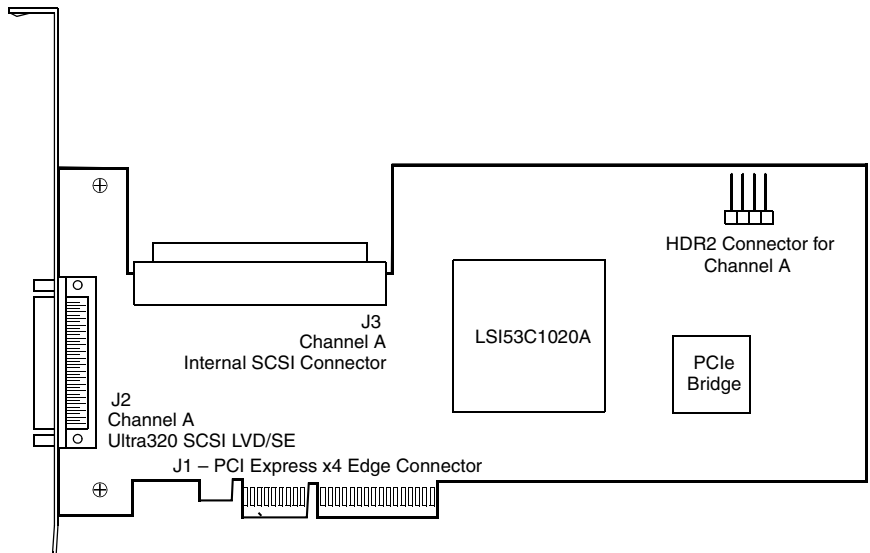

3.1.4 LSI21320 Dual Channel Host Adapters

The LSI21320 series of host adapters are dual channel Ultra320 SCSI host adapters that provide two Ultra320 SCSI channels. The SCSI Channel A interface is made through connectors J2 and J4. The SCSI Channel B interface is made through connector J3. See [Figure 3.4](#) for details.

Features of the LSI21320 series of host adapters are:

- Two independent Ultra320 SCSI channels
- Three SCSI connectors:
 - One external 68-pin HD connector
 - Two internal 68-pin HD connectors
- LVD/SE termination
- Integrated RAID (IR) solution applies to the “R” cards only
- Fusion-MPT architecture

Details of the LSI21320 series of host adapters are:

- J1: PCI and PCI-X, 64-bit, universal type board edge connector
- J2: 68-pin HD cable right-angle external connector
- J3 and J4: 68-pin HD right-angle internal connectors
- J6: 4-pin low density unshrouded right-angle LED connector
- Subsystem Vendor ID and Subsystem IDs are:

Host Adapter	Chip	Subsystem Vendor ID	Subsystem ID
LSI21320	1030	0x1000	10D0
LSI21320-R	1030	0x1000	30E0

During system initialization, the system loads the ID numbers into the Subsystem Vendor ID and Subsystem ID registers of the embedded SCSI controller.

Figure 3.4 illustrates the LSI21320 series of host adapter board.

Figure 3.4 LSI21320 and LSI21320-R Host Adapter Drawing

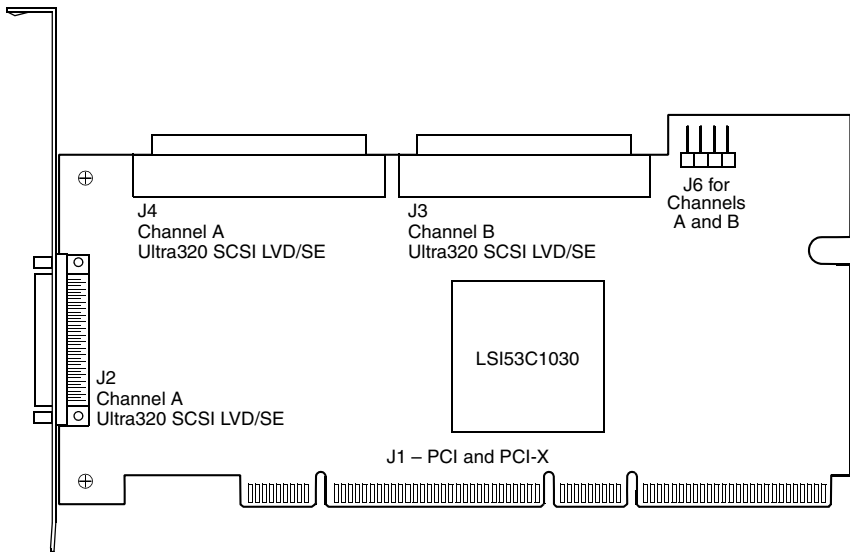

3.1.5 LSI22320 Dual Channel Host Adapters

The LSI22320 series of host adapters are dual channel Ultra320 SCSI host adapters that provide two Ultra320 SCSI channels. The SCSI Channel A interface is made through connectors J2 and J6. The SCSI Channel B interface is made through connectors J3 and J4. See [Figure 3.5](#) and [Figure 3.6](#) for details.

Features of the LSI22320 series of host adapters are:

- Two independent Ultra320 SCSI channels
- Four SCSI connectors:
 - Two external 68-pin VHDCI connectors
 - Two internal 68-pin HD connectors
- LVD/SE termination
- Integrated RAID (IR) solution applies to the “R” cards only
- Fusion-MPT architecture

Details of the LSI22320 series of host adapters are:

- J1: PCI and PCI-X, 64-bit, universal type board edge connector
- J2 and J3: 68-pin VHDCI right-angle external connectors
- J4 and J6: 68-pin HD right-angle internal connectors
- J5: 4-pin low density unshrouded right-angle LED connector
- Subsystem Vendor ID and Subsystem IDs are:

Host Adapter	Chip	Subsystem Vendor ID	Subsystem ID
LSI22320	1030	0x1000	1010
LSI22320-R	1030	0x1000	30B0
LSI22320T	1030T	0x1000	1110

During system initialization, the system loads the ID numbers into the Subsystem Vendor ID and Subsystem ID registers of the embedded SCSI controller.

Figure 3.5 illustrates the LSI22320 series of host adapter, and Figure 3.6 illustrates the LSI22320T host adapter.

Figure 3.5 LSI22320 and LSI22320-R Host Adapter Drawing

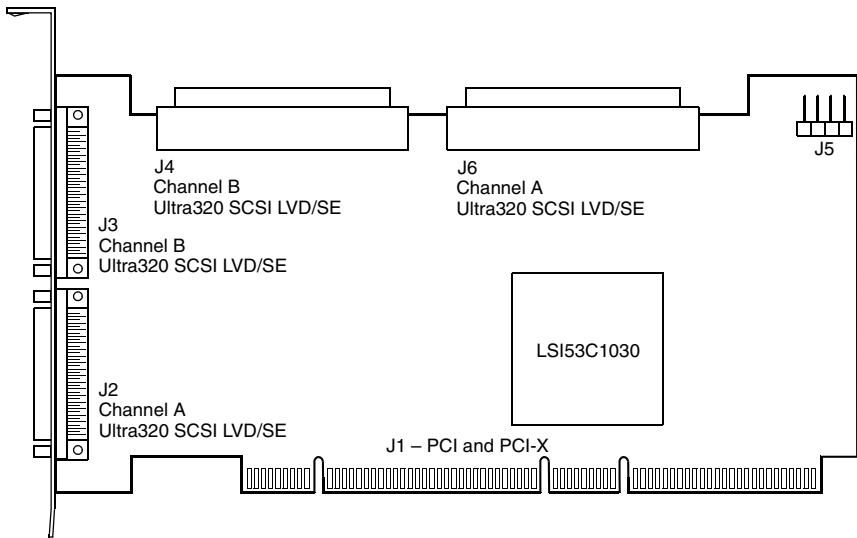
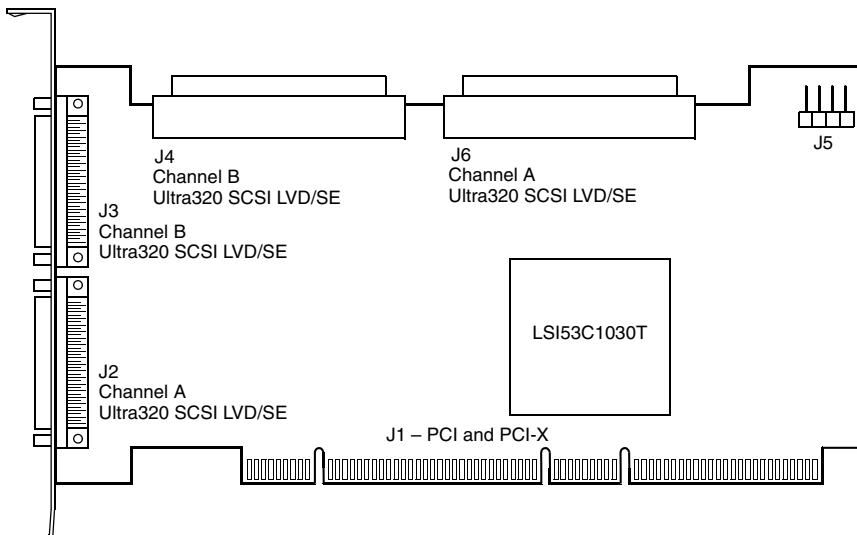

Figure 3.6 LSI22320T Host Adapter Drawing



3.1.6 LSI22320SE and LSI22320SLE Dual Channel Host Adapters

The LSI22320SE series of host adapters are dual channel Ultra320 SCSI host adapters that provide two Ultra320 SCSI channels. The SCSI Channel A interface is made through connector J2. The SCSI Channel B interface is made through connectors J3. See [Figure 3.7](#) for details.

Features of the LSI22320SE and LSI22320SLE host adapters are:

- Two independent Ultra320 SCSI channels
- Two SCSI connectors:
 - Two external 68-pin VHDCI connectors (stacked)
- LVD/SE termination
- Fusion-MPT architecture

Details of the LSI22320SE series of host adapters are:

- J1: PCI Express x4 lanes, serial board edge connector
- J2 and J3: 68-pin VHDCI right-angle external connectors
- HDR2: 4-pin low density unshrouded right-angle LED connector
- Subsystem Vendor ID and Subsystem IDs are:

Host Adapter	Chip	Subsystem Vendor ID	Subsystem ID
LSI22320SE	1030	0x1000	10B0
LSI22320SLE	1030	0x1000	10B0

During system initialization, the system loads the ID numbers into the Subsystem Vendor ID and Subsystem ID registers of the embedded SCSI controller.

Figure 3.7 illustrates the LSI22320SE and the LSI22320SLE host adapter.

Figure 3.7 LSI22320SE and LSI22320SLE Host Adapter Drawing

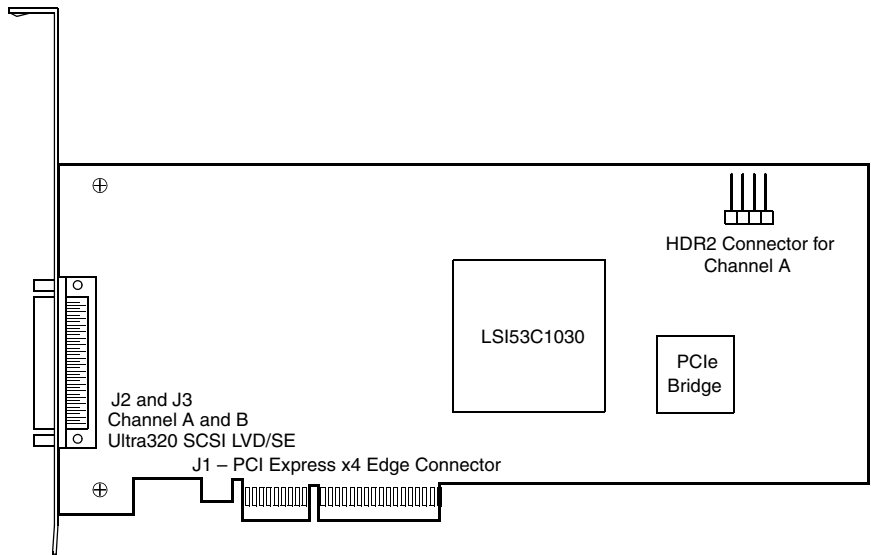

3.2 Host Adapter Characteristics

Table 3.2 shows the general characteristics for all Ultra320 SCSI host adapters.

Table 3.2 Host Adapter Characteristics

Flash ROM ¹	Serial EEPROM ²	LVD/SE Signaling	Ultra320 SCSI Data Transfers	SCSI Features	SCSI Termination
Yes	Yes	16-bit SE or LVD interfaces	Up to 320 Mbytes/s as well as Fast, Ultra, Ultra2, and Ultra160 speeds; Synchronous offsets up to 62.	Plug and Play Scatter/Gather Activity LED	TERMPWR with autoresetting circuit breaker

1. For boot code and firmware.
2. For BIOS configuration storage.

Each Ultra320 SCSI host adapter offers SureLINK Domain Validation technology to ensure data integrity by intelligently validating the compatibility of the SCSI domain. These adapters also utilize Fusion-MPT architecture that allows for thinner drivers and better performance.

3.3 Technical Specifications

The design and implementation of the Ultra320 SCSI host adapters minimize electromagnetic emissions, susceptibility to radio frequency energy, and the effects of electrostatic discharge. The adapter carries the CE mark, C-Tick mark, FCC Self-Certification logo, Canadian Compliance Statement, Korean MIC, Taiwan BSMI, Japan VCCI, and meets the requirements of CISPR Class B.

3.3.1 Electrical Characteristics

Table 3.3 lists the maximum power requirements for standard Ultra320 SCSI host adapters, including SCSI TERMPWR, under normal operation.

Table 3.3 Maximum Power Requirements

Host Adapter	PCI/PCI-X +5.0 V	PCI/PCI-X +3.3 V	PCI Express +12 V	PCI PRSNT1#/ PRSNT2# Power	Temperature Range
LSI20320 LSI20320-R LSI20320L-R	1.5 A	2.0 A	–	15 W	0 °C to 55 °C
LSIU320 LSIU320-R LSI20320A LSI20320A-R	1.5 A	2.0 A	–	7.5 W	0 °C to 55 °C
LSI20320IE LSI20320ILE	–	–	0.6 A	7.2 W	0 °C to 55 °C
LSI21320 LSI21320-R	1.5 A	2.5 A	–	15 W	0 °C to 55 °C
LSI22320 LSI22320-R LSI22320T	2.5 A	0.0 A	–	15 W	0 °C to 55 °C
LSI22320SE LSI22320SLE	–	–	0.94 A	11.28 W	0 °C to 55 °C

3.3.2 Thermal and Atmospheric Characteristics

The thermal and atmospheric characteristics for all Ultra320 SCSI host adapters are:

- Temperature range: 0 °C to 55 °C (dry bulb)
- Relative humidity range: 5% to 90% noncondensing
- Maximum dew point temperature: 32 °C
- Airflow must be sufficient to keep the LSI53C1020 and LSI53C1030 heat sink temperature below 80 °C
- Host adapters using the LSI53C1020A do not require a heat sink

The following parameters define the storage and transit environment for the Ultra320 SCSI host adapters:

- Temperature range: –40 °C to 105 °C (dry bulb)
- Relative humidity range: 5% to 90% noncondensing

3.3.3 Safety Characteristics

All Ultra320 SCSI host adapters meet or exceed the requirements of UL flammability rating 94 V0. Each bare board is also marked with the supplier's name or trademark, type, and UL flammability rating. Because these boards are installed in a PCI bus slot, all voltages are below the SELV 42.4 V limit.

Appendix A

Glossary of Terms

Active Termination	The electrical connection required at each end of the SCSI bus, composed of active voltage regulation and a set of termination resistors. Ultra SCSI, Ultra2 SCSI, Ultra160 SCSI, and Ultra320 SCSI require active termination.
BIOS	Basic Input/Output System. Software that provides basic read/write capability. Usually kept as firmware (ROM-based). The system BIOS on the mainboard of a computer boots and controls the system. The SCSI BIOS on the host adapter acts as an extension of the system BIOS.
Configuration	Refers to the way a computer is set up; the combined hardware components (computer, monitor, keyboard, and peripheral devices) that make up a computer system; or the software settings that allow the hardware components to communicate with each other.
Device Driver	A program that allows a microprocessor (through the operating system) to direct the operation of a peripheral device, such as a disk drive.
Domain Validation	A software procedure in which a host queries a device to determine its ability to communicate at the negotiated data rate.
EEPROM	Electrically Erasable Programmable Read Only Memory. A memory chip that typically stores configuration information.
External SCSI Device	A SCSI device installed outside the computer cabinet. These devices are connected together using specific types of shielded cables.
Fusion-MPT Architecture	Fusion-MPT (Message Passing Technology) architecture consists of several main elements: Fusion-MPT firmware, the Fibre Channel and SCSI hardware, and the operating system level drivers that support these architectures. Fusion-MPT architecture offers a single binary, operating system driver that supports both Fibre Channel and SCSI devices.

Host	The computer system in which a SCSI host adapter is installed. It uses the SCSI host adapter to transfer information to and from devices attached to the SCSI bus.
Host Adapter	A circuit board or integrated circuit that provides a device connection to the host.
Integrated RAID (IR) Solution	The LSI Integrated RAID solution provides either the Integrated Mirroring (IM) solution, which provides features of RAID 1 and RAID 1E, or the Integrated Striping (IS) solution, which provides features of RAID 0.
Integrated Mirroring (IM) Solution	The LSI Integrated Mirroring (IM) solution provides features of RAID 1 and RAID 1E. The IM feature provides data protection for the system boot volume to safeguard critical information such as the operating system on servers and high performance workstations. The IM feature gives customers a robust, high-performance, fault-tolerant solution that is less expensive than a dedicated RAID controller.
Integrated Striping (IS) Solution	The LSI Integrated Striping (IS) solution provides features of RAID 0. The IS feature is a low-cost solution with many of the features of a more expensive RAID striping solution. A single IS logical drive may be configured as the boot disk or as a data disk.
Internal SCSI Device	A SCSI device installed inside the computer cabinet. These devices are connected to one another with an unshielded ribbon cable.
PCI and PCI-X	Peripheral Component Interconnect. A high performance local bus specification that allows connection of devices directly to computer memory. The PCI Local Bus allows transparent upgrades from a 32-bit data path at 33 MHz to a 64-bit data path at 33 MHz; from a 32-bit data path at 66 MHz to a 64-bit data path at 66 MHz; and from a 32-bit data path at 133 MHz to a 64-bit data path at 133 MHz (1064 Mbytes/s peak).
PCI Express	PCI Express is the third generation high performance I/O bus that interconnects peripheral devices. PCI Express replaces parallel PCI bus with a highly scalable, fully serial interface. PCI Express takes advantage of recent advances in point-to-point interconnects, switchbased technology, and packetized protocol to deliver new levels of performance and features.
Peripheral Device	A piece of hardware (such as a disk drive, printer, or CD-ROM) used with a computer and under the computer's control. SCSI peripheral devices are controlled through a SCSI host adapter.

RAID	Redundant Array of Independent Disks. An array of multiple independent hard disk drives that yields better performance than a Single Large Expensive Disk (SLED). A RAID disk subsystem improves I/O performance on a server using only a single drive. The RAID array appears to the host server as a single storage unit. I/O is expedited because several disks can be accessed simultaneously.
RAID 0	Provides block “striping” across multiple drives, yielding higher performance than is possible with individual drives. This level does not provide any redundancy.
RAID 1	Drives are paired and mirrored. All data is 100 percent duplicated on a drive of equivalent size.
SCSI Bus	A host adapter and one or more SCSI devices connected by cables in a linear configuration. The host adapter may exist anywhere on the bus, allowing connection of both internal and external SCSI devices. A system may have more than one SCSI bus by using a multichannel host adapter or by using multiple host adapters.
SCSI Device	Any device that conforms to the SCSI standard and is attached to the SCSI bus by a SCSI cable. This includes SCSI host adapters, SCSI disk drives, SCSI CD-ROM drives, and so on.
SCSI ID	An identifier that addresses specific devices on the SCSI bus and determines device selection when multiple devices contend for ownership of the SCSI bus. Wide SCSI buses support SCSI IDs 0–15, and narrow SCSI buses support SCSI IDs 0–7. A device gains ownership of the bus according to the priority of its SCSI ID. The order of priority, from highest to lowest, is: 7, 6, 5, 4, 3, 2, 1, 0, 15, 14, 13, 12, 11, 10, 9, 8. The host adapter is usually set to the highest priority SCSI ID, which is SCSI ID 7.
Single-Ended SCSI	A hardware specification for connecting SCSI devices. It references each SCSI signal to a common ground. In contrast, differential SCSI uses a separate ground for each signal.
SureLINK Feature	The domain validation method developed and used by LSI. SureLINK Domain Validation provides three levels of integrity checking: Basic (level 1), Enhanced (level 2), and Margined (level 3).
Ultra SCSI	A standard for SCSI data transfers. It allows a transfer rate of up to 20 Mbytes/s over an 8-bit SCSI bus and up to 40 Mbytes/s over a 16-bit SCSI bus.

- Ultra2 SCSI** A standard for SCSI data transfers. It allows a transfer rate of up to 40 Mbytes/s over an 8-bit SCSI bus, and up to 80 Mbytes/s over a 16-bit SCSI bus.
- Ultra160 SCSI** A standard for SCSI data transfers. It allows a transfer rate of up to 160 Mbytes/s over a 16-bit SCSI bus.
- Ultra320 SCSI** A standard for SCSI data transfers. It allows a transfer rate of up to 320 Mbytes/s over a 16-bit SCSI bus.
- VHDCI** Very High Density Cable Interconnect. VHDCI cables connect external SCSI devices to the host adapter.

Customer Feedback

We would appreciate your feedback on this document. Please copy the following page, add your comments, and fax it to us at the number shown.

If appropriate, please also fax copies of any marked-up pages from this document.

Important: Please include your name, phone number, fax number, and company address so that we may contact you directly for clarification or additional information.

Thank you for your help in improving the quality of our documents.

Reader's Comments

Fax your comments to: LSI Logic Corporation
Technical Publications
M/S AF-198
Fax: 408.433.4333

Please tell us how you rate this document: *Ultra320 SCSI Host Adapters User's Guide*. Place a check mark in the appropriate blank for each category.

	Excellent	Good	Average	Fair	Poor
Completeness of information	_____	_____	_____	_____	_____
Clarity of information	_____	_____	_____	_____	_____
Ease of finding information	_____	_____	_____	_____	_____
Technical content	_____	_____	_____	_____	_____
Usefulness of examples and illustrations	_____	_____	_____	_____	_____
Overall manual	_____	_____	_____	_____	_____

What could we do to improve this document?

If you found errors in this document, please specify the error and page number. If appropriate, please fax a marked-up copy of the page(s).

Please complete the information below so that we may contact you directly for clarification or additional information.

Name _____ Date _____

Telephone _____ Fax _____

Title _____

Department _____ Mail Stop _____

Company Name _____

Street _____

City, State, Zip _____