

**LSI® SAS 9207-8i**  
**PCI Express® to 6Gb/s Serial Attached SCSI (SAS)**  
**Host Bus Adapter**  
**User Guide**

Version 2.2  
October 2014

DB15-000857-03

For a comprehensive list of changes to this document, see the [Revision History](#).

Corporate Headquarters	Email	Website
San Jose, CA 800-372-2447	<a href="mailto:globalsupport.pdl@avagotech.com">globalsupport.pdl@avagotech.com</a>	<a href="http://www.lsi.com">www.lsi.com</a>

Avago Technologies, the A logo, LSI, Storage by LSI, and Fusion-MPT are trademarks of Avago Technologies in the United States and other countries. All other brand and product names may be trademarks of their respective companies.

Data subject to change. Copyright © 2011–2014 Avago Technologies. All Rights Reserved.

---

# Table of Contents

1 Overview .....	4
2 HBA Features .....	4
3 Functional Descriptions .....	4
3.1 PCI Express Host Interface .....	4
3.2 SAS-2 Interface .....	5
4 Operating System Support .....	5
5 LSI SAS 9207-8i HBA Characteristics .....	5
5.1 Flash .....	5
5.2 LED .....	5
5.3 Connectors .....	5
5.4 Physical Characteristics .....	6
5.5 Power Requirements .....	6
5.6 Thermal and Atmospheric Limits .....	6
6 LSI SAS 9207-8i HBA Certifications and Safety Characteristics .....	7
7 Hardware Installation .....	7
8 Technical Support .....	8
9 Revision History .....	9
9.1 Version 2.2, October 2014 .....	9
9.2 Version 2.1, May 2012 .....	9
9.3 Version 2.0, January 2012 .....	9
9.4 Version 1.0, July 2011 .....	9

---

# LSI® SAS 9207-8i PCI Express to 6Gb/s SAS HBA User Guide

## 1 Overview

The LSI® SAS 9207-8i PCI Express® (PCIe®)-to-Serial Attached SCSI (SAS) host bus adapter (HBA), referred to as the LSI SAS 9207-8i HBA, provides high-performance internal storage connectivity for servers and workstations. The LSI SAS 9207-8i HBA provides eight lanes of 6Gb/s SAS storage connectivity and is matched with eight lanes of PCIe 3.0 8Gb/s host connectivity. The low-profile design of the SAS HBA includes a full-height bracket and low-profile mounting bracket that creates a universal fit for any server. The LSI SAS 9207-8i HBA is based on the Fusion-MPT™ architected LSI SAS 2308 controller that integrates the latest enhancements in PCIe 3.0 technology and 6Gb/s SAS technology.

The LSI SAS 9207-8i HBA has onboard Flash memory for the firmware and BIOS.

## 2 HBA Features

This section lists the LSI SAS 9207-8i HBA features.

- Implements one LSI SAS 2308 eight-port 6Gb/s to PCIe 3.0 controller
- Supports eight-lanes, full-duplex PCIe 3.0 performance
- Supports eight internal 6Gb/s SATA+SAS ports
- Supports SAS link rates of 1.5Gb/s, 3.0Gb/s, and 6.0Gb/s
- Provides two x4 internal mini-SAS connectors (SFF-8087) with sidebands
- Supports up to 256 SATA or SAS end devices
- Offered with a full-height bracket and low-profile vented bracket
- Provides one heartbeat LED
- Uses sideband signals in multilane connectors to support serial general purpose input/output (SGPIO)

## 3 Functional Descriptions

### 3.1 PCI Express Host Interface

PCIe is a high-speed standard local bus for point-to-point interfacing of I/O components to the processor and the memory subsystems in a high-end computers and servers. The LSI SAS 2308 controller chip contains the PCIe functionality for the LSI SAS 9207-8i HBA. The LSI SAS 2308 controller chip connects directly to the PCIe bus and generates timing and protocol in compliance with the PCIe specifications.

The LSI SAS 9207-8i HBA supports eight-lane PCIe performance up to 64Gb/s single direction and 128Gb/s dual direction.

## 3.2 SAS-2 Interface

The LSI SAS 2308 controller chip contains the SATA + SAS functionality for the LSI SAS 9207-8i HBA. The following table shows the LSI SAS 9207-8i HBA 6Gb/s SAS performance.

**Table 1 6Gb/s SAS Bandwidths**

Half Duplex	Full Duplex
Narrow port (one lane), 600 MB/s	Narrow port (one lane), 1200 MB/s
Wide port (four lanes), 2400 MB/s	Wide port (four lanes), 4800 MB/s

## 4 Operating System Support

The LSI SAS 9207-8i HBA supports all major operating systems: Windows®, Linux® Red Hat®, Linux SUSE® Enterprise Server (SLES), Solaris™, VMware®, and FreeBSD®. Refer to <http://go.lsi.com/hbas> for details on the software versions and device driver support.

**NOTE** The LSI SAS 9207-8i HBA supports Solaris 10 and Oracle® provides a built-in driver; installation of an LSI driver is not required. For more information on the Oracle Solaris 10 driver and installation, sign in at the following Oracle link.

<https://support.oracle.com/>

Contact Oracle support for Oracle driver or software support.

## 5 LSI SAS 9207-8i HBA Characteristics

### 5.1 Flash

The LSI SAS 9207-8i HBA has onboard Flash ROM for the firmware and BIOS. The LSI SAS 9207-8i HBA provides one 4 M x 16-bit Flash ROM for storing the firmware and BIOS.

### 5.2 LED

The LSI SAS 9207-8i HBA Heartbeat LED, CR1, blinks green to indicate that the HBA is capable of general activity.

### 5.3 Connectors

This section describes the different connectors on the LSI SAS 9207-8i HBA.

**PCIe Connector (EC1).** The LSI SAS 9207-8i HBA supports a x8 interface. The PCIe connection is through the edge connector (EC1), which provides connections on both the top (EC1B) and bottom (EC1A) of the board. The signal definitions and pin numbers conform to the PCIe specification.

**SAS Connectors (J5 and J6).** The LSI SAS 9207-8i HBA supports SAS connections through connectors J5 and J6, which are SFF-8087 mini-SAS, internal connectors. The HBA supports SAS sideband signal assignments.

## 5.4 Physical Characteristics

The LSI SAS 9207-8i HBA is a 167.6-mm x 64.5-mm (6.6-in. x 2.54-in.), low-profile board. The component height on the top and bottom of the LSI SAS 9207-8i HBA is in accordance with the PCIe specification. The following figure shows the board layout.

**Figure 1 LSI SAS 9207-8i HBA Board Layout**

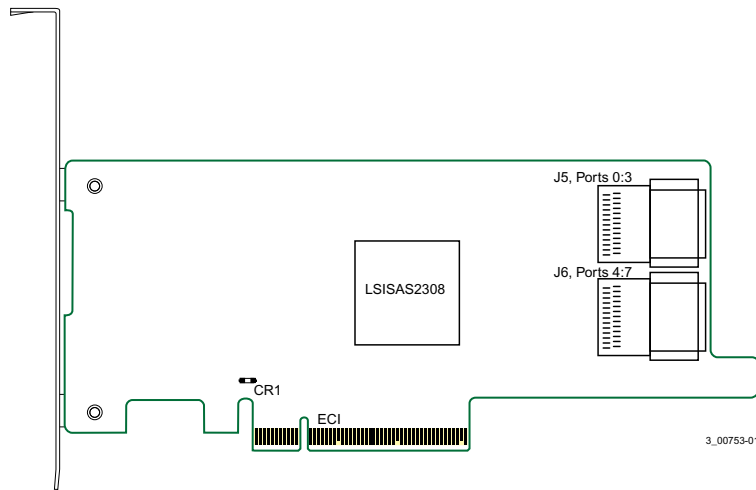

- EC1: PCIe x8-lane board edge connector
- CR1: Heartbeat LED
- J5, J6: SFF-8087, mini-SAS internal connectors

## 5.5 Power Requirements

The maximum power requirements for the LSI SAS 9207-8i HBA under normal operation are as follows:

- PCIe 12.0 V = 1.3 A
- Power
  - Nominal = 9.8 W
  - Worst case = 16.0 W

## 5.6 Thermal and Atmospheric Limits

The atmospheric limits for the LSI SAS 9207-8i HBA operation are as follows:

- Temperature range: 0 °C to 55 °C (32 °F to 131 °F) (dry bulb)
- Relative humidity range: 5 percent to 90 percent noncondensing
- Maximum dew point temperature: 32 °C (89.6 °F)
- Minimum airflow: 200 linear feet per minute

The following limits define the storage and transit environment for the LSI SAS 9207-8i HBA:

- Temperature range: -45 °C to +105 °C (-49 °F to +221 °F) (dry bulb)
- Relative humidity range: 5 percent to 90 percent noncondensing

---

## 6 LSI SAS 9207-8i HBA Certifications and Safety Characteristics

The LSI SAS 9207-8i HBA meets or exceeds the requirements of UL flammability rating 94V-0. Each bare board is marked with the supplier's name or trademark, type, and UL flammability rating. Because these boards are installed in a PCIe bus slot, all voltages are less than the SELV 42.4-V limit.

The design and implementation of the LSI SAS 9207-8i HBA minimizes electromagnetic emissions, susceptibility to radio frequency energy, and the effects of electrostatic discharge.

The LSI SAS 9207-8i HBA meets the following integrated electromagnetic interference (EMI) compliance labels:

- CE mark
- CISPR Class B
- C-Tick mark
- Canadian Compliance Statement
- FCC Class B, marked with the FCC Self-Certification logo
- Japan VCCI
- Korean KCC
- Taiwan BSMI

The LSI SAS 9207-8i HBA meets the following environmental directives:

- RoHS
- WEEE

## 7 Hardware Installation

The installation instructions for the LSI SAS 9207-8i HBA follow.

1. **Unpack the HBA, and inspect it for damage.** Unpack the HBA in a static-free environment. Remove the HBA from the antistatic bag, and carefully inspect it for damage. If you notice any damage contact LSI or your reseller support representative.

**ATTENTION** Make a backup of your data before changing your system configuration to avoid the risk of data loss.

2. **Prepare the computer.** Turn off the computer, and disconnect the power cord from the rear of the power supply.

**CAUTION** Disconnect the computer from the power supply and from any networks before you install the HBA, or you risk damaging the system or electrical shock.

3. **Remove the cover from the chassis.**
4. **Replace the mounting bracket (system dependent).** If required for your system, replace the full-height mounting bracket that ships on the LSI SAS 9207-8i HBA with the low-profile bracket supplied. Save and reuse the two screws that attach the long bracket to attach the short bracket.
5. **Insert the HBA in an available PCIe slot.** Locate an empty x8 PCIe slot. Remove the blank bracket panel on the rear of the computer that aligns with the empty PCIe slot. Save the bracket screw, if applicable.

Align the HBA to a PCIe slot. Press down gently, but firmly, to correctly seat the HBA in the slot. The following figure shows how to insert the HBA in a PCIe slot.

**Figure 2** Installing an LSI SAS 9207-8i HBA in a PCI Express Slot

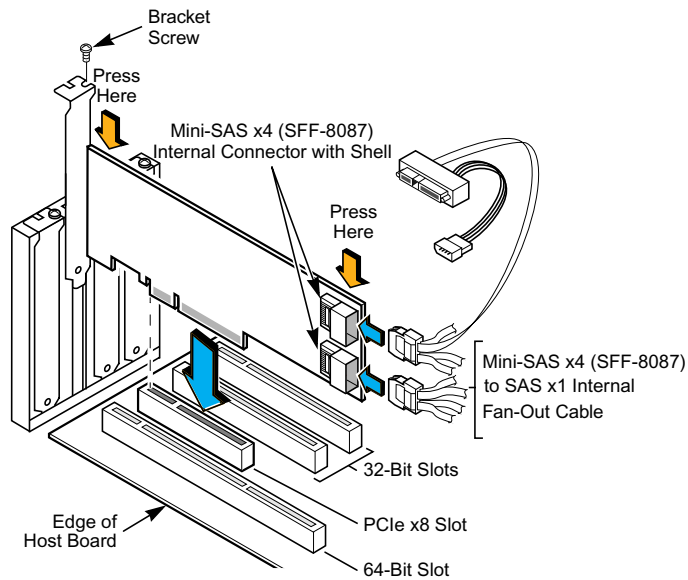

**NOTE** The shape, size, and locations of components on your HBA and its bracket might vary from this illustration. The LSI SAS 9207-8i HBA requires a x8 PCIe slot.

6. **Secure the HBA bracket to the system's chassis.** Install the bracket screw, if applicable, or engage the system retention mechanism to secure the HBA to the system's chassis.
7. **Connect SAS cables between the HBA and the SAS backplane or any other SATA or SAS devices.** Connect serial cables between the HBA and the SAS backplane or any other SATA or SAS devices. The preceding figure shows the locations of the HBA connectors. The LSI SAS 9207-8i HBA has two internal x4 mini-SAS, SFF-8087 connectors that the LSI SAS 9207-8i HBA kit includes. You may use other appropriate cables to a specific system.
8. **Replace the cover and any power cords, and power up the system.** Replace the chassis's cover, reconnect any power cords, and reconnect any network cables. Turn on the power.

The hardware installation of your LSI SAS 9207-8i HBA is complete.

## 8 Technical Support

For assistance installing, configuring, or running the LSI SAS 9207-8i HBA, contact Technical Support:

**E-mail:** [globalsupport.pdl@avagotech.com](mailto:globalsupport.pdl@avagotech.com)

**Web Site:** [www.lsi.com/support/](http://www.lsi.com/support/)



---

## 9 Revision History

### 9.1 Version 2.2, October 2014

Made the following changes:

- Updated support information.
- Converted the book to the new template.

### 9.2 Version 2.1, May 2012

Made the following change:

- Updated [Section 5.5, Power Requirements](#).

### 9.3 Version 2.0, January 2012

Made the following change:

- Renamed the LSI SAS 9215-8i host bus adapter to the LSI SAS 9207-8i host bus adapter.

### 9.4 Version 1.0, July 2011

Initial release of the document.

**AVAGO**  
TECHNOLOGIES

STORAGE  
BY **LSI**™