



This addendum contains new and changed information for the SYM53C810A Data Manual Version 2.0, published in August 1996. The information will be added to the next version of the manual. The changes are listed in the order in which their appropriate chapters appear in the data manual. The Power Management features of the SYM53C810AE enable it to comply with Microsoft's PC 97 Hardware Design Guide. This addendum applies to both devices, SYM53C810A and SYM53C810AE, except where noted.

Chapter 2, Functional Description

Figure 2-4, "Determining the Synchronous Transfer Rate," was inadvertently omitted. See the reference to this figure under the main heading "Synchronous Operation." The drawing appears below.

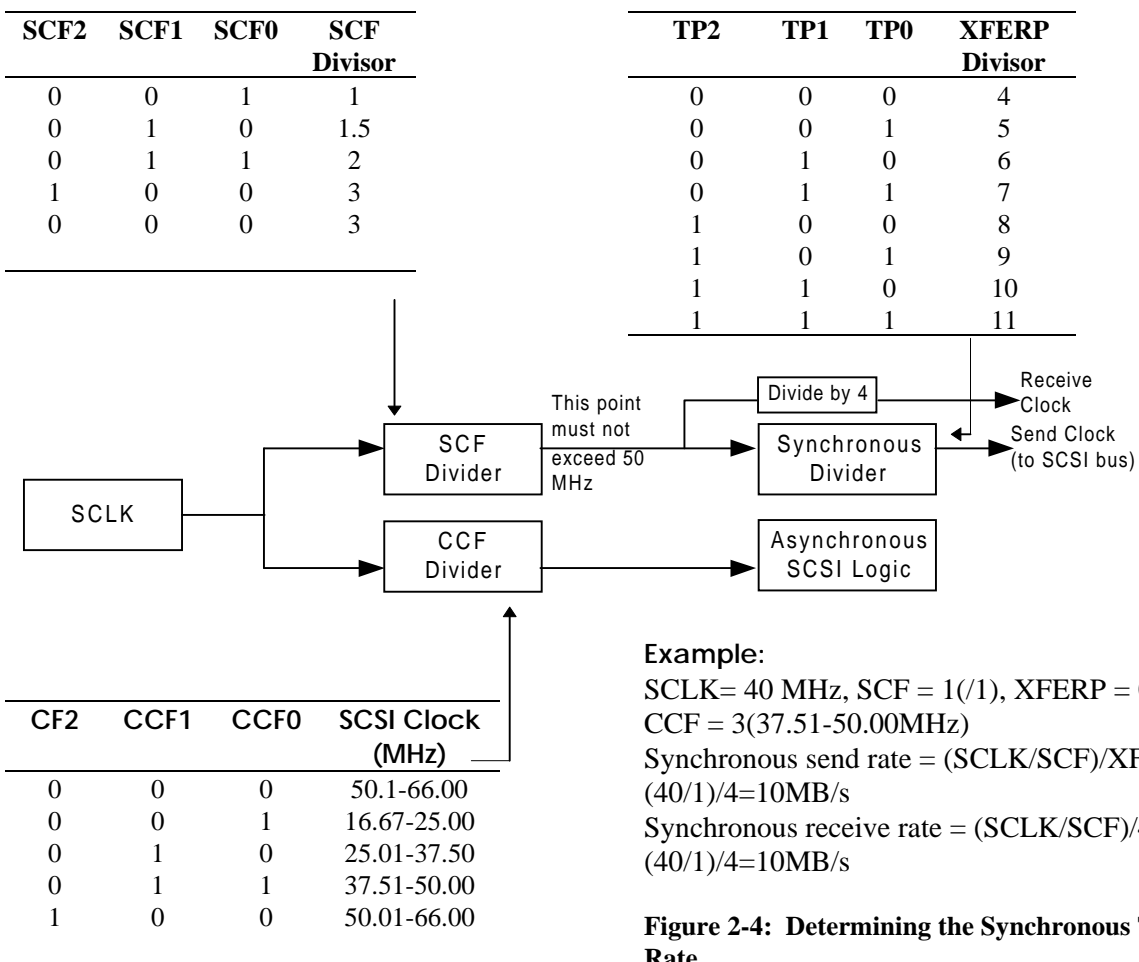

Figure 2-4: Determining the Synchronous Transfer Rate

Achieving Optimal SCSI Send Rates

In this section on page 2-11, the example at the end of the paragraph is incomplete. The TP and SCF bit settings given in the example will achieve a synchronous send rate of 5 MB/s.

Power Management

The SYM53C810AE complies with the PCI Bus Power Management Interface Specification, Revision 1.0. The PCI Function Power States are defined in that specification: D0, D1, D2, and D3. D0 and D3 are required by specification and D1 and D2 are optional. D0 is the maximum powered state, and D3 is the minimum powered state. Power state D3 is further categorized as D3hot or D3cold. A function that is powered off is said to be in the D3cold power state.

The power states for the SCSI function are independently controlled through two power state bits that are located in the PCI Configuration Space Register 44h. The bits are encoded as: 00b – power state D0, 01b - reserved, 10b - reserved, and 11b - power state D3.

The power states--D0 and D3--are described below. Power states D1 and D2 are not implemented for this device.

Power State D0

Power state D0 is the maximum power state and is the power-up default state for each function.

Power State D3

Power state D3 is the minimum power state, which includes subsettings called D3hot and D3cold. The devices are considered to be in power state D3cold when power is removed from them. D3cold can transition to D0 by applying Vcc and resetting the device. D3hot allows the device to transition to D0 via software. To obtain power reduction in D3hot, the SCSI clock and the SCSI clock doubler Phase Lock Loop (PLL) are disabled. Furthermore, soft reset is continually asserted while in power state D3hot, which clears all pending interrupts and tristates the SCSI bus. In addition, the function's PCI command register is cleared.

Chapter 3, PCI Functional Description

Configuration Registers

Figure 3-1: PCI Configuration Register Map

31		16	15		0	
Device ID		Vendor ID = 1000h				00h
Status		Command				04h
Class Code			Rev ID			08h
Not Supported	Header Type	Latency Timer		Cache Line Size		0Ch
Base Address Zero (I/O), SCSI Operating Registers						10h
Base Address One (Memory), SCSI Operating Registers						14h
Base Address Two (Memory) SCRIPTS RAM						18h
Not Supported						1Ch
Not Supported						20h
Not Supported						24h
Reserved						28h
Subsystem ID			Subsystem Vendor ID			2Ch
Expansion ROM Base Address						30h
Reserved				Capabilities Pointer		34h
Reserved						38h
Max_Lat	Min_Gnt	Interrupt Pin		Interrupt Line		3Ch
Power Management Capabilities			Next Item Pointer		Capability ID	40h
Data	Bridge Support Ext		Pwr. Mgmt. Control/Status Register			44h

Note: Shaded areas are reserved or represent the SYM53C810AE capabilities.

Configuration Register Changes
for
SYM53C810AE

Register 2Ch
Subsystem Vendor ID (SSVID)
Read Only

SVID	SVID	SVID	SVID
15-12	11-8	7-4	3-0
Default>>>			
1	0	0	0

This register supports subsystem identification, which has a default value of 1000h in the SYM53C810AE.

Register 2Eh
Subsystem ID (SSID)
Read Only

SID	SID	SID	SID
15-12	11-8	7-4	3-0
Default>>>			
1	0	0	0

This register supports subsystem identification, which has a default value of 1000h in the SYM53C810AE.

Register 06h
Status
Read/Write

DPE	SSE	RMA	RTA	RES	DT	DPR	RES	NC	RES
15	14	13	12	11	10-9	8	7-5	4	3-0
Default >>>									
0	0	0	0	0	0	0	0	1	0

Reads to this register behave normally. Writes are slightly different in that bits can be cleared, but not set. A bit is reset whenever the register is written and the data in the corresponding bit location is a one. For instance, to clear bit 15 and not affect any other bits, write the value 8000h to the register.

Please note the following changes to Register 06h bits 7-0.

Bits 7-5 Reserved

Bit 4 New Capabilities (NC)

This bit is set to indicate the presence of a list of extended capabilities such as PCI Power Management. This bit is Read Only.

Bits 3-0 Reserved

Register 08h

Revision ID

Read Only

RID	RID	RID	RID	RID	RID	RID	RID
7	6	5	4	3	2	1	0
Default >>>							
0	0	1	0	0	0	1	1

This field specifies device and revision identifiers. The value of this register is 23h.

Register 34h

Capability Pointer

Read Only

CP	CP	CP	CP	CP	CP	CP	CP
7	6	5	4	3	2	1	0
Default >>>							
0	1	0	0	0	0	0	0

This register provides an offset into the function's PCI Configuration Space for the location of the first item in the capabilities linked list. This register is set by the device to 40h.

Register 40h

Capability ID

Read Only

CID	CID	CID	CID	CID	CID	CID	CID
7	6	5	4	3	2	1	0
Default >>>							
0	0	0	0	0	0	0	1

This register indicates the type of the current data structure (linked list item). This register is set by the device to a value of 01h, indicating the Power Management Data Structure.

Register 41h

Next Item Pointer

Read Only

NP	NP	NP	NP	NP	NP	NP	NP
7	6	5	4	3	2	1	0
Default >>>							
0	0	0	0	0	0	0	0

This register describes the location of the next item in the function's capability list. This register is set by the device to a value of 00h, indicating that power management is the last capability in the linked list of extended capabilities.

Register 42h
Power Management Capabilities
Read Only

PMES	D2S	D1S	RES	DSI	APS	PMEC	VER
15-11	10	9	8-6	5	4	3	2-0
Default >>>							
0	0	0	0	0	0	0	1

This register indicates the power management capabilities.

Bits 15-11 PME Support (PMES)

This field always returns a zero value because the devices do not provide a PME signal.

Bit 10 D2 Support (D2S)

This device does not support the D2 power management state.

Bit 9 D1 Support (D1S)

This device does not support the D1 power management state.

Bits 8-6 Reserved

Bit 5 Device Specific Initialization (DSI)

This bit is set to 0 to indicate that the device requires no special initialization before the generic class device driver is able to use it.

Bit 4 Auxiliary Power Source (APS)

Because the device does not provide a PME signal, this bit always returns a 0. This indicates that no auxiliary power source is required to support the PME signal in the D3cold power management state.

Bit 3 PME Clock (PMEC)

This bit always returns a 0b value because the SYM53C810AE does not provide a PME signal.

Bits 2-0 Version (VER)

This field is set to 001b to indicate that the device complies with Revision 1.0 of the PCI Power Management Interface Specification.

Register 44h
Power Management Control/Status
Read/Write

PST	DSCL	DSLTL	PEN	RES	PWS
15	14-13	12-9	8	7-2	1-0
Default >>>					
0	0	0	0	0	0

This register indicates the power management control and status descriptions.

Bit 15 PME Status (PST)

The device always returns a 0 for this bit, indicating that PME signal generation is not supported from D3cold.

Bits 14-13 Data Scale (DSCL)

The device does not support the Data register, therefore this field is always set to 00b.

Bits 12-9 Data Select (DSLTL)

The device does not support the Data register, therefore this field is always set to 0000b.

Bit 8 PME Enable (PEN)

The device always returns a 0 for this bit to indicate that PME assertion is disabled.

Bits 7-2 Reserved

Bits 1-0 Power State (PWS)

This two bit field determines the current power state for the function and is used to set the function to a new power state. The definitions of the field values are:

00b - D0

01b - Reserved

10b - Reserved

11b - D3hot

Register 46h

PMCSR BSE

Read Only

BSE	BSE	BSE	BSE	BSE	BSE	BSE	BSE
7	6	5	4	3	2	1	0
Default >>>							
0	0	0	0	0	0	0	0

This register can support PCI bridge specific functionality if required. The default value always returns 00h.

Register 47h

Data

Read Only

This register provides an optional mechanism for the function to report state-dependent operating data. The default value is 00h. This is currently not implemented for these devices.

Chapter 5, Operating Registers

On page 5-12, the formula given to calculate the synchronous send and receive rates is incorrect.

The correct formula is:

$$\text{Synchronous Send Rate} = (\text{SCLK}/\text{SCF})/\text{XFERP}$$

$$\text{Synchronous Receive Rate} = (\text{SCLK}/\text{SCF})/4$$

Key:

SCLK = SCSI Clock

SCF = Synchronous Clock Conversion Factor, SCNTL3 bits 6-4

XFERP = Transfer period, SXFER register bits 7-5