



APPLICATIONS

- Direct Attached SAS/SATA controller solutions for entry to mid-range servers
- Blade Servers
- External storage controllers requiring SAS/SATA interface for the host or drive side connect

FEATURES

- Integrated RAID – RAID Levels 0, 1, 1E, and 10
 - Integrated MegaRAID® support available upon request
- High Performance IOP
 - PowerPC 440 @ 800MHz
- 6Gb/s SAS Interface
 - 8 port SAS/SATA controller
 - Supports 1.5Gb/s, 3Gb/s, and 6Gb/s SAS and SATA data transfer rates
 - Spread spectrum clocking
 - Supports SSP, SMP, STP and SATA protocols
 - SAS and SATA device support
 - Supports narrow and wide ports
 - T-10 data protection model
 - Optical Support and Advanced Error Reporting (AER)
 - PCI Express hot plug support
 - Supports up to 1,000 devices
- PCI Express 3.0 Interface
 - Supports x8, x4, x1 PCIe lanes at a transfer rate up to 8.0 GT/s per lane, full duplex
 - Lane and polarity reversal
 - SR-IOV (16 virtual functions)
 - Supports End-to-End CRC (ECRC) and Advanced Error Reporting (AER)
 - PCI Express hot plug support

LSISAS2308

PCI Express to 8-Port 6Gb/s SAS/SATA Controller

Extending Its RAID And SAS Technology Leadership, LSI™ Introduces Its Third Generation Of SAS/SATA Controllers

LSI offers the broadest SAS product portfolio in the industry with true end-to-end solutions — controllers, expanders, SAS to SATA bridge products, ROCs, host bus adapters, RAID solutions, and external storage. LSI's proven SAS core has completed extensive stress and interoperability testing resulting in the industry's most robust, interoperable solution.

Overview

The LSISAS2308 is the third generation of SAS controllers based on the industry-leading Fusion-MPT™ (Message Passing Technology) architecture. The LSISAS2308 integrates the latest enhancements in SAS and PCI Express technology.

The LSISAS2308 supports 8 PCIe lanes and complies with the PCI Express 3.0 specification that extends the PCIe data rates up to 8.0 GT/s per lane, and is backwards compatible to the 5.0/2.5 GT/s data rate supported by PCIe 2.x., 1.x. It also incorporates enhancements such as Single Root I/O Virtualization (SR-IOV) with 16 virtual functions, End-to-End CRC (ECRC) with Advanced Error Reporting (AER) and the latest advancements in lane and polarity reversal, power management, hot plug support, and MSI/ MSI-X and legacy interrupt generation.

The eight-port controller device provides SAS and SATA data transfer rates of 1.5, 3, and 6Gb/s per lane and automatically negotiates between the speeds. Enhanced features are

supported such as T-10 Data Protection Model for early detection of and recovery from data corruption, and Spread Spectrum Clocking (SSC) for EMI reduction.

The LSISAS2308 is ideal for the host or drive side connect for external storage controllers requiring a SAS/SATA interface. The LSISAS2308 can support 1,000 devices and 10,000 outstanding IOs without external RAM and can achieve 600,000 IOs per second.

The LSISAS2308 offered with LSI's Integrated RAID (IR) feature is a low cost, high performance RAID solution designed for blade, entry and mid-range servers that require redundancy and high availability but where a full

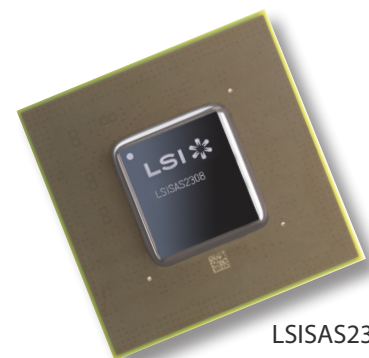

LSISAS2308

featured RAID implementation is cost prohibitive or not desired. LSI's advanced Integrated RAID options include Integrated Mirroring (IM), which is RAID 1, Integrated Mirroring Enhanced (IME), known as RAID 1E, Integrated Striping (IS), which is RAID 0, and Integrated Mirroring and Striping (IMS) which is RAID 10. By simplifying the RAID configuration options, Integrated RAID is easy to install and configure and meets the needs of most internal RAID requirements.

LSI provides a complete suite of industry while reducing time to market, integration, standard operating system drivers. LSI also supports Virtual Operating Systems with device emulation and

para-virtualization in support of the emerging SR-IOV technology.

Fusion-MPT Architecture Overview

Fusion-MPT architecture marks the next generation of I/O architecture designed to deliver the highest performance available today while reducing time to market, integration, and certification time. Fusion-MPT devices are high performance, cost-effective protocol controllers that represent the newest system-level integration technology in intelligent I/O processors from LSI.

Please contact your LSI Sales Representative for ordering information.

FEATURES (Continued)

- Advanced Power Management support
 - Slumber and Partial power mode support for SAS and SATA devices
 - Programmable SAS link power down
 - Variable PCIe bandwidth negotiation
- External memory interface support
 - Flash ROM
 - NVSRAM for Integrated Mirroring
- Communication Interfaces
 - I2C interfaces for enclosure management services
 - UART and Ethernet interface for debug
- SFF-8485 Compliant, SGPIO
- JTAG support
- 837 FPBGA-HP (25mm)

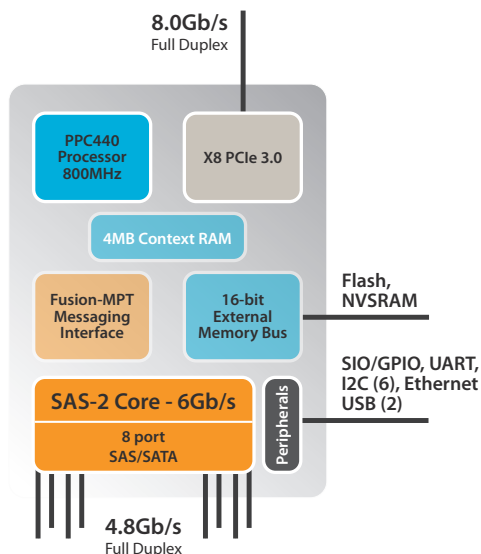

Figure 1: LSI SAS2308 Block Diagram

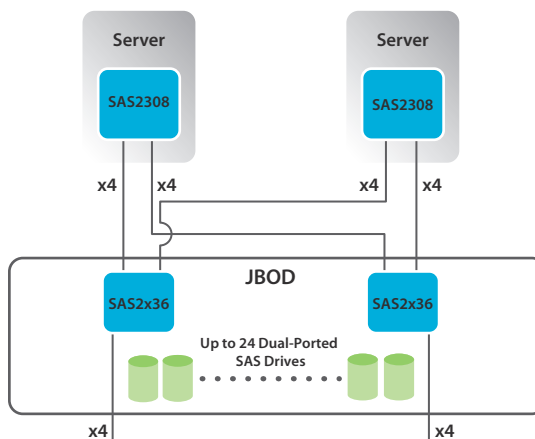

Figure 2: LSI SAS2308 Topology Diagram

For more information and sales office locations, please visit the LSI web sites at: lsi.com lsi.com/contacts
 Phone: 1.866.574.5741 or 1.610.712.4323

LSI, LSI Design logo, Fusion-MPT, MegaRAID and MegaRAID Software Manager (MSM) are trademarks or registered trademarks of LSI Corporation. All other brand and product names may be trademarks of their respective companies.

LSI Corporation reserves the right to make changes to any products and services herein at any time without notice. LSI does not assume any responsibility or liability arising out of the application or use of any product or service described herein, except as expressly agreed to in writing by LSI; nor does the purchase, lease, or use of a product or service from LSI convey a license under any patent rights, copyrights, trademark rights, or any other of the intellectual property rights of LSI or of third parties.

Copyright ©2010 by LSI Corporation. All rights reserved.
 February 2010

