

Isolation Amplifier for Voltage Sensing in Electric and Hybrid Vehicles

White Paper

Kenji Yamamoto, Andy Poh

Introduction

The introduction of electric and hybrid electric vehicles have added high voltage electric modules into the car. The battery stack in a hybrid vehicle can be in excess of 150 V, which is then boosted to a much higher voltage level for the inverter driving the electric motor. The ACPL-782T automotive isolation amplifier, which is part of Avago's R²Coupler™ series, features safe insulation, high common mode transient rejection and precision analog sensing – all in a compact 300 mil dual-in-line package.

Safe Insulation

With the high voltage and current levels present, components with excellent isolation and insulation specifications are needed, and optocouplers have been the component of choice by the automotive manufacturers for many years. As part of the R²Coupler family, the ACPL-782T targets demanding, long-life automotive applications. R²Coupler devices feature a thick triple insulation layer construction that forms the basis of their reinforced insulation rating. With 891 V_{peak} working voltage and 6000 V_{peak} transient over-voltage specifications, the ACPL-782T can meet the insulation requirements of most automotive applications.

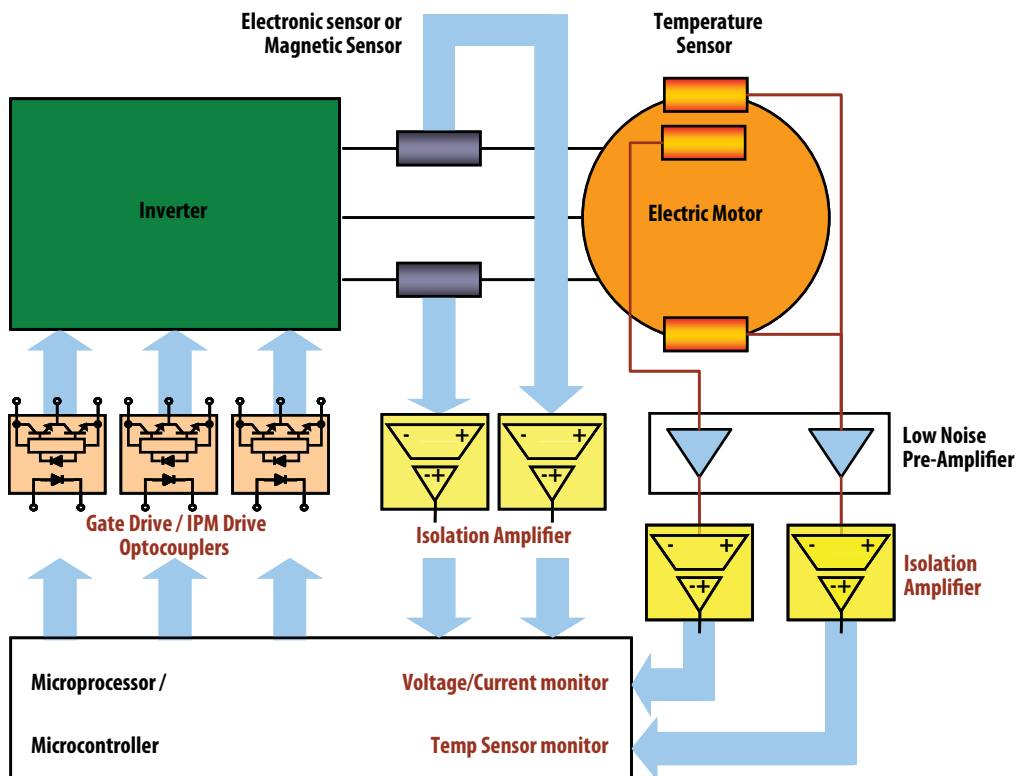

Figure 1. HEV Electric Motor Drive System

Analog Signal Isolation

The high current switching of the inverter that powers the vehicle motor generates high speed, high voltage transients throughout the electrical system. This poses a tough challenge to the processor monitoring the rail voltage and to the many analog sensors that operate in an environment with high noise levels, large common mode voltages and ground loop currents.

The ACPL-782T uses a Σ - Δ architecture where the differential analog input is converted into digital pulses that are transmitted optically across the insulation barrier. The input-output capacitance, C_{I-O} , of the ACPL-782T is extremely low and gives the amplifier excellent common mode transient rejection, ensuring that all the optically isolated digital pulses are transmitted without missing bits. The optical signals are received by the photo-detector, decoded and converted to a differential analog output.

System Accuracy Considerations

The input voltage range of the ACPL-782T is ± 200 mV. For the full battery stack or the inverter rail voltage, which can be in excess of 200 V, the resistor divider network formed by R_A and R_B and shown in Figure 2 will step down the rail voltage by more than 1000 times to match the input voltage range of the ACPL-782T.

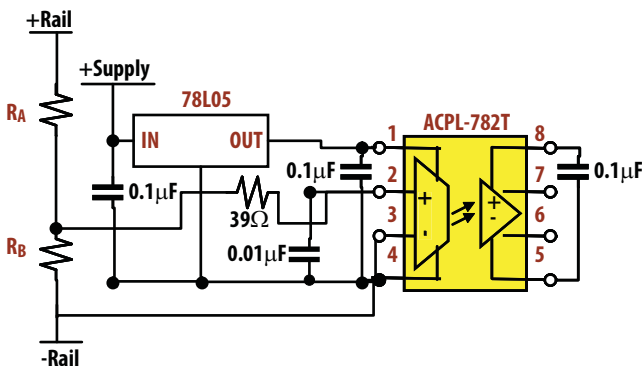

Figure 2. Stepping down the high rail voltage to match the ACPL-782T input voltage range

In this case where the resistor value of R_A is much larger than the resistor value of R_B , the precision of the resistors used and not their values will significantly affect the accuracy. The plot in Figure 3 shows that the divider error is approximately 1% (where $R_A / (R_A + R_B)$ is 0.999) with 0.5% accurate resistors.

The ACPL-782T features a low gain-error of 2% and an input offset voltage of 1% of full scale input. If more accuracy is needed these errors can be easily reduced or removed with calibration.

The low gain-drift, offset drift and nonlinearity error across the automotive grade 1 temperature range is typically less than 1% and will be seen in the system since it cannot be removed by calibration.

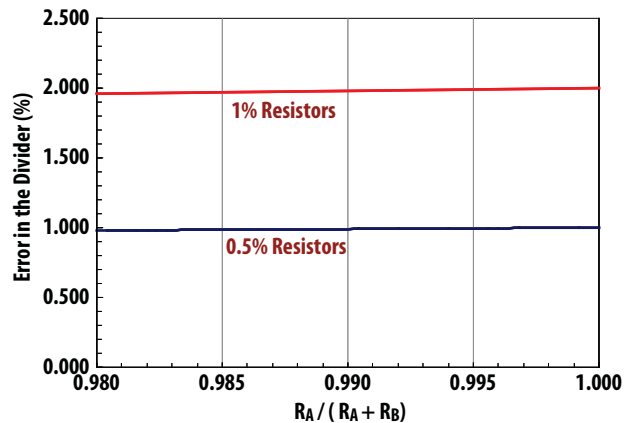

Figure 3. Divider error with 0.5% and 1% resistors

The ACPL-782T's Σ - Δ architecture shapes and moves the noise profile to higher frequencies far beyond the desired operating bandwidth. This architecture has a trade-off between bandwidth and signal-to-noise ratio (SNR) performance; high frequency noise and transients can be easily filtered and there is still sufficient bandwidth for the much lower frequency analog signals.

In the remote voltage sensing amplifier circuit shown in Figure 4, the 10 k Ω resistor and 150 pF capacitor form a first order, low pass output filter that reduces the high frequency noise coming out of the ACPL-782T. This filter can be adjusted to suit the application's desired bandwidth.

Table 1 shows ACPL-782T performance as a function of analog filter bandwidth. Where the filter bandwidth is narrow the SNR improves.

Table 1. ACPL-782T signal-to-noise performance vs. bandwidth

Bandwidth (1 st Order Analog Filter)	Output Referred Noise	Input Referred Noise	Signal-to-Noise Ratio ($V_{in}=0.2V_p$)	Resolution
kHz	mV _{RMS}	mV _{RMS}	dB	Bits
106.1	5.3	0.7	46.5	7.4
63.7	3.9	0.5	49.2	7.9
43.0	3.2	0.4	51.1	8.2
33.2	1.0	0.1	60.8	9.8
13.8	0.7	0.1	64.2	10.4

Other Inverter System Considerations

In practical terms, the microprocessor tends to be in a shielded module well away from the motor. The input voltage range of the ACPL-782T is small and to reduce noise introduced into the input of the amplifier it is preferable to locate the automotive isolation amplifier close to the voltage rail to be monitored. The ACPL-782T has a fixed gain of eight; therefore noise entering the output side will have less effect than noise, of similar amplitude, entering from the input side.

The differential output configuration of the ACPL-782T facilitates transmission of the isolated sensed voltage over twisted-pair cables to the processor. The output can then be terminated into a high impedance and through a first order analog filter to provide very accurate readings at the processor. The circuit shown in Figure 4 shows a typical circuit that implements these concepts.

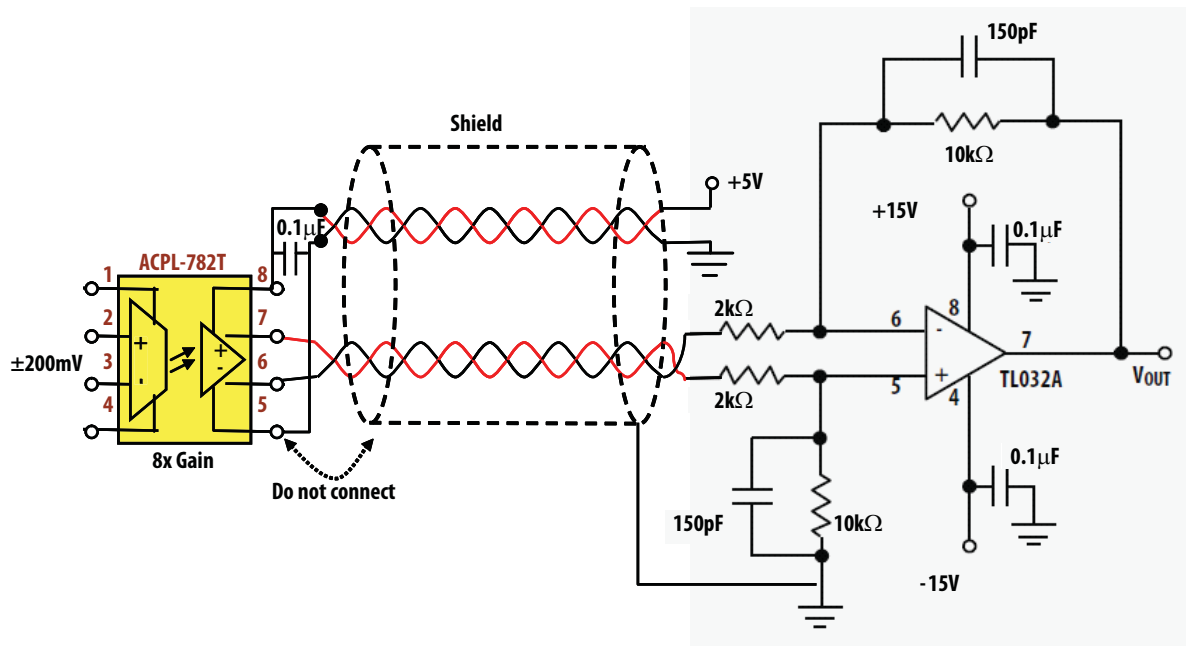

Figure 4. ACPL-782T remote voltage sensing circuit with analog filter

Battery Cell Voltage Sensing

Besides voltage sensing in the inverter module, many voltage sensing nodes are also found in battery cells. From NiMH battery systems with battery stacks of about 13 V to the individual Li-Ion battery cell voltage of about 3.6 V, all can rely on the ACPL-782T for protection as well as level shifting. The monitoring of the full battery stack voltage and output voltage to the boost converter will have a similar step down range as from the inverter.

Conclusion

Because of Avago's R²Coupler technology, the ACPL-782T features reinforced insulation and increased reliability. The low input-output coupling capacitance of the optically-isolated amplifier features extremely high common mode transient immunity and improved system robustness. With the high accuracy provided by the Σ - Δ architecture, the ACPL-782T is suitable for many voltage-sensing automotive applications, and there is a good balance between bandwidth and signal-to-noise ratio.

For product information and a complete list of distributors, please go to our web site: www.avagotech.com

Avago, Avago Technologies, the A logo, R²Coupler are trademarks of Avago Technologies in the United States and other countries. Data subject to change. Copyright © 2005-2010 Avago Technologies. All rights reserved. AV02-1790EN - March 25, 2010

AVAGO
TECHNOLOGIES